

版本變更履歷

Version Change History

版本 Rev.	變更前 Before Change	變更後 After Change	更改日期 Change Date	批准 Approved By
A.0	新发行	----	2023/08/04	钱立谋

SPECIFICATION

產品型號: DESC	$\Phi 20.5 \times 41-10Ts-0.08 \times 105-15mm-CLB$	版本 Rev: A 0	客戶 CUST: 淘软料号 Fine P/N: 客户料号 CUST P/N:	
---------------	---	----------------	--	--

一、尺寸 DIMENSION:(mm)

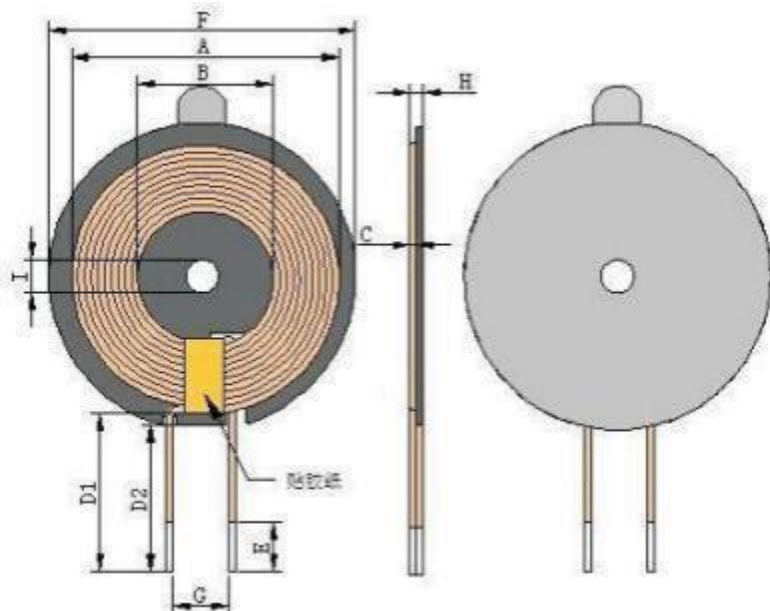

A	41.0 ± 1
B	20.5 ± 0.5
C	1.0 ± 0.1
D1	17 ± 2
D2	15 ± 2
E	3-5mm
F	50 ± 0.5
G	11.0 ref
H	4.8 ± 0.2 Max
I	5.3 ref

注:

1. Coil attached magnetic disc, magnetic disc size 50±0.5mm, inner hole 5.3mm, thickness 1.0±/- 0.1mm, double slot
2. Wrap high temperature adhesive paper with a width of 8mm ±0.5 at the coil outlet position.
3. The back of the magnetic disc is affixed with hand-torn circular diameter 48mm(ref), the inner hole is 7.0mm (ref) and the thickness is 2.5mm EVA foam.

二、原理图 SCHEMATIC DIAGRAM:

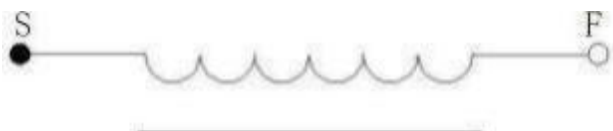

三、绕线参数 Winding Specification:

序号 NO	端子 TERMINAL	线径 WIRE	圈数 Turns	绕线方向 Winding Direction
1	S F	Silk-covered wire 0.08*105P	10Ts	CCW

四、电气特性 ELECTRICAL CHARACTERISTICS:

温度 TEMPERATURE :25 ±10 °C, 湿度 RELATIVE HUMIDITY :65 ±20%

序号 NO	项目 ITEM	端子 TERMINAL	标准 SPECIFICATION	测试条件 TEST FREQUENCY	测试仪器 TEST EQUIPMENTS
1	IND.	S-F	3.8uH ±20% Individual coil	100KHz/1.0V	LCZ METER 1062B
2	IND.	S-F	6.5 uH ±10% Magnetized sheet	100KHz/1.0V	LCZ METER 1062B
3	Q 值	S-F	≤60(ref) Magnetized sheet	100KHz/1.0V	LCZ METER 1062B
4	DCR	S-F	≤70m Ω		LCZ METER 502B

拟制/日期 PREPARED BY/DATE

审核/日期 CHECKED BY/DATE

Boqun Feng 2023/08/04

Yanping Su 2023/08/04

EUT Photo

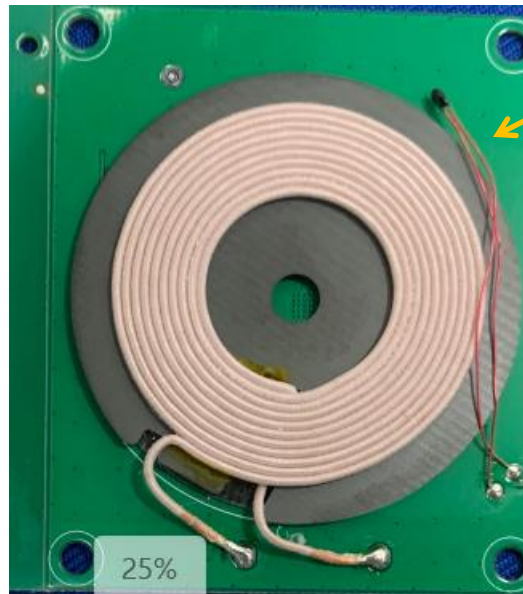

Coil Antenna