



RF TEST REPORT

Applicant ZTE Corporation
FCC ID SRQ-A31PLUS3
Product LTE/WCDMA/GSM(GPRS)
Multi-Mode Digital Mobile Phone
Model ZTE Blade A31 Plus
Report No. R2205A0440-R8
Issue Date June 14, 2022

TA Technology (Shanghai) Co., Ltd. tested the above equipment in accordance with the requirements in **FCC CFR47 Part 2 (2021)/ FCC CFR 47 Part 22H (2021)**. The test results show that the equipment tested is capable of demonstrating compliance with the requirements as documented in this report.

Prepared by: Peng Tao

Approved by: Kai Xu

TA Technology (Shanghai) Co., Ltd.

No.145, Jintang Rd, Tangzhen Industry Park, Pudong Shanghai, China

TEL: +86-021-50791141/2/3

FAX: +86-021-50791141/2/3-8000



TABLE OF CONTENT

1. Test Laboratory	4
1.1. Notes of the Test Report	4
1.2. Test facility	4
1.3. Testing Location	4
2. General Description of Equipment under Test.....	5
2.1. Applicant and Manufacturer Information	5
2.2. General Information.....	5
3. Applied Standards.....	7
4. Test Configuration.....	8
5. Test Case.....	9
5.1. RF Power Output and Effective Radiated Power	9
5.2. Occupied Bandwidth	10
5.3. Band Edge Compliance.....	11
5.4. Peak-to-Average Power Ratio (PAPR)	12
5.5. Frequency Stability.....	13
5.6. Spurious Emissions at Antenna Terminals	15
5.7. Radiates Spurious Emission	16
6. Test Result	19
6.1. RF Power Output and Effective Radiated Power	19
6.2. Occupied Bandwidth	27
6.3. Band Edge Compliance.....	37
6.4. Peak-to-Average Power Ratio (PAPR)	47
6.5. Frequency Stability.....	49
6.6. Spurious Emissions at Antenna Terminals	51
6.7. Radiates Spurious Emission	54
7. Main Test Instruments	56
ANNEX A: The EUT Appearance.....	57
ANNEX B: Test Setup Photos	58



Summary of measurement results

No.	Test Case	Clause in FCC rules	Verdict
1	RF Power Output and Effective Radiated Power	2.1046 22.913(a)(5)	PASS
2	Occupied Bandwidth	2.1049	PASS
3	Band Edge Compliance	2.1051 / 22.917(a)	PASS
4	Peak-to-Average Power Ratio	22.913(d)/ KDB 971168 D01(5.7)	PASS
5	Frequency Stability	2.1055 / 22.355	PASS
6	Spurious Emissions at Antenna Terminals	2.1051 / 22.917(a)	PASS
7	Radiates Spurious Emission	2.1053 / 22.917 (a)	PASS

Date of Testing: May 30, 2022 ~ June 7, 2022

Date of Sample Received: May 24, 2022

Note: PASS: The EUT complies with the essential requirements in the standard.

FAIL: The EUT does not comply with the essential requirements in the standard.

All indications of Pass/Fail in this report are opinions expressed by TA Technology (Shanghai) Co., Ltd. based on interpretations and/or observations of test results. Measurement Uncertainties were not taken into account and are published for informational purposes only.



1. Test Laboratory

1.1. Notes of the Test Report

This report shall not be reproduced in full or partial, without the written approval of **TA technology (shanghai) co., Ltd.** The results documented in this report apply only to the tested sample, under the conditions and modes of operation as described herein. Measurement Uncertainties were not taken into account and are published for informational purposes only. This report is written to support regulatory compliance of the applicable standards stated above.

1.2. Test facility

FCC (Designation number: CN1179, Test Firm Registration Number: 446626)

TA Technology (Shanghai) Co., Ltd. has been listed on the US Federal Communications Commission list of test facilities recognized to perform measurements.

A2LA (Certificate Number: 3857.01)

TA Technology (Shanghai) Co., Ltd. has been listed by American Association for Laboratory Accreditation to perform measurement.

1.3. Testing Location

Company: TA Technology (Shanghai) Co., Ltd.
Address: No.145, Jintang Rd, Tangzhen Industry Park, Pudong
City: Shanghai
Post code: 201201
Country: P. R. China
Contact: Xu Kai
Telephone: +86-021-50791141/2/3
Fax: +86-021-50791141/2/3-8000
Website: <http://www.ta-shanghai.com>
E-mail: xukai@ta-shanghai.com

2. General Description of Equipment under Test

2.1. Applicant and Manufacturer Information

Applicant	ZTE Corporation
Applicant address	ZTE Plaza, #55 Keji Road South, Hi-Tech Industrial Park, Nanshan District, Shenzhen, China
Manufacturer	ZTE Corporation
Manufacturer address	ZTE Plaza, #55 Keji Road South, Hi-Tech Industrial Park, Nanshan District, Shenzhen, China

2.2. General Information

EUT Description			
Model	ZTE Blade A31 Plus		
IMEI	865588060001219		
Hardware Version	z1kA		
Software Version	4.0.0_A31Plus_TEL		
Power Supply	Battery / AC adapter		
Antenna Type	Internal Antenna		
Antenna Gain	-4.2dBi		
Test Mode(s)	LTE Band 26;		
Test Modulation	(LTE) QPSK, 16QAM, 64QAM;		
LTE Category	5		
Maximum E.R.P.	16.32dBm		
Rated Power Supply Voltage	3.8V		
Operating Voltage	Minimum: 3.40V Maximum: 4.35V		
Operating Temperature	Lowest: -10°C Highest: +55°C		
Testing Temperature	Lowest: -30°C Highest: +50°C		
Operating Frequency Range(s)	Band	Tx (MHz)	Rx (MHz)
	LTE Band 26	824 ~ 849	869 ~ 894
EUT Accessory			
Adapter 1	Manufacturer: Shenzhen Ruijing Industrial Co.,Ltd Model: STC-A51D-Z		
Adapter 2	Manufacturer: HUIZHOU PUAN ELECTRONICS CO.,LTD Model: STC-A51D-Z		
Battery	Manufacturer: Guangdong Fenghua New Energy Co.,Ltd. Model: Li3830T43P8h486375		
Earphone 1	Manufacturer: Shenzhen FDC Electronics Co. ,Ltd. Model: DEM-8A		
Earphone 2	Manufacturer: JUWEI ELECTRONICS CO., LTD Model: JWEP1091-Z01		



USB Cable 1	Manufacturer: Dongguan Guojun Plastic Electronic Co.,Ltd Model: USB-MU5-B-70-M-L
USB Cable 2	Manufacturer: Shenzhen Yihuaxing Electronic Co., Ltd. Model: USB-MU5-B-70-M-L
<p>Note: 1. The EUT is sent from the applicant to TA and the information of the EUT is declared by the applicant.</p> <p>2. There are more than one Adapter, Earphone and USB Cable, each one should be applied throughout the compliance test respectively, however, only the worst case (Adapter 1, Earphone 2 and USB Cable 1) will be recorded in this report.</p>	



3. Applied Standards

According to the specifications of the manufacturer, it must comply with the requirements of the following standards:

Test standards:

FCC CFR 47 Part 22H (2021)

FCC CFR47 Part 2-2021

Reference standard:

ANSI C63.26 (2015)

KDB 971168 D01 Power Meas License Digital Systems v03r01

4. Test Configuration

There is more than one SIM card slot, each one should be applied throughout the compliance test respectively, and however, only the worst case (SIM 1) will be recorded in this report.

Radiated measurements are performed by rotating the EUT in three different orthogonal test planes. EUT stand-up position (Z axis), lie-down position (X, Y axis). Receiver antenna polarization (horizontal and vertical), the worst emission was found in position (Z axis, horizontal polarization) and the worst case was recorded.

All mode and data rates and positions and RB size and modulations were investigated. Subsequently, only the worst case emissions are reported.

The following testing in LTE is set based on the maximum RF Output Power.

Test modes are chosen as the worst case configuration below for LTE Band 26

Test items	Modes	Bandwidth (MHz)					Modulation		RB			Test Channel		
		1.4	3	5	10	15	QPSK	16QAM/64QAM	1	50%	100%	L	M	H
RF power output and Effective Radiated power	LTE 26	O	O	O	O	O	O	O	O	O	O	O	O	O
Occupied Bandwidth	LTE 26	O	O	O	O	O	O	O	-	-	O	O	O	O
Band Edge Compliance	LTE 26	O	O	O	O	O	O	O	O	-	O	O	-	O
Peak-to-Average Power Ratio	LTE 26	O	O	O	O	O	O	O	-	-	O	O	O	O
Frequency Stability	LTE 26	O	O	O	O	O	O	O	O	-	-	-	O	-
Spurious Emissions at Antenna Terminals	LTE 26	O	O	O	O	O	O	-	O	-	-	O	O	O
Radiates Spurious Emission	LTE 26	O	-	O	-	O	O	-	O	-	-	-	O	-
Note	1. The mark "O" means that this configuration is chosen for testing. 2. The mark "-" means that this configuration is not testing.													

5. Test Case

5.1. RF Power Output and Effective Radiated Power

Ambient condition

Temperature	Relative humidity	Pressure
23°C ~25°C	45%~50%	101.5kPa

Methods of Measurement

During the process of the testing, The EUT was connected to the Base Station Simulator with a known loss. The EUT is controlled by the Base Station Simulator test set to ensure max power transmission with proper modulation.

ERP can then be calculated as follows:

$$\text{EIRP (dBm)} = \text{Output Power (dBm)} - \text{Losses (dB)} + \text{Antenna Gain (dBi)}$$

where:dBd refers to gain relative to an ideal dipole.

$$\text{EIRP (dBm)} = \text{ERP (dBm)} + 2.15 \text{ (dB)}.$$

Test Setup

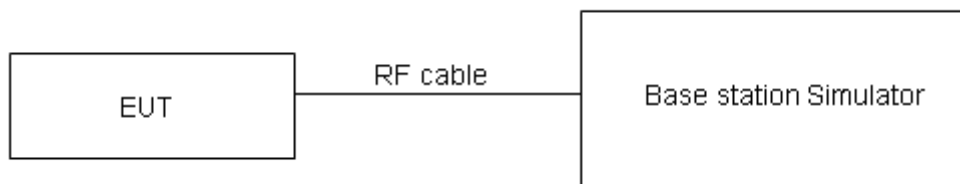

Limits

No specific RF power output requirements in part 2.1046.

Rule Part 22.913(a)(5) specifies that "Mobile/portable stations are limited to 7 watts ERP".

Limit	$\leq 7 \text{ W}$ (38.45 dBm)
-------	--------------------------------

Measurement Uncertainty

The assessed measurement uncertainty to ensure 95% confidence level for the normal distribution is with the coverage factor $k = 2$, $U = 0.4 \text{ dB}$ for RF power output, $k = 2$, $U = 1.19 \text{ dB}$ for ERP.

Test Results

Refer to the section 6.1 of this report for test data.

5.2. Occupied Bandwidth

Ambient condition

Temperature	Relative humidity	Pressure
23°C ~25°C	45%~50%	101.5kPa

Method of Measurement

The EUT was connected to Spectrum Analyzer and Base Station Simulator via power Splitter. The occupied bandwidth is measured using spectrum analyzer.

RBW is set to $\geq 1\%EBW$, VBW is set to 3x RBW.

99% power and -26dBc occupied bandwidths are recorded. Spectrum analyzer plots are included on the following pages.

Test Setup

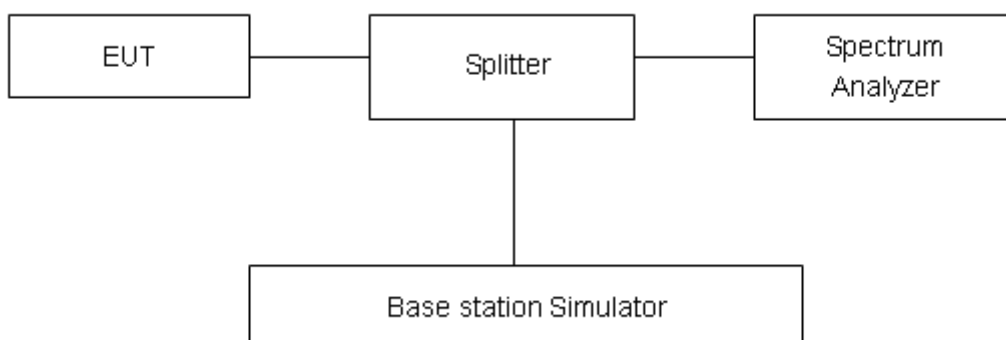

Limits

No specific occupied bandwidth requirements in part 2.1049.

Measurement Uncertainty

The assessed measurement uncertainty to ensure 95% confidence level for the normal distribution is with the coverage factor $k = 2$, $U = 624\text{Hz}$.

Test Results

Refer to the section 6.2 of this report for test data.

5.3. Band Edge Compliance

Ambient condition

Temperature	Relative humidity	Pressure
23°C ~25°C	45%~50%	101.5kPa

Method of Measurement

The EUT was connected to Spectrum Analyzer and Base Station Simulator via power Splitter. The band edge of the lowest and highest channels were measured. The average detector is used. RBW is set to $\geq 1\%EBW$, VBW is set to 3x RBW.

Spectrum analyzer plots are included on the following pages.

Test Setup

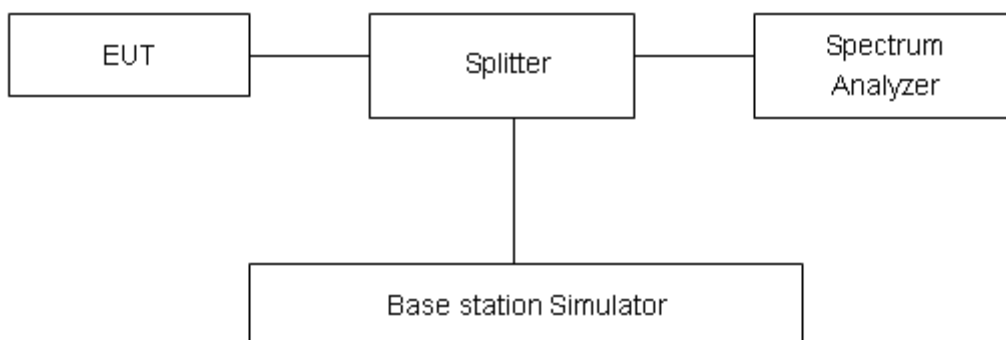

Limits

Rule Part 22.917(a) specifies that “The power of any emission outside of the authorized operating frequency ranges must be attenuated below the transmitting power (P) by a factor of at least $43 + 10 \log(P)$ dB.”

Limit	-13 dBm
-------	---------

Measurement Uncertainty

The assessed measurement uncertainty to ensure 95% confidence level for the normal distribution is with the coverage factor $k = 1.96$, $U=0.684$ dB.

Test Results

Refer to the section 6.3 of this report for test data.

5.4. Peak-to-Average Power Ratio (PAPR)

Ambient condition

Temperature	Relative humidity	Pressure
23°C ~25°C	45%~50%	101.5kPa

Methods of Measurement

Measure the total peak power and record as P_{Pk} . And measure the total average power and record as P_{Avg} . Both the peak and average power levels must be expressed in the same logarithmic units (e.g., dBm). Determine the PAPR from:

$$PAPR (dB) = P_{Pk} (dBm) - P_{Avg} (dBm).$$

Test Setup

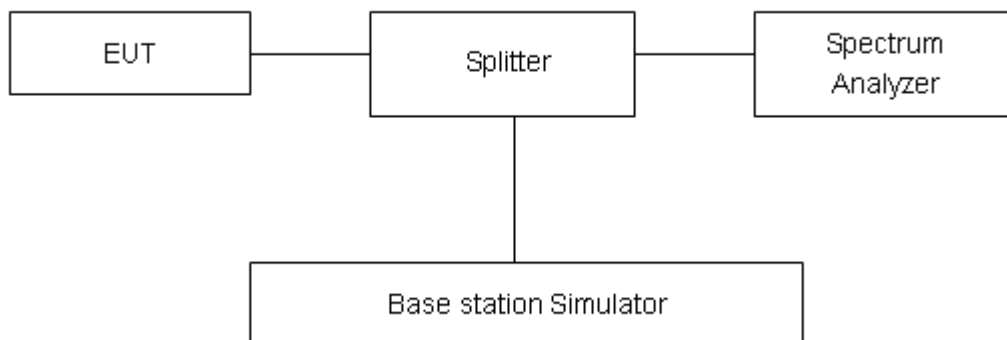

Limits

According to the Sec. 22.913(d), The peak-to-average ratio (PAR) of the transmission must not exceed 13 dB.

Measurement Uncertainty

The assessed measurement uncertainty to ensure 95% confidence level for the normal distribution is with the coverage factor $k = 2$, $U = 0.4$ dB.

Test Results

Refer to the section 6.4 of this report for test data.

5.5. Frequency Stability

Ambient condition

Temperature	Relative humidity	Pressure
23°C ~25°C	45%~50%	101.5kPa

Method of Measurement

Frequency Stability (Temperature Variation)

The temperature inside the climate chamber is varied from -30°C to +50°C in 10°C step size,

(1) With all power removed, the temperature was decreased to 0°C and permitted to stabilize for three hours.

(2) Measure the carrier frequency with the test equipment in a “call mode”. These measurements should be made within 1 minute of powering up the mobile station, to prevent significant self warming.

(3) Repeat the above measurements at 10°C increments from -30°C to +50°C. Allow at least 1.5 hours at each temperature, un-powered, before making measurements. Frequency Stability (Voltage Variation)

The frequency stability shall be measured with variation of primary supply voltage as follows:

Primary Supply Voltage: The primary supply voltage is varied from 85% to 115% of the nominal value for non hand-carried battery and AC powered equipment. For hand-carried, battery-powered equipment, primary supply voltage is reduced to the battery operating end point which shall be specified by the manufacturer.

This transceiver is specified to operate with an input voltage of between 3.4 V and 4.35 V, with a nominal voltage of 3.8V.

Test setup

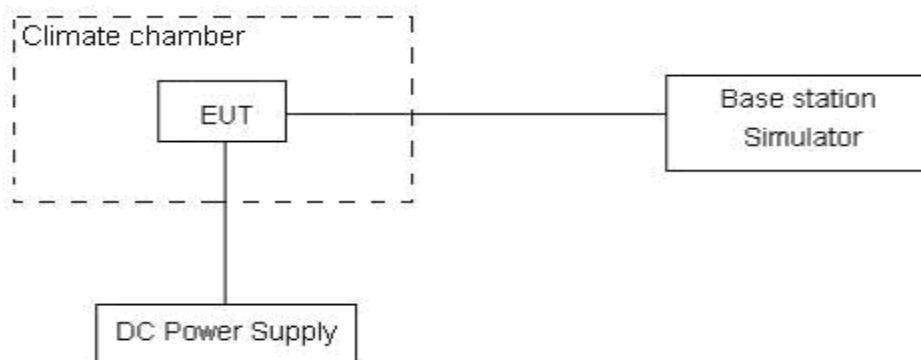

Limits

According to the Sec. 22.355, the frequency stability of the carrier shall be accurate to within 2.5 ppm of the received frequency for mobile stations.

Limits	≤ 2.5 ppm
--------	-----------

Measurement Uncertainty

The assessed measurement uncertainty to ensure 99.75% confidence level for the normal distribution is with the coverage factor $k = 3$, $U = 0.01\text{ppm}$.



Test Results

Refer to the section 6.5 of this report for test data.

5.6. Spurious Emissions at Antenna Terminals

Ambient condition

Temperature	Relative humidity	Pressure
23°C ~25°C	45%~50%	101.5kPa

Method of Measurement

The EUT was connected to Spectrum Analyzer and Base Station Simulator via power Splitter. The measurement is carried out using a spectrum analyzer. The spectrum analyzer scans from 9kHz to the 10th harmonic of the carrier.

The peak detector is used. RBW are set to 100 kHz and VBW are set to 300 kHz for below 1G, RBW are set to 1MHz and VBW are set to 3MHz for above 1G, Sweep is set to ATUO.

RBW is set to 1 kHz (0.009MHz~ 0.15 MHz),

RBW is set to 10 kHz (0.15 MHz~ 30 MHz)

RBW is set to 100 kHz (30MHz~1000 MHz)

RBW is set to 1000 kHz (above 1000MHz)

The modulation mode and RB allocation refer to section 5.1, using the maximum output power configuration.

Test setup

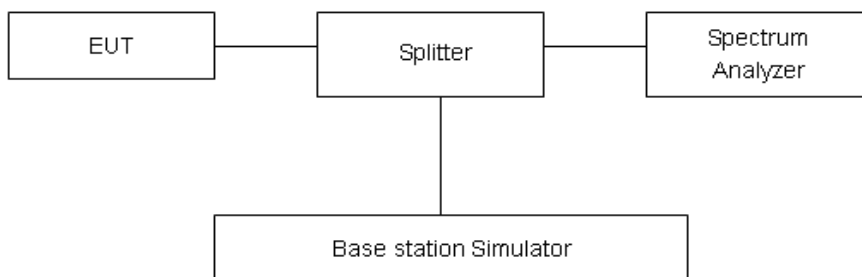

Limits

Rule Part 22.917(a) specifies that “The power of any emission outside of the authorized operating frequency ranges must be attenuated below the transmitting power (P) by a factor of at least 43 + 10 log (P) dB.”

Limit	-13 dBm
-------	---------

Measurement Uncertainty

The assessed measurement uncertainty to ensure 99.75% confidence level for the normal distribution is with the coverage factor $k = 1.96$.

Frequency	Uncertainty
9kHz-1GHz	0.684 dB
1GHz-18GHz	1.407 dB

Test Results

Refer to the section 6.6 of this report for test data.

5.7. Radiates Spurious Emission

Ambient condition

Temperature	Relative humidity	Pressure
23°C ~25°C	45%~50%	101.5kPa

Method of Measurement

1. The testing follows FCC KDB 971168 v03r01 Section 5.8 and ANSI C63.26 (2015).
2. Below 1GHz: The EUT is placed on a turntable 0.8 meters above the ground in the chamber, 3 meter away from the antenna. The maximal emission value is acquired by adjusting the antenna height, polarisation and turntable azimuth. Normally, the height range of antenna is 1 m to 4 m, the azimuth range of turntable is 0° to 360°, and the receive antenna has two polarizations Vertical (V) and Horizontal (H). Above 1GHz: (Note: the FCC's permission to use 1.5m as an alternative per TCBC Conf call of Dec. 2, 2014.) The EUT is placed on a turntable 1.5 meters above the ground in the chamber, 3 meter away from the antenna. The maximal emission value is acquired by adjusting the antenna height, polarisation and turntable azimuth. Normally, the height range of antenna is 1 m to 4 m, the azimuth range of turntable is 0° to 360°, and the receive antenna has two polarizations Vertical (V) and Horizontal (H).
3. A loop antenna, A log-periodic antenna or horn antenna shall be substituted in place of the EUT. The log-periodic antenna will be driven by a signal generator and the level will be adjusted till the same power value on the spectrum analyzer or receiver. The level of the spurious emissions can be calculated through the level of the signal generator, cable loss, the gain of the substitution antenna and the reading of the spectrum analyzer or receiver.
4. The EUT is then put into continuously transmitting mode at its maximum power level during the test. Set Test Receiver or Spectrum RBW=100kHz,VBW=300kHz, and the maximum value of the receiver should be recorded as (Pr).
5. The EUT shall be replaced by a substitution antenna. In the chamber, an substitution antenna for the frequency band of interest is placed at the reference point of the chamber. An RF Signal source for the frequency band of interest is connected to the substitution antenna with a cable that has been constructed to not interfere with the radiation pattern of the antenna. A power (PMea) is applied to the input of the substitution antenna, and adjust the level of the signal generator output until the value of the receiver reach the previously recorded (Pr). The power of signal source (PMea) is recorded. The test should be performed by rotating the test item and adjusting the receiving antenna polarization.
6. A amplifier should be connected to the Signal Source output port. And the cable should be connect between the Amplifier and the Substitution Antenna. The cable loss (Pcl), the Substitution Antenna Gain (Ga) and the Amplifier Gain (PAg) should be recorded after test.
7. The measurement results are obtained as described below:
Power(EIRP)=PMea- PAg - Pcl + Ga
The measurement results are amend as described below:
Power(EIRP)=PMea- Pcl + Ga
8. This value is EIRP since the measurement is calibrated using an antenna of known gain (2.15 dB) and known input power. ERP can be calculated from EIRP by subtracting the gain of the dipole, ERP

= EIRP-2.15dB.

The modulation mode and RB allocation refer to section 5.1, using the maximum output power configuration.

Test setup

9KHz ~ 30MHz

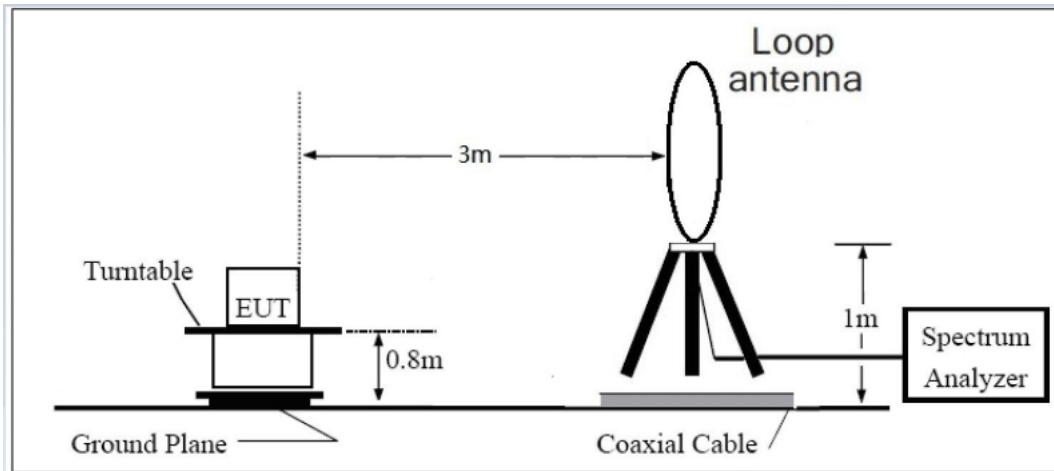

30MHz ~ 1GHz

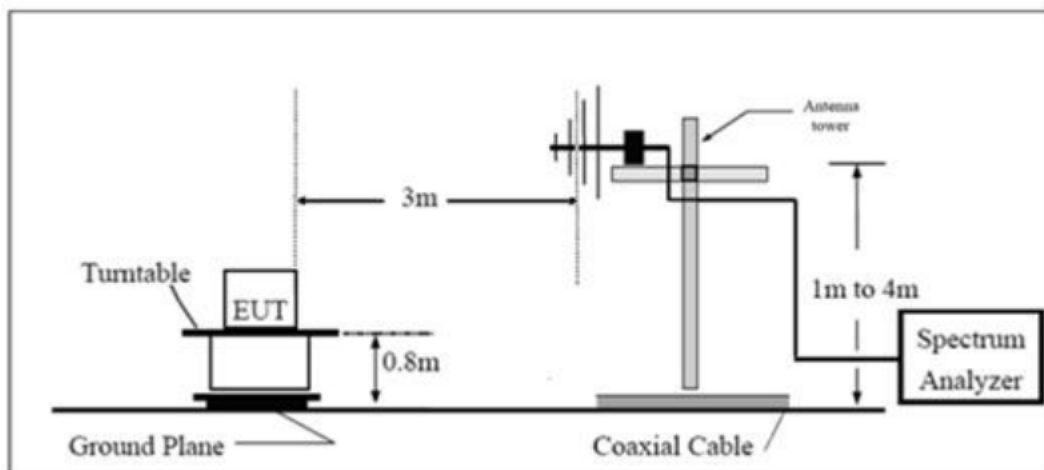

Above 1GHz

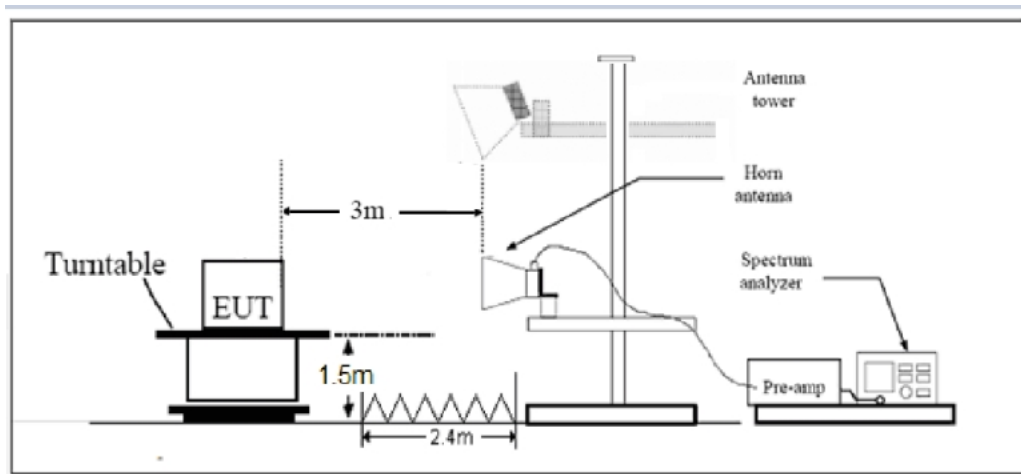

Note: Area side:2.4mX3.6m

Limits

Rule Part 22.917(a) specifies that “The power of any emission outside of the authorized operating frequency ranges must be attenuated below the transmitting power (P) by a factor of at least $43 + 10 \log (P)$ dB.”

Limit	-13 dBm
-------	---------

Measurement Uncertainty

The assessed measurement uncertainty to ensure 95% confidence level for the normal distribution is with the coverage factor $k = 1.96$, $U = 3.55$ dB.

Test Results

Refer to the section 6.7 of this report for test data.



6. Test Result

6.1. RF Power Output and Effective Radiated Power

Band	Bandwidth (MHz)	UL Channel	RB Size	RB Position	Modulation	Power (dBm)	ERP (dBm)
LTE Band26	1.4	26797	1	#0	QPSK	21.12	14.77
LTE Band26	1.4	26797	1	#Mid	QPSK	21.14	14.79
LTE Band26	1.4	26797	1	#Max	QPSK	21.08	14.73
LTE Band26	1.4	26797	3	#0	QPSK	21.00	14.65
LTE Band26	1.4	26797	3	#Mid	QPSK	20.98	14.63
LTE Band26	1.4	26797	3	#Max	QPSK	20.96	14.61
LTE Band26	1.4	26797	6	#0	QPSK	20.01	13.66
LTE Band26	1.4	26797	1	#0	QAM16	20.47	14.12
LTE Band26	1.4	26797	1	#Mid	QAM16	20.45	14.10
LTE Band26	1.4	26797	1	#Max	QAM16	20.49	14.14
LTE Band26	1.4	26797	3	#0	QAM16	20.00	13.65
LTE Band26	1.4	26797	3	#Mid	QAM16	19.99	13.64
LTE Band26	1.4	26797	3	#Max	QAM16	20.01	13.66
LTE Band26	1.4	26797	6	#0	QAM16	18.91	12.56
LTE Band26	1.4	26915	1	#0	QPSK	20.49	14.14
LTE Band26	1.4	26915	1	#Mid	QPSK	20.96	14.61
LTE Band26	1.4	26915	1	#Max	QPSK	22.47	16.12
LTE Band26	1.4	26915	3	#0	QPSK	22.52	16.17
LTE Band26	1.4	26915	3	#Mid	QPSK	22.50	16.15
LTE Band26	1.4	26915	3	#Max	QPSK	22.57	16.22
LTE Band26	1.4	26915	6	#0	QPSK	21.99	15.64
LTE Band26	1.4	26915	1	#0	QAM16	22.23	15.88
LTE Band26	1.4	26915	1	#Mid	QAM16	22.62	16.27
LTE Band26	1.4	26915	1	#Max	QAM16	22.64	16.29
LTE Band26	1.4	26915	3	#0	QAM16	21.87	15.52
LTE Band26	1.4	26915	3	#Mid	QAM16	21.86	15.51
LTE Band26	1.4	26915	3	#Max	QAM16	21.83	15.48
LTE Band26	1.4	26915	6	#0	QAM16	20.87	14.52
LTE Band26	1.4	27033	1	#0	QPSK	22.48	16.13
LTE Band26	1.4	27033	1	#Mid	QPSK	22.54	16.19
LTE Band26	1.4	27033	1	#Max	QPSK	22.54	16.19
LTE Band26	1.4	27033	3	#0	QPSK	22.50	16.15
LTE Band26	1.4	27033	3	#Mid	QPSK	22.45	16.10
LTE Band26	1.4	27033	3	#Max	QPSK	22.56	16.21
LTE Band26	1.4	27033	6	#0	QPSK	21.46	15.11
LTE Band26	1.4	27033	1	#0	QAM16	21.56	15.21



LTE Band26	1.4	27033	1	#Mid	QAM16	21.13	14.78
LTE Band26	1.4	27033	1	#Max	QAM16	21.14	14.79
LTE Band26	1.4	27033	3	#0	QAM16	21.92	15.57
LTE Band26	1.4	27033	3	#Mid	QAM16	21.94	15.59
LTE Band26	1.4	27033	3	#Max	QAM16	21.59	15.24
LTE Band26	1.4	27033	6	#0	QAM16	21.13	14.78
LTE Band26	3	26805	1	#0	QPSK	20.92	14.57
LTE Band26	3	26805	1	#Mid	QPSK	20.98	14.63
LTE Band26	3	26805	1	#Max	QPSK	20.91	14.56
LTE Band26	3	26805	8	#0	QPSK	19.96	13.61
LTE Band26	3	26805	8	#Mid	QPSK	19.96	13.61
LTE Band26	3	26805	8	#Max	QPSK	19.94	13.59
LTE Band26	3	26805	15	#0	QPSK	19.97	13.62
LTE Band26	3	26805	1	#0	QAM16	19.95	13.60
LTE Band26	3	26805	1	#Mid	QAM16	19.90	13.55
LTE Band26	3	26805	1	#Max	QAM16	19.89	13.54
LTE Band26	3	26805	8	#0	QAM16	19.00	12.65
LTE Band26	3	26805	8	#Mid	QAM16	19.01	12.66
LTE Band26	3	26805	8	#Max	QAM16	18.95	12.60
LTE Band26	3	26805	15	#0	QAM16	18.96	12.61
LTE Band26	3	26915	1	#0	QPSK	20.47	14.12
LTE Band26	3	26915	1	#Mid	QPSK	20.97	14.62
LTE Band26	3	26915	1	#Max	QPSK	21.18	14.83
LTE Band26	3	26915	8	#0	QPSK	19.40	13.05
LTE Band26	3	26915	8	#Mid	QPSK	19.41	13.06
LTE Band26	3	26915	8	#Max	QPSK	19.90	13.55
LTE Band26	3	26915	15	#0	QPSK	19.94	13.59
LTE Band26	3	26915	1	#0	QAM16	21.42	15.07
LTE Band26	3	26915	1	#Mid	QAM16	22.09	15.74
LTE Band26	3	26915	1	#Max	QAM16	22.10	15.75
LTE Band26	3	26915	8	#0	QAM16	20.49	14.14
LTE Band26	3	26915	8	#Mid	QAM16	20.49	14.14
LTE Band26	3	26915	8	#Max	QAM16	20.95	14.60
LTE Band26	3	26915	15	#0	QAM16	20.87	14.52
LTE Band26	3	27025	1	#0	QPSK	22.51	16.16
LTE Band26	3	27025	1	#Mid	QPSK	22.50	16.15
LTE Band26	3	27025	1	#Max	QPSK	22.58	16.23
LTE Band26	3	27025	8	#0	QPSK	21.97	15.62
LTE Band26	3	27025	8	#Mid	QPSK	21.98	15.63
LTE Band26	3	27025	8	#Max	QPSK	21.56	15.21
LTE Band26	3	27025	15	#0	QPSK	21.80	15.45
LTE Band26	3	27025	1	#0	QAM16	21.42	15.07
LTE Band26	3	27025	1	#Mid	QAM16	21.42	15.07



LTE Band26	3	27025	1	#Max	QAM16	21.03	14.68
LTE Band26	3	27025	8	#0	QAM16	21.05	14.70
LTE Band26	3	27025	8	#Mid	QAM16	21.06	14.71
LTE Band26	3	27025	8	#Max	QAM16	21.08	14.73
LTE Band26	3	27025	15	#0	QAM16	20.92	14.57
LTE Band26	5	26815	1	#0	QPSK	22.47	16.12
LTE Band26	5	26815	1	#Mid	QPSK	22.37	16.02
LTE Band26	5	26815	1	#Max	QPSK	22.47	16.12
LTE Band26	5	26815	12	#0	QPSK	21.97	15.62
LTE Band26	5	26815	12	#Mid	QPSK	21.97	15.62
LTE Band26	5	26815	12	#Max	QPSK	21.50	15.15
LTE Band26	5	26815	25	#0	QPSK	21.55	15.20
LTE Band26	5	26815	1	#0	QAM16	21.55	15.20
LTE Band26	5	26815	1	#Mid	QAM16	21.17	14.82
LTE Band26	5	26815	1	#Max	QAM16	21.06	14.71
LTE Band26	5	26815	12	#0	QAM16	20.97	14.62
LTE Band26	5	26815	12	#Mid	QAM16	20.97	14.62
LTE Band26	5	26815	12	#Max	QAM16	20.93	14.58
LTE Band26	5	26815	25	#0	QAM16	21.02	14.67
LTE Band26	5	26915	1	#0	QPSK	22.55	16.20
LTE Band26	5	26915	1	#Mid	QPSK	22.54	16.19
LTE Band26	5	26915	1	#Max	QPSK	22.53	16.18
LTE Band26	5	26915	12	#0	QPSK	21.53	15.18
LTE Band26	5	26915	12	#Mid	QPSK	21.54	15.19
LTE Band26	5	26915	12	#Max	QPSK	21.94	15.59
LTE Band26	5	26915	25	#0	QPSK	22.00	15.65
LTE Band26	5	26915	1	#0	QAM16	21.68	15.33
LTE Band26	5	26915	1	#Mid	QAM16	22.10	15.75
LTE Band26	5	26915	1	#Max	QAM16	21.66	15.31
LTE Band26	5	26915	12	#0	QAM16	20.45	14.10
LTE Band26	5	26915	12	#Mid	QAM16	20.46	14.11
LTE Band26	5	26915	12	#Max	QAM16	20.95	14.60
LTE Band26	5	26915	25	#0	QAM16	20.85	14.50
LTE Band26	5	27015	1	#0	QPSK	22.42	16.07
LTE Band26	5	27015	1	#Mid	QPSK	22.42	16.07
LTE Band26	5	27015	1	#Max	QPSK	22.39	16.04
LTE Band26	5	27015	12	#0	QPSK	21.37	15.02
LTE Band26	5	27015	12	#Mid	QPSK	21.39	15.04
LTE Band26	5	27015	12	#Max	QPSK	21.88	15.53
LTE Band26	5	27015	25	#0	QPSK	22.01	15.66
LTE Band26	5	27015	1	#0	QAM16	21.34	14.99
LTE Band26	5	27015	1	#Mid	QAM16	21.85	15.50
LTE Band26	5	27015	1	#Max	QAM16	21.42	15.07



LTE Band26	5	27015	12	#0	QAM16	20.91	14.56
LTE Band26	5	27015	12	#Mid	QAM16	20.92	14.57
LTE Band26	5	27015	12	#Max	QAM16	20.89	14.54
LTE Band26	5	27015	25	#0	QAM16	20.85	14.50
LTE Band26	10	26840	1	#0	QPSK	22.57	16.22
LTE Band26	10	26840	1	#Mid	QPSK	22.54	16.19
LTE Band26	10	26840	1	#Max	QPSK	22.47	16.12
LTE Band26	10	26840	25	#0	QPSK	21.62	15.27
LTE Band26	10	26840	25	#Mid	QPSK	21.62	15.27
LTE Band26	10	26840	25	#Max	QPSK	21.96	15.61
LTE Band26	10	26840	50	#0	QPSK	21.56	15.21
LTE Band26	10	26840	1	#0	QAM16	21.86	15.51
LTE Band26	10	26840	1	#Mid	QAM16	21.46	15.11
LTE Band26	10	26840	1	#Max	QAM16	21.34	14.99
LTE Band26	10	26840	25	#0	QAM16	21.11	14.76
LTE Band26	10	26840	25	#Mid	QAM16	21.11	14.76
LTE Band26	10	26840	25	#Max	QAM16	20.99	14.64
LTE Band26	10	26840	50	#0	QAM16	20.54	14.19
LTE Band26	10	26915	1	#0	QPSK	22.55	16.20
LTE Band26	10	26915	1	#Mid	QPSK	22.51	16.16
LTE Band26	10	26915	1	#Max	QPSK	22.60	16.25
LTE Band26	10	26915	25	#0	QPSK	21.64	15.29
LTE Band26	10	26915	25	#Mid	QPSK	21.64	15.29
LTE Band26	10	26915	25	#Max	QPSK	21.57	15.22
LTE Band26	10	26915	50	#0	QPSK	22.02	15.67
LTE Band26	10	26915	1	#0	QAM16	22.61	16.26
LTE Band26	10	26915	1	#Mid	QAM16	22.65	16.30
LTE Band26	10	26915	1	#Max	QAM16	22.62	16.27
LTE Band26	10	26915	25	#0	QAM16	20.59	14.24
LTE Band26	10	26915	25	#Mid	QAM16	20.51	14.16
LTE Band26	10	26915	25	#Max	QAM16	20.99	14.64
LTE Band26	10	26915	50	#0	QAM16	20.93	14.58
LTE Band26	10	26990	1	#0	QPSK	22.56	16.21
LTE Band26	10	26990	1	#Mid	QPSK	22.60	16.25
LTE Band26	10	26990	1	#Max	QPSK	22.59	16.24
LTE Band26	10	26990	25	#0	QPSK	21.87	15.52
LTE Band26	10	26990	25	#Mid	QPSK	21.89	15.54
LTE Band26	10	26990	25	#Max	QPSK	21.96	15.61
LTE Band26	10	26990	50	#0	QPSK	21.47	15.12
LTE Band26	10	26990	1	#0	QAM16	20.98	14.63
LTE Band26	10	26990	1	#Mid	QAM16	21.05	14.70
LTE Band26	10	26990	1	#Max	QAM16	20.91	14.56
LTE Band26	10	26990	25	#0	QAM16	21.06	14.71



LTE Band26	10	26990	25	#Mid	QAM16	20.72	14.37
LTE Band26	10	26990	25	#Max	QAM16	18.60	12.25
LTE Band26	10	26990	50	#0	QAM16	18.96	12.61
LTE Band26	15	26865	1	#0	QPSK	20.87	14.52
LTE Band26	15	26865	1	#Mid	QPSK	20.90	14.55
LTE Band26	15	26865	1	#Max	QPSK	20.88	14.53
LTE Band26	15	26865	36	#0	QPSK	19.52	13.17
LTE Band26	15	26865	36	#Mid	QPSK	19.46	13.11
LTE Band26	15	26865	36	#Max	QPSK	19.38	13.03
LTE Band26	15	26865	75	#0	QPSK	19.98	13.63
LTE Band26	15	26865	1	#0	QAM16	19.83	13.48
LTE Band26	15	26865	1	#Mid	QAM16	19.77	13.42
LTE Band26	15	26865	1	#Max	QAM16	19.73	13.38
LTE Band26	15	26865	36	#0	QAM16	18.98	12.63
LTE Band26	15	26865	36	#Mid	QAM16	19.01	12.66
LTE Band26	15	26865	36	#Max	QAM16	20.52	14.17
LTE Band26	15	26865	75	#0	QAM16	21.00	14.65
LTE Band26	15	26915	1	#0	QPSK	22.67	16.32
LTE Band26	15	26915	1	#Mid	QPSK	22.66	16.31
LTE Band26	15	26915	1	#Max	QPSK	22.63	16.28
LTE Band26	15	26915	36	#0	QPSK	21.64	15.29
LTE Band26	15	26915	36	#Mid	QPSK	21.63	15.28
LTE Band26	15	26915	36	#Max	QPSK	21.89	15.54
LTE Band26	15	26915	75	#0	QPSK	22.05	15.70
LTE Band26	15	26915	1	#0	QAM16	21.61	15.26
LTE Band26	15	26915	1	#Mid	QAM16	22.08	15.73
LTE Band26	15	26915	1	#Max	QAM16	21.57	15.22
LTE Band26	15	26915	36	#0	QAM16	20.61	14.26
LTE Band26	15	26915	36	#Mid	QAM16	20.65	14.30
LTE Band26	15	26915	36	#Max	QAM16	21.05	14.70
LTE Band26	15	26915	75	#0	QAM16	20.87	14.52
LTE Band26	15	26965	1	#0	QPSK	22.52	16.17
LTE Band26	15	26965	1	#Mid	QPSK	22.56	16.21
LTE Band26	15	26965	1	#Max	QPSK	22.45	16.10
LTE Band26	15	26965	36	#0	QPSK	21.53	15.18
LTE Band26	15	26965	36	#Mid	QPSK	21.54	15.19
LTE Band26	15	26965	36	#Max	QPSK	21.55	15.20
LTE Band26	15	26965	75	#0	QPSK	21.85	15.50
LTE Band26	15	26965	1	#0	QAM16	21.34	14.99
LTE Band26	15	26965	1	#Mid	QAM16	21.72	15.37
LTE Band26	15	26965	1	#Max	QAM16	21.26	14.91
LTE Band26	15	26965	36	#0	QAM16	20.97	14.62
LTE Band26	15	26965	36	#Mid	QAM16	20.98	14.63



LTE Band26	15	26965	36	#Max	QAM16	20.97	14.62
LTE Band26	15	26965	75	#0	QAM16	20.89	14.54
LTE Band26	1.4	26797	1	#0	QAM64	22.12	15.77
LTE Band26	1.4	26797	1	#Mid	QAM64	22.18	15.83
LTE Band26	1.4	26797	1	#Max	QAM64	22.20	15.85
LTE Band26	1.4	26797	3	#0	QAM64	21.60	15.25
LTE Band26	1.4	26797	3	#Mid	QAM64	21.61	15.26
LTE Band26	1.4	26797	3	#Max	QAM64	21.75	15.40
LTE Band26	1.4	26797	6	#0	QAM64	20.84	14.49
LTE Band26	1.4	26915	1	#0	QAM64	21.96	15.61
LTE Band26	1.4	26915	1	#Mid	QAM64	22.35	16.00
LTE Band26	1.4	26915	1	#Max	QAM64	22.29	15.94
LTE Band26	1.4	26915	3	#0	QAM64	21.61	15.26
LTE Band26	1.4	26915	3	#Mid	QAM64	21.59	15.24
LTE Band26	1.4	26915	3	#Max	QAM64	21.57	15.22
LTE Band26	1.4	26915	6	#0	QAM64	20.58	14.23
LTE Band26	1.4	27033	1	#0	QAM64	21.24	14.89
LTE Band26	1.4	27033	1	#Mid	QAM64	20.81	14.46
LTE Band26	1.4	27033	1	#Max	QAM64	20.82	14.47
LTE Band26	1.4	27033	3	#0	QAM64	21.61	15.26
LTE Band26	1.4	27033	3	#Mid	QAM64	21.63	15.28
LTE Band26	1.4	27033	3	#Max	QAM64	21.25	14.90
LTE Band26	1.4	27033	6	#0	QAM64	20.84	14.49
LTE Band26	3	26805	1	#0	QAM64	21.66	15.31
LTE Band26	3	26805	1	#Mid	QAM64	21.60	15.25
LTE Band26	3	26805	1	#Max	QAM64	21.26	14.91
LTE Band26	3	26805	8	#0	QAM64	20.89	14.54
LTE Band26	3	26805	8	#Mid	QAM64	20.88	14.53
LTE Band26	3	26805	8	#Max	QAM64	20.85	14.50
LTE Band26	3	26805	15	#0	QAM64	20.59	14.24
LTE Band26	3	26915	1	#0	QAM64	21.88	15.53
LTE Band26	3	26915	1	#Mid	QAM64	22.39	16.04
LTE Band26	3	26915	1	#Max	QAM64	22.33	15.98
LTE Band26	3	26915	8	#0	QAM64	20.28	13.93
LTE Band26	3	26915	8	#Mid	QAM64	20.26	13.91
LTE Band26	3	26915	8	#Max	QAM64	20.67	14.32
LTE Band26	3	26915	15	#0	QAM64	20.62	14.27
LTE Band26	3	27025	1	#0	QAM64	21.08	14.73
LTE Band26	3	27025	1	#Mid	QAM64	21.07	14.72
LTE Band26	3	27025	1	#Max	QAM64	20.65	14.30
LTE Band26	3	27025	8	#0	QAM64	20.76	14.41
LTE Band26	3	27025	8	#Mid	QAM64	20.77	14.42
LTE Band26	3	27025	8	#Max	QAM64	20.69	14.34



LTE Band26	3	27025	15	#0	QAM64	20.49	14.14
LTE Band26	5	26815	1	#0	QAM64	21.24	14.89
LTE Band26	5	26815	1	#Mid	QAM64	20.80	14.45
LTE Band26	5	26815	1	#Max	QAM64	20.75	14.40
LTE Band26	5	26815	12	#0	QAM64	20.62	14.27
LTE Band26	5	26815	12	#Mid	QAM64	20.60	14.25
LTE Band26	5	26815	12	#Max	QAM64	20.66	14.31
LTE Band26	5	26815	25	#0	QAM64	20.70	14.35
LTE Band26	5	26915	1	#0	QAM64	21.46	15.11
LTE Band26	5	26915	1	#Mid	QAM64	21.71	15.36
LTE Band26	5	26915	1	#Max	QAM64	21.40	15.05
LTE Band26	5	26915	12	#0	QAM64	20.15	13.80
LTE Band26	5	26915	12	#Mid	QAM64	20.16	13.81
LTE Band26	5	26915	12	#Max	QAM64	20.56	14.21
LTE Band26	5	26915	25	#0	QAM64	20.60	14.25
LTE Band26	5	27015	1	#0	QAM64	21.21	14.86
LTE Band26	5	27015	1	#Mid	QAM64	21.72	15.37
LTE Band26	5	27015	1	#Max	QAM64	21.23	14.88
LTE Band26	5	27015	12	#0	QAM64	20.71	14.36
LTE Band26	5	27015	12	#Mid	QAM64	20.70	14.35
LTE Band26	5	27015	12	#Max	QAM64	20.69	14.34
LTE Band26	5	27015	25	#0	QAM64	20.65	14.30
LTE Band26	10	26840	1	#0	QAM64	21.54	15.19
LTE Band26	10	26840	1	#Mid	QAM64	21.09	14.74
LTE Band26	10	26840	1	#Max	QAM64	20.99	14.64
LTE Band26	10	26840	25	#0	QAM64	20.72	14.37
LTE Band26	10	26840	25	#Mid	QAM64	20.71	14.36
LTE Band26	10	26840	25	#Max	QAM64	20.72	14.37
LTE Band26	10	26840	50	#0	QAM64	20.29	13.94
LTE Band26	10	26915	1	#0	QAM64	21.76	15.41
LTE Band26	10	26915	1	#Mid	QAM64	21.71	15.36
LTE Band26	10	26915	1	#Max	QAM64	21.72	15.37
LTE Band26	10	26915	25	#0	QAM64	20.32	13.97
LTE Band26	10	26915	25	#Mid	QAM64	20.34	13.99
LTE Band26	10	26915	25	#Max	QAM64	20.77	14.42
LTE Band26	10	26915	50	#0	QAM64	20.60	14.25
LTE Band26	10	26990	1	#0	QAM64	20.71	14.36
LTE Band26	10	26990	1	#Mid	QAM64	20.66	14.31
LTE Band26	10	26990	1	#Max	QAM64	20.49	14.14
LTE Band26	10	26990	25	#0	QAM64	20.75	14.40
LTE Band26	10	26990	25	#Mid	QAM64	20.74	14.39
LTE Band26	10	26990	25	#Max	QAM64	20.70	14.35
LTE Band26	10	26990	50	#0	QAM64	20.61	14.26



LTE Band26	15	26865	1	#0	QAM64	21.57	15.22
LTE Band26	15	26865	1	#Mid	QAM64	21.50	15.15
LTE Band26	15	26865	1	#Max	QAM64	21.16	14.81
LTE Band26	15	26865	36	#0	QAM64	20.13	13.78
LTE Band26	15	26865	36	#Mid	QAM64	20.13	13.78
LTE Band26	15	26865	36	#Max	QAM64	20.11	13.76
LTE Band26	15	26865	75	#0	QAM64	20.65	14.30
LTE Band26	15	26915	1	#0	QAM64	21.34	14.99
LTE Band26	15	26915	1	#Mid	QAM64	21.75	15.40
LTE Band26	15	26915	1	#Max	QAM64	21.30	14.95
LTE Band26	15	26915	36	#0	QAM64	20.37	14.02
LTE Band26	15	26915	36	#Mid	QAM64	20.28	13.93
LTE Band26	15	26915	36	#Max	QAM64	20.64	14.29
LTE Band26	15	26915	75	#0	QAM64	20.59	14.24
LTE Band26	15	26965	1	#0	QAM64	21.19	14.84
LTE Band26	15	26965	1	#Mid	QAM64	21.59	15.24
LTE Band26	15	26965	1	#Max	QAM64	21.14	14.79
LTE Band26	15	26965	36	#0	QAM64	20.68	14.33
LTE Band26	15	26965	36	#Mid	QAM64	20.69	14.34
LTE Band26	15	26965	36	#Max	QAM64	20.67	14.32
LTE Band26	15	26965	75	#0	QAM64	20.66	14.31

6.2. Occupied Bandwidth

LTE Band 26						
RB	Modulation	Bandwidth (MHz)	Channel	Frequency (MHz)	99% Power Bandwidth(MHz)	-26dBc Bandwidth(MHz)
100%	QPSK	1.4	26797	824.7	1.094	1.233
			26915	836.5	1.095	1.240
			27033	848.3	1.094	1.246
		3	26805	825.5	2.712	3.047
			26915	836.5	2.716	3.023
			27025	847.5	2.715	3.040
		5	26815	826.5	4.512	4.958
			26915	836.5	4.508	4.955
			27015	846.5	4.517	4.951
		10	26840	829	9.002	9.803
			26915	836.5	8.997	9.772
			26990	844	8.965	9.873
		15	26865	831.5	13.448	14.843
			26915	836.5	13.420	14.719
			26965	841.5	13.454	14.665
	16QAM	1.4	26797	824.7	1.106	1.251
			26915	836.5	1.098	1.242
			27033	848.3	1.091	1.223
		3	26805	825.5	2.707	3.030
			26915	836.5	2.697	3.037
			27025	847.5	2.709	3.060
		5	26815	826.5	4.512	4.910
			26915	836.5	4.504	4.919
			27015	846.5	4.525	4.966
		10	26840	829	9.002	9.877
			26915	836.5	8.982	9.816
			26990	844	8.992	9.834
15	26865	831.5	13.452	14.914		
	26915	836.5	13.450	14.780		



			26965	841.5	13.424	14.775
64QAM	1.4		26797	824.7	1.109	1.259
			26915	836.5	1.090	1.248
			27033	848.3	1.099	1.241
	3		26805	825.5	2.711	3.022
			26915	836.5	2.716	3.052
			27025	847.5	2.704	3.041
	5		26815	826.5	4.512	4.940
			26915	836.5	4.516	4.969
			27015	846.5	4.508	5.013
	10		26840	829	8.993	9.927
			26915	836.5	8.999	9.839
			26990	844	8.989	9.878
	15		26865	831.5	13.503	14.800
			26915	836.5	13.456	14.764
			26965	841.5	13.454	14.841

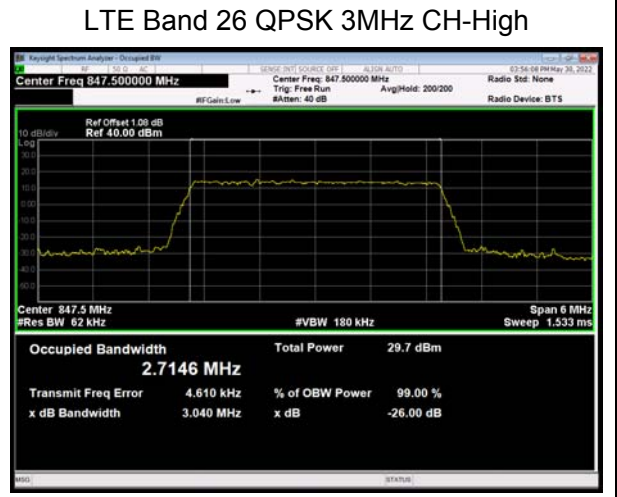
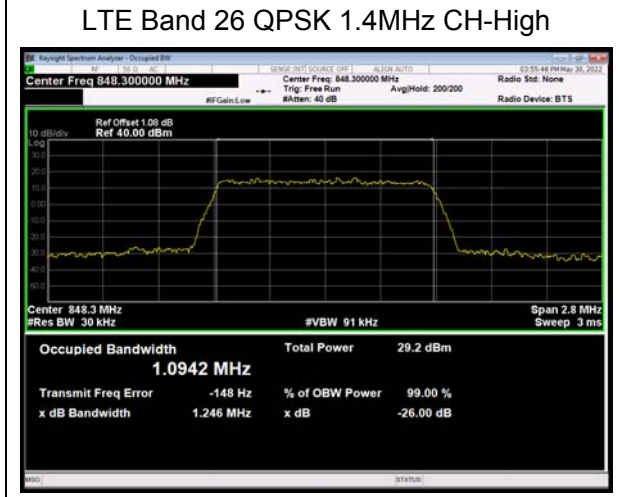
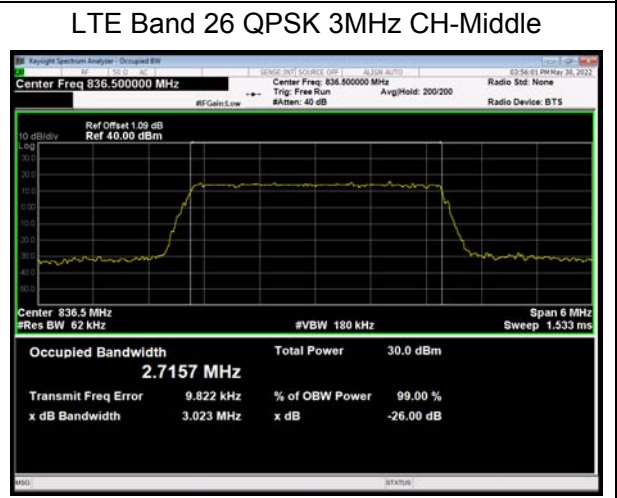
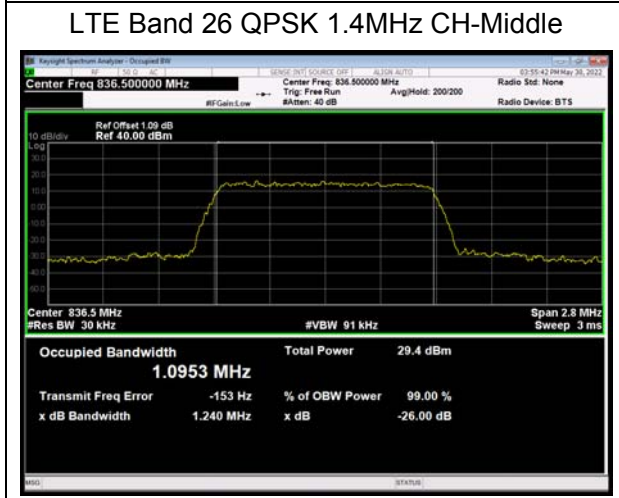
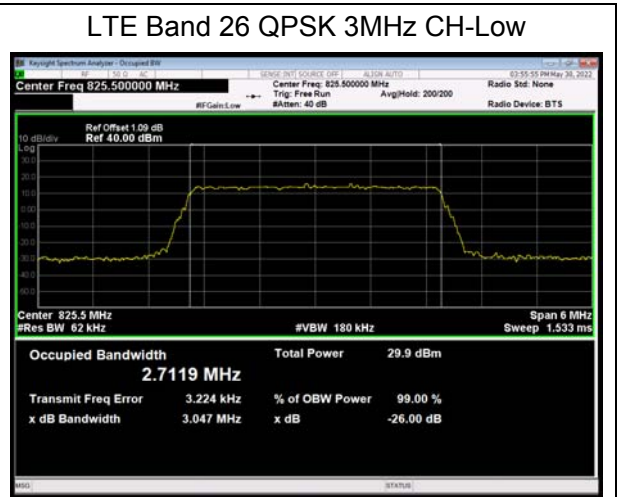
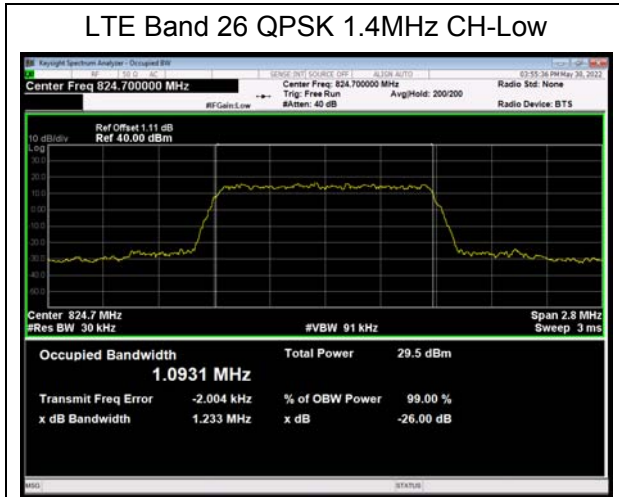

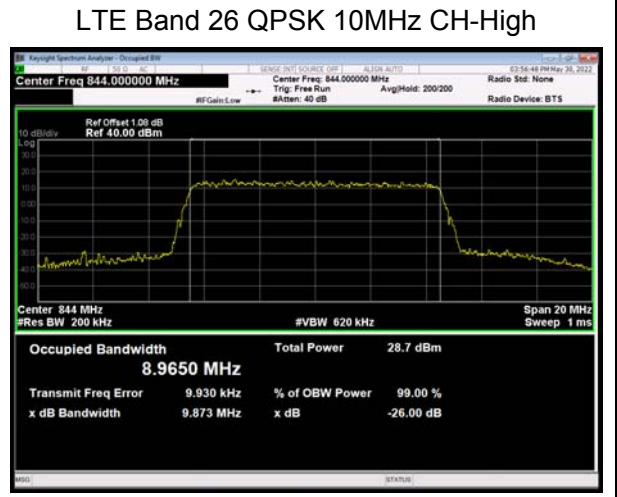
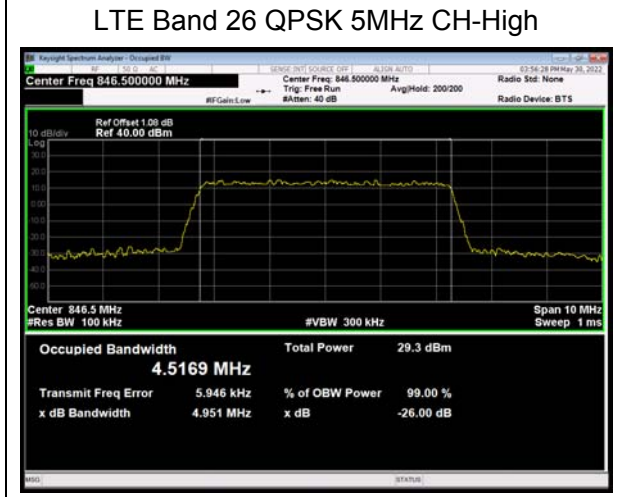
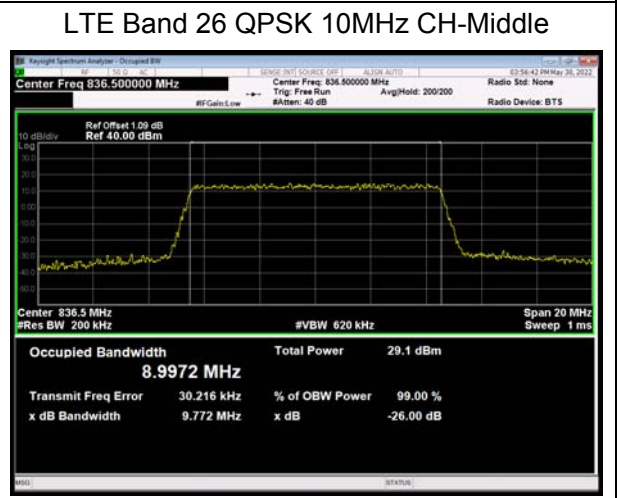
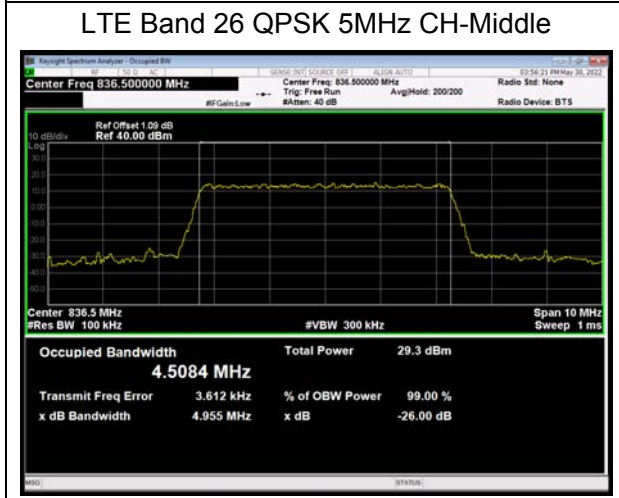
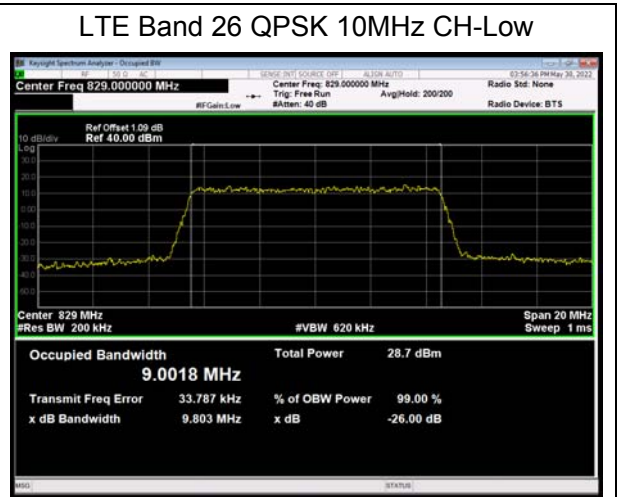
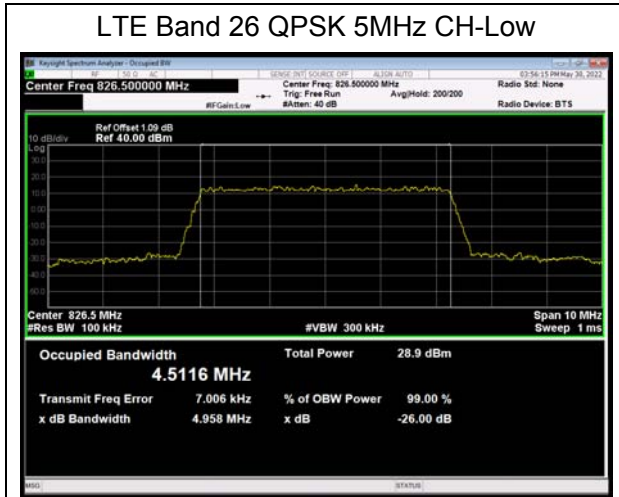

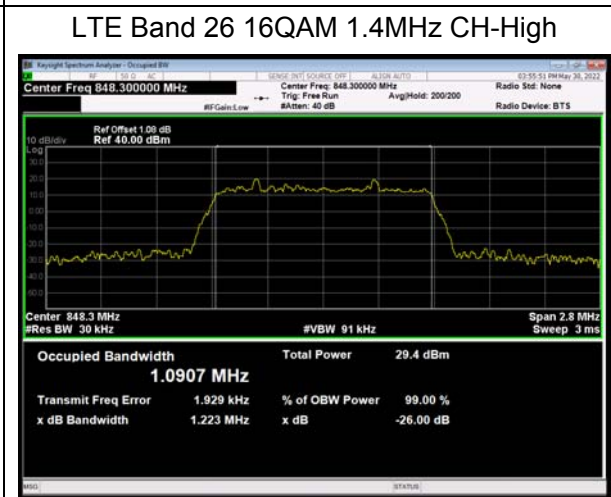
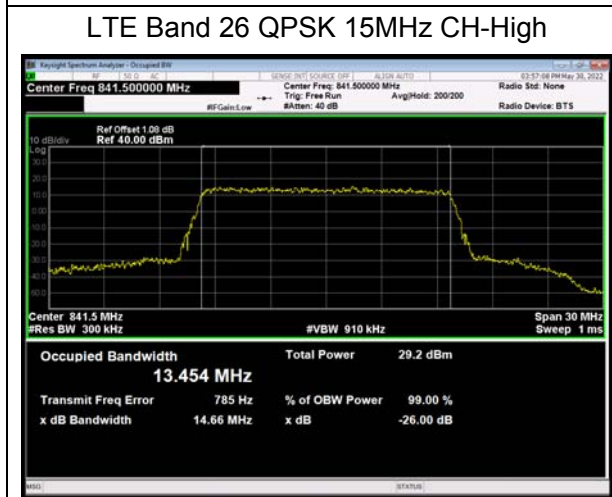
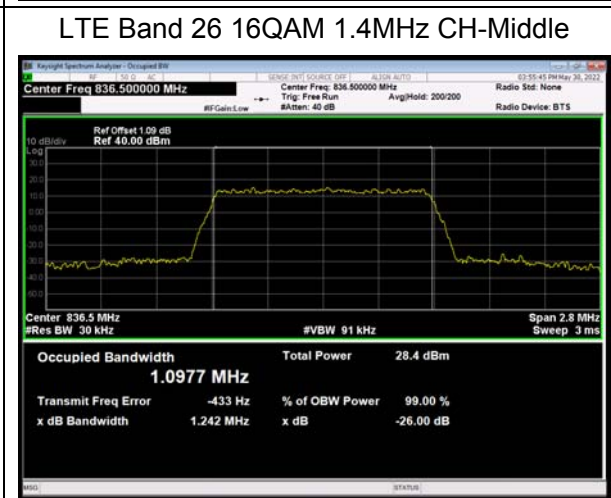
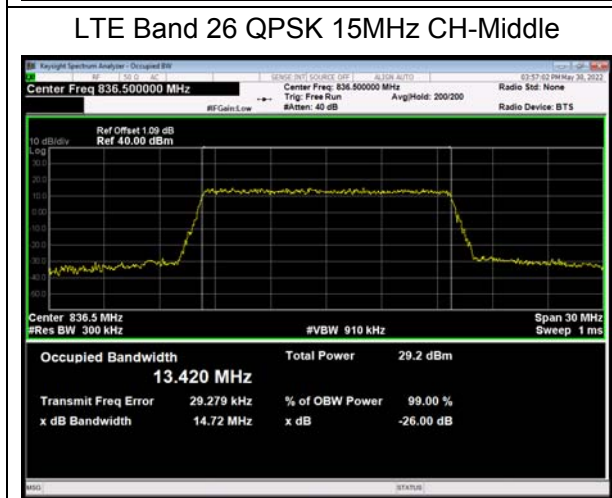
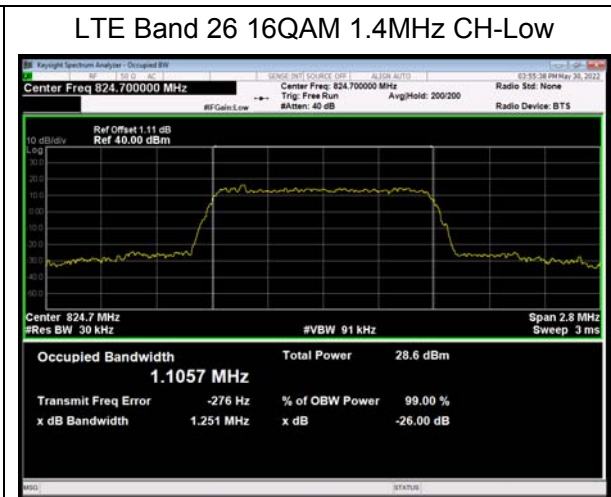
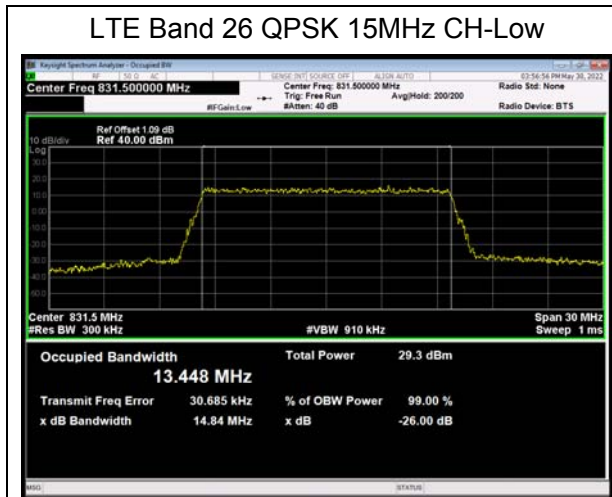

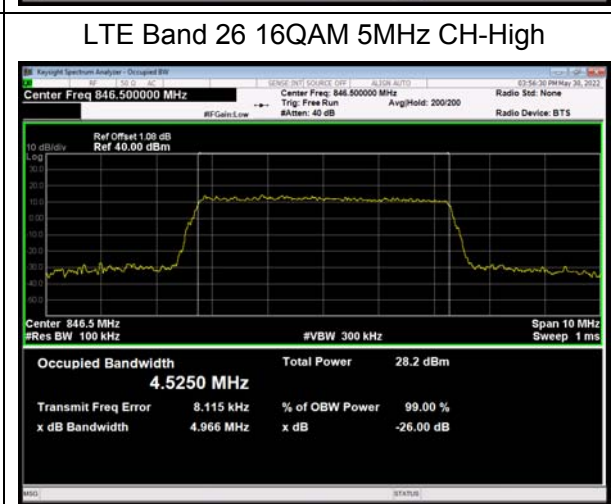
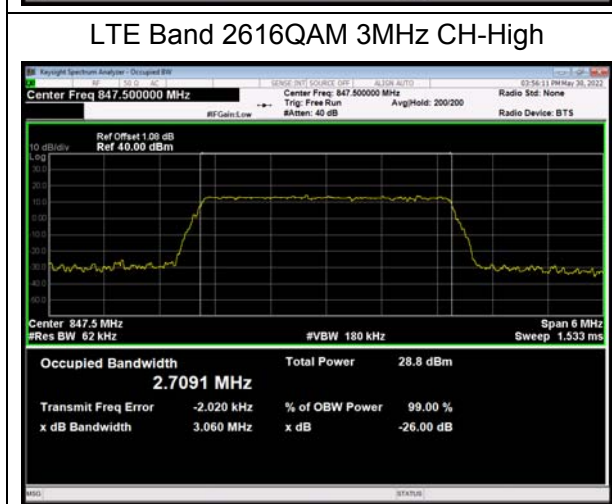
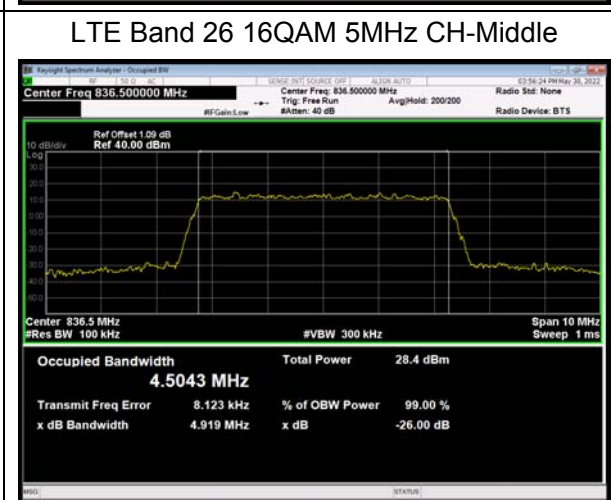
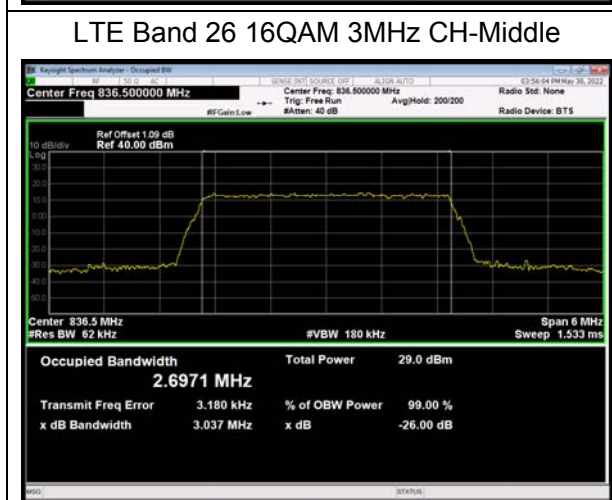
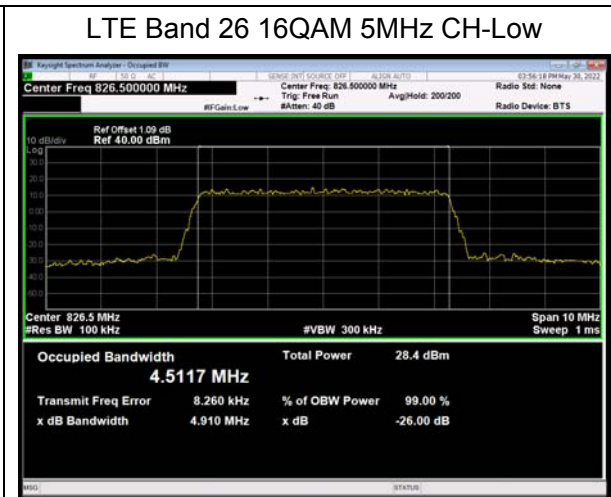
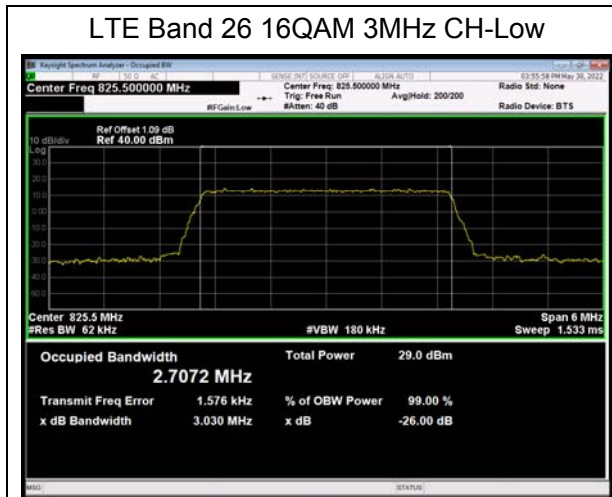

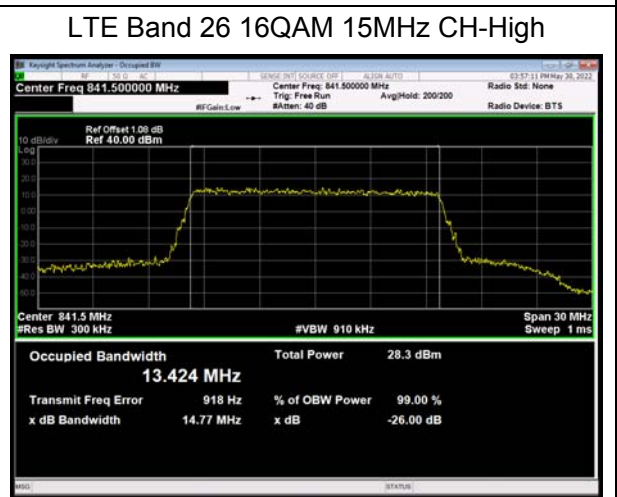
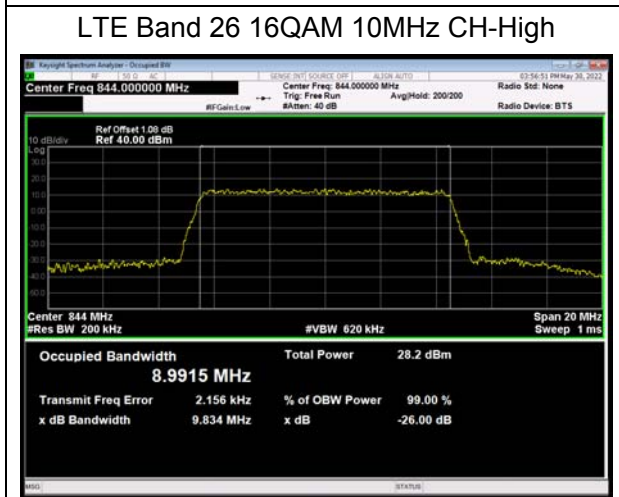
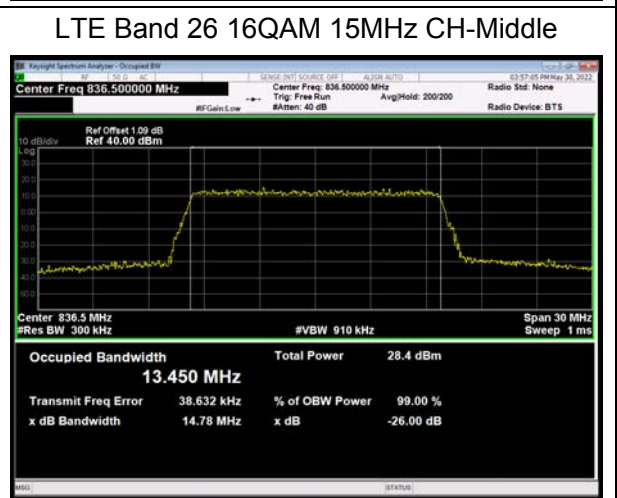
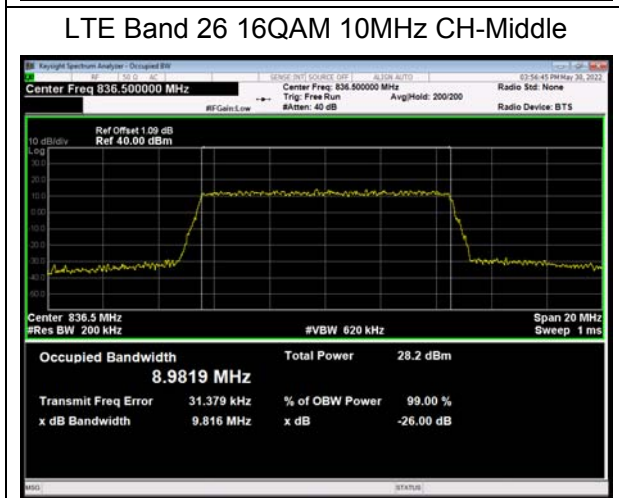
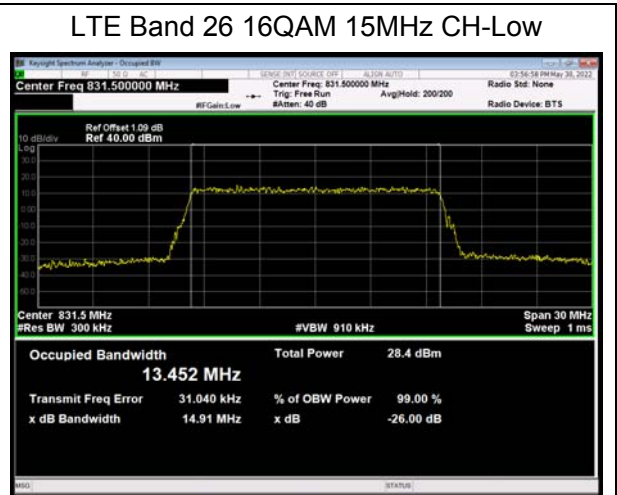
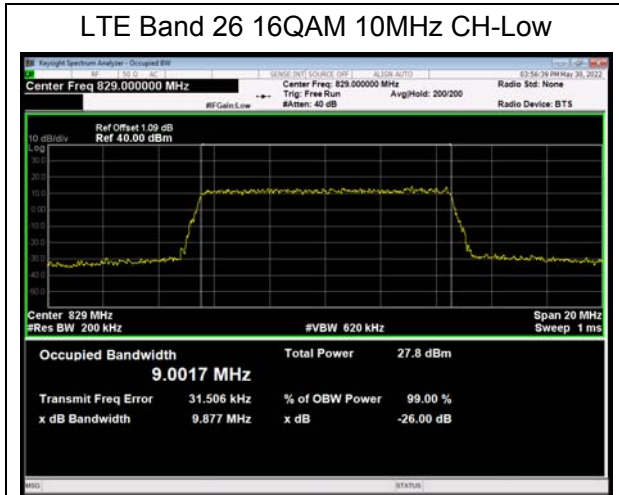

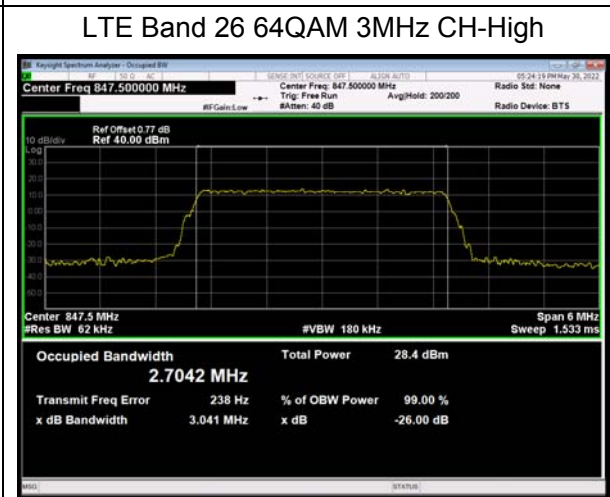
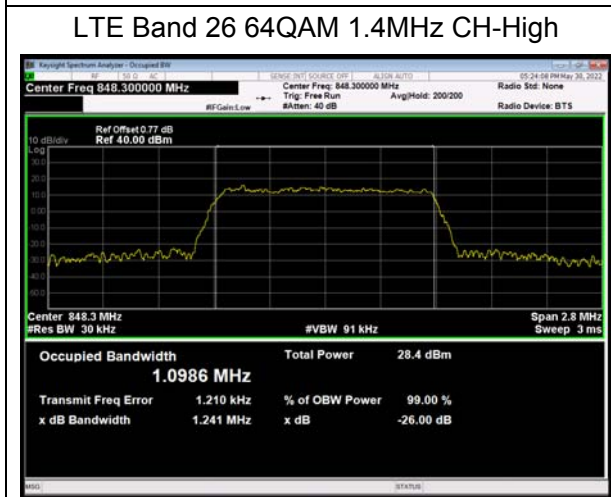
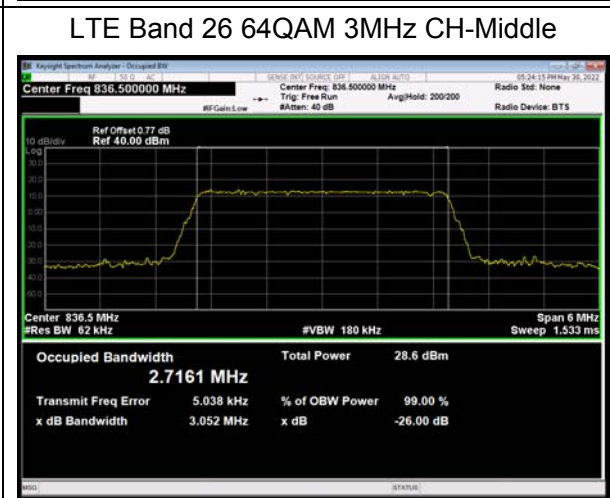
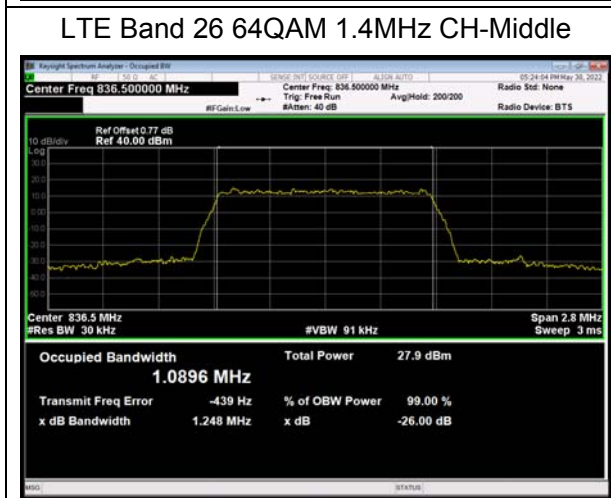
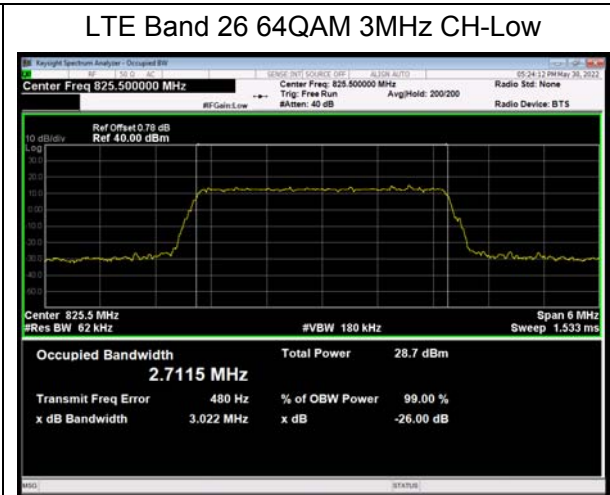
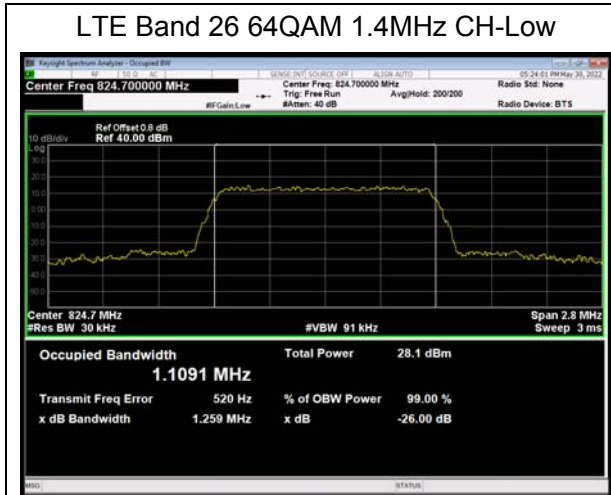

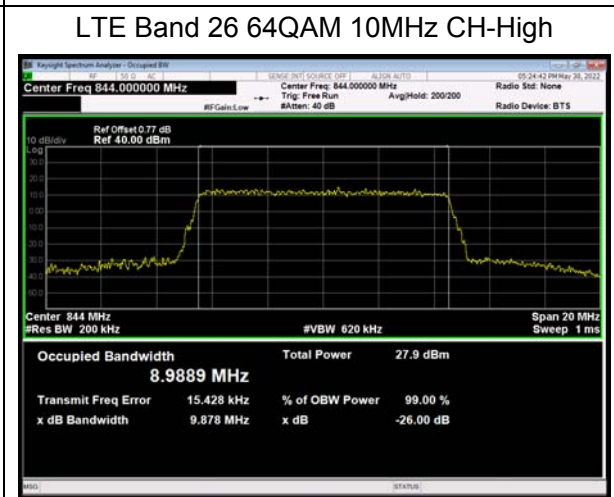
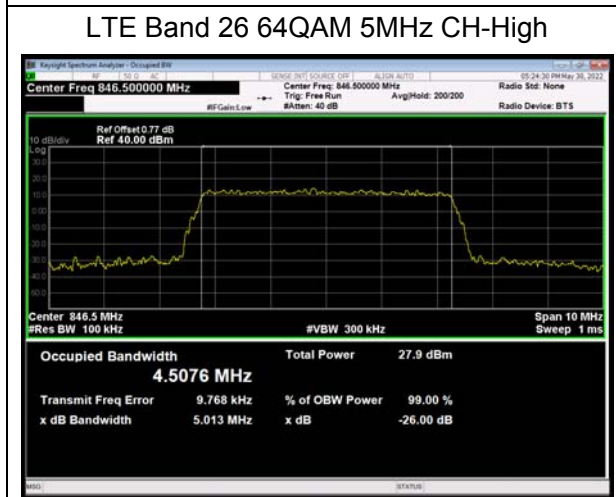
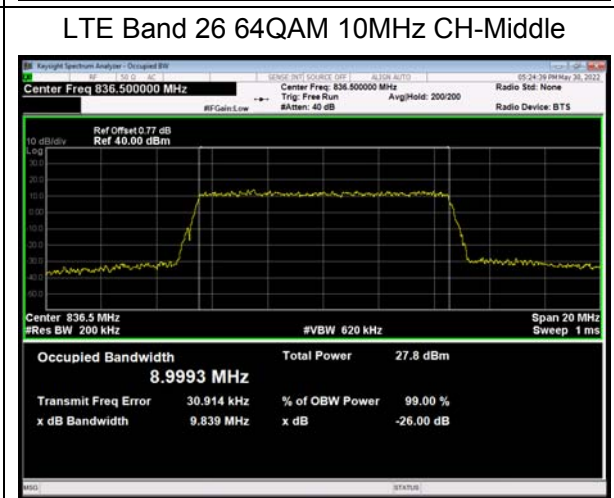
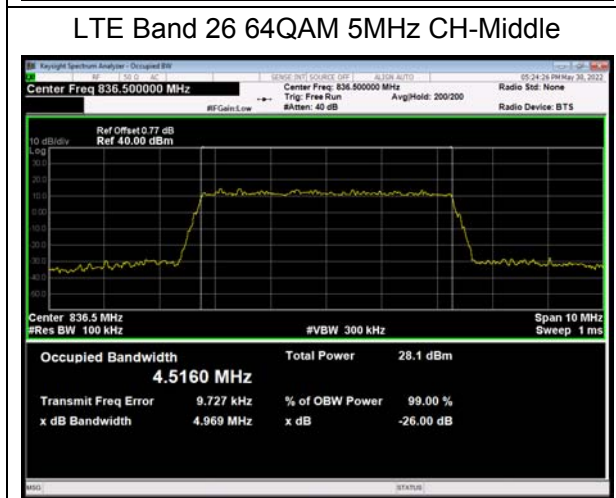
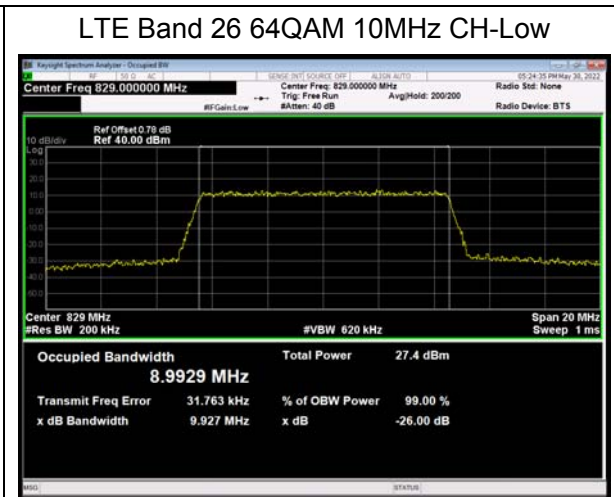
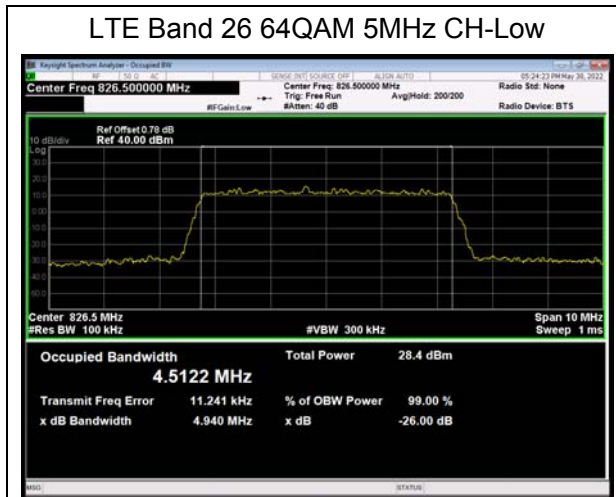

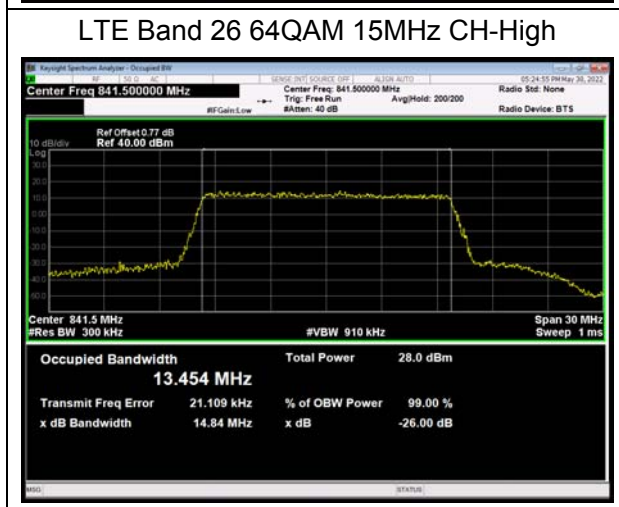
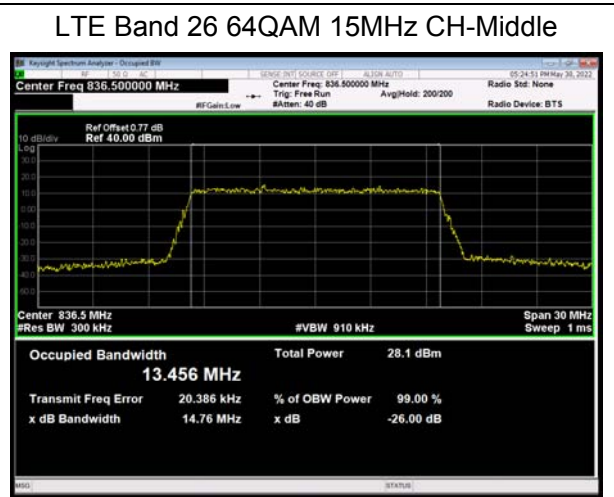
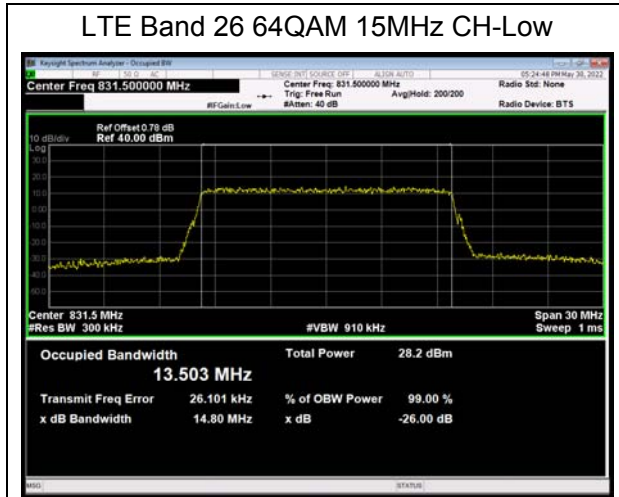

6.3. Band Edge Compliance

LTE Band 26 QPSK 1.4MHz CH-Low 1RB

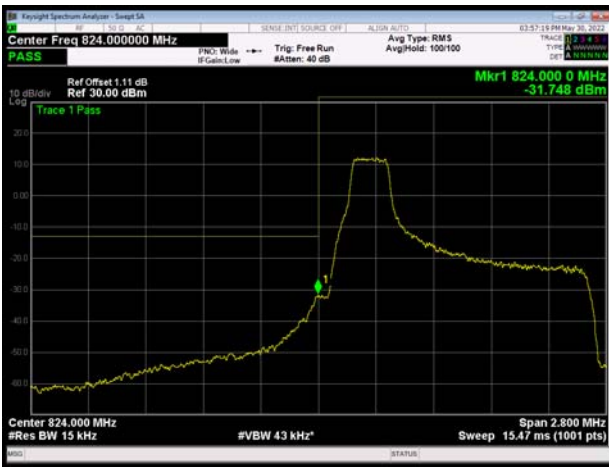

LTE Band 26 QPSK 1.4MHz CH-High 1RB

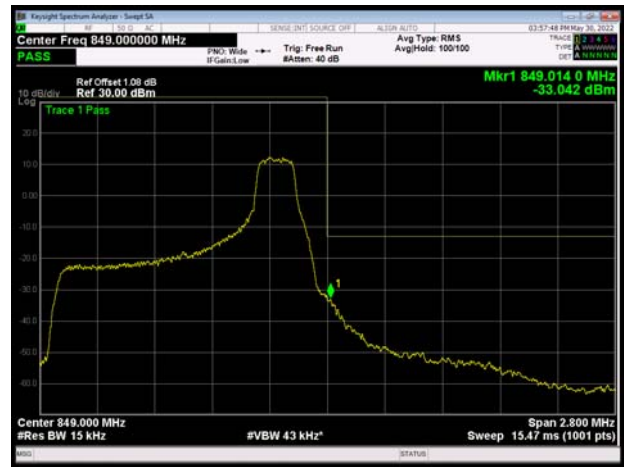

LTE Band 26 QPSK 1.4MHz CH-Low 100%RB

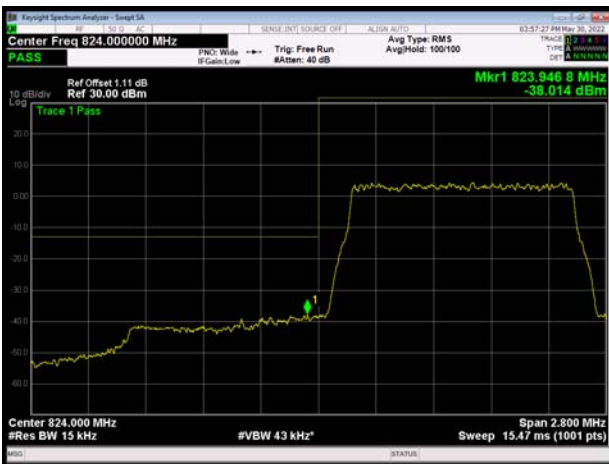

LTE Band 26 QPSK 1.4MHz CH-High 100%RB



LTE Band 26 QPSK 3MHz CH-Low 1RB

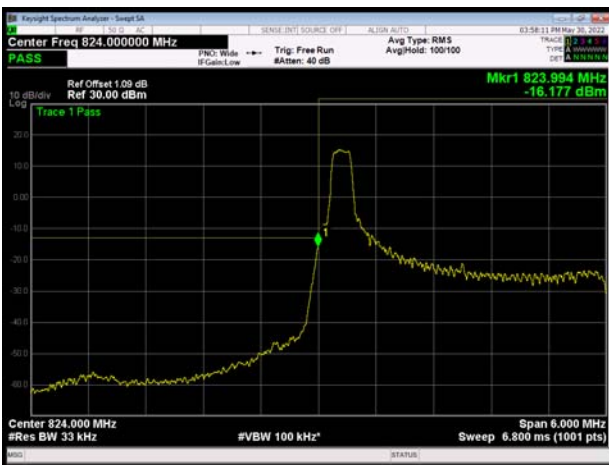

LTE Band 26 QPSK 3MHz CH-High 1RB

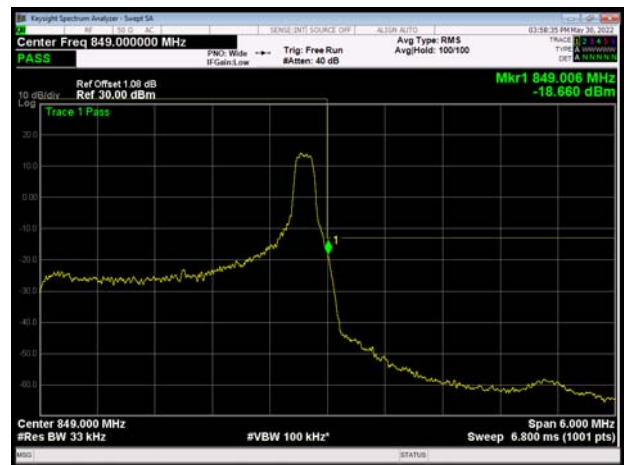



LTE Band 26 QPSK 3MHz CH-Low 100%RB

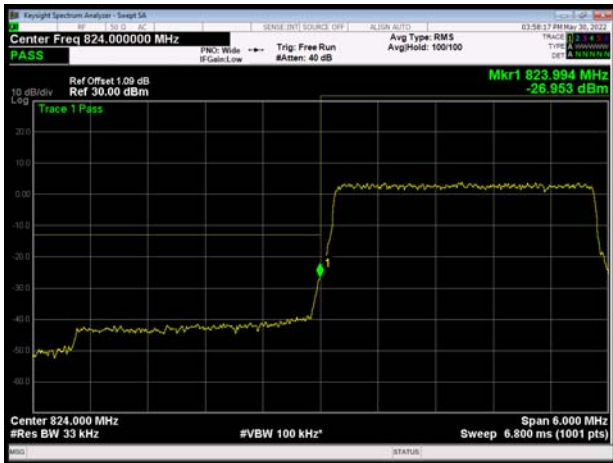

LTE Band 26 QPSK 3MHz CH-High 100%RB

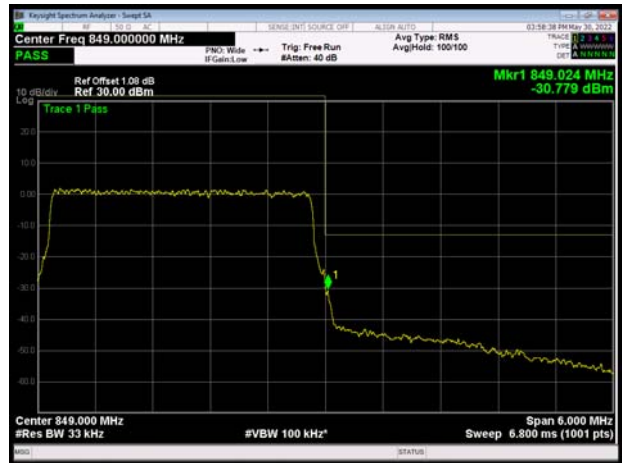

LTE Band 26 QPSK 5MHz CH-Low 1RB

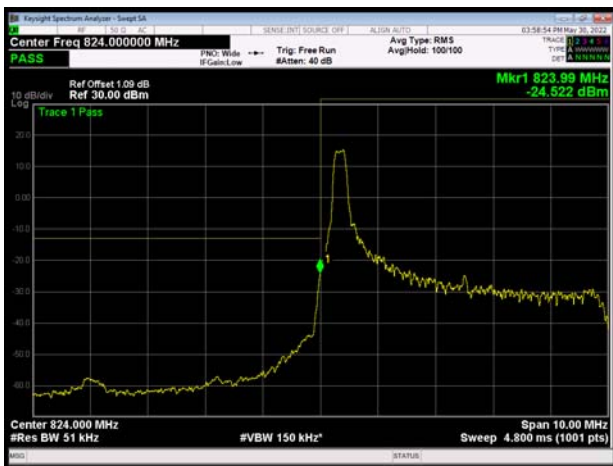

LTE Band 26 QPSK 5MHz CH-High 1RB

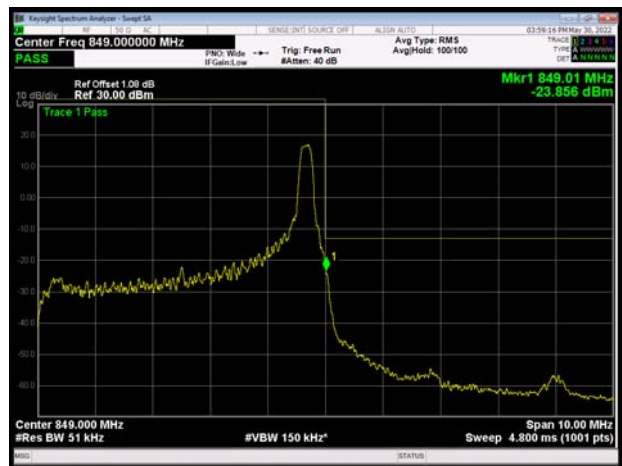

LTE Band 26 QPSK 5MHz CH-Low 100%RB

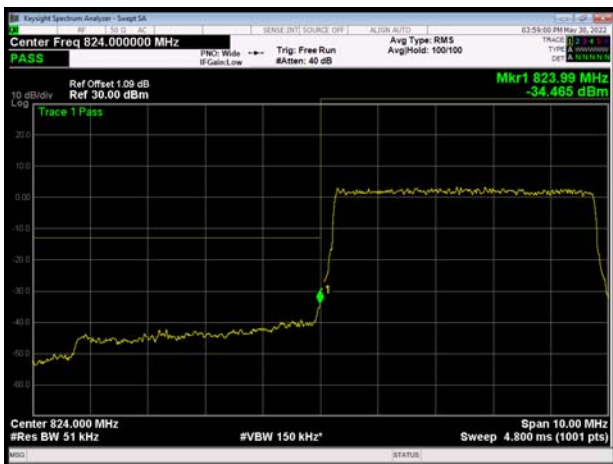

LTE Band 26 QPSK 5MHz CH-High 100%RB

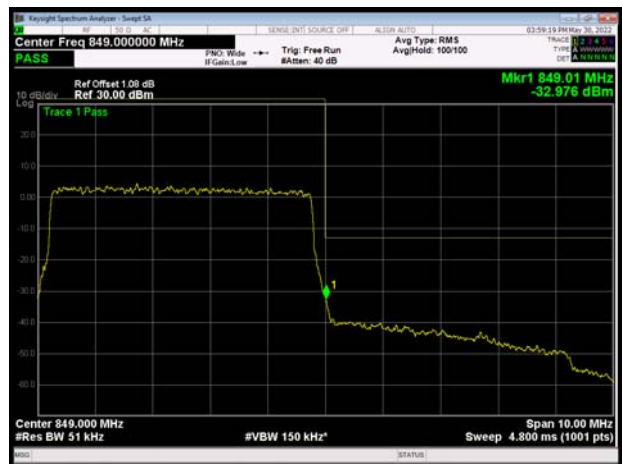

LTE Band 26 QPSK 10MHz CH-Low 1RB

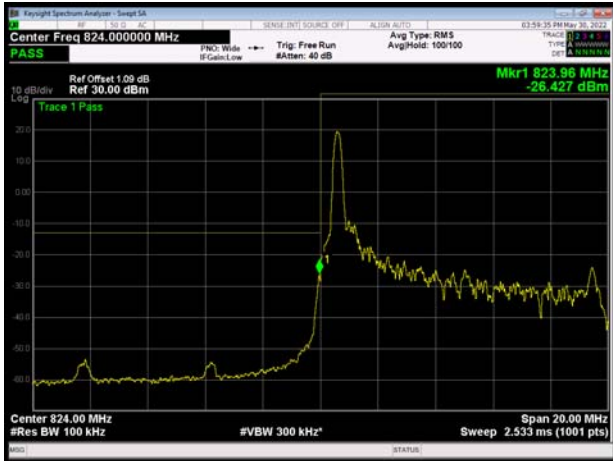

LTE Band 26 QPSK 10MHz CH-High 1RB

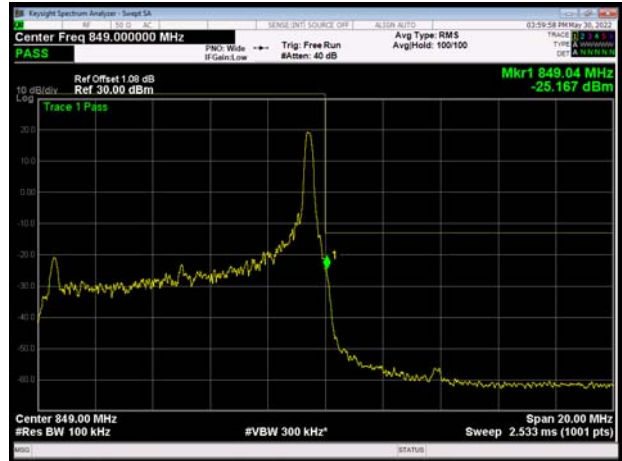

LTE Band 26 QPSK 10MHz CH-Low 100%RB

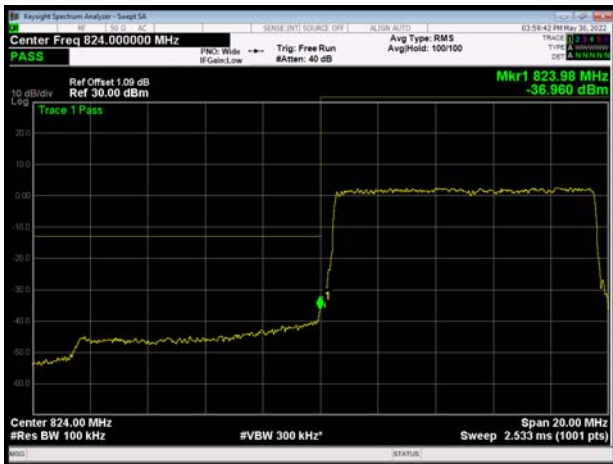

LTE Band 26 QPSK 10MHz CH-High 100%RB



LTE Band 26 QPSK 15MHz CH-Low 1RB

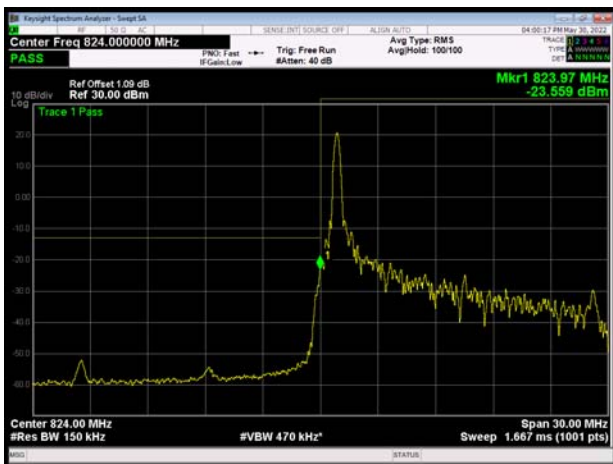

LTE Band 26 QPSK 15MHz CH-High 1RB

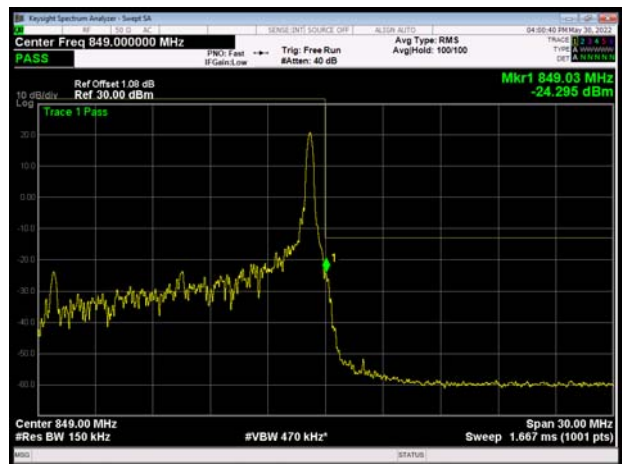

LTE Band 26 QPSK 15MHz CH-Low 100%RB

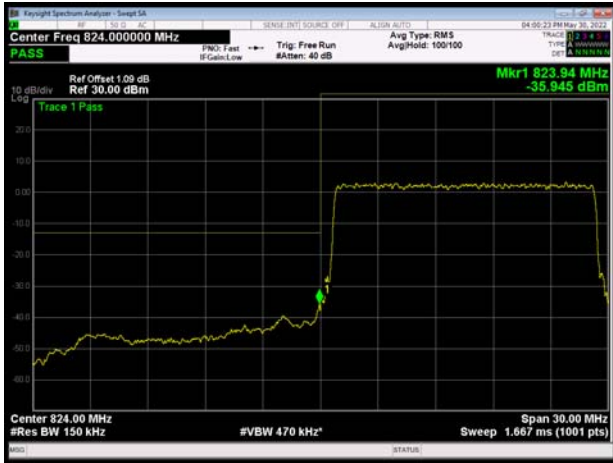

LTE Band 26 QPSK 15MHz CH-High 100%RB



LTE Band 26 16QAM 1.4MHz CH-Low 1RB

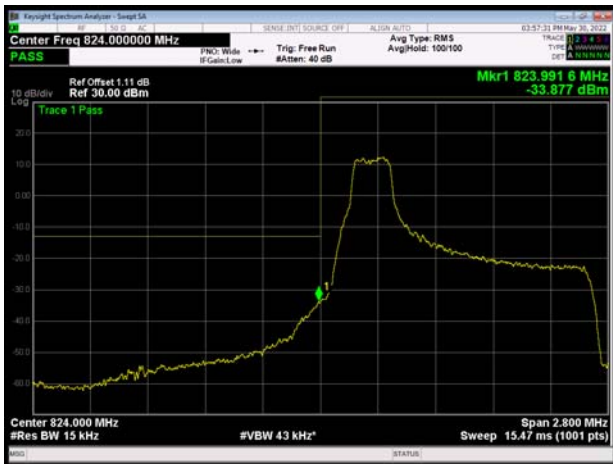

LTE Band 26 16QAM 1.4MHz CH-High 1RB

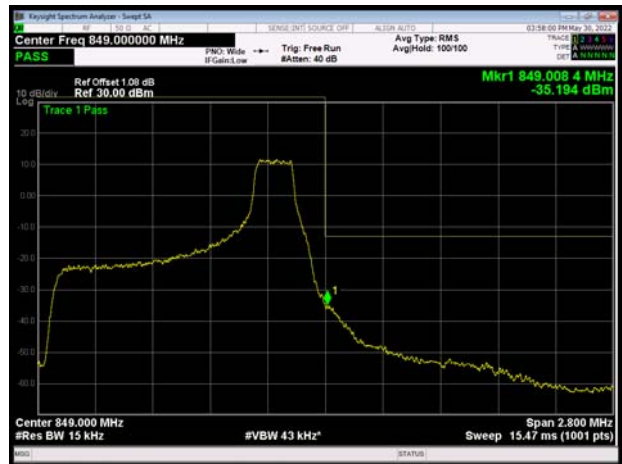

LTE Band 26 16QAM 1.4MHz CH-Low 100%RB

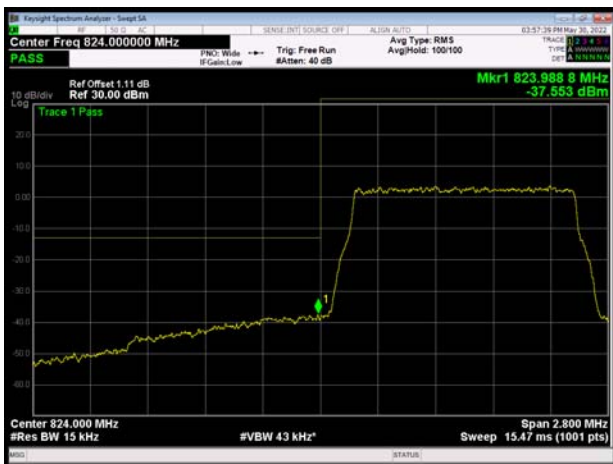

LTE Band 26 16QAM 1.4MHz CH-High 100%RB

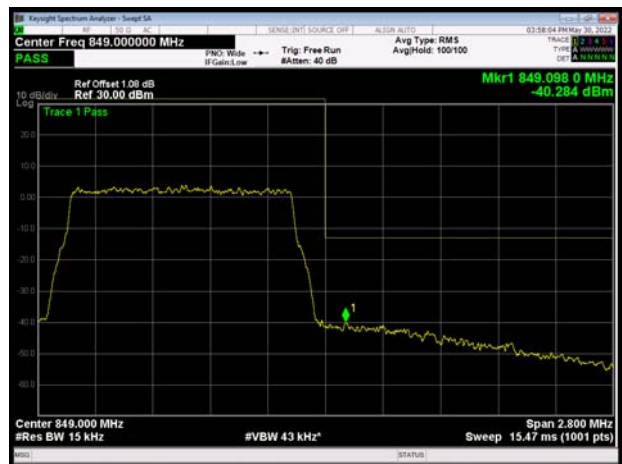



LTE Band 26 16QAM 3MHz CH-Low 1RB

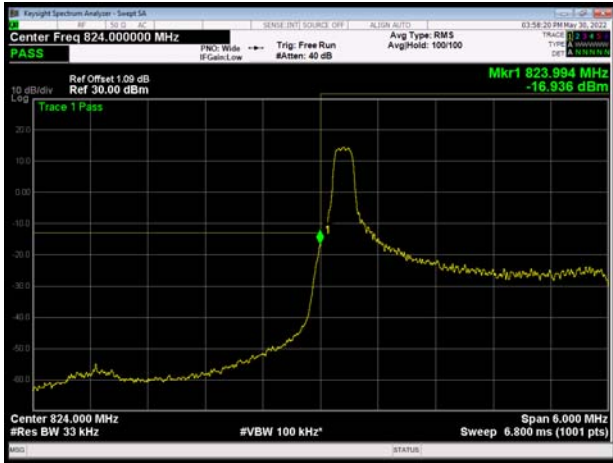

LTE Band 26 16QAM 3MHz CH-High 1RB

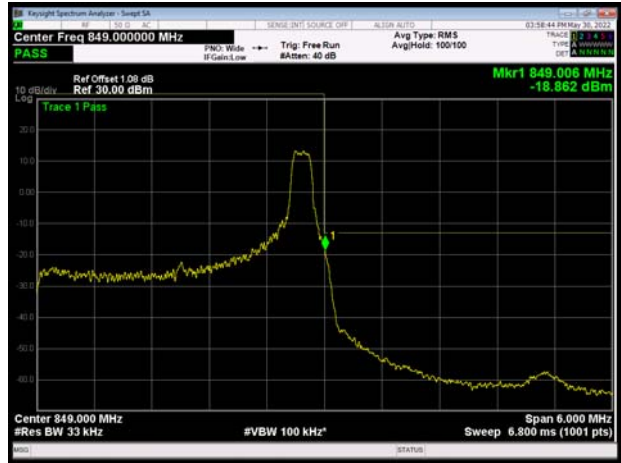

LTE Band 26 16QAM 3MHz CH-Low 100%RB

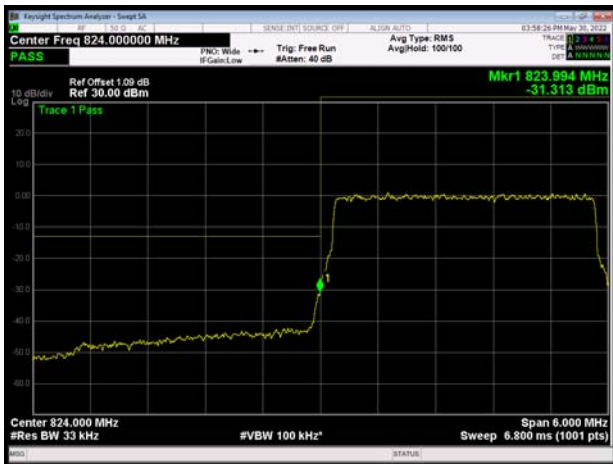

LTE Band 26 16QAM 3MHz CH-High 100%RB

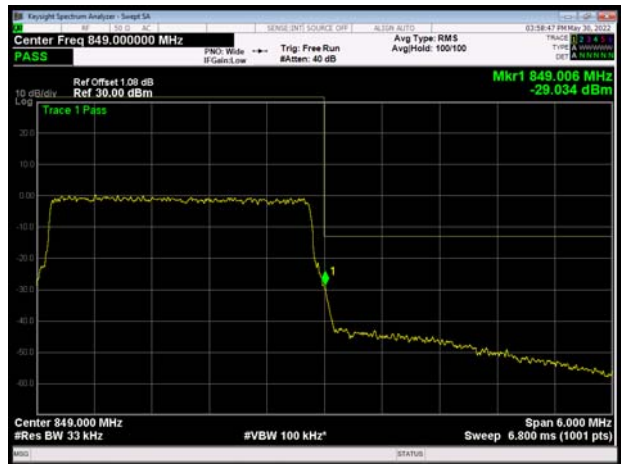

LTE Band 26 16QAM 5MHz CH-Low 1RB

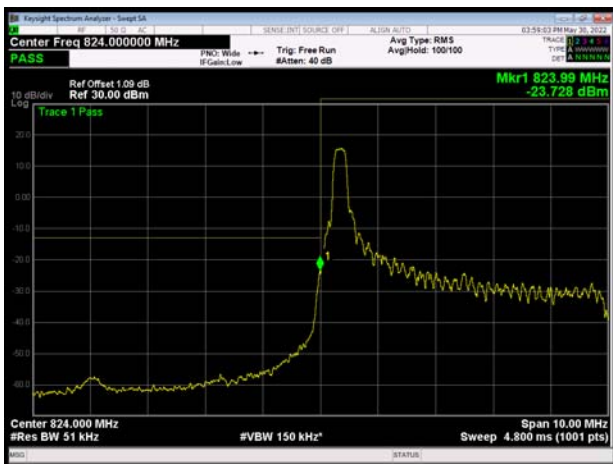

LTE Band 26 16QAM 5MHz CH-High 1RB

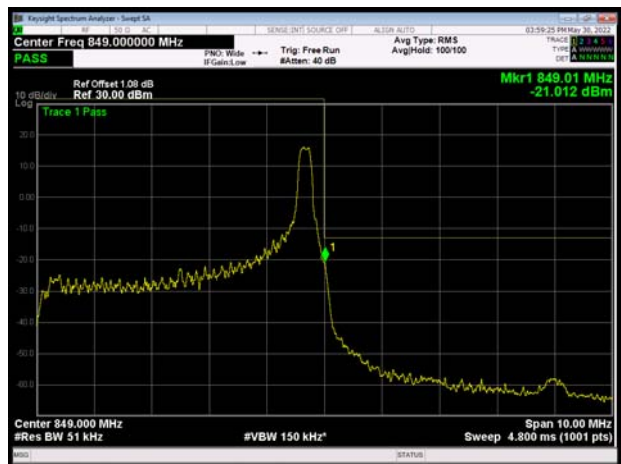



LTE Band 26 16QAM 5MHz CH-Low 100%RB

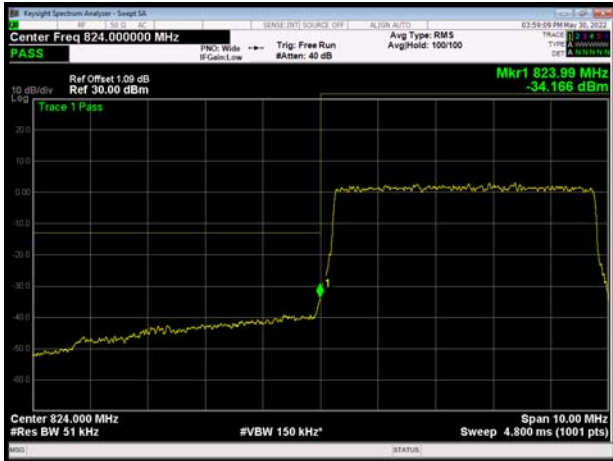

LTE Band 26 16QAM 5MHz CH-High 100%RB



LTE Band 26 16QAM 10MHz CH-Low 1RB

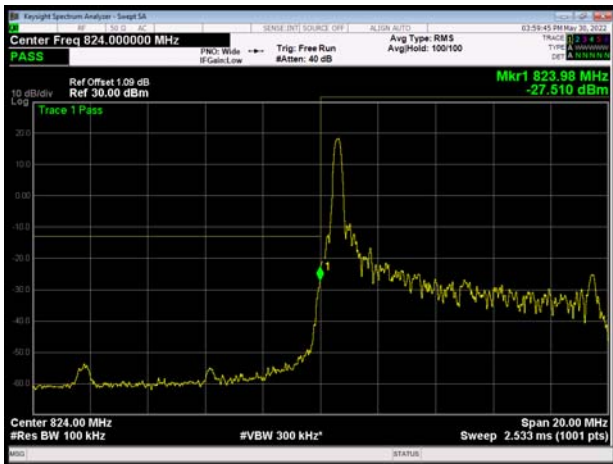

LTE Band 26 16QAM 10MHz CH-High 1RB

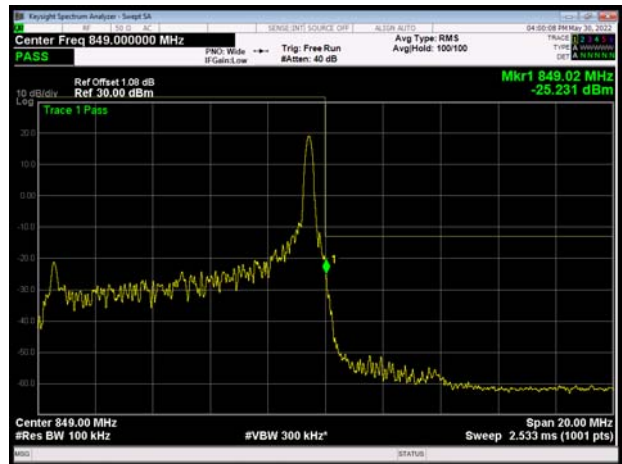

LTE Band 26 16QAM 10MHz CH-Low 100%RB

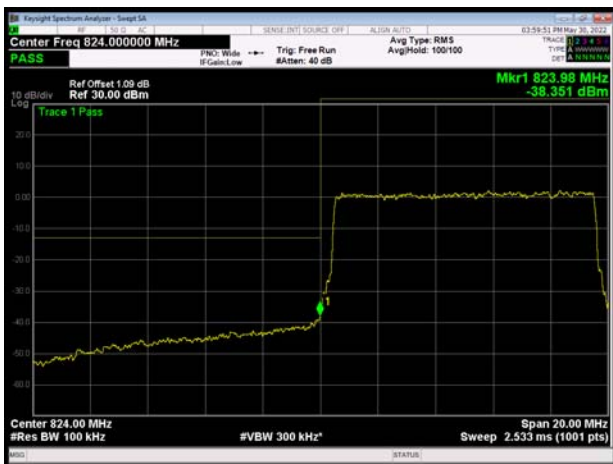

LTE Band 26 16QAM 10MHz CH-High 100%RB





LTE Band 26 16QAM 15MHz CH-Low 1RB

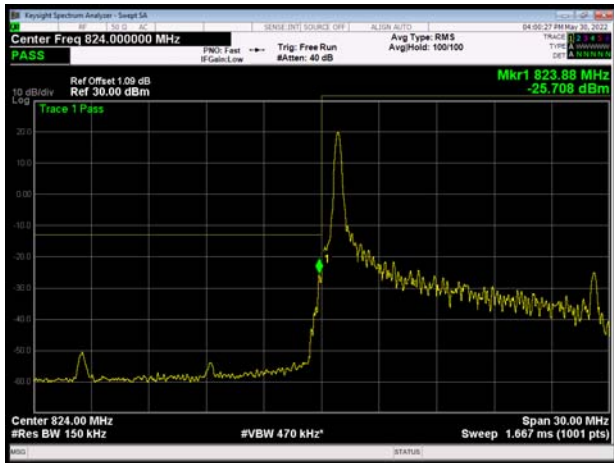

LTE Band 26 16QAM 15MHz CH-High 1RB

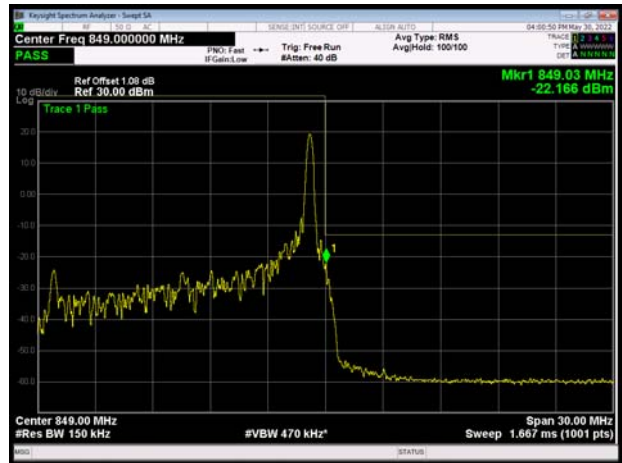

LTE Band 26 16QAM 15MHz CH-Low 100%RB

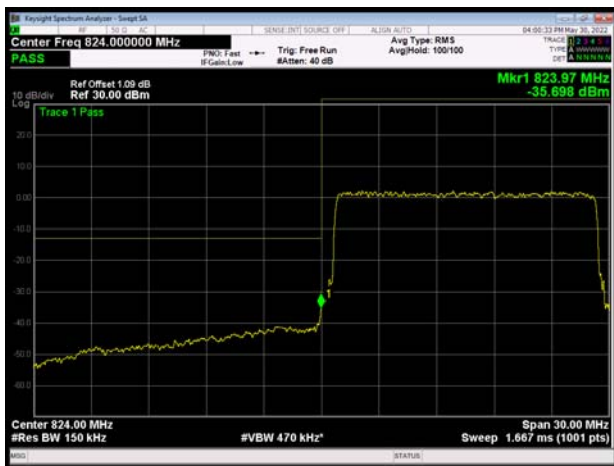

LTE Band 26 16QAM 15MHz CH-High 100%RB

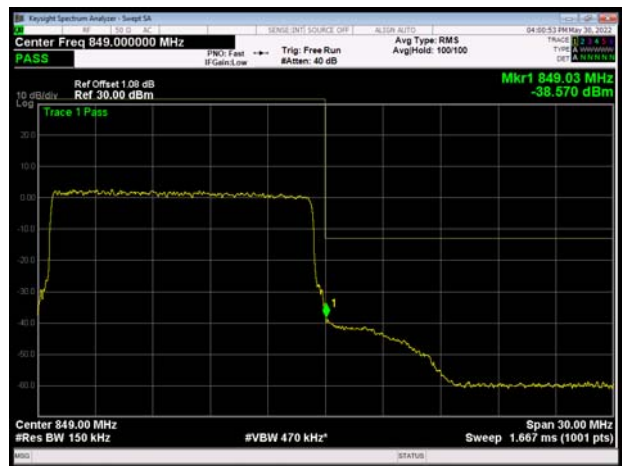

LTE Band 26 64QAM 1.4MHz CH-Low 1RB

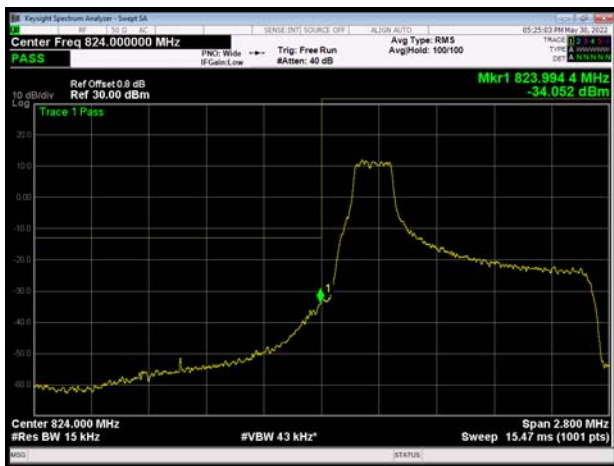

LTE Band 26 64QAM 1.4MHz CH-High 1RB

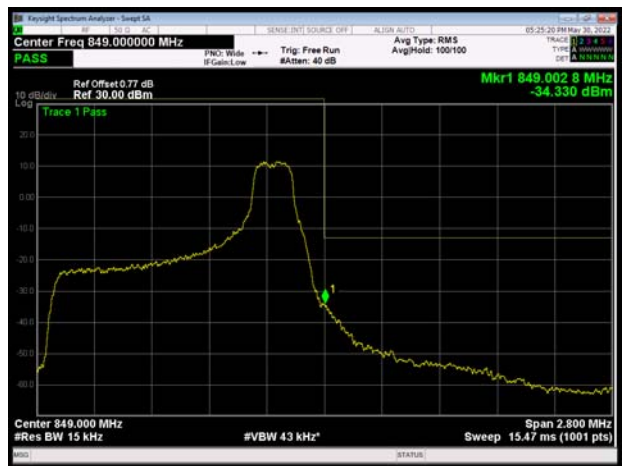

LTE Band 26 64QAM 1.4MHz CH-Low 100%RB

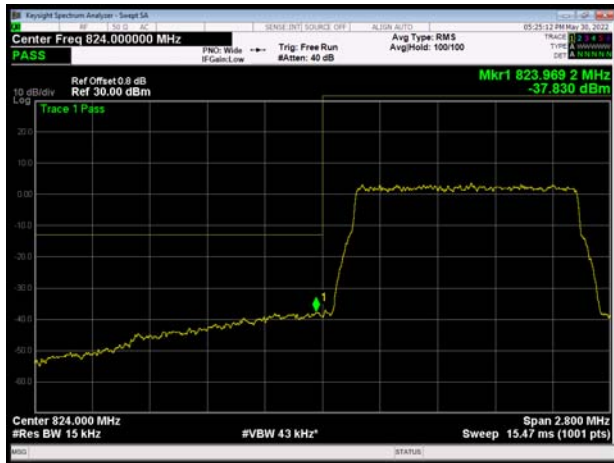

LTE Band 26 64QAM 1.4MHz CH-High 100%RB

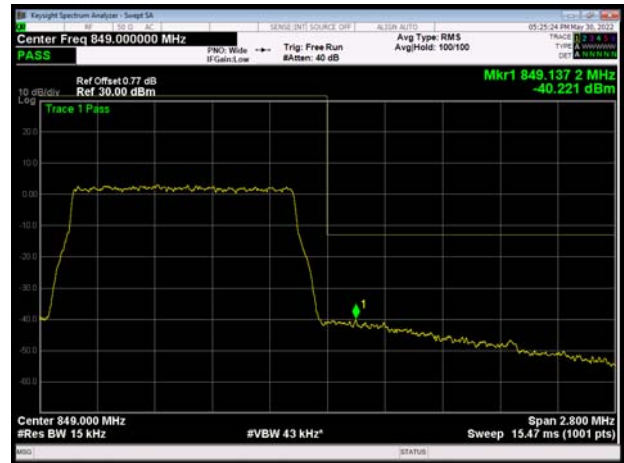

LTE Band 26 64QAM 3MHz CH-Low 1RB

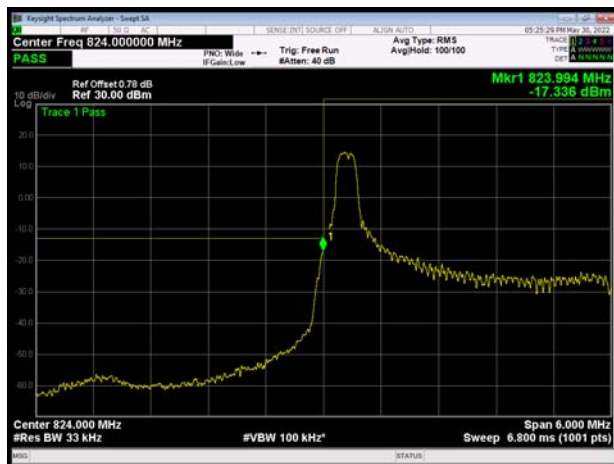

LTE Band 26 64QAM 3MHz CH-High 1RB

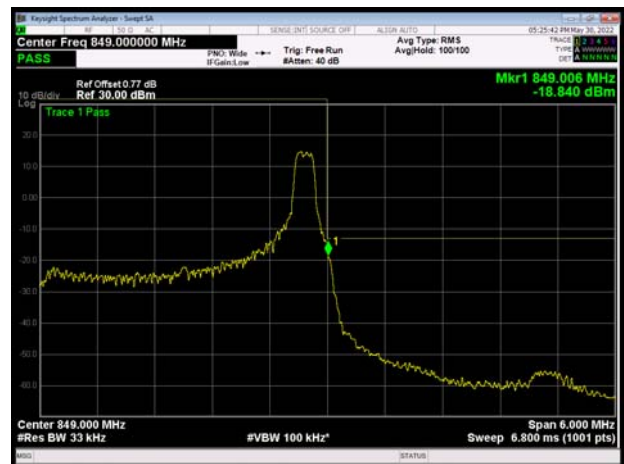

LTE Band 26 64QAM 3MHz CH-Low 100%RB

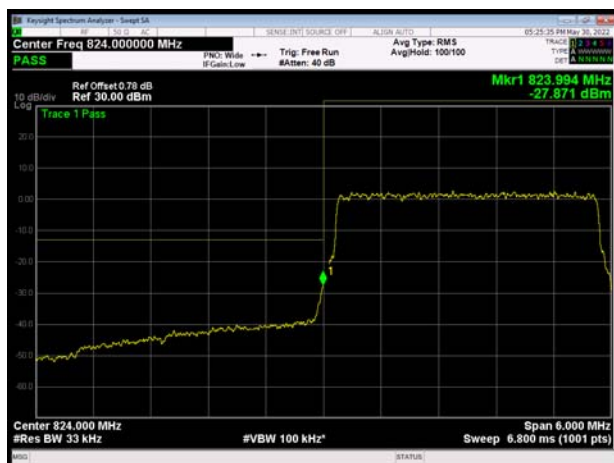

LTE Band 26 64QAM 3MHz CH-High 100%RB

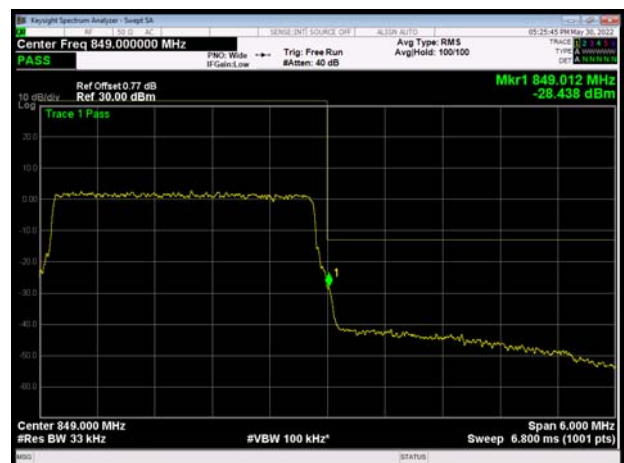

LTE Band 26 64QAM 5MHz CH-Low 1RB

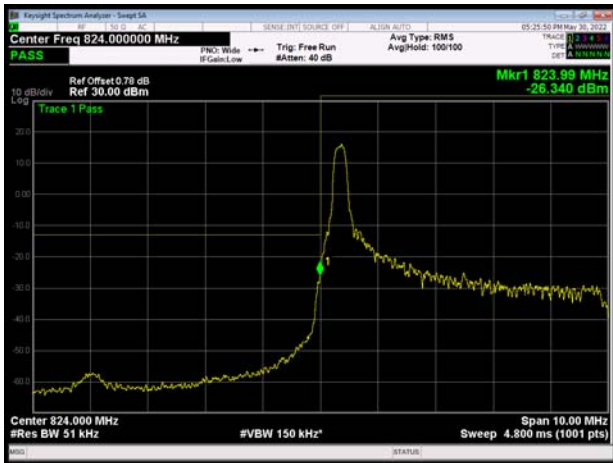

LTE Band 26 64QAM 5MHz CH-High 1RB

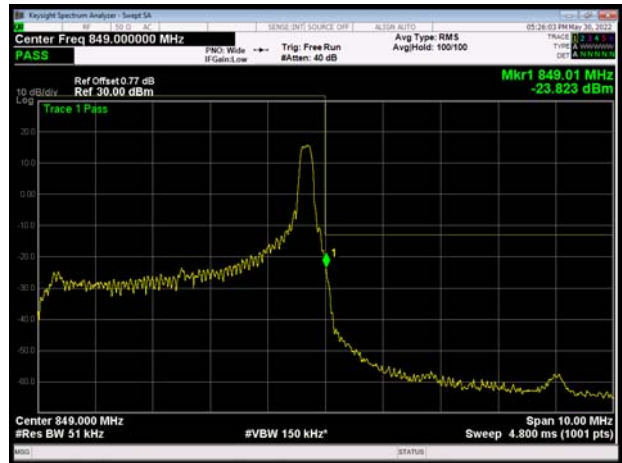

LTE Band 26 64QAM 5MHz CH-Low 100%RB

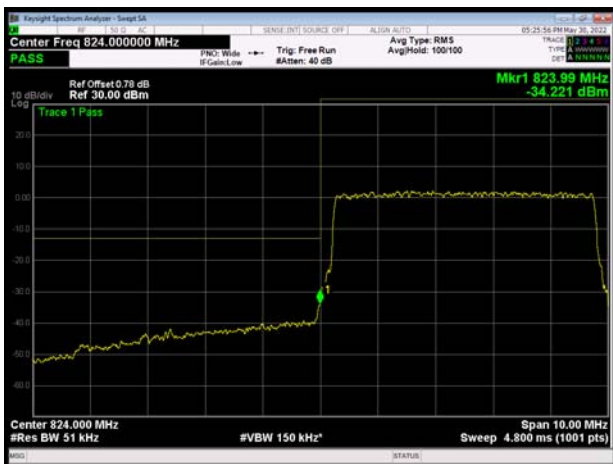

LTE Band 26 64QAM 5MHz CH-High 100%RB

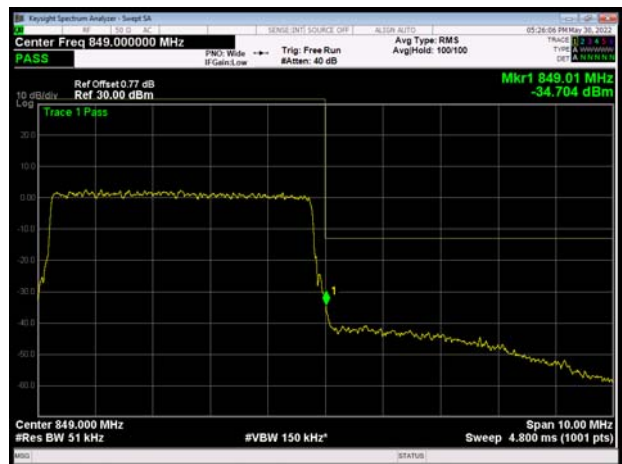

LTE Band 26 64QAM 10MHz CH-Low 1RB

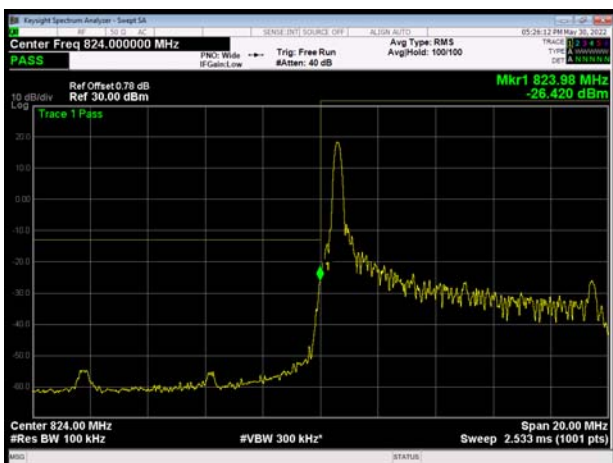

LTE Band 26 64QAM 10MHz CH-High 1RB

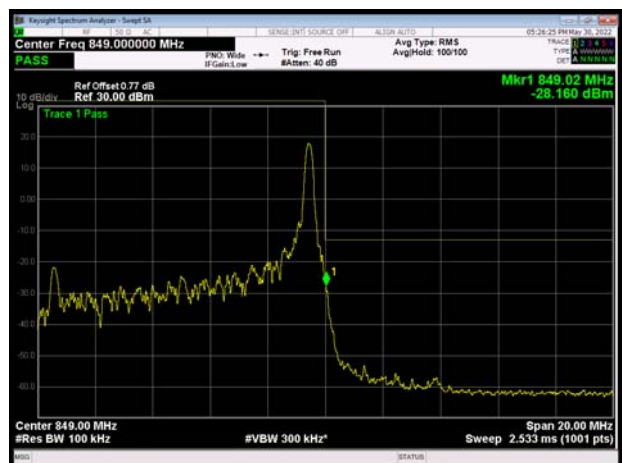



LTE Band 26 64QAM 10MHz CH-Low 100%RB

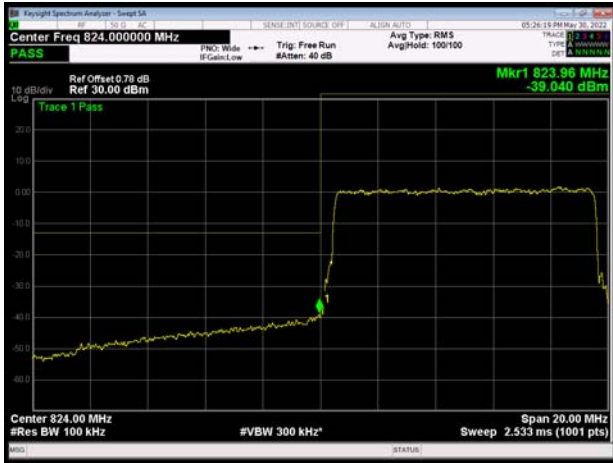

LTE Band 26 64QAM 10MHz CH-High 100%RB



LTE Band 26 64QAM 15MHz CH-Low 1RB

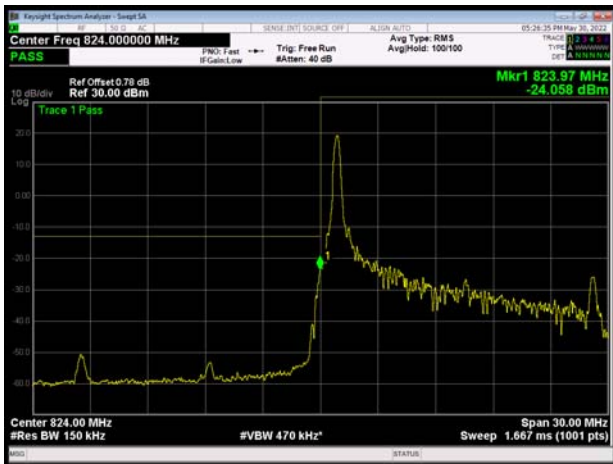

LTE Band 26 64QAM 15MHz CH-High 1RB

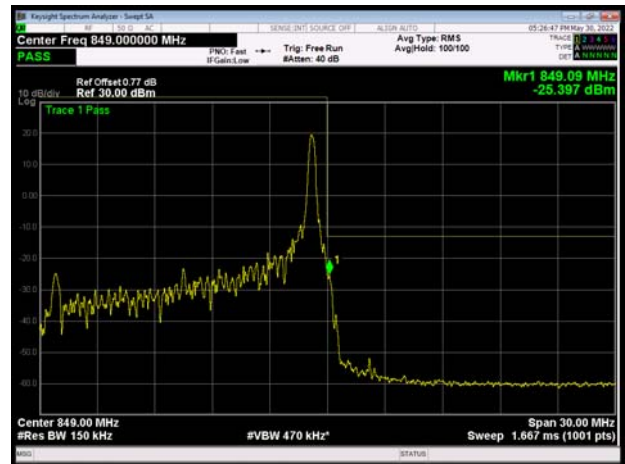

LTE Band 26 64QAM 15MHz CH-Low 100%RB

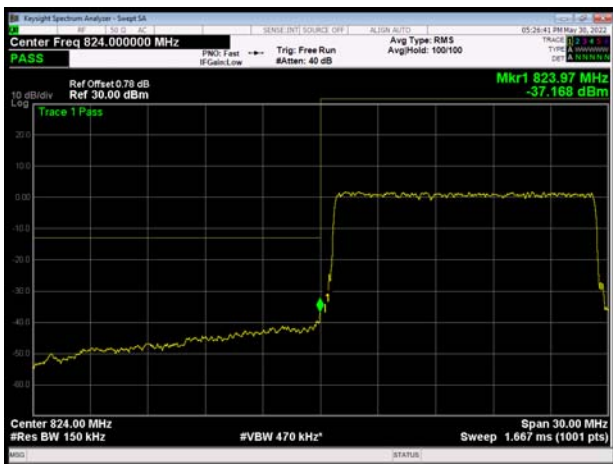

LTE Band 26 64QAM 15MHz CH-High 100%RB



6.4. Peak-to-Average Power Ratio (PAPR)

LTE Band 26								
Modulation	Bandwidth (MHz)	Channel	Frequency (MHz)	Peak (dBm)	Avg (dBm)	PAPR (dB)	Limit (dB)	Conclusion
QPSK	1.4	26797	824.7	26.99	21.35	5.64	≤13	PASS
		26915	836.5	26.95	21.40	5.55	≤13	PASS
		27033	848.3	26.33	20.91	5.42	≤13	PASS
	3	26805	825.5	27.03	21.29	5.74	≤13	PASS
		26915	836.5	26.91	21.41	5.50	≤13	PASS
		27025	847.5	26.65	21.22	5.43	≤13	PASS
	5	26815	826.5	26.71	21.01	5.70	≤13	PASS
		26915	836.5	26.97	21.42	5.55	≤13	PASS
		27015	846.5	26.77	21.37	5.40	≤13	PASS
	10	26840	829	26.71	21.01	5.70	≤13	PASS
		26915	836.5	26.89	21.32	5.57	≤13	PASS
		26990	844	26.44	20.90	5.54	≤13	PASS
	15	26865	831.5	27.33	21.37	5.96	≤13	PASS
		26915	836.5	27.25	21.32	5.93	≤13	PASS
		26965	841.5	27.18	21.39	5.79	≤13	PASS
16QAM	1.4	26797	824.7	26.79	20.44	6.35	≤13	PASS
		26915	836.5	26.81	20.45	6.36	≤13	PASS
		27033	848.3	26.59	20.62	5.97	≤13	PASS
	3	26805	825.5	26.88	20.44	6.44	≤13	PASS
		26915	836.5	26.83	20.44	6.39	≤13	PASS
		27025	847.5	26.46	20.29	6.17	≤13	PASS
	5	26815	826.5	26.77	20.44	6.33	≤13	PASS
		26915	836.5	26.68	20.39	6.29	≤13	PASS
		27015	846.5	26.44	20.24	6.20	≤13	PASS
	10	26840	829	26.35	19.98	6.37	≤13	PASS
		26915	836.5	26.71	20.38	6.33	≤13	PASS
		26990	844	26.56	20.36	6.20	≤13	PASS
	15	26865	831.5	26.90	20.52	6.38	≤13	PASS
		26915	836.5	26.80	20.40	6.40	≤13	PASS
		26965	841.5	26.63	20.33	6.30	≤13	PASS
64QAM	1.4	26797	824.7	26.60	20.21	6.39	≤13	PASS
		26915	836.5	26.48	20.14	6.34	≤13	PASS
		27033	848.3	26.36	20.29	6.07	≤13	PASS
	3	26805	825.5	26.61	20.12	6.49	≤13	PASS



		26915	836.5	26.56	20.17	6.39	≤13	PASS
		27025	847.5	26.18	19.94	6.24	≤13	PASS
	5	26815	826.5	26.55	20.21	6.34	≤13	PASS
		26915	836.5	26.36	20.08	6.28	≤13	PASS
		27015	846.5	26.09	19.87	6.22	≤13	PASS
	10	26840	829	26.05	19.64	6.41	≤13	PASS
		26915	836.5	26.40	20.06	6.34	≤13	PASS
		26990	844	26.28	20.04	6.24	≤13	PASS
	15	26865	831.5	26.62	20.17	6.45	≤13	PASS
		26915	836.5	26.48	20.07	6.41	≤13	PASS
		26965	841.5	26.41	20.09	6.32	≤13	PASS



6.5. Frequency Stability

LTE Band 26								
Condition		Freq.Error (Hz)	Freq.Error (Hz)	Freq.Error (Hz)	Frequency Stability (ppm)	Frequency Stability (ppm)	Frequency Stability (ppm)	Verdict
BANDWIDTH	1.4MHz							
Temperature	Voltage	64QAM	16QAM	QPSK	64QAM	16QAM	QPSK	
Normal (25°C)	Normal	2.70	5.32	4.14	0.00322	0.00636	0.00495	PASS
Extreme (50°C)		7.55	3.29	9.52	0.00903	0.00393	0.01138	PASS
Extreme (40°C)		4.25	9.78	9.51	0.00509	0.01170	0.01136	PASS
Extreme (30°C)		9.57	6.67	15.35	0.01144	0.00798	0.01835	PASS
Extreme (20°C)		5.16	14.68	11.25	0.00616	0.01755	0.01344	PASS
Extreme (10°C)		9.30	15.00	10.79	0.01112	0.01793	0.01290	PASS
Extreme (0°C)		5.37	11.70	2.52	0.00642	0.01399	0.00301	PASS
Extreme (-10°C)		6.28	10.72	4.08	0.00751	0.01282	0.00487	PASS
Extreme (-20°C)		15.00	16.84	2.58	0.01793	0.02013	0.00308	PASS
Extreme (-30°C)		7.33	11.44	3.76	0.00877	0.01368	0.00449	PASS
25°C	LV	17.55	5.67	7.26	0.02098	0.00678	0.00867	PASS
	HV	11.44	13.09	16.30	0.01367	0.01565	0.01949	PASS
Condition		Freq.Error (Hz)	Freq.Error (Hz)	Freq.Error (Hz)	Frequency Stability (ppm)	Frequency Stability (ppm)	Frequency Stability (ppm)	Verdict
BANDWIDTH	3MHz							
Temperature	Voltage	64QAM	16QAM	QPSK	64QAM	16QAM	QPSK	
Normal (25°C)	Normal	13.49	13.35	13.94	0.01612	0.01596	0.01666	PASS
Extreme (50°C)		6.78	17.28	3.77	0.00811	0.02065	0.00451	PASS
Extreme (40°C)		5.83	15.11	12.56	0.00697	0.01806	0.01501	PASS
Extreme (30°C)		16.56	2.44	9.07	0.01979	0.00292	0.01084	PASS
Extreme (20°C)		10.85	12.21	1.39	0.01297	0.01460	0.00166	PASS
Extreme (10°C)		5.48	6.78	17.93	0.00656	0.00811	0.02144	PASS
Extreme (0°C)		15.19	15.94	17.02	0.01815	0.01906	0.02035	PASS
Extreme (-10°C)		16.73	14.97	2.64	0.02001	0.01790	0.00316	PASS
Extreme (-20°C)		7.36	6.24	7.52	0.00880	0.00746	0.00899	PASS
Extreme (-30°C)		11.73	1.49	7.81	0.01402	0.00178	0.00934	PASS
25°C	LV	15.29	8.23	2.24	0.01827	0.00984	0.00267	PASS
	HV	9.54	1.98	10.89	0.01140	0.00237	0.01302	PASS
Condition		Freq.Error (Hz)	Freq.Error (Hz)	Freq.Error (Hz)	Frequency Stability (ppm)	Frequency Stability (ppm)	Frequency Stability (ppm)	Verdict
BANDWIDTH	5MHz							
Temperature	Voltage	64QAM	16QAM	QPSK	64QAM	16QAM	QPSK	
Normal (25°C)	Normal	2.15	11.27	9.47	0.00258	0.01347	0.01132	PASS
Extreme (50°C)		12.33	6.72	14.20	0.01475	0.00803	0.01697	PASS
Extreme (40°C)		1.77	4.76	3.40	0.00212	0.00570	0.00407	PASS



Extreme (30°C)		8.29	12.96	7.62	0.00991	0.01549	0.00911	PASS
Extreme (20°C)		10.31	11.83	2.66	0.01232	0.01414	0.00318	PASS
Extreme (10°C)		16.14	3.49	6.54	0.01929	0.00418	0.00782	PASS
Extreme (0°C)		11.06	7.13	6.53	0.01322	0.00853	0.00781	PASS
Extreme (-10°C)		6.36	14.43	13.87	0.00760	0.01725	0.01658	PASS
Extreme (-20°C)		17.53	7.17	8.46	0.02096	0.00857	0.01011	PASS
Extreme (-30°C)		15.98	4.87	3.33	0.01910	0.00582	0.00398	PASS
25°C	LV	9.13	4.89	2.25	0.01091	0.00585	0.00269	PASS
	HV	11.20	7.11	4.99	0.01338	0.00850	0.00597	PASS
Condition		Freq.Error (Hz)	Freq.Error (Hz)	Freq.Error (Hz)	Frequency Stability (ppm)	Frequency Stability (ppm)	Frequency Stability (ppm)	Verdict
BANDWIDTH	10MHz							
Temperature	Voltage	64QAM	16QAM	QPSK	64QAM	16QAM	QPSK	
Normal (25°C)	Normal	4.04	3.50	16.11	0.00483	0.00419	0.01926	PASS
Extreme (50°C)		9.33	2.04	10.97	0.01115	0.00244	0.01311	PASS
Extreme (40°C)		17.97	8.19	17.11	0.02148	0.00979	0.02045	PASS
Extreme (30°C)		1.68	4.06	1.62	0.00201	0.00485	0.00194	PASS
Extreme (20°C)		16.19	6.59	4.66	0.01935	0.00788	0.00557	PASS
Extreme (10°C)		7.53	4.13	12.28	0.00900	0.00493	0.01468	PASS
Extreme (0°C)		13.01	10.01	15.46	0.01555	0.01196	0.01848	PASS
Extreme (-10°C)		17.93	8.77	2.51	0.02143	0.01049	0.00300	PASS
Extreme (-20°C)		3.42	7.95	12.69	0.00409	0.00950	0.01517	PASS
Extreme (-30°C)		6.57	1.58	12.88	0.00786	0.00188	0.01540	PASS
25°C	LV	11.92	8.05	13.85	0.01425	0.00963	0.01655	PASS
	HV	3.46	2.99	10.29	0.00414	0.00357	0.01230	PASS
Condition		Freq.Error (Hz)	Freq.Error (Hz)	Freq.Error (Hz)	Frequency Stability (ppm)	Frequency Stability (ppm)	Frequency Stability (ppm)	Verdict
BANDWIDTH	15MHz							
Temperature	Voltage	64QAM	16QAM	QPSK	64QAM	16QAM	QPSK	
Normal (25°C)	Normal	10.88	14.43	5.31	0.01300	0.01724	0.00634	PASS
Extreme (50°C)		5.58	14.21	1.15	0.00668	0.01699	0.00137	PASS
Extreme (40°C)		6.71	6.47	3.85	0.00802	0.00773	0.00460	PASS
Extreme (30°C)		5.59	5.13	17.88	0.00668	0.00613	0.02138	PASS
Extreme (20°C)		17.46	13.49	4.42	0.02088	0.01613	0.00528	PASS
Extreme (10°C)		1.96	12.72	4.37	0.00234	0.01521	0.00522	PASS
Extreme (0°C)		3.73	13.16	15.29	0.00445	0.01574	0.01828	PASS
Extreme (-10°C)		14.12	12.71	10.76	0.01688	0.01520	0.01287	PASS
Extreme (-20°C)		9.49	13.86	3.13	0.01134	0.01657	0.00374	PASS
Extreme (-30°C)		11.90	14.22	8.96	0.01423	0.01700	0.01071	PASS
25°C	LV	2.86	8.62	6.02	0.00342	0.01031	0.00719	PASS
	HV	13.13	9.08	3.53	0.01570	0.01086	0.00422	PASS

6.6. Spurious Emissions at Antenna Terminals

Sweep the whole frequency band through the range from 9kHz to the 10th harmonic of the carrier, the emissions more than 20 dB below the limit are not reported.

The signal beyond the limit is carrier.

LTE Band 26 1.4MHz CH-Low 9kHz~10GHz

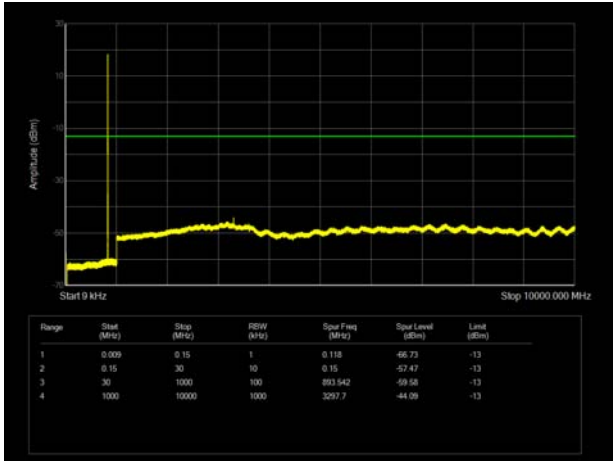

LTE Band 26 3MHz CH-Low 9kHz~10GHz

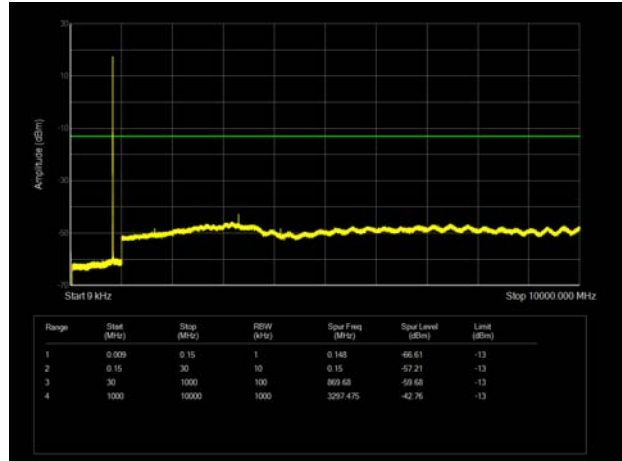

LTE Band 26 1.4MHz CH-Middle 9kHz~10GHz

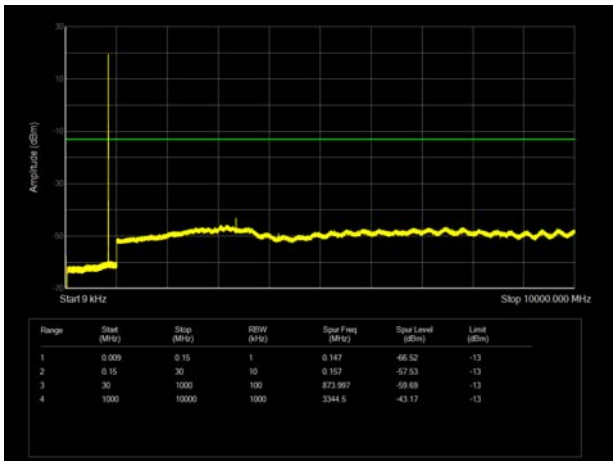

LTE Band 26 3MHz CH-Middle 9kHz~10GHz

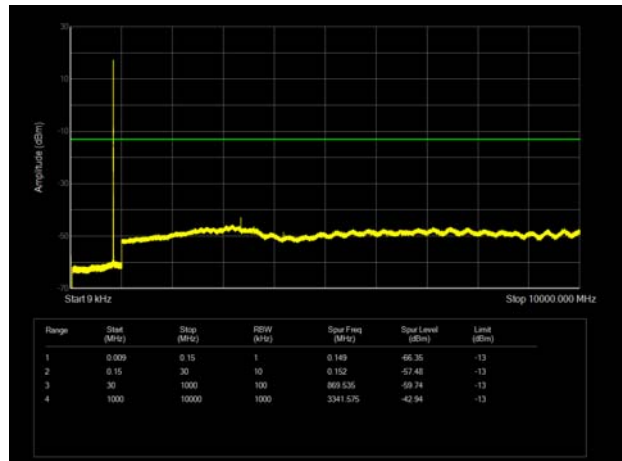

LTE Band 26 1.4MHz CH-High 9kHz~10GHz

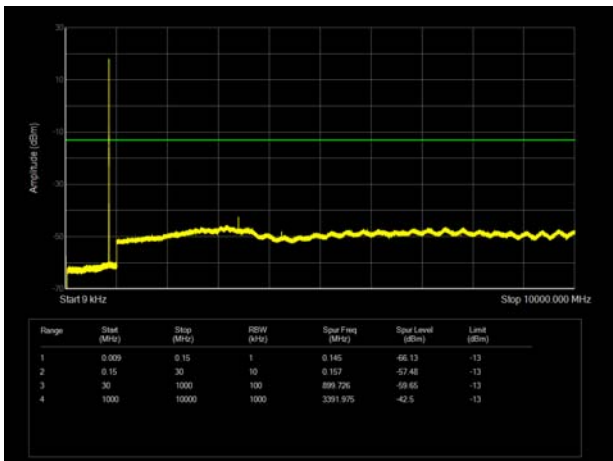

LTE Band 26 3MHz CH-High 9kHz~10GHz

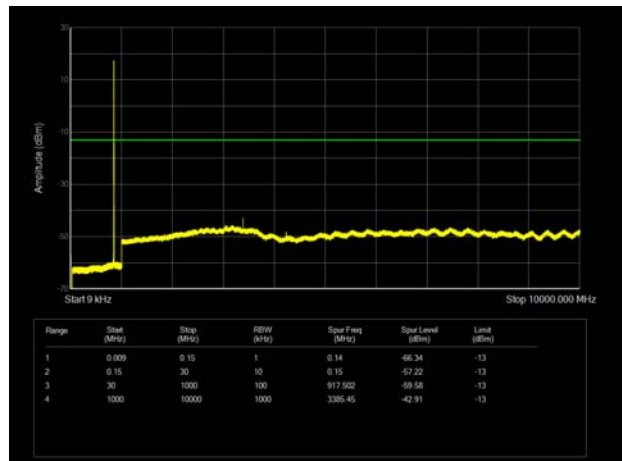

LTE Band 26 5MHz CH-Low 9kHz~10GHz

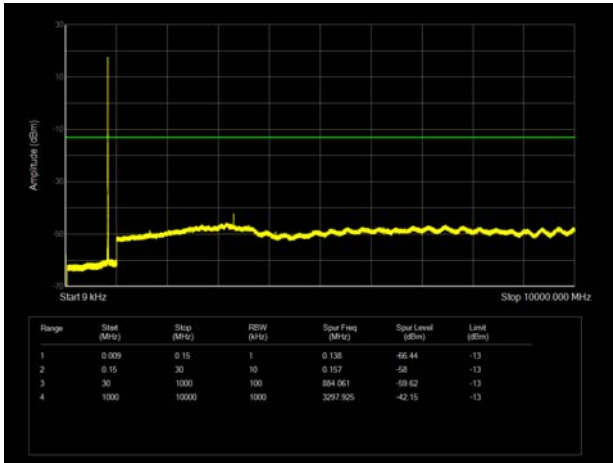

LTE Band 26 10MHz CH-Low 9kHz~10GHz

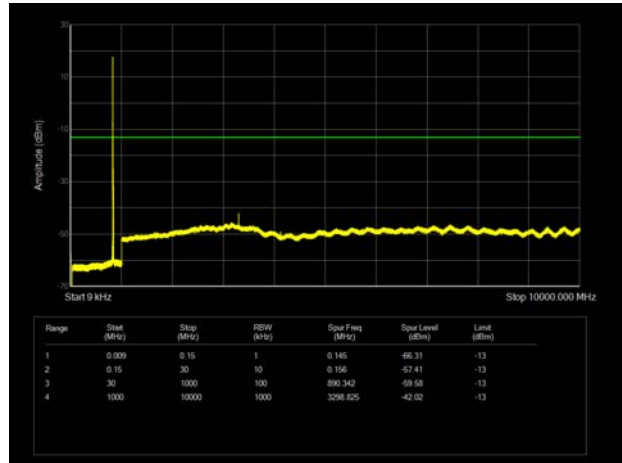

LTE Band 26 5MHz CH-Middle 9kHz~10GHz

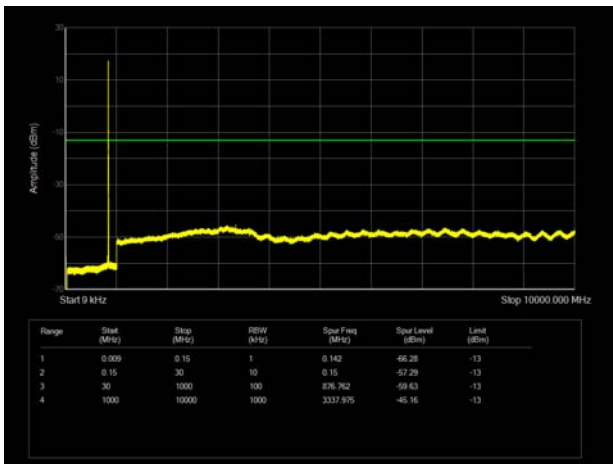

LTE Band 26 10MHz CH-Middle 9kHz~10GHz

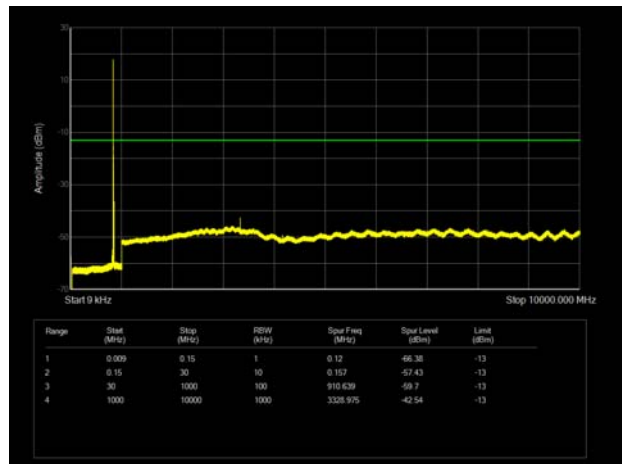

LTE Band 26 5MHz CH-High 9kHz~10GHz

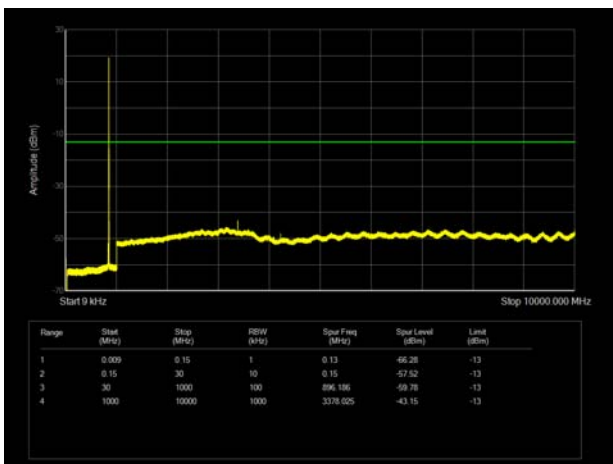

LTE Band 26 10MHz CH-High 9kHz~10GHz

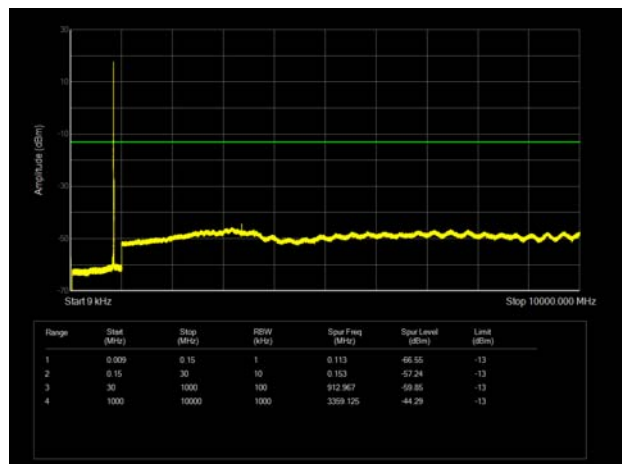

LTE Band 26 15MHz CH-Low 9kHz~10GHz

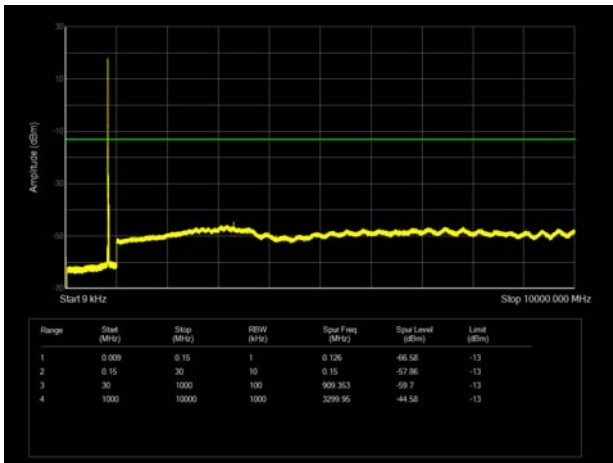

LTE Band 26 15MHz CH-Middle 9kHz~10GHz

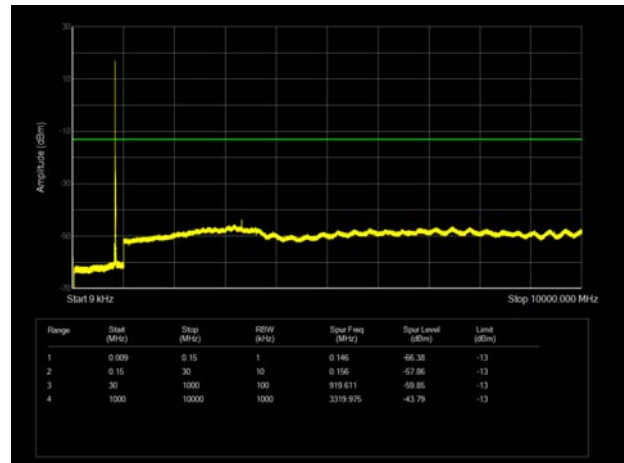

LTE Band 26 15MHz CH-High 9kHz~10GHz

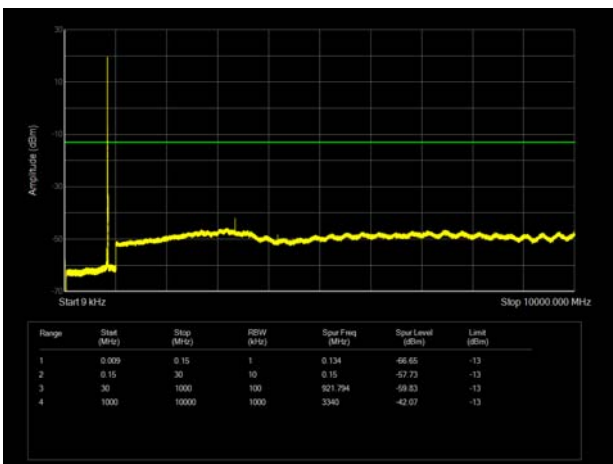

6.7. Radiates Spurious Emission

Sweep the whole frequency band through the range from 9kHz to the 10th harmonic of the carrier, the emissions below the noise floor will not be recorded in the report.

LTE Band 26 1.4MHz CH-Middle

Harmonic	Frequency (MHz)	SG (dBm)	Cable Loss (dB)	Gain (dBi)	Antenna Polarization	ERP Level (dBm)	Limit (dBm)	Margin (dB)	Azimuth (deg)
2	1671.60	-62.72	1.70	8.70	Horizontal	-57.87	-13.00	44.87	135
3	2507.40	-53.33	2.30	12.00	Horizontal	-45.78	-13.00	32.78	0
4	3343.20	-57.76	2.70	12.70	Horizontal	-49.91	-13.00	36.91	90
5	4179.00	-60.59	3.00	12.50	Horizontal	-53.24	-13.00	40.24	270
6	5014.80	-61.27	3.40	12.50	Horizontal	-54.32	-13.00	41.32	45
7	5850.60	-63.20	3.40	12.80	Horizontal	-55.95	-13.00	42.95	315
8	6686.40	-57.94	4.10	11.50	Horizontal	-52.69	-13.00	39.69	270
9	7522.20	-53.00	4.20	12.20	Horizontal	-47.15	-13.00	34.15	90
10	8358.00	-52.72	4.30	12.50	Horizontal	-46.67	-13.00	33.67	0

Note: 1. The other Spurious RF Radiated emissions level is no more than noise floor.
2. The worst emission was found in the antenna is Horizontal position.

LTE Band 26 5MHz CH-Middle

Harmonic	Frequency (MHz)	SG (dBm)	Cable Loss (dB)	Gain (dBi)	Antenna Polarization	ERP Level (dBm)	Limit (dBm)	Margin (dB)	Azimuth (deg)
2	1668.50	-61.54	1.70	8.70	Horizontal	-56.69	-13.00	43.69	315
3	2502.00	-51.93	2.30	12.00	Horizontal	-44.38	-13.00	31.38	180
4	3336.00	-57.43	2.70	12.70	Horizontal	-49.58	-13.00	36.58	225
5	4170.00	-60.73	3.00	12.50	Horizontal	-53.38	-13.00	40.38	0
6	5004.00	-60.78	3.40	12.50	Horizontal	-53.83	-13.00	40.83	180
7	5838.00	-63.79	3.40	12.80	Horizontal	-56.54	-13.00	43.54	45
8	6672.00	-57.94	4.10	11.50	Horizontal	-52.69	-13.00	39.69	135
9	7506.00	-49.84	4.20	12.20	Horizontal	-43.99	-13.00	30.99	225
10	8340.00	-50.83	4.30	12.50	Horizontal	-44.78	-13.00	31.78	45

Note: 1. The other Spurious RF Radiated emissions level is no more than noise floor.
2. The worst emission was found in the antenna is Horizontal position.



LTE Band 26 15MHz CH-Middle

Harmonic	Frequency (MHz)	SG (dBm)	Cable Loss (dB)	Gain (dBi)	Antenna Polarization	ERP Level (dBm)	Limit (dBm)	Margin (dB)	Azimuth (deg)
2	1658.00	-65.45	1.70	8.70	Horizontal	-60.60	-13.00	47.60	225
3	2487.00	-58.48	2.30	12.00	Horizontal	-50.93	-13.00	37.93	135
4	3316.00	-56.31	2.70	12.70	Horizontal	-48.46	-13.00	35.46	135
5	4145.00	-60.64	3.00	12.50	Horizontal	-53.29	-13.00	40.29	225
6	4974.00	-62.31	3.40	12.50	Horizontal	-55.36	-13.00	42.36	45
7	5803.00	-62.81	3.40	12.80	Horizontal	-55.56	-13.00	42.56	315
8	6632.00	-57.47	4.10	11.50	Horizontal	-52.22	-13.00	39.22	180
9	7461.00	-45.80	4.20	12.20	Horizontal	-39.95	-13.00	26.95	135
10	8290.00	-49.58	4.30	12.50	Horizontal	-43.53	-13.00	30.53	45

Note: 1. The other Spurious RF Radiated emissions level is no more than noise floor.

2. The worst emission was found in the antenna is Horizontal position.

7. Main Test Instruments

Name	Manufacturer	Type	Serial Number	Calibration Date	Expiration Date
Climate Chamber	ESPEC	SU-242	93000506	2021-12-12	2022-12-11
Universal Radio Communication Tester	R&S	CMW500	150415	2022-05-14	2023-05-13
Spectrum Analyzer	Keysight	N9020A	MY50510203	2021-12-12	2022-12-11
Universal Radio Communication Tester	Agilent	E5515C	GB44400275	2021-12-12	2022-12-11
Spectrum Analyzer	R&S	FSV3030	101411	2021-12-12	2022-12-11
Spectrum Analyzer	R&S	FSV40	101297	2021-12-12	2022-12-11
Loop antenna	SCHWARZBECK	FMZB1519	1519-047	2020-04-02	2023-04-01
TRILOG Broadband Antenna	Schwarzbeck	VULB 9163	01111	2019-09-12	2022-09-11
Horn Antenna	Schwarzbeck	BBHA 9120D	1594	2020-12-17	2023-12-16
Software	R&S	EMC32	10.35.10	/	/

*****END OF REPORT *****



ANNEX A: The EUT Appearance

The EUT Appearance is submitted separately.



ANNEX B: Test Setup Photos

The Test Setup Photos is submitted separately.