

Instructions for use

Thank you very much for purchasing our electronic scale product. Please read this instruction manual carefully before use. Correct use and maintenance will extend the service life of the product.

Scale Description

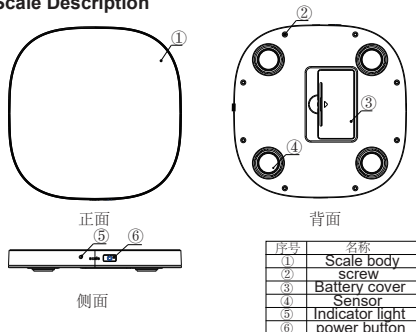

Display Description

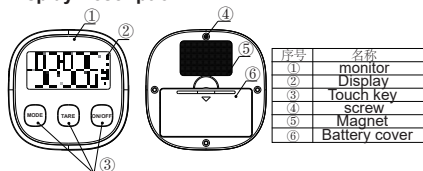

Display Magnet Instructions

1. Tear off the anti-sticking paper on the surface of the metal magnet sheet
2. Use the strong magnet on the monitor to suck the metal magnet sheet to the position corresponding to the strong magnet (for fixing the size), and then press the monitor to fix it on the background wall.

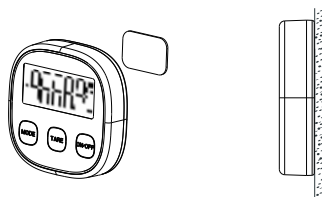

Specs and Features

1. Specifications/Accuracy: 5000g/1g, 10000g/1g, 15000g/1g
2. button: ("MODE" Unit key) ("TARE" Clear key) ("ON/OFF" Power button)
3. Unit conversion: g / lb / oz / lb:oz / fl.oz / ml / milk ml / kg
4. Operating Voltage: 3V
5. Operating temperature: 10 to 30 degrees Celsius

Wireless connection:

1. When the display and the scale are powered on at the same time, they will automatically connect.
2. The wireless connection will be faster if the scale is powered on first and then the display

power supply:

This product adopts an ultra-low power consumption environmentally friendly design and uses four No. 7 batteries. After purchasing this product, please remove the insulating film of the battery and install the battery before using the product.

Scale Status Description:

Place the electronic scale on a horizontal table, long press the power button on the scale to turn it on, and long press the power button to turn it off.

Note:

1. If there is no operation or connection for 100 seconds, the scale will automatically shut down.
2. When the battery is too low, the buzzer on the scale will sound continuously, indicating that the battery of the scale is too low. Please replace the battery in time.
3. The green light is always on, indicating that the scale is in working state

Display status description:

Place the monitor on a horizontal desktop, lightly press the power button " ON/OFF " to turn on the monitor, and after turning on, the display " — " will flash in a loop (this state is searching for devices). After connecting to the device, the display "[ON]" indicates successful connection, and "0 " will be displayed.

Note:

1. The light will automatically turn off if there is no operation for 10 seconds, and will automatically turn on when the weight or value changes
2. The light will automatically turn off if there is no operation or connection for 100 seconds.

Unit conversion:

When the machine is turned on, each time you press the "MODE" button, a weighing unit will be converted. Please select the weight unit you need.

Note: This product has multiple units for conversion

Tare and zero:

Place the container on the weighing pan, press the "Reset" button, and after the display returns to zero, place the items to be weighed into the container. The weight displayed at this time is the weight of the items (the weight of the container is not included).

General Care and Maintenance

1. This instrument is a precision instrument. Please do not drop it or subject it to strong impact to avoid product failure.
2. When storing the product, do not place any objects on the scale platform or load other items, otherwise it will cause malfunction.
3. Avoid exposure to extreme heat or cold. Always allow your scale to acclimate to normal room temperature before use.
4. Place the scale in a clean and dry environment. Dust, dirt, moisture, vibration, or proximity to other electronic devices may adversely affect the accuracy and reliability of the scale.
5. Handle with care and gently place all items to be weighed on top of the scale pan. Although the electronic scale is designed to be very durable, rough use should be avoided as this may permanently damage the internal components.

Troubleshooting:

The main reasons for inaccurate weighing and malfunction are: low battery, incorrect calibration, weighing items exceeding the maximum range of the product or not operating on a level surface, etc.

- 【 — 】 Searching for devices
- 【 Lo 】 It indicates that the battery power is low, please replace the battery in time.
- 【 0_Ld 】 If overweight, remove the overweight items immediately.
- 【 UNST 】 If the product is unstable, windy, vibrating, or not level, please place it on a hard surface in a windless, level, and undisturbed environment.
- 【 🔊 】 If the buzzer on the scale beeps continuously, it means the battery power of the scale is too low. Please replace the battery in time.

Precautions:

Pairing is required when changing monitors
After powering on and zeroing, hold the "ON/OFF" and press the "TARE" 3 times at the same time. The will show PASS, indicating that the pairing is successful.

"If you have any questions about this product, please feel free to contact us."



FCC Warning:

This equipment has been tested and found to comply with the limits for a Class B digital device, pursuant to part 15 of the FCC Rules. These limits are designed to provide reasonable protection against harmful interference in a residential installation. This equipment generates, uses and can radiate radio frequency energy and, if not installed and used in accordance with the instructions, may cause harmful interference to radio communications. However, there is no guarantee that interference will not occur in a particular installation. If this equipment does cause harmful interference to radio or television reception, which can be determined by turning the equipment off and on, the user is encouraged to try to correct the interference by one or more of the following measures:

- Reorient or relocate the receiving antenna.
- Increase the separation between the equipment and receiver.
- Connect the equipment into an outlet on a circuit different from that to which the receiver is connected.
- Consult the dealer or an experienced radio/TV technician for help.

Caution: Any changes or modifications to this device not explicitly approved by manufacturer could void your authority to operate this equipment.

This device complies with part 15 of the FCC Rules. Operation is subject to the following two conditions:

(1) This device may not cause harmful interference, and (2) this device must accept any interference received, including interference that may cause undesired operation.

This equipment complies with FCC radiation exposure limits set forth for an uncontrolled environment. This equipment should be installed and operated with minimum distance 0cm between the radiator and your body.