

## TEST REPORT

**Report No.: 24051012HKG-001R1**

Twelve South, LLC

Application For Certification  
(Original Grant)

**FCC ID: 2AREB-HR2D**

Wireless Power Transfer Device - Transmitter

**Prepared and Checked by:**

**Approved by:**

Signed on File

Leung Chun Ning, Peter  
Assistant Engineer

---

Wong Cheuk Ho, Herbert

Assistant Manager

Date: June 24, 2024

---

Intertek's standard Terms and Conditions can be obtained at our website <http://www.intertek.com/terms/>.

This test report only allows to be revised within the retention period unless further standard or the requirement was noticed.

This report is for the exclusive use of Intertek's Client and is provided pursuant to the agreement between Intertek and its Client. Intertek's responsibility and liability are limited to the terms and conditions of the agreement. Intertek assumes no liability to any party, other than to the Client in accordance with the agreement, for any loss, expense or damage occasioned by the use of this report. Only the Client is authorized to permit copying or distribution of this report and then only in its entirety. Any use of the Intertek name or one of its marks for the sale or advertisement of the tested material, product or service must first be approved in writing by Intertek. The observations and test results in this report are relevant only to the sample tested. This report by itself does not imply that the material, product, or service is or has ever been under an Intertek certification program.

© 2017 Intertek

## TEST REPORT

### GENERAL INFORMATION

<b>Grantee:</b>	Twelve South, LLC
<b>Grantee Address:</b>	1503 KING ST STE201 Charleston, SC29405, USA.
<b>Contact Person:</b>	Kelly Witte
<b>Tel:</b>	+1215-378-4436
<b>E-mail:</b>	kelly@twelivesouth.com
<b>Manufacturer:</b>	Twelve South, LLC
<b>Manufacturer Address:</b>	1503 KING ST STE201 Charleston, SC29405, USA.
<b>Brand Name:</b>	 twelivesouth
<b>Model:</b>	HR2D
<b>SKU Number:</b>	TS-24210, TS-24211, TS-24212, TS-24213, TS-24214, TS-24215, TS-24216, TS-24217, TS-24218, TS-24219, TS-24220
<b>Type of EUT:</b>	Wireless Power Transfer Device - Transmitter
<b>Description of EUT:</b>	HiRise 2 Deluxe
<b>Serial Number:</b>	Not Labelled
<b>FCC ID:</b>	2AREB-HR2D
<b>Date of Sample Submitted:</b>	June 17, 2024
<b>Date of Test:</b>	June 17, 2024 to June 19, 2024
<b>Report No.:</b>	24051012HKG-001R1
<b>Report Date:</b>	June 24, 2024
<b>Environmental Conditions:</b>	Temperature: +10 to 40°C Humidity: 10 to 90%
<b>Conclusion:</b>	Test was conducted by client submitted sample. The submitted sample as received complied with the 47 CFR Part 15 Certification.

### AMENDMENT HISTORY

Report No.	Issued Date	Content
24051012HKG-001	June 24, 2024	Original Report
24051012HKG-001R1	September 03, 2024	Revised product description on section 1.1 "earpod charge pad is 5W"

## TEST REPORT

### SUMMARY OF TEST RESULT

Test Specification	Reference	Results
Transmitter Power Line Conducted Emissions	15.207	Complied
Radiated Emission Radiated Emission on the Bandedge	15.209	Complied
Radiated Emission in Restricted Bands	15.205	Complied

The equipment under test is found to be complying with the following standards:  
FCC Part 15, October 1, 2022 Edition

- Note:
1. The EUT uses a permanently attached antenna which, in accordance to section 15.203, is considered sufficient to comply with the pervisions of this section.
  2. Pursuant to FCC part 15 Section 15.215(c), the 20 dB bandwidth of the emission was contained within the frequency band designated (mentioned as above) which the EUT operated. The effects, if any, from frequency sweeping, frequency hopping, other modulation techniques and frequency stability over excepted variations in temperature and supply voltage were considered.

**TEST REPORT**

**TABLE OF CONTENTS**

**1.0 GENERAL DESCRIPTION..... 5**

    1.1 Product Description .....5

    1.2 Related Submittal(s) Grants .....5

    1.3 Test Methodology .....5

    1.4 Test Facility.....5

**2.0 SYSTEM TEST CONFIGURATION..... 6**

    2.1 Justification .....6

    2.2 EUT Exercising Software.....6

    2.3 Special Accessories.....6

    2.4 Measurement Uncertainty.....6

    2.5 Support Equipment List and Description .....7

**3.0 EMISSION RESULTS ..... 8**

    3.1 Field Strength Calculation .....8

    3.2 Radiated Emission Configuration Photograph.....9

    3.3 Radiated Emission Data .....9

    3.4 Conducted Emission Configuration Photograph .....9

    3.5 Conducted Emission Data .....9

**4.0 EQUIPMENT PHOTOGRAPHS..... 18**

**5.0 PRODUCT LABELLING ..... 18**

**6.0 TECHNICAL SPECIFICATIONS ..... 18**

**7.0 INSTRUCTION MANUAL ..... 18**

**8.0 MISCELLANEOUS INFORMATION ..... 19**

    8.1 Measured Bandwidth.....19

    8.2 Emissions Test Procedures.....19

    8.3 Occupied Bandwidth .....22

**9.0 CONFIDENTIALITY REQUEST..... 24**

**10.0 EQUIPMENT LIST ..... 24**

## TEST REPORT

### 1.0 GENERAL DESCRIPTION

#### 1.1 Product Description

The Equipment Under Test (EUT), is a 2-in-1 wireless charger that is designed to work on table. The EUT is powered by 120VAC, the smartphone charge pad is operated at frequency range of 120kHz to 360kHz while the earpod charge pad is operated at frequency range of 120kHz to 150kHz. The maximum wireless power transmission for smartphone charge pad is 15W while that for earpod charge pad is 5W.

Antenna Type: Internal, Integral

For electronic filing, the brief circuit description is saved with filename: descri.pdf.

#### 1.2 Related Submittal(s) Grants

This is a single application for certification of a transmitter.

The receiver for this transmitter is exempted from the Part 15 technical rules per 15.101(b).

#### 1.3 Test Methodology

Both AC mains line-conducted and radiated emission measurements were performed according to the procedures in ANSI C63.10 (2013). All radiated measurements were performed in an 3m Chamber. Preliminary scans were performed in the 3m Chamber only to determine worst case modes. All radiated tests were performed at an antenna to EUT distance of 3 meters, unless stated otherwise in the “**Justification Section**” of this Application.

#### 1.4 Test Facility

The 3m Chamber and conducted measurement facility used to collect the radiated data is located at Workshop No. 3, G/F., World-Wide Industrial Centre, 43-47 Shan Mei Street, Fo Tan, Sha Tin, N.T., Hong Kong SAR, China. This test facility and site measurement data have been placed on file with the FCC.

## TEST REPORT

### 2.0 SYSTEM TEST CONFIGURATION

#### 2.1 Justification

The system was configured for testing in a typical fashion (as a customer would normally use it), and in the confines as outlined in ANSI C63.10 (2013).

The device was powered by 120VAC.

For maximizing emissions below 30 MHz, the EUT was rotated through 360°, the centre of the loop antenna was placed 1 meter above the ground, and the antenna polarization was changed. For maximizing emission at and above 30 MHz, the EUT was rotated through 360°, the antenna height was varied from 1 meter to 4 meters above the ground plane, and the antenna polarization was changed. This step by step procedure for maximizing emissions led to the data report in Exhibit 3.0.

The rear of unit shall be flushed with the rear of the table.

The equipment under test (EUT) was configured for testing in a typical fashion (as a customer would normally use it). The EUT was mounted to a plastic stand if necessary and placed on the wooden turntable, which enabled the engineer to maximize emissions through its placement in the three orthogonal axes.

There are different testing conditions for this EUT, standby mode, charging with the smartphone charge pad only, charging with the earpod charge pad only and charging with full load. Only the worst-case data is shown in this report.

#### 2.2 EUT Exercising Software

There was no special software to exercise the device. Once the unit is powered up, it transmits the RF Signal continuously.

#### 2.3 Special Accessories

There are no special accessories necessary for compliance of this product.

#### 2.4 Measurement Uncertainty

Decision Rule for compliance: For FCC/IC standard, the measured value must be within the limits of applicable standard without accounting for the measurement uncertainty. For EN/IEC/HKTA/HKTC standard, conformity rules will be used as per standard directly excepted EN/IEC 61000-3-2, EN/IEC 61000-3-3, HKTA1004, HKCA1008, HKTA1019, HKTA1020, HKTA1041 and HKTA1044.

Uncertainty and Compliance - Unless the standard specifically states that measured values are to be extended by the measurement uncertainty in determining compliance, all compliance determinations are based on the actual measured value.

**TEST REPORT**

2.5 Support Equipment List and Description

Description	Remark
An AC adaptor (Model: HKAP3891B-36US; Input: 100-240VAC 50/60Hz 1.2A; Output: 5.0V 3.0A, 9.0V 3.0A, 12.0V 3.0A, 15.0V 2.4A, 20.0V 1.8A)	Provided by Applicant
USB Type-C Power Supply Cable	Provided by Applicant
15W Loading	Provided by Applicant
iPhone	Provided by Intertek

2.6 Remarks

The internal RF components of the following models are identical, except for the color, customer's code, and main plug: HR2D was selected for testing; TS-24210, TS-24211, TS-24212, TS-24213, TS-24214, TS-24215, TS-24216, TS-24217, TS-24218, TS-24219, TS-24220 are the customer's codes (SKU numbers).

## TEST REPORT

### 3.0 EMISSION RESULTS

Data is included of the worst case configuration (the configuration which resulted in the highest emission levels). A sample calculation, configuration photographs and data tables of the emissions are included.

#### 3.1 Field Strength Calculation

The field strength is calculated by adding the Antenna Factor and Cable Factor, and subtracting the Amplifier Gain (if any), Average Factor (optional) from the measured reading.

The basic equation with a sample calculation is as follows:

$$FS = RA + AF + CF - AG - AV$$

where

- FS = Field Strength in dB $\mu$ V/m
- RA = Receiver Amplitude (including preamplifier) in dB $\mu$ V
- AF = Antenna Factor in dB
- CF = Cable Attenuation Factor in dB
- AG = Amplifier Gain in dB
- AV = Average Factor in dB

In the following table(s), the reading shown on the data table reflects the preamplifier gain.

An example for the calculations in the following table is as follows:

$$FS = RR + LF$$

where

- FS = Field Strength in dB $\mu$ V/m
- RR = RA - AG - AV in dB $\mu$ V
- LF = CF + AF in dB

Assume a receiver reading of 52.0 dB $\mu$ V is obtained. The antenna factor of 7.4 dB and cable factor of 1.6 dB are added. The amplifier gain of 29.0 dB and average factor of 5.0 dB are subtracted, giving a field strength of 27.0 dB $\mu$ V/m. This value in dB $\mu$ V/m was converted to its corresponding level in  $\mu$ V/m.

RA = 52.0 dB $\mu$ V/m	
AF = 7.4 dB	RR = 18.0 dB $\mu$ V
CF = 1.6 dB	LF = 9.0 dB
AG = 29.0 dB	
AV = 5.0 dB	
FS = RR + LF	
FS = 18 + 9 = 27 dB $\mu$ V/m	

Level in  $\mu$ V/m = Common Antilogarithm [(27 dB $\mu$ V/m)/20] = 22.4  $\mu$ V/m



## TEST REPORT

### 3.2 Radiated Emission Configuration Photograph

The worst case in radiated emission was found at 196.84 MHz

For electronic filing, the worst case radiated emission configuration photographs are saved with filename: setup photos.pdf.

### 3.3 Radiated Emission Data

The data on the following page lists the significant emission frequencies, the limit and the margin of compliance. Numbers with a minus sign are below the limit.

Judgment: Passed by 7.6 dB

### 3.4 Conducted Emission Configuration Photograph

The worst case in line-conducted emission was found at 3.237 MHz

For electronic filing, the worst case line-conducted configuration photographs are saved with filename: setup photos.pdf.

### 3.5 Conducted Emission Data

The plot(s) and data in the following pages list the significant emission frequencies, the limit and the margin of compliance.

Judgment: Pass by 0.4 dB

**TEST REPORT**

**CONDUCTED EMISSION**

Model: HR2D  
Date of Test: June 18, 2024  
Worst-Case Operating Mode: Standby Mode

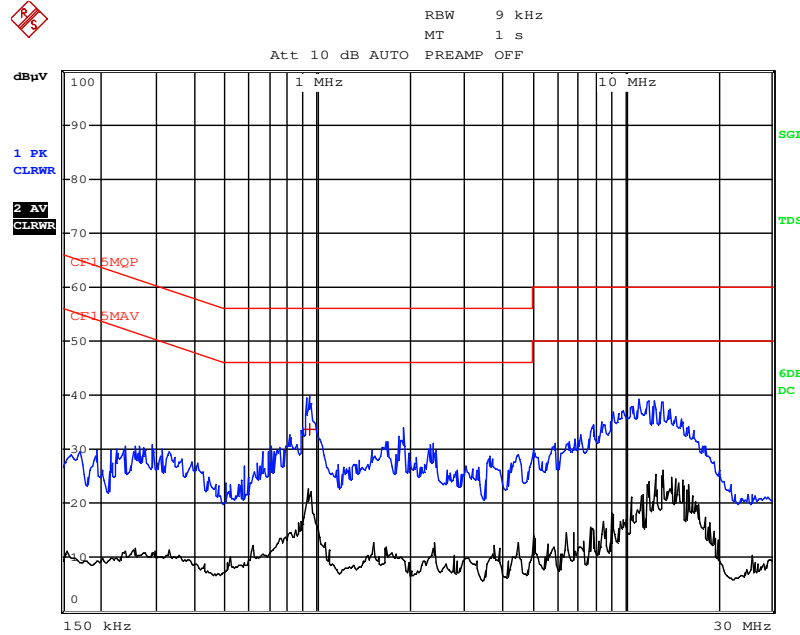

Note: Measurement Uncertainty is  $\pm 4.2$ dB at a level of confidence of 95%.

## TEST REPORT

### CONDUCTED EMISSION (CONT'D)

Model: HR2D  
Date of Test: June 18, 2024  
Worst-Case Operating Mode: Standby Mode

EDIT PEAK LIST (Final Measurement Results)				
Trace1: CF15MOP				
Trace2: CF15MAV				
Trace3: ---				
	TRACE	FREQUENCY	LEVEL dB $\mu$ V	DELTA LIMIT dB
1	Quasi Peak	942 kHz	33.72 L1	-22.28

Note: Measurement Uncertainty is  $\pm 4.2$ dB at a level of confidence of 95%.

**TEST REPORT**

**CONDUCTED EMISSION**

Model: HR2D  
Date of Test: June 18, 2024  
Worst-Case Operating Mode: Charging with Full Load

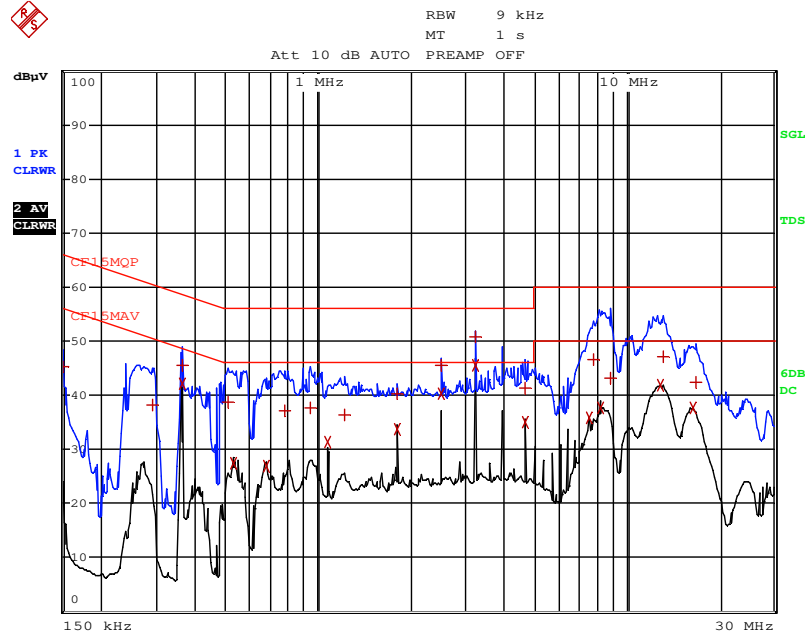

Note: Measurement Uncertainty is  $\pm 4.2$ dB at a level of confidence of 95%.

**TEST REPORT**

**CONDUCTED EMISSION (CONT'D)**

Model: HR2D  
Date of Test: June 18, 2024  
Worst-Case Operating Mode: Charging with Full Load

EDIT PEAK LIST (Final Measurement Results)				
Trace1: CF15MQP				
Trace2: CF15MAV				
Trace3: ---				
	TRACE	FREQUENCY	LEVEL dBµV	DELTA LIMIT dB
1	Quasi Peak	150 kHz	45.25 L1	-20.74
1	Quasi Peak	289.5 kHz	38.27 L1	-22.26
1	Quasi Peak	361.5 kHz	45.54 L1	-13.15
2	CISPR Average	361.5 kHz	42.14 N	-6.55
1	Quasi Peak	510 kHz	38.62 L1	-17.37
2	CISPR Average	532.5 kHz	27.49 L1	-18.50
2	CISPR Average	676.5 kHz	26.94 L1	-19.05
1	Quasi Peak	775.5 kHz	37.02 L1	-18.97
1	Quasi Peak	942 kHz	37.65 L1	-18.35
2	CISPR Average	1.077 MHz	31.38 L1	-14.61
1	Quasi Peak	1.2165 MHz	36.22 L1	-19.77
1	Quasi Peak	1.797 MHz	40.19 L1	-15.80
2	CISPR Average	1.797 MHz	33.83 N	-12.16
1	Quasi Peak	2.517 MHz	45.46 L1	-10.54
2	CISPR Average	2.517 MHz	40.30 L1	-5.69
1	Quasi Peak	3.237 MHz	50.87 N	-5.12
2	CISPR Average	3.237 MHz	45.57 N	-0.43
1	Quasi Peak	4.6725 MHz	41.41 N	-14.58
2	CISPR Average	4.6725 MHz	34.92 N	-11.07
2	CISPR Average	7.5525 MHz	35.92 N	-14.07

EDIT PEAK LIST (Final Measurement Results)				
Trace1: CF15MQP				
Trace2: CF15MAV				
Trace3: ---				
	TRACE	FREQUENCY	LEVEL dBµV	DELTA LIMIT dB
1	Quasi Peak	7.8 MHz	46.67 L1	-13.33
2	CISPR Average	8.268 MHz	37.55 N	-12.44
1	Quasi Peak	8.907 MHz	43.05 N	-16.94
2	CISPR Average	12.858 MHz	41.74 N	-8.25
1	Quasi Peak	13.128 MHz	47.03 N	-12.96
2	CISPR Average	16.3635 MHz	37.74 N	-12.25
1	Quasi Peak	16.71 MHz	42.48 N	-17.51

Note: Measurement Uncertainty is ±4.2dB at a level of confidence of 95%.

**TEST REPORT**

**RADIATED EMISSIONS**

Model: HR2D  
Date of Test: June 18, 2024  
Worst-Case Operating Mode: Standby Mode

Table 1  
Pursuant to FCC Part 15 Section 15.209 Requirement

Frequency (MHz)	Read Level (dBμV)	MaxPeak (dBμV/m)	Quasi-Peak (dBμV/m)	Limit (dBμV/m)	Margin (dB)	Height (cm)	Pol	Azimuth (deg)	Corr. (dB/m)
0.127688	48.69	---	60.09	105.48	-45.39	100.0	O	313.0	11.4
0.150978	53.17	---	64.57	104.02	-39.45	100.0	O	283.0	11.4
0.504469	34.55	46.05	---	73.55	-27.51	100.0	O	91.0	11.5
0.638794	33.65	45.15	---	71.49	-26.34	100.0	O	206.0	11.5
1.418625	27.99	39.69	---	64.56	-24.88	100.0	O	84.0	11.7
30.000000	5.02	14.02	---	40.00	-25.98	100.0	O	49.0	9.0

- NOTES:
1. Peak and Quasi-Peak Detector Data unless otherwise stated.
  2. All measurements were made at 3 meters.
  3. Negative value in the margin column shows emission below limit.
  4. Loop antenna is used for the emissions below 30MHz.
  5. Emissions within the restricted band meets the requirement of FCC Part 15 Section 15.205.
  6. Measurement Uncertainty is ±5.3dB at a level of confidence of 95%.
  7. Corr. (dB/m) = Antenna Factor (dB) + Cable Loss (dB)  
 Max Peak (dBμV/m) or Quasi-Peak (dBμV/m) = Corr. (dB/m) + Read Level (dBμV)  
 Margin (dB) = Max Peak (dBμV/m) – Limit (dBμV/m) or Quasi-Peak (dBμV/m) – Limit (dBμV/m)

**TEST REPORT**

**RADIATED EMISSIONS**

Model: HR2D  
Date of Test: June 18, 2024  
Worst-Case Operating Mode: Charging with Full Load

Table 2  
Pursuant to FCC Part 15 Section 15.209 Requirement

Frequency (MHz)	Read Level (dBµV)	MaxPeak (dBµV/m)	Quasi-Peak (dBµV/m)	Limit (dBµV/m)	Margin (dB)	Height (cm)	Pol	Azimuth (deg)	Corr. (dB/m)
0.126130	64.31	---	75.71	105.59	-29.88	100.0	O	11.0	11.4
0.358950	47.95	59.45	---	96.50	-37.05	100.0	O	155.0	11.5
0.493275	33.61	45.11	---	73.74	-28.64	100.0	O	207.0	11.5
0.683569	32.75	44.25	---	70.91	-26.66	100.0	O	305.0	11.5
1.441013	25.98	37.68	---	64.43	-26.75	100.0	O	170.0	11.7
30.000000	8.31	17.31	---	40.00	-22.69	100.0	O	85.0	9.0

- NOTES:
1. Peak and Quasi-Peak Detector Data unless otherwise stated.
  2. All measurements were made at 3 meters.
  3. Negative value in the margin column shows emission below limit.
  4. Loop antenna is used for the emissions below 30MHz.
  5. Emissions within the restricted band meets the requirement of FCC Part 15 Section 15.205.
  6. Measurement Uncertainty is ±5.3dB at a level of confidence of 95%.
  7. Corr. (dB/m) = Antenna Factor (dB) + Cable Loss (dB)  
 Max Peak (dBµV/m) or Quasi-Peak (dBµV/m) = Corr. (dB/m) + Read Level (dBµV)  
 Margin (dB) = Max Peak (dBµV/m) – Limit (dBµV/m) or Quasi-Peak (dBµV/m) – Limit (dBµV/m)

**TEST REPORT**

**RADIATED EMISSIONS**

Model: HR2D  
Date of Test: June 18, 2024  
Worst-Case Operating Mode: Standby Mode

Table 3  
Pursuant to FCC Part 15 Section 15.209 Requirement

Frequency (MHz)	Read Level (dBµV)	MaxPeak (dBµV/m)	Limit (dBµV/m)	Margin (dB)	Height (cm)	Pol	Azimuth (deg)	Corr. (dB/m)
78.257500	20.27	28.77	40.00	-11.23	100.0	V	308.0	8.5
172.226250	15.81	27.91	43.50	-15.59	100.0	V	114.0	12.1
175.136250	15.25	27.55	43.50	-15.95	100.0	V	114.0	12.3
696.026250	3.25	31.05	46.00	-14.95	100.0	H	309.0	27.8
737.493750	9.48	37.18	46.00	-8.82	200.0	H	335.0	27.7
938.162500	3.21	33.91	46.00	-12.09	200.0	H	323.0	30.7

- NOTES: 1. Peak Detector Data unless otherwise stated.  
 2. All measurements were made at 3 meters.  
 3. Negative value in the margin column shows emission below limit.  
 4. Loop antenna is used for the emissions below 30MHz.  
 5. Emissions within the restricted band meets the requirement of FCC Part 15 Section 15.205.  
 6. Measurement Uncertainty is ±5.3dB at a level of confidence of 95%.  
 7. Corr. (dB/m) = Antenna Factor (dB) + Cable Loss (dB)  
 Max Peak (dBµV/m) or Quasi-Peak (dBµV/m) = Corr. (dB/m) + Read Level (dBµV)  
 Margin (dB) = Max Peak (dBµV/m) – Limit (dBµV/m) or Quasi-Peak (dBµV/m) – Limit (dBµV/m)



**TEST REPORT**

**RADIATED EMISSIONS**

Model: HR2D  
Date of Test: June 18, 2024  
Worst-Case Operating Mode: Charging with Full Load

Table 4  
Pursuant to FCC Part 15 Section 15.209 Requirement

Frequency (MHz)	Read Level (dBµV)	MaxPeak (dBµV/m)	Quasi-Peak (dBµV/m)	Limit (dBµV/m)	Margin (dB)	Height (cm)	Pol	Azimuth (deg)	Corr. (dB/m)
35.213750	15.05	29.35	---	40.00	-10.65	100.0	V	9.0	14.3
45.883750	16.67	26.27	---	40.00	-13.73	100.0	V	149.0	9.6
76.802500	23.93	32.53	---	40.00	-7.47	100.0	V	313.0	8.6
170.286250	26.23	38.23	---	43.50	-5.27	100.0	V	119.0	12.0
196.840000	23.34	---	35.94	43.50	-7.56	100.0	V	359.0	12.6
907.001250	7.97	37.67	---	46.00	-8.33	200.0	V	338.0	29.7

- NOTES:
1. Peak and Quasi-Peak Detector Data unless otherwise stated.
  2. All measurements were made at 3 meters.
  3. Negative value in the margin column shows emission below limit.
  4. Loop antenna is used for the emissions below 30MHz.
  5. Emissions within the restricted band meets the requirement of FCC Part 15 Section 15.205.
  6. Measurement Uncertainty is ±5.3dB at a level of confidence of 95%.
  7. Corr. (dB/m) = Antenna Factor (dB) + Cable Loss (dB)  
 Max Peak (dBµV/m) or Quasi-Peak (dBµV/m) = Corr. (dB/m) + Read Level (dBµV)  
 Margin (dB) = Max Peak (dBµV/m) – Limit (dBµV/m) or Quasi-Peak (dBµV/m) – Limit (dBµV/m)

## TEST REPORT

### 4.0 EQUIPMENT PHOTOGRAPHS

For electronic filing, the photographs are saved with filename: external photos.pdf and internal photos.pdf.

### 5.0 PRODUCT LABELLING

For electronics filing, the FCC ID label artwork and the label location are saved with filename: label.pdf.

### 6.0 TECHNICAL SPECIFICATIONS

For electronic filing, the block diagram and schematic of the tested EUT are saved with filename: block.pdf and circuit.pdf respectively.

### 7.0 INSTRUCTION MANUAL

For electronic filing, a preliminary copy of the Instruction Manual is saved with filename: manual.pdf.

This manual will be provided to the end-user with each unit sold/leased in the United States.

## TEST REPORT

### 8.0 MISCELLANEOUS INFORMATION

The miscellaneous information includes details of the test procedure and measured bandwidth.

#### 8.1 Measured Bandwidth

Pursuant to FCC Part 15 Section 15.215(c), the 20dB bandwidth of the emission was contained within the frequency band designed (mentioned as above) which the EUT operated. The effects, if any, from frequency sweeping, frequency hopping, other modulation techniques and frequency stability over expected variations in temperature and supply voltage were considered.

#### 8.2 Emissions Test Procedures

The following is a description of the test procedure used by Intertek Testing Services Hong Kong Ltd. in the measurements of transmitter operating under the Part 15, Subpart C rules.

The transmitting equipment under test (EUT) is placed on a wooden turntable which is four feet in diameter and approximately 0.8m in height above the ground plane for emission measurement at or below 1GHz and 1.5m in height above the ground plane for emission measurement above 1GHz. During the radiated emissions test, the turntable is rotated and any cables leaving the EUT are manipulated to find the configuration resulting in maximum emissions. The EUT is adjusted through all three orthogonal axis to obtain maximum emission levels. The antenna height and polarization are also varied during the testing to search for maximum signal levels. The height of the antenna is varied from one to four meters.

Detector function for radiated emissions is in peak mode. Average readings, when required, are taken by measuring the duty cycle of the equipment under test and subtracting the corresponding amount in dB from the measured peak readings. A detailed description for the calculation of the average factor can be found in Exhibit 8.3.

The frequency range scanned is from the lowest radio frequency signal generated in the device which is greater than 9 kHz to the tenth harmonic of the highest fundamental frequency or 40 GHz, whichever is lower. For line conducted emissions, the range scanned is 150 kHz to 30 MHz.

The EUT is warmed up for 15 minutes prior to the test.

AC power to the unit is varied from 85% to 115% nominal and variation in the fundamental emission field strength is recorded. If battery powered, a new, fully charged battery is used.

Conducted measurements were made as described in ANSI C63.10 (2013).

The IF bandwidth used for measurement of radiated signal strength was 100 kHz or greater when frequency is below 1000 MHz. Where pulsed transmissions of short enough pulse duration warrant, a greater bandwidth is selected according to the recommendations of Hewlett Packard Application Note 150-2. A discussion of whether pulse desensitivity is applicable to this unit is included in this report (See Exhibit 8.1). Above 1000 MHz, a resolution bandwidth of 1 MHz is used.

Transmitter measurements are normally conducted at a measurement distance of three meters. However, to assure low enough noise floor in the forbidden bands and above 1 GHz, signals are acquired at a distance of one meter or less. All measurements are extrapolated to three meters using inverse scaling, unless otherwise reported. Measurements taken at a closer distance are so marked.

## TEST REPORT

### 8.2.1 Radiated Emission Test Setup

The figure below shows the test setup, which is utilized to make these measurements.

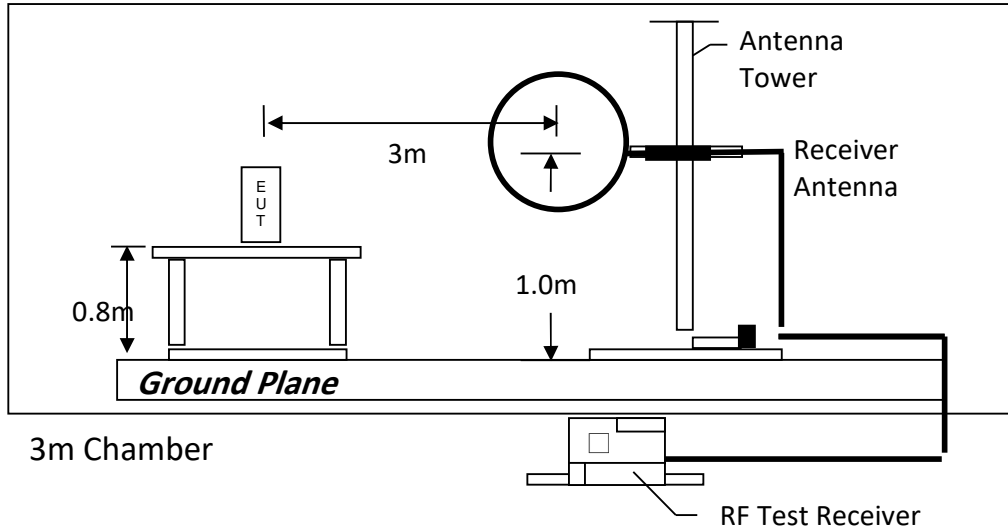

Test setup of radiated emissions up to 30MHz

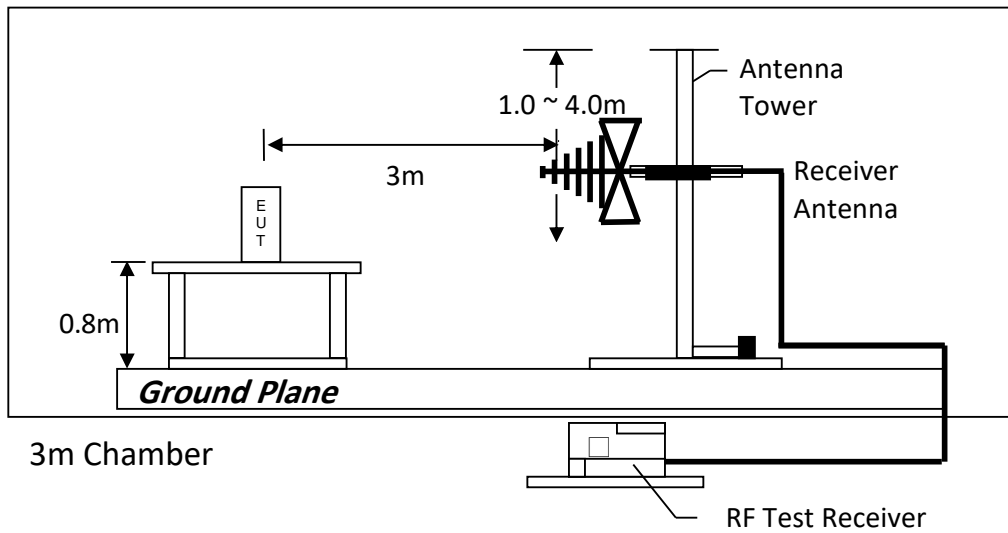

Test setup of radiated emissions above 1GHz

## TEST REPORT

### 8.2.2 Conducted Emission Test Procedures

For tabletop equipment, the EUT along with its peripherals were placed on a 1.0m(W)×1.5m(L) and 0.8m in height wooden table. For floor-standing equipment, the EUT and all cables were insulated, if required, from the ground plane by up to 12 mm of insulating material. The EUT was adjusted to maintain a 0.4 meter space from a vertical reference plane. The EUT was connected to power mains through a line impedance stabilization network (LISN), which provided 50 ohm coupling impedance for measuring instrument and the chassis ground was bounded to the horizontal ground plane of shielded room. The excess power cable between the EUT and the LISN was bundled.

All connecting cables of EUT and peripherals were moved to find the maximum emission.

### 8.2.3 Conducted Emission Test Setup

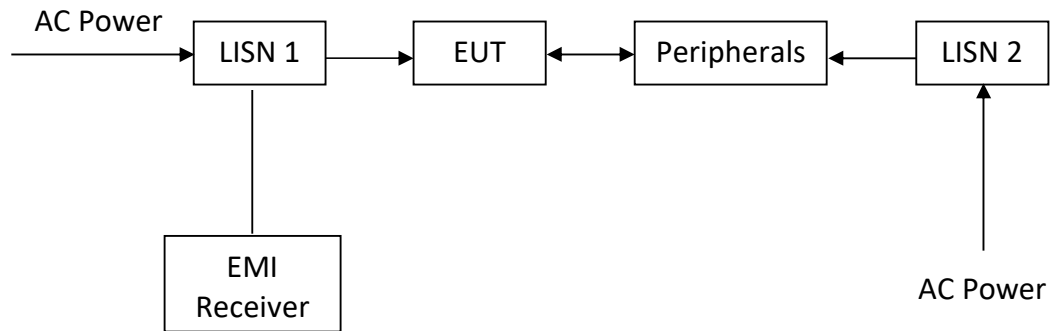

**TEST REPORT**

8.3 Occupied Bandwidth

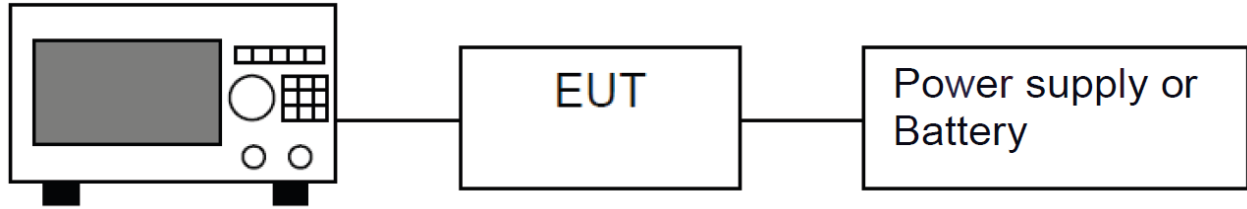

**Spectrum Analyzer**

Block diagram of Test setup

Occupied Bandwidth Results: Standby Mode

Frequency (kHz)	Occupied Bandwidth (Hz)
127.8	60.6
151	86.6

The worst case is shown as below

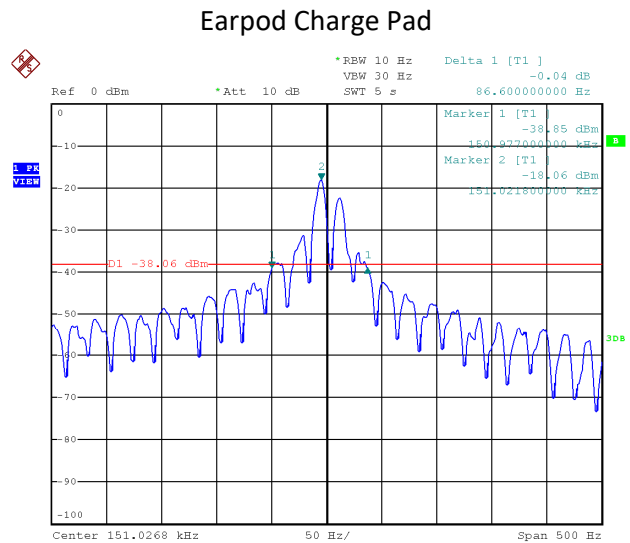
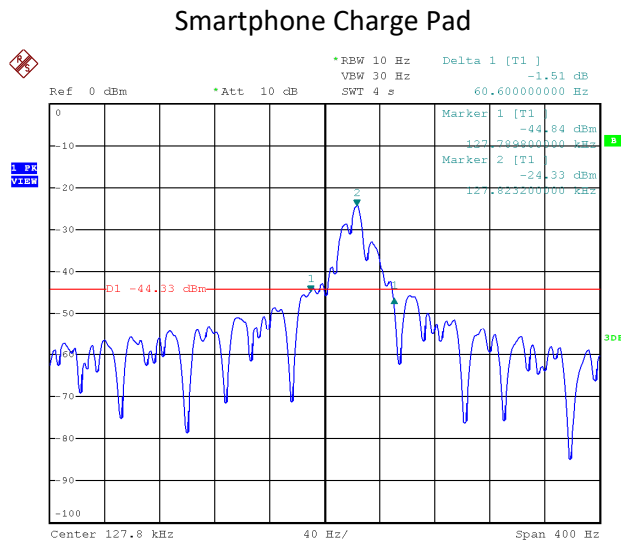

**TEST REPORT**

Occupied Bandwidth Results: Charging with Full Load

Frequency (kHz)	Occupied Bandwidth (Hz)
123.1	1330
359.5	1223

The worst case is shown as below

Smartphone Charge Pad

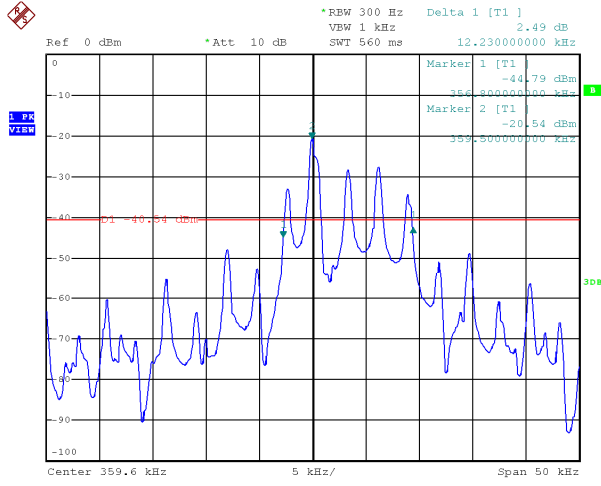

Earpod Charge Pad

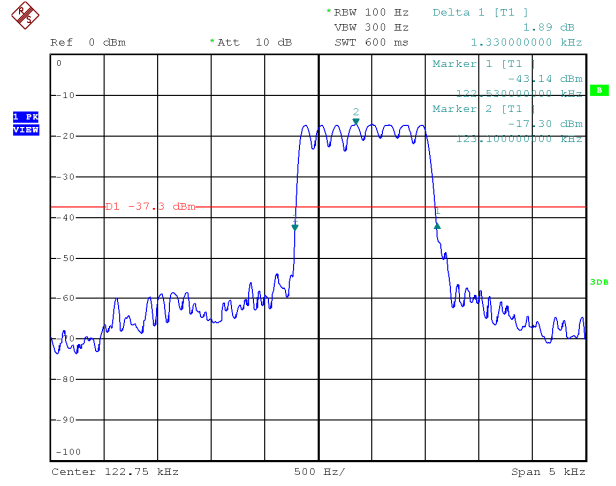

## TEST REPORT

### 9.0 CONFIDENTIALITY REQUEST

For electronic filing, a preliminary copy of the confidentiality request is saved with filename: request.pdf.

### 10.0 EQUIPMENT LIST

#### 1) Radiated Emissions Test

Equipment	EMI Test Receiver (9kHz to 26.5GHz)	Biconical Antenna (30MHz to 300MHz)	Log Periodic Antenna
Registration No.	EW-3156	EW-3242	EW-3243
Manufacturer	ROHDESCHWARZ	EMCO	EMCO
Model No.	ESR26	3110C	3148B
Calibration Date	January 31, 2024	April 26, 2022	October 30, 2022
Calibration Due Date	January 31, 2025	July 26, 2024	July 30, 2024

Equipment	Double Ridged Guide Antenna (1GHz - 18GHz)	Active Loop Antenna (H-field) (9kHz to 30MHz)	RF Preamplicifier (9kHz to 6000MHz)
Registration No.	EW-0194	EW-3326	EW-3006b
Manufacturer	EMCO	EMCO	SCHWARZBECK
Model No.	3115	6502	BBV9718
Calibration Date	May 10, 2023	January 05, 2024	October 20, 2023
Calibration Due Date	November 10, 2024	July 05, 2025	October 20, 2024

Equipment	14m Double Shield RF Cable (9kHz - 6GHz)	RF Cable 14m (1GHz to 26.5GHz)	12 metre RF Cable (1-40)GHz
Registration No.	EW-2376	EW-2781	EW-2774
Manufacturer	RADIALL	GREATBILLION	GREATBILLION
Model No.	n m/br56/bnc m 14m	SMA m/SHF5MPU /SMA m ra14m,26G	SMA m-m ra 12m 40G outdoor
Calibration Date	September 19, 2023	January 16, 2024	January 16, 2024
Calibration Due Date	September 19, 2024	January 16, 2025	January 16, 2025

Equipment	Pyramidal Horn Antenna
Registration No.	EW-0905
Manufacturer	EMCO
Model No.	3160-09
Calibration Date	December 15, 2023
Calibration Due Date	June 15, 2025



**TEST REPORT**

2) Conducted Emissions Test

<b>Equipment</b>	<b>RF Cable 240cm (RG142) (9kHz to 30MHz)</b>	<b>Artificial Mains Network</b>	<b>EMI Test Receiver (9kHz to 3GHz)</b>
Registration No.	EW-2454	EW-3360	EW-3095
Manufacturer	RADIALL	ROHDESCHWARZ	ROHDESCHWARZ
Model No.	Bnc m st / 142 / bnc mra 240cm	ENV-216	ESCI
Calibration Date	June 13, 2023	April 07, 2024	January 18, 2024
Calibration Due Date	September 13, 2024	April 07, 2025	January 18, 2025

3) OBW Measurement

<b>Equipment</b>	<b>EMI Test Receiver (9kHz to 3GHz)</b>
Registration No.	EW-3095
Manufacturer	ROHDESCHWARZ
Model No.	ESCI
Calibration Date	January 18, 2024
Calibration Due Date	January 18, 2025

4) Control Software for Radiated Emission

<b>Software Information</b>	
Software Name	EMC32
Manufacturer	ROHDESCHWARZ
Software version	10.50.40

**END OF TEST REPORT**