



Shenzhen CTA Testing Technology Co., Ltd.

Room 106, Building 1, Yibaolai Industrial Park, Qiaotou Community, Fuhai Street, Bao'an District, Shenzhen, China

TEST REPORT

FCC PART 15 SUBPART C 15.249 & RSS-210 Issue 10

Report Reference No.....: CTA24022000101

FCC ID..... : 2AUZX-BVSZWU

IC : 26714-BVSZWU

Compiled by

(position+printed name+signature)...: File administrators Kevin Liu

Kevin Liu

Supervised by

(position+printed name+signature)...: Project Engineer Kevin Liu

Kevin Liu

Approved by

(position+printed name+signature)...: RF Manager Eric Wang

Eric Wang

Date of issue.....: Feb. 27, 2024

Testing Laboratory Name: Shenzhen CTA Testing Technology Co., Ltd.

Address: Room 106, Building 1, Yibaolai Industrial Park, Qiaotou Community, Fuhai Street, Bao'an District, Shenzhen, China

Applicant's name.....: Ubitech Limited

Address: Unit 12, 7/F Block A, Hi-Tech Industrial Centre, 5-21 Pak Tin Par Street, Tsuen Wan, NT, Hong Kong

Test specification

Standard.....: 47 CFR FCC Part 15 Subpart C 15.249
RSS-210 Issue 10 Annex B.10

Shenzhen CTA Testing Technology Co., Ltd. All rights reserved.

This publication may be reproduced in whole or in part for non-commercial purposes as long as the Shenzhen CTA Testing Technology Co., Ltd. is acknowledged as copyright owner and source of the material. Shenzhen CTA Testing Technology Co., Ltd. takes no responsibility for and will not assume liability for damages resulting from the reader's interpretation of the reproduced material due to its placement and context.

Test item description: Z-Wave Intelligent Ball Valve Servo

Trade Mark: N/A

Manufacturer: ZHUHAI SHINTECH ELECTRONIC & TECHNOLOGICAL CO., LTD

Model/Type reference(HVIN): BVSZWU

List Model(HVIN): N/A

Ratings: 12.0V/1A

Result.....: **PASS**

Shenzhen CTA Testing Technology Co., Ltd.

Room 106, Building 1, Yibaolai Industrial Park, Qiaotou Community, Fuhai Street, Bao'an District, Shenzhen, China
Tel:+86-755 2322 5875 E-mail:cta@cta-test.cn Web:http://www.cta-test.cn

TEST REPORT

Equipment under Test : Z-Wave Intelligent Ball Valve Servo

Model /Type(HVIN) : BVSZWU

Listed Models(HVIN) : N/A

Applicant : **Ubitech Limited**

Address : Unit 12, 7/F Block A, Hi-Tech Industrial Centre, 5-21 Pak Tin Par Street, Tsuen Wan, NT, Hong Kong

Manufacturer : **ZHUHAI SHINTECH ELECTRONIC & TECHNOLOGICAL CO., LTD**

Address : 2th Floor, Building Ano.7 Pingxi3 Road, Nanping Technology Industrial Park, Zhuhai, China

Test Result:	PASS
---------------------	-------------

The test report merely corresponds to the test sample.
It is not permitted to copy extracts of these test result without the written permission of the test laboratory.

Contents

1	<u>TEST STANDARDS</u>	4
2	<u>SUMMARY</u>	5
2.1	General Remarks	5
2.2	Product Description	5
2.3	Equipment Under Test	5
2.4	Short description of the Equipment under Test (EUT)	5
2.5	EUT operation mode	6
2.6	Block Diagram of Test Setup	6
2.7	Special Accessories	6
2.8	Related Submittal(s) / Grant (s)	6
2.9	Modifications	6
3	<u>TEST ENVIRONMENT</u>	7
3.1	Address of the test laboratory	7
3.2	Test Facility	7
3.3	Environmental conditions	7
3.4	Summary of measurement results	8
3.5	Statement of the measurement uncertainty	8
3.6	Equipments Used during the Test	8
4	<u>TEST CONDITIONS AND RESULTS</u>	10
4.1	Conducted Emissions Test	10
4.2	Radiated Emissions and Band Edge	19
4.3	Occupied Bandwidth Measurement	29
4.4	Antenna Requirement	31
5	<u>TEST SETUP PHOTOS OF THE EUT</u>	32
6	<u>PHOTOS OF THE EUT</u>	33

1 TEST STANDARDS

The tests were performed according to following standards:

FCC Rules Part 15.249: Operation within the bands 902 - 928 MHz, 2400 - 2483.5 MHz, 5725 - 5875 MHz, and 24.0 - 24.25 GHz.

RSS-210 Issue 10: Licence-Exempt Radio Apparatus: Category I Equipment

RSS-Gen Issue 5: — General Requirements for Compliance of Radio Apparatus

ANSI C63.10: 2013: American National Standard for Testing Unlicensed Wireless Devices

2 SUMMARY

2.1 General Remarks

Date of receipt of test sample	:	Jan. 22, 2024
Testing commenced on	:	Feb. 18, 2024
Testing concluded on	:	Feb. 26, 2024

2.2 Product Description

Product Name:	Z-Wave Intelligent Ball Valve Servo
Model/Type reference(HVIN):	BVSZWU
Power supply:	DC 12V from adapter
Adapter information:	Model: ASSA107A-120100 Input: 100-240V~, 50/60Hz, 0.45A Output: 12.0V==1.0A
Hardware Version:	REV:3.1
Software Version:	V3.2.17
Test samples ID:	CTA240220001-1# (Engineer sample) CTA240220001-2# (Normal sample)
Z-wave	
Modulation:	FSK/GFSK/DSSS-OQPSK
Operation frequency:	908.42MHz, 912MHz, 916MHz, 920MHz
Channel number:	4
Antenna type:	Helix antenna
Antenna gain:	-6.39dBi

Note:Antenna gain is provide by the manufacturer.

2.3 Equipment Under Test

Power supply system utilised

Power supply voltage	:	<input type="radio"/> 230V / 50 Hz	<input type="radio"/> 120V / 60Hz
		<input type="radio"/> 12 V DC	<input type="radio"/> 24 V DC
		<input checked="" type="radio"/> Other (specified in blank below)	

DC 12V From adapter

2.4 Short description of the Equipment under Test (EUT)

This is a Z-Wave Intelligent Ball Valve Servo.

For more details, refer to the user's manual of the EUT.

2.5 EUT operation mode

The Applicant provides communication tools software (CustosGeneralTool.UI) to control the EUT for staying in continuous transmitting (Duty Cycle more than 98%) and receiving mode for testing .There are 4 channels provided to the EUT.

Operation Frequency:

Channel	Frequency (MHz)
00	908.42
01	916.00
02	912.00
03	920.00

2.6 Block Diagram of Test Setup

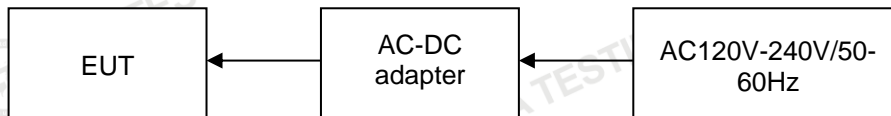

2.7 Special Accessories

Follow auxiliary equipment(s) test with EUT that provided by the manufacturer or laboratory is listed as follow:

Description	Manufacturer	Model	Technical Parameters	Certificate	Provided by
/	/	/	/	/	/
/	/	/	/	/	/
/	/	/	/	/	/
/	/	/	/	/	/

2.8 Related Submittal(s) / Grant (s)

This submittal(s) (test report) is intended for the device filing to comply with Section 15.249 of the FCC Part 15, Subpart C and RSS-210.

2.9 Modifications

No modifications were implemented to meet testing criteria.

3 TEST ENVIRONMENT

3.1 Address of the test laboratory

Shenzhen CTA Testing Technology Co., Ltd.

Room 106, Building 1, Yibaolai Industrial Park, Qiaotou Community, Fuhai Street, Bao'an District, Shenzhen, China

3.2 Test Facility

The test facility is recognized, certified, or accredited by the following organizations:

FCC-Registration No.: 517856 Designation Number: CN1318

Shenzhen CTA Testing Technology Co., Ltd. has been listed on the US Federal Communications Commission list of test facilities recognized to perform electromagnetic emissions measurements.

A2LA-Lab Cert. No.: 6534.01

Shenzhen CTA Testing Technology Co., Ltd. has been listed by American Association for Laboratory Accreditation to perform electromagnetic emission measurement.

ISED#: 27890 CAB identifier: CN0127

Shenzhen CTA Testing Technology Co., Ltd. has been listed by Innovation, Science and Economic Development Canada to perform electromagnetic emission measurement.

The 3m-Semi anechoic test site fulfils CISPR 16-1-4 according to ANSI C63.10 and CISPR 16-1-4:2010.

3.3 Environmental conditions

During the measurement the environmental conditions were within the listed ranges:

Radiated Emission:

Temperature:	24 ° C
Humidity:	46 %
Atmospheric pressure:	950-1050mbar

AC Power Conducted Emission:

Temperature:	25 ° C
Humidity:	47 %
Atmospheric pressure:	950-1050mbar

Conducted testing:

Temperature:	24 ° C
Humidity:	46 %
Atmospheric pressure:	950-1050mbar

Shenzhen CTA Testing Technology Co., Ltd.

Room 106, Building 1, Yibaolai Industrial Park, Qiaotou Community, Fuhai Street, Bao'an District, Shenzhen, China

Tel:+86-755 2322 5875 E-mail:cta@cta-test.cn Web:http://www.cta-test.cn

3.4 Summary of measurement results

FCC & IC requirement		
FCC Part 15.249(a) RSS-210 Annex B.10(a)	Field Strength of Fundamental	PASS
FCC Part 15.209(a)/15.205(a)/15.249(a)(d)(e) RSS-210 Annex B.10(a)(b)/RSS-Gen 8.9	Spurious Emission	PASS
FCC Part 15.215(c) RSS-Gen 6.7	99% and 20dB Occupied Bandwidth	PASS
FCC Part 15.207 RSS-Gen 8.8	Conducted Emission	PASS
FCC Part 15.203 RSS-Gen 6.8	Antenna Requirement	PASS

3.5 Statement of the measurement uncertainty

The data and results referenced in this document are true and accurate. The reader is cautioned that there may be errors within the calibration limits of the equipment and facilities. The measurement uncertainty was calculated for all measurements listed in this test report acc. to TR-100028-01 "Electromagnetic compatibility and Radio spectrum Matters (ERM);Uncertainties in the measurement of mobile radio equipment characteristics; Part 1" and TR-100028-02 "Electromagnetic compatibility and Radio spectrum Matters (ERM);Uncertainties in the measurement of mobile radio equipment characteristics; Part 2 " and is documented in the Shenzhen CTA Testing Technology Co., Ltd. quality system acc. to DIN EN ISO/IEC 17025. Furthermore, component and process variability of devices similar to that tested may result in additional deviation. The manufacturer has the sole responsibility of continued compliance of the device.

Hereafter the best measurement capability for Shenzhen CTA Testing Technology Co., Ltd. :

Test	Range	Measurement Uncertainty	Notes
Radiated Emission	30~1000MHz	4.06 dB	(1)
Radiated Emission	1~18GHz	5.14 dB	(1)
Radiated Emission	18-40GHz	5.38 dB	(1)
Conducted Disturbance	0.15~30MHz	2.14 dB	(1)

- (1) This uncertainty represents an expanded uncertainty expressed at approximately the 95% confidence level using a coverage factor of k=2.

3.6 Equipments Used during the Test

Test Equipment	Manufacturer	Model No.	Equipment No.	Calibration Date	Calibration Due Date
LISN	R&S	ENV216	CTA-308	2023/08/02	2024/08/01
LISN	R&S	ENV216	CTA-314	2023/08/02	2024/08/01
EMI Test Receiver	R&S	ESPI	CTA-307	2023/08/02	2024/08/01
EMI Test Receiver	R&S	ESCI	CTA-306	2023/08/02	2024/08/01
Spectrum Analyzer	Agilent	N9020A	CTA-301	2023/08/02	2024/08/01
Spectrum Analyzer	R&S	FSP	CTA-337	2023/08/02	2024/08/01
Vector Signal generator	Agilent	N5182A	CTA-305	2023/08/02	2024/08/01
Analog Signal Generator	R&S	SML03	CTA-304	2023/08/02	2024/08/01
Universal Radio Communication	CMW500	R&S	CTA-302	2023/08/02	2024/08/01
Temperature and humidity meter	Chigo	ZG-7020	CTA-326	2023/08/02	2024/08/01

Shenzhen CTA Testing Technology Co., Ltd.

Room 106, Building 1, Yibaolai Industrial Park, Qiaotou Community, Fuhai Street, Bao'an District, Shenzhen, China
Tel:+86-755 2322 5875 E-mail:cta@cta-test.cn Web:http://www.cta-test.cn

Ultra-Broadband Antenna	Schwarzbeck	VULB9163	CTA-310	2021/08/07	2024/08/06
Horn Antenna	Schwarzbeck	BBHA 9120D	CTA-309	2021/08/07	2024/08/06
Loop Antenna	Zhinan	ZN30900C	CTA-311	2021/08/07	2024/08/06
Horn Antenna	Beijing Hangwei Dayang	OBH100400	CTA-336	2021/08/07	2024/08/06
Amplifier	Schwarzbeck	BBV 9745	CTA-312	2023/08/02	2024/08/01
Amplifier	Taiwan chengyi	EMC051845B	CTA-313	2023/08/02	2024/08/01
Directional coupler	NARDA	4226-10	CTA-303	2023/08/02	2024/08/01
High-Pass Filter	XingBo	XBLBQ-GTA18	CTA-402	2023/08/02	2024/08/01
High-Pass Filter	XingBo	XBLBQ-GTA27	CTA-403	2023/08/02	2024/08/01
Automated filter bank	Tonscend	JS0806-F	CTA-404	2023/08/02	2024/08/01
Power Sensor	Agilent	U2021XA	CTA-405	2023/08/02	2024/08/01
Amplifier	Schwarzbeck	BBV9719	CTA-406	2023/08/02	2024/08/01

4 TEST CONDITIONS AND RESULTS

4.1 Conducted Emissions Test

LIMIT

According to FCC CFR Title 47 Part 15 Subpart C Section 15.207 and RSS Gen 8.8, AC Power Line Conducted Emissions Limits for Licence-Exempt Radio Apparatus as below:

Frequency range (MHz)	Limit (dBuV)	
	Quasi-peak	Average
0.15-0.5	66 to 56*	56 to 46*
0.5-5	56	46
5-30	60	50

* Decreases with the logarithm of the frequency.

TEST CONFIGURATION

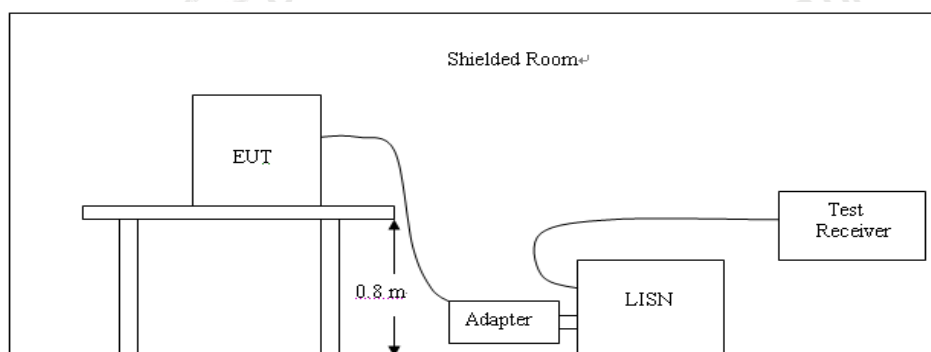

TEST PROCEDURE

1. The equipment was set up as per the test configuration to simulate typical actual usage per the user's manual. The EUT is a tabletop system; a wooden table with a height of 0.8 meters is used and is placed on the ground plane as per ANSI C63.10:2013.
2. Support equipment, if needed, was placed as per ANSI C63.10:2013.
3. All I/O cables were positioned to simulate typical actual usage as per ANSI C63.10:2013.
4. If a EUT received DC power from the USB Port of Notebook PC, the PC's adapter received AC120V/60Hz power through a Line Impedance Stabilization Network (LISN) which supplied power source and was grounded to the ground plane.
5. All support equipments received AC power from a second LISN, if any.
6. The EUT test program was started. Emissions were measured on each current carrying line of the EUT using a spectrum Analyzer / Receiver connected to the LISN powering the EUT. The LISN has two monitoring points: Line 1 (Hot Side) and Line 2 (Neutral Side). Two scans were taken: one with Line 1 connected to Analyzer / Receiver and Line 2 connected to a 50 ohm load; the second scan had Line 1 connected to a 50 ohm load and Line 2 connected to the Analyzer / Receiver.
7. Analyzer / Receiver scanned from 150 KHz to 30MHz for emissions in each of the test modes.
8. During the above scans, the emissions were maximized by cable manipulation.

TEST RESULTS

Remark: Both 120 VAC, 50/60 Hz and 240 VAC, 50/60 Hz power supply(power supply from adapter)have been tested, only the worst result of 120 VAC, 60 Hz was reported as below:

Test Frequency:	908.42MHz	Polarization	L
-----------------	-----------	--------------	---

Test Graph

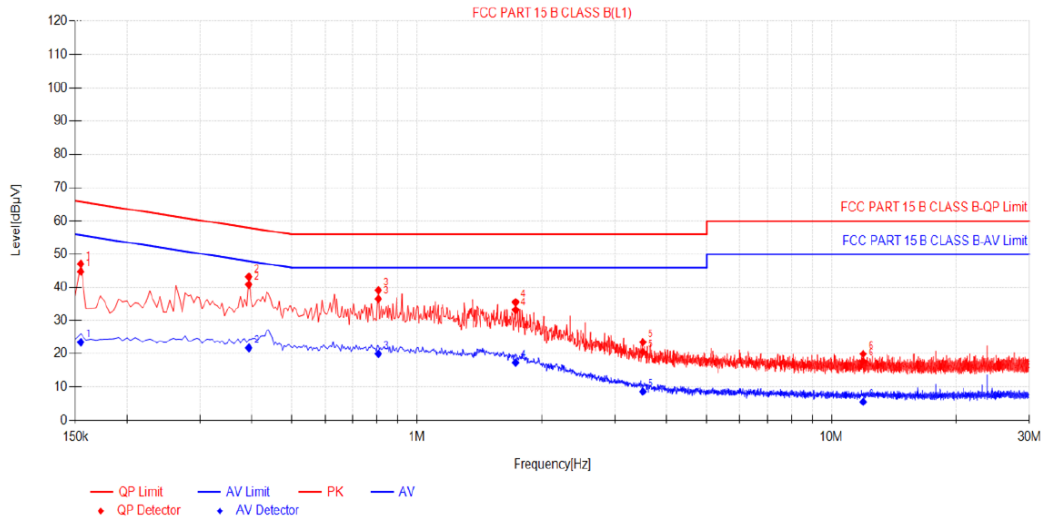

Final Data List

NO.	Freq. [MHz]	Factor [dB]	QP Reading[dBµV]	QP Value [dBµV]	QP Limit [dBµV]	QP Margin [dB]	AV Reading [dBµV]	AV Value [dBµV]	AV Limit [dBµV]	AV Margin [dB]	Verdict
1	0.1545	9.89	34.93	44.82	65.75	20.93	13.57	23.46	55.75	32.29	PASS
2	0.393	9.87	31.00	40.87	58.00	17.13	11.93	21.80	48.00	26.20	PASS
3	0.807	9.98	26.49	36.47	56.00	19.53	10.04	20.02	46.00	25.98	PASS
4	1.7295	9.91	23.23	33.14	56.00	22.86	7.42	17.33	46.00	28.67	PASS
5	3.507	9.97	10.55	20.52	56.00	35.48	-1.29	8.68	46.00	37.32	PASS
6	11.9265	10.27	7.53	17.80	60.00	42.20	-4.72	5.55	50.00	44.45	PASS

- Note:1).QP Value (dBµV)= QP Reading (dBµV)+ Factor (dB)
- 2). Factor (dB)=insertion loss of LISN (dB) + Cable loss (dB)
- 3). QPMargin(dB) = QP Limit (dBµV) - QP Value (dBµV)
- 4). AVMargin(dB) = AV Limit (dBµV) - AV Value (dBµV)

Test Frequency:	908.42MHz	Polarization	N
-----------------	-----------	--------------	---

Test Graph

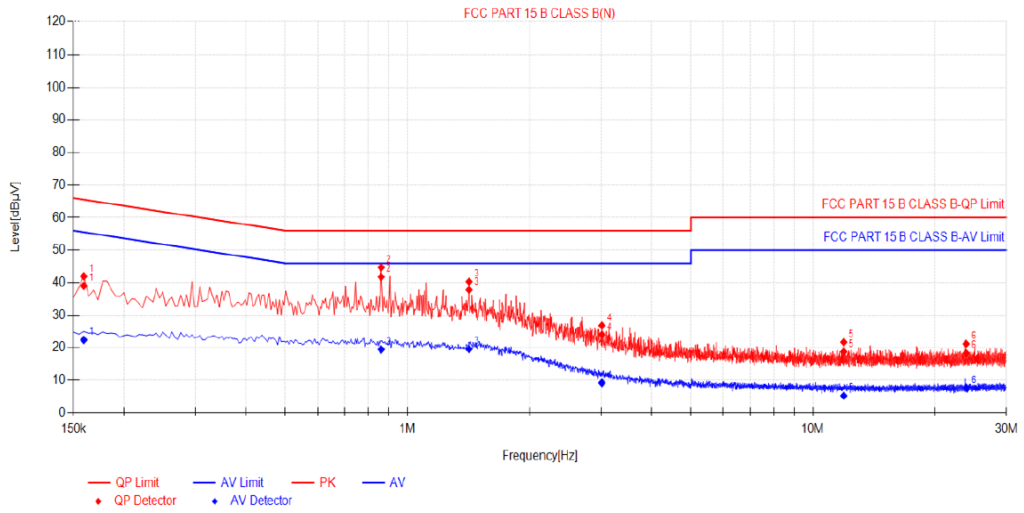

Final Data List

NO.	Freq. [MHz]	Factor [dB]	QP Reading[dBμV]	QP Value [dBμV]	QP Limit [dBμV]	QP Margin [dB]	AV Reading [dBμV]	AV Value [dBμV]	AV Limit [dBμV]	AV Margin [dB]	Verdict
1	0.159	10.03	29.00	39.03	65.52	26.49	12.37	22.40	55.52	33.12	PASS
2	0.861	10.13	31.62	41.75	56.00	14.25	9.35	19.48	46.00	26.52	PASS
3	1.419	10.14	27.66	37.80	56.00	18.20	9.46	19.60	46.00	26.40	PASS
4	3.0165	10.24	13.77	24.01	56.00	31.99	-1.03	9.21	46.00	36.79	PASS
5	11.9175	10.41	8.38	18.79	60.00	41.21	-5.19	5.22	50.00	44.78	PASS
6	23.865	10.67	7.68	18.35	60.00	41.65	-2.99	7.68	50.00	42.32	PASS

- Note:1).QP Value (dBμV)= QP Reading (dBμV)+ Factor (dB)
 2). Factor (dB)=insertion loss of LISN (dB) + Cable loss (dB)
 3). QPMargin(dB) = QP Limit (dBμV) - QP Value (dBμV)
 4). AVMargin(dB) = AV Limit (dBμV) - AV Value (dBμV)

Test Frequency:	916.00MHz	Polarization	L
-----------------	-----------	--------------	---

Test Graph

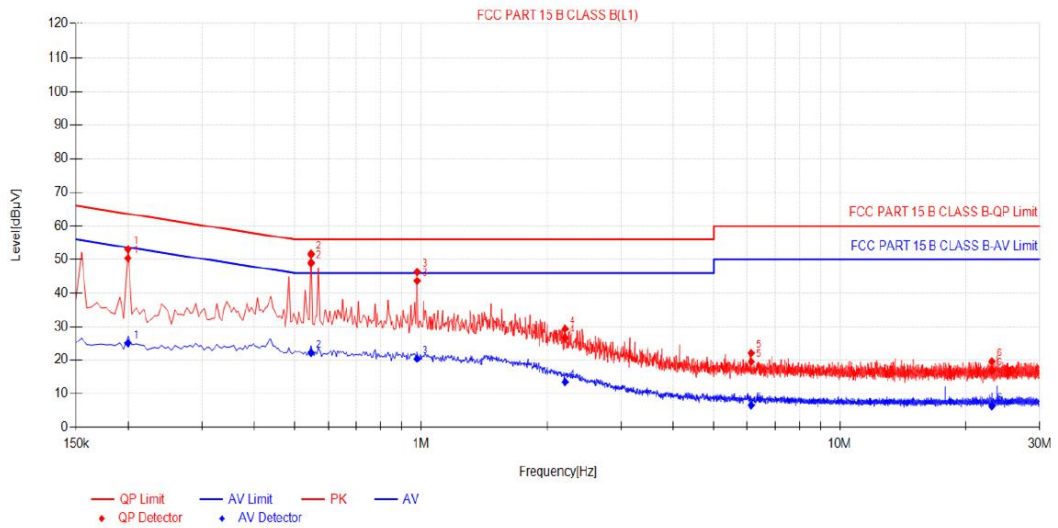

Final Data List

NO.	Freq. [MHz]	Factor [dB]	QP Reading[dBµV]	QP Value [dBµV]	QP Limit [dBµV]	QP Margin [dB]	AV Reading [dBµV]	AV Value [dBµV]	AV Limit [dBµV]	AV Margin [dB]	Verdict
1	0.1995	10.10	40.32	50.42	63.63	13.21	14.99	25.09	53.63	28.54	PASS
2	0.546	10.03	38.98	49.01	56.00	6.99	12.19	22.22	46.00	23.78	PASS
3	0.978	9.94	33.70	43.64	56.00	12.36	10.49	20.43	46.00	25.57	PASS
4	2.2065	10.00	16.69	26.69	56.00	29.31	3.50	13.50	46.00	32.50	PASS
5	6.1395	10.16	9.38	19.54	60.00	40.46	-3.59	6.57	50.00	43.43	PASS
6	23.073	10.48	6.52	17.00	60.00	43.00	-4.14	6.34	50.00	43.66	PASS

Note:1).QP Value (dBµV)= QP Reading (dBµV)+ Factor (dB)

2). Factor (dB)=insertion loss of LISN (dB) + Cable loss (dB)

3). QPMargin(dB) = QP Limit (dBµV) - QP Value (dBµV)

4). AVMargin(dB) = AV Limit (dBµV) - AV Value (dBµV)

Test Frequency:	916.00MHz	Polarization	N
-----------------	-----------	--------------	---

Test Graph

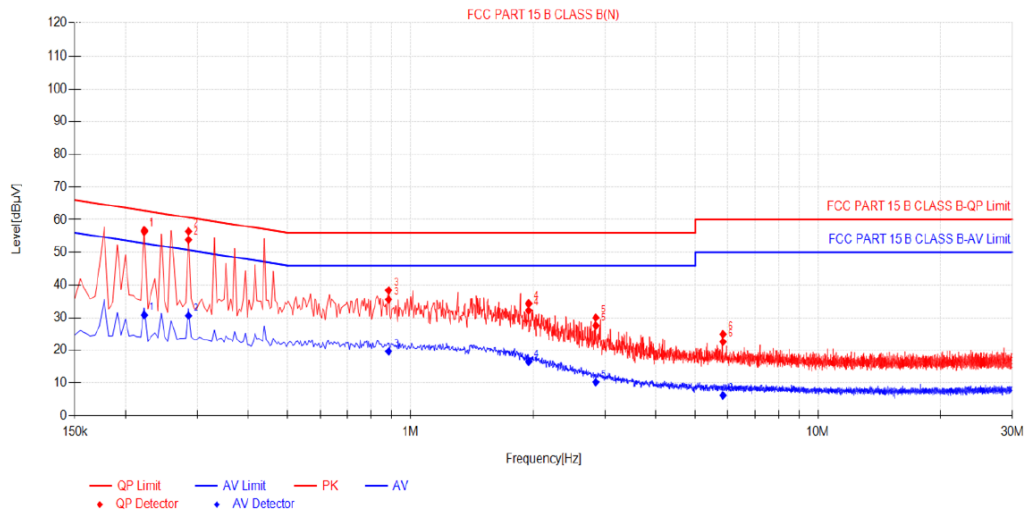

Final Data List

NO.	Freq. [MHz]	Factor [dB]	QP Reading[dB µV]	QP Value [dBµV]	QP Limit [dBµV]	QP Margin [dB]	AV Reading [dBµV]	AV Value [dBµV]	AV Limit [dBµV]	AV Margin [dB]	Verdict
1	0.222	9.98	46.73	56.71	62.74	6.03	20.82	30.80	52.74	21.94	PASS
2	0.285	9.91	43.89	53.80	60.67	6.87	20.70	30.61	50.67	20.06	PASS
3	0.8835	10.13	25.43	35.56	56.00	20.44	9.56	19.69	46.00	26.31	PASS
4	1.95	10.19	22.02	32.21	56.00	23.79	6.30	16.49	46.00	29.51	PASS
5	2.85	10.21	17.37	27.58	56.00	28.42	0.02	10.23	46.00	35.77	PASS
6	5.847	10.23	12.35	22.58	60.00	37.42	-4.05	6.18	50.00	43.82	PASS

- Note:1). QP Value (dBµV) = QP Reading (dBµV) + Factor (dB)
 2). Factor (dB) = insertion loss of LISN (dB) + Cable loss (dB)
 3). QP Margin (dB) = QP Limit (dBµV) - QP Value (dBµV)
 4). AV Margin (dB) = AV Limit (dBµV) - AV Value (dBµV)

Test Frequency:	912MHz	Polarization	L
-----------------	--------	--------------	---

Test Graph

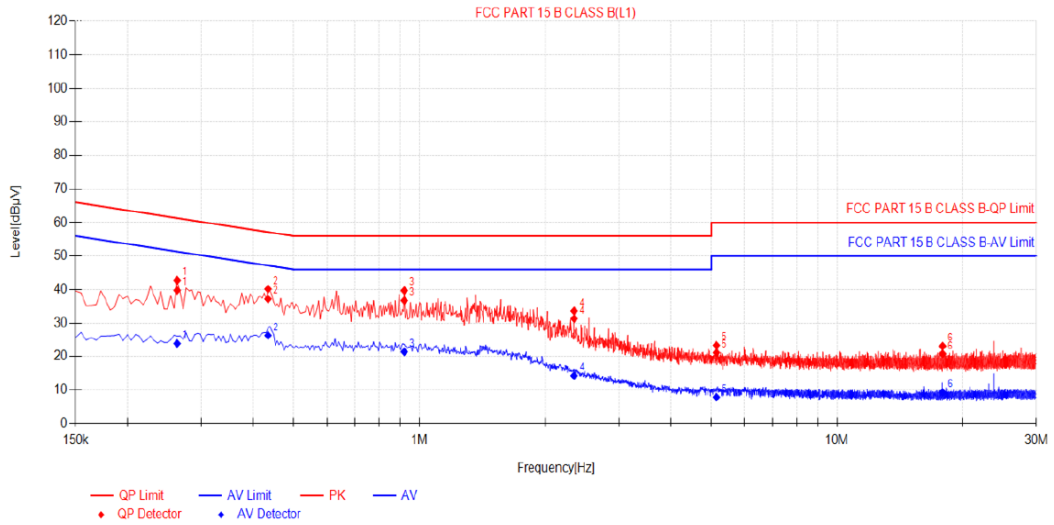

Final Data List

NO.	Freq. [MHz]	Factor [dB]	QP Reading[dB µV]	QP Value [dBµV]	QP Limit [dBµV]	QP Margin [dB]	AV Reading [dBµV]	AV Value [dBµV]	AV Limit [dBµV]	AV Margin [dB]	Verdict
1	0.2625	9.94	29.82	39.76	61.35	21.59	13.97	23.91	51.35	27.44	PASS
2	0.4335	9.92	27.27	37.19	57.19	20.00	16.43	26.35	47.19	20.84	PASS
3	0.9195	10.00	26.73	36.73	56.00	19.27	11.44	21.44	46.00	24.56	PASS
4	2.346	10.05	21.27	31.32	56.00	24.68	4.24	14.29	46.00	31.71	PASS
5	5.1405	10.01	11.18	21.19	60.00	38.81	-2.12	7.89	50.00	42.11	PASS
6	17.898	10.37	10.44	20.81	60.00	39.19	-1.07	9.30	50.00	40.70	PASS

Note:1).QP Value (dBµV)= QP Reading (dBµV)+ Factor (dB)

2). Factor (dB)=insertion loss of LISN (dB) + Cable loss (dB)

3). QPMargin(dB) = QP Limit (dBµV) - QP Value (dBµV)

4). AVMargin(dB) = AV Limit (dBµV) - AV Value (dBµV)

Test Frequency:	912MHz	Polarization	N
-----------------	--------	--------------	---

Test Graph

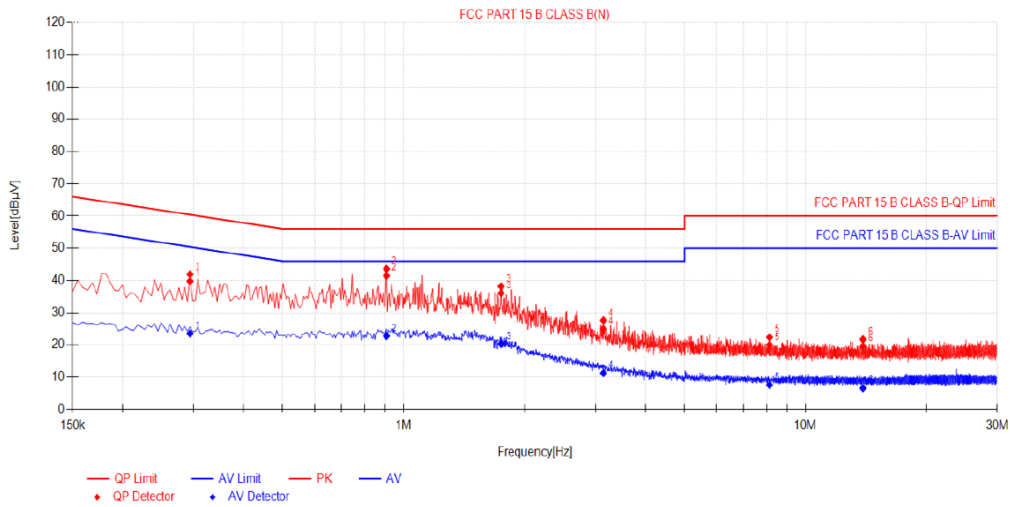

Final Data List

NO.	Freq. [MHz]	Factor [dB]	QP Reading[dBµV]	QP Value [dBµV]	QP Limit [dBµV]	QP Margin [dB]	AV Reading [dBµV]	AV Value [dBµV]	AV Limit [dBµV]	AV Margin [dB]	Verdict
1	0.294	9.88	29.92	39.80	60.41	20.61	13.64	23.52	50.41	26.89	PASS
2	0.906	10.13	31.33	41.46	56.00	14.54	12.64	22.77	46.00	23.23	PASS
3	1.7475	10.16	25.89	36.05	56.00	19.95	10.14	20.30	46.00	25.70	PASS
4	3.1425	10.23	14.67	24.90	56.00	31.10	1.02	11.25	46.00	34.75	PASS
5	8.1375	10.42	9.63	20.05	60.00	39.95	-2.84	7.58	50.00	42.42	PASS
6	13.902	10.42	9.18	19.60	60.00	40.40	-3.85	6.57	50.00	43.43	PASS

- Note:1).QP Value (dBµV)= QP Reading (dBµV)+ Factor (dB)
 2). Factor (dB)=insertion loss of LISN (dB) + Cable loss (dB)
 3). QPMargin(dB) = QP Limit (dBµV) - QP Value (dBµV)
 4). AVMargin(dB) = AV Limit (dBµV) - AV Value (dBµV)

Test Frequency:	920.00MHz	Polarization	L
-----------------	-----------	--------------	---

Test Graph

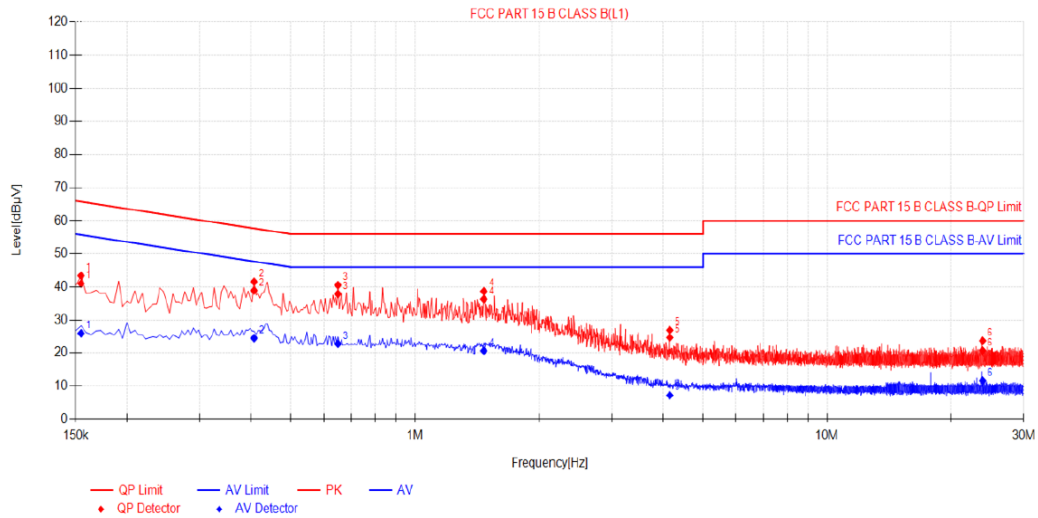

Final Data List

NO.	Freq. [MHz]	Factor [dB]	QP Reading[dBµV]	QP Value [dBµV]	QP Limit [dBµV]	QP Margin [dB]	AV Reading [dBµV]	AV Value [dBµV]	AV Limit [dBµV]	AV Margin [dB]	Verdict
1	0.1545	9.89	31.16	41.05	65.75	24.70	16.08	25.97	55.75	29.78	PASS
2	0.4065	9.88	29.05	38.93	57.72	18.79	14.64	24.52	47.72	23.20	PASS
3	0.6495	9.98	27.92	37.90	56.00	18.10	12.81	22.79	46.00	23.21	PASS
4	1.4685	9.90	26.44	36.34	56.00	19.66	10.78	20.68	46.00	25.32	PASS
5	4.1505	9.93	14.75	24.68	56.00	31.32	-2.70	7.23	46.00	38.77	PASS
6	23.8605	10.49	10.25	20.74	60.00	39.26	1.13	11.62	50.00	38.38	PASS

- Note:1).QP Value (dBµV)= QP Reading (dBµV)+ Factor (dB)
 2). Factor (dB)=insertion loss of LISN (dB) + Cable loss (dB)
 3). QPMargin(dB) = QP Limit (dBµV) - QP Value (dBµV)
 4). AVMargin(dB) = AV Limit (dBµV) - AV Value (dBµV)

Test Frequency:	920.00MHz	Polarization	N
-----------------	-----------	--------------	---

Test Graph

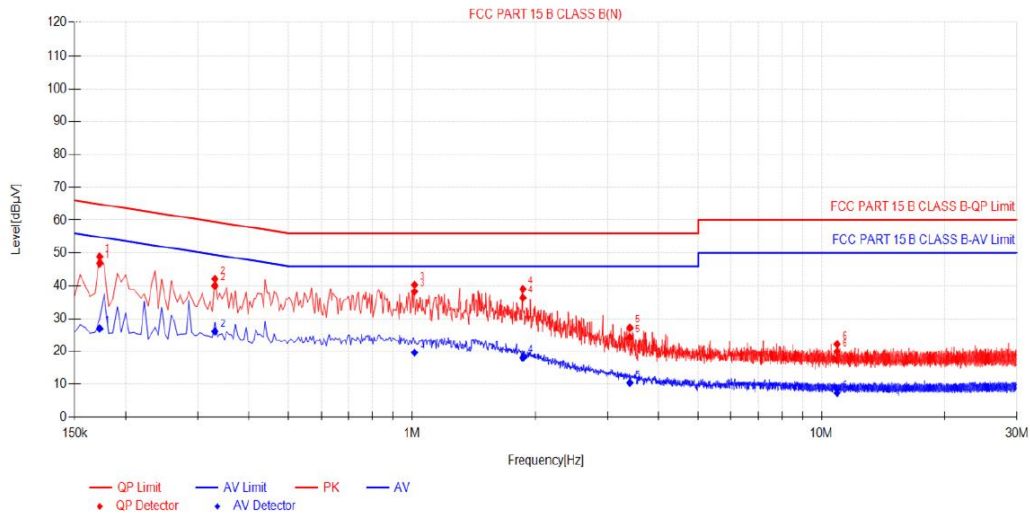

Final Data List

NO.	Freq. [MHz]	Factor [dB]	QP Reading[dB μV]	QP Value [dBμV]	QP Limit [dBμV]	QP Margin [dB]	AV Reading [dBμV]	AV Value [dBμV]	AV Limit [dBμV]	AV Margin [dB]	Verdict
1	0.1725	10.07	36.77	46.84	64.84	18.00	16.88	26.95	54.84	27.89	PASS
2	0.33	9.86	30.17	40.03	59.45	19.42	16.23	26.09	49.45	23.36	PASS
3	1.014	10.12	28.12	38.24	56.00	17.76	9.53	19.65	46.00	26.35	PASS
4	1.8645	10.18	26.17	36.35	56.00	19.65	7.92	18.10	46.00	27.90	PASS
5	3.4035	10.19	14.02	24.21	56.00	31.79	0.25	10.44	46.00	35.56	PASS
6	10.9185	10.40	9.61	20.01	60.00	39.99	-3.07	7.33	50.00	42.67	PASS

- Note:1).QP Value (dBμV)= QP Reading (dBμV)+ Factor (dB)
 2). Factor (dB)=insertion loss of LISN (dB) + Cable loss (dB)
 3). QP Margin(dB) = QP Limit (dBμV) - QP Value (dBμV)
 4). AV Margin(dB) = AV Limit (dBμV) - AV Value (dBμV)

4.2 Radiated Emissions and Band Edge

Limit

According to 15.249 and RSS-210 Annex B.10, the field strength of emissions from intentional radiators operated within 902MHz-928 MHz shall not exceed 94dB μ V/m (50mV/m):

FCC PART 15.249(d) and RSS-210 Annex B.10, Emissions radiated outside of the specified frequency bands, except for harmonics, shall be attenuated by at least 50 dB below the level of the fundamental or to the general radiated emission limits list as below, whichever is the lesser attenuation.

In addition, radiated emissions which fall in the restricted bands, must also comply with the radiated emission limits specified list as below.

Radiated emission limits

Frequency (MHz)	Distance (Meters)	Radiated (dB μ V/m)	Radiated (μ V/m)
0.009-0.49	3	$20\log(2400/F(\text{KHz}))+40\log(300/3)$	$2400/F(\text{KHz})$
0.49-1.705	3	$20\log(24000/F(\text{KHz}))+40\log(30/3)$	$24000/F(\text{KHz})$
1.705-30	3	$20\log(30)+40\log(30/3)$	30
30-88	3	40.0	100
88-216	3	43.5	150
216-960	3	46.0	200
Above 960	3	54.0	500

TEST CONFIGURATION

(A) Radiated Emission Test Set-Up, Frequency Below 30MHz

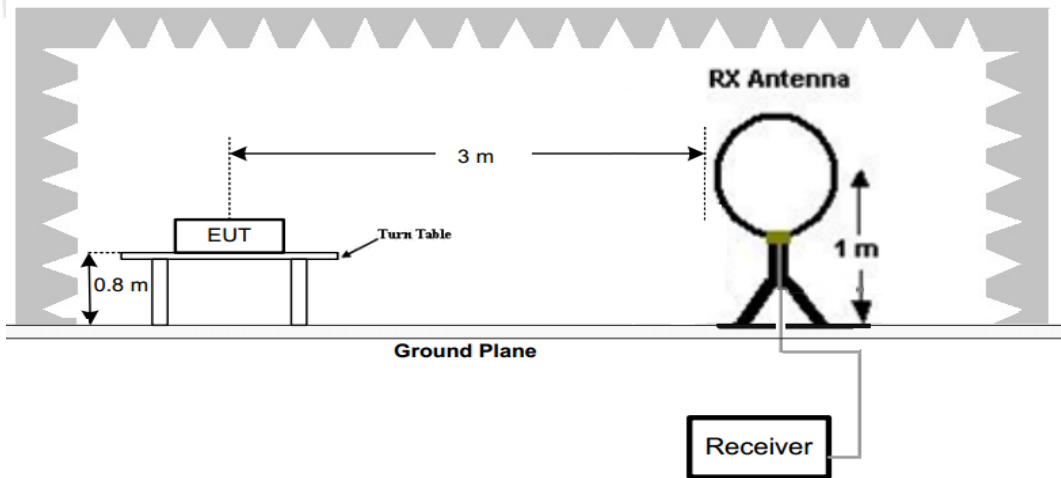

(B) Radiated Emission Test Set-Up, Frequency below 1000MHz

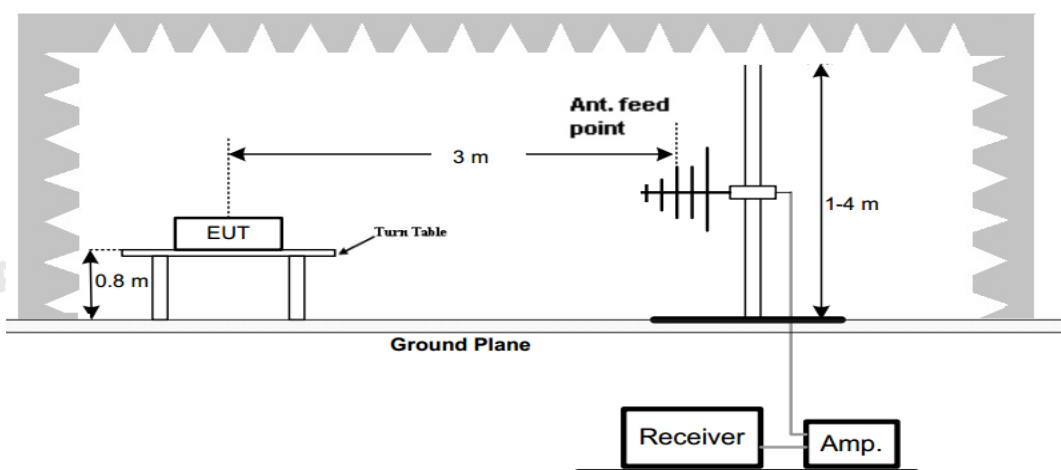

(C) Radiated Emission Test Set-Up, Frequency above 1000MHz

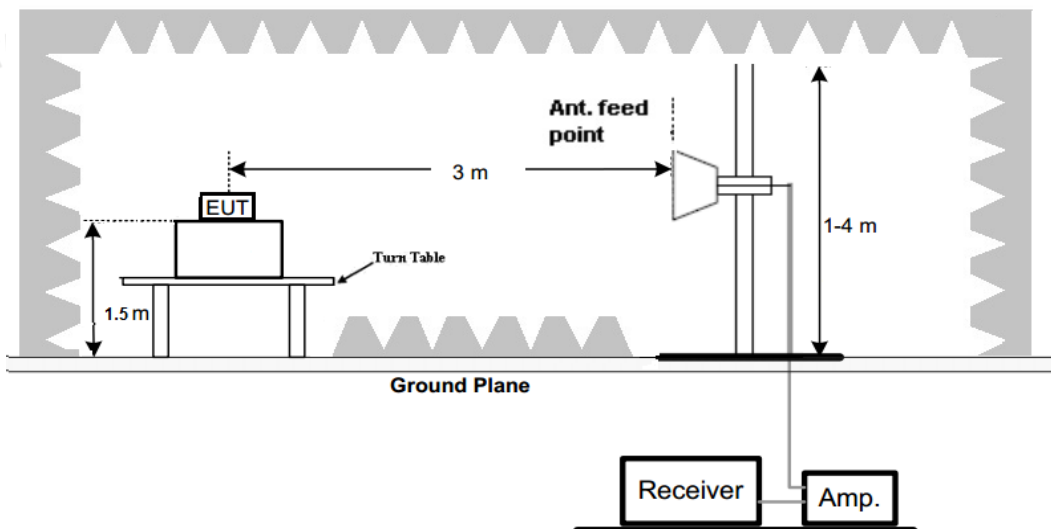

Test Procedure

- Below 1GHz measurement the EUT is placed on a turntable which is 0.8m above ground plane, and above 1GHz measurement EUT was placed on a low permittivity and low loss tangent turn table which is 1.5m above ground plane.
- Maximum procedure was performed by raising the receiving antenna from 1m to 4m and rotating the turn table from 0° to 360° to acquire the highest emissions from EUT
- And also, each emission was to be maximized by changing the polarization of receiving antenna both horizontal and vertical.
- Repeat above procedures until all frequency measurements have been completed.
- Radiated emission test frequency band from 9KHz to 10GHz.
- The distance between test antenna and EUT as following table states:

Test Frequency range	Test Antenna Type	Test Distance
9KHz-30MHz	Active Loop Antenna	3
30MHz-1GHz	Bilog Antenna	3
1GHz-10GHz	Horn Antenna	3

- Setting test receiver/spectrum as following table states:

Test Frequency range	Test Receiver/Spectrum Setting	Detector
9KHz-150KHz	RBW=200Hz/VBW=3KHz, Sweep time=Auto	QP
150KHz-30MHz	RBW=9KHz/VBW=100KHz, Sweep time=Auto	QP
30MHz-1GHz	RBW=120KHz/VBW=1000KHz, Sweep time=Auto	QP
1GHz-10GHz	Peak Value: RBW=1MHz/VBW=3MHz, Sweep time=Auto Average Value: RBW=1MHz/VBW=10Hz, Sweep time=Auto	Peak

TEST RESULTS

Remark:

- Radiated emission test from 9 KHz to 10th harmonic of fundamental was verified, and no emission found except system noise floor in 9 KHz to 30MHz and not recorded in this report.

For 30MHz-1GHz

Test Frequency:	908.42MHz	Polarization:	Horizontal
-----------------	-----------	---------------	------------

Test Graph

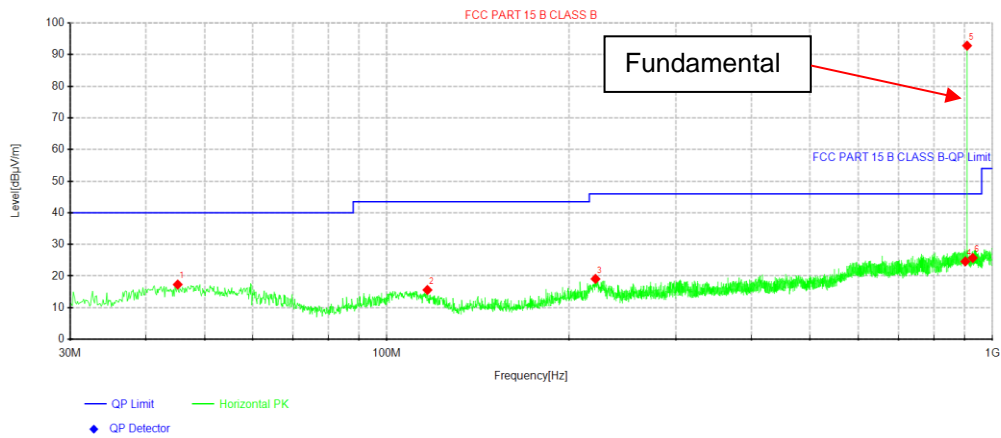

Suspected List											
NO.	Frequency [MHz]	Reading (dBµV/m)	Factor [dB]	Result [dB µ V/m]	Limit [dB µ V/m]	Margin [dB]	Height [cm]	Angle [°]	Detector	Polarity	Remark
1	45.1562	29.04	-11.73	17.31	40.00	22.69	100	3	PK	Horizontal	Pass
2	116.6938	29.70	-14.11	15.59	43.50	27.91	100	177	PK	Horizontal	Pass
3	221.090	32.14	-13.05	19.09	46.00	26.91	100	291	PK	Horizontal	Pass
4	902.000	26.89	-2.28	24.61	46.00	21.39	100	65	PK	Horizontal	Pass
5	908.420	95.06	-2.23	92.83	114.00	21.17	100	279	PK	Horizontal	Pass
5	908.420	89.92	-2.23	87.69	94.00	6.31	100	279	QP	Horizontal	Pass
5	908.420	89.57	-2.23	87.34	94.00	6.66	100	279	AV	Horizontal	Pass
6	928.000	27.80	-2.08	25.72	46.00	20.28	100	258	PK	Horizontal	Pass

Test Frequency:	908.42MHz	Polarization:	Vertical
-----------------	-----------	---------------	----------

Test Graph

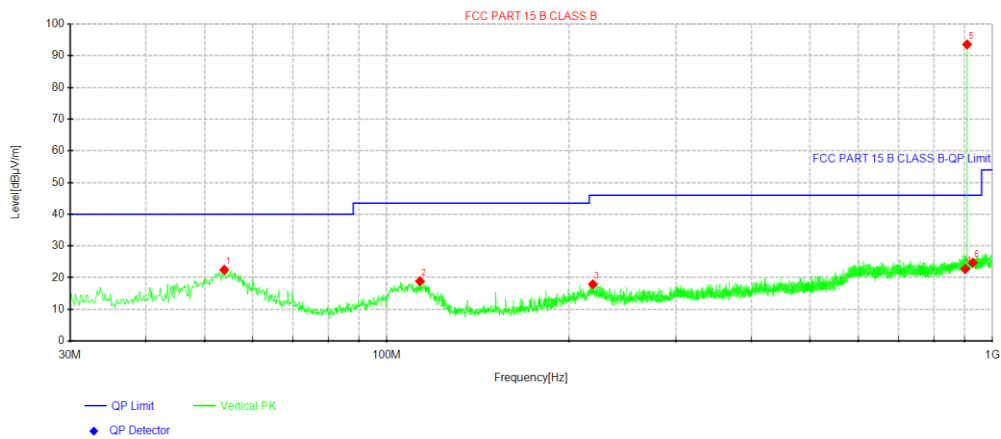

Suspected List											
NO.	Frequency [MHz]	Reading (dBµV/m)	Factor [dB]	Result [dB µ V/m]	Limit [dB µ V/m]	Margin [dB]	Height [cm]	Angle [°]	Detector	Polarity	Remark
1	53.8862	34.29	-11.82	22.47	40.00	17.53	100	0	PK	Vertical	Pass
2	113.420	32.79	-13.93	18.86	43.50	24.64	100	360	PK	Vertical	Pass
3	218.9075	31.01	-13.10	17.91	46.00	28.09	100	86	PK	Vertical	Pass
4	902.000	25.02	-2.28	22.74	46.00	23.26	100	1	PK	Vertical	Pass
5	908.420	95.80	-2.23	93.57	114.00	20.43	100	158	PK	Vertical	Pass
5	908.420	90.55	-2.23	88.32	94.00	5.68	100	158	QP	Vertical	Pass
5	908.420	90.38	-2.23	88.15	94.00	5.85	100	158	AV	Vertical	Pass
6	928.000	26.78	-2.08	24.70	46.00	21.30	100	327	PK	Vertical	Pass

Note: Result (dBµV/m) = Reading (dBµV/m) + Factor (dB) .
 Factor (dB) = Antenna Factor (dB/m) + Cable loss (dB) - Pre Amplifier gain (dB).
 Margin = Limit (dBµV/m) - Result (dBµV/m)

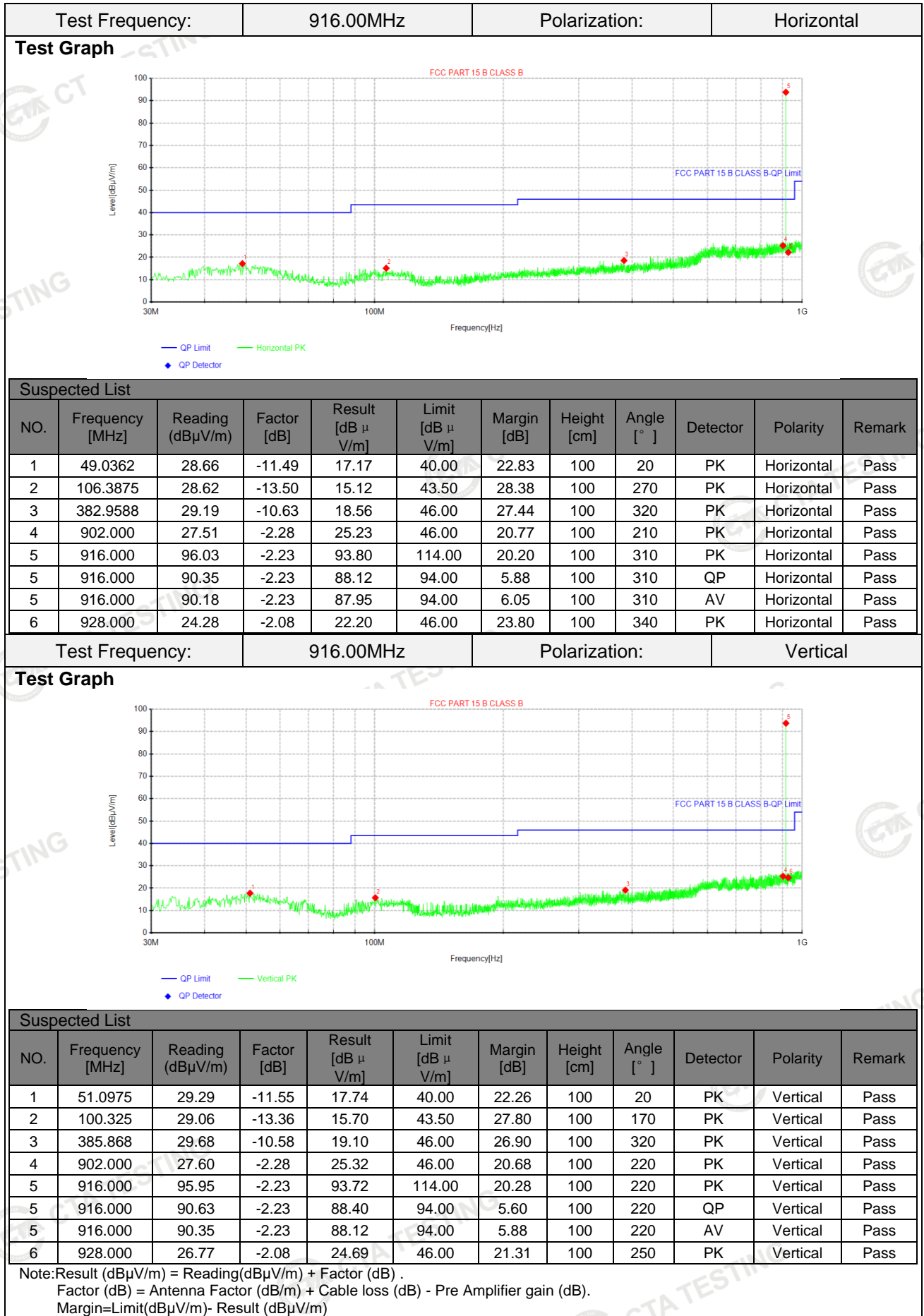

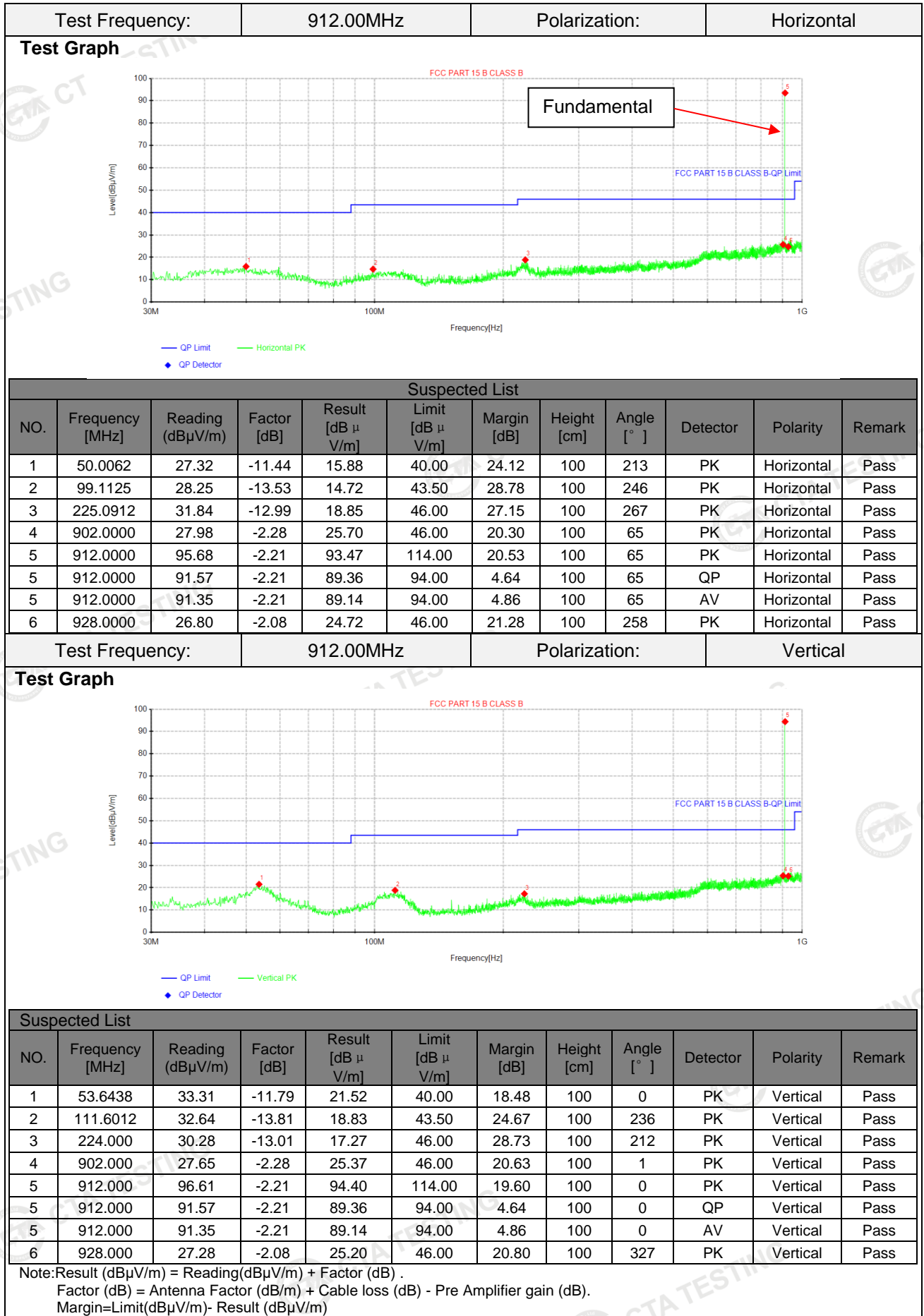

Test Frequency:	920.00MHz	Polarization:	Horizontal
-----------------	-----------	---------------	------------

Test Graph

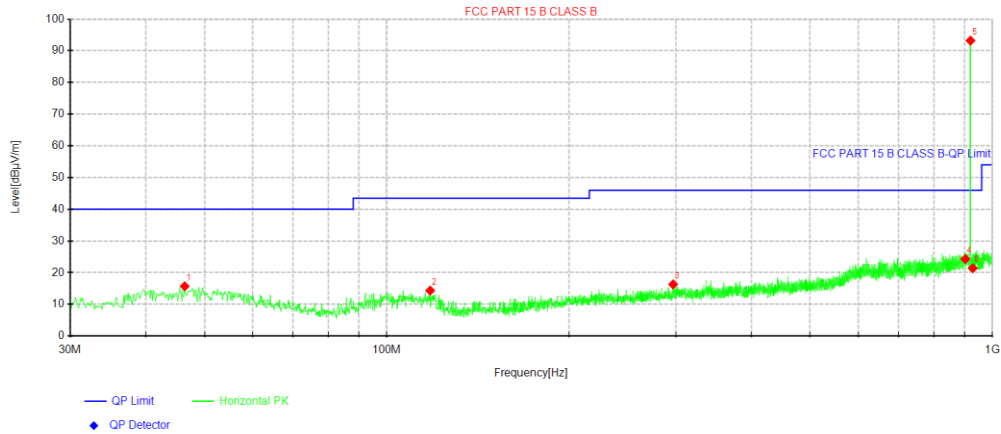

Suspected List											
NO.	Frequency [MHz]	Reading (dBµV/m)	Factor [dB]	Result [dB µV/m]	Limit [dB µV/m]	Margin [dB]	Height [cm]	Angle [°]	Detector	Polarity	Remark
1	46.3688	27.36	-11.65	15.71	40.00	24.29	100	150	PK	Horizontal	Pass
2	117.9062	28.51	-14.17	14.34	43.50	29.16	100	20	PK	Horizontal	Pass
3	296.9925	27.79	-11.49	16.30	46.00	29.70	100	270	PK	Horizontal	Pass
4	902.000	26.57	-2.28	24.29	46.00	21.71	100	210	PK	Horizontal	Pass
5	920.000	95.44	-2.24	93.20	114.00	20.80	100	320	PK	Horizontal	Pass
5	920.000	90.79	-2.24	88.55	94.00	5.45	100	320	QP	Horizontal	Pass
5	920.000	90.60	-2.24	88.36	94.00	5.64	100	320	AV	Horizontal	Pass
6	928.000	23.48	-2.08	21.40	46.00	24.60	100	340	PK	Horizontal	Pass

Test Frequency:	920.00MHz	Polarization:	Vertical
-----------------	-----------	---------------	----------

Test Graph

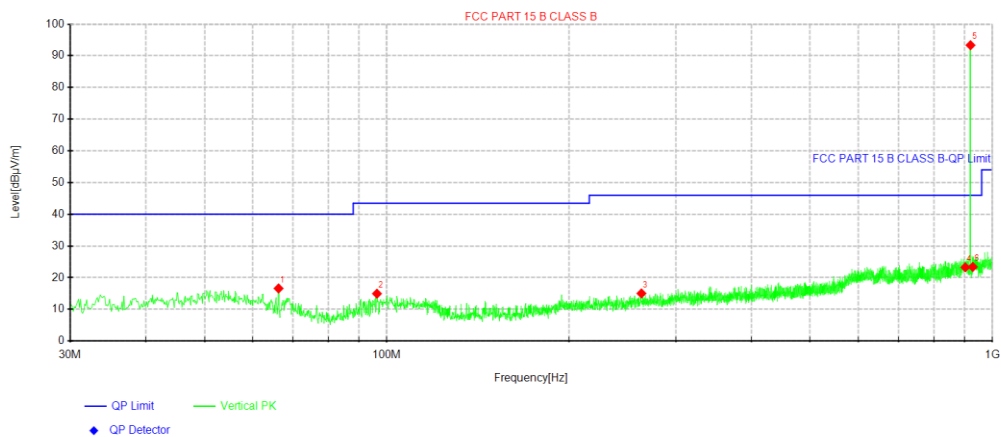

Suspected List											
NO.	Frequency [MHz]	Reading (dBµV/m)	Factor [dB]	Result [dB µV/m]	Limit [dB µV/m]	Margin [dB]	Height [cm]	Angle [°]	Detector	Polarity	Remark
1	66.2538	31.04	-14.44	16.60	40.00	23.40	100	40	PK	Vertical	Pass
2	96.3238	29.04	-14.10	14.94	43.50	28.56	100	10	PK	Vertical	Pass
3	263.285	27.37	-12.35	15.02	46.00	30.98	100	190	PK	Vertical	Pass
4	902.000	25.55	-2.28	23.27	46.00	22.73	100	220	PK	Vertical	Pass
5	920.000	95.57	-2.24	93.33	114.00	20.67	100	250	PK	Vertical	Pass
5	920.000	90.98	-2.24	88.74	94.00	5.26	100	250	QP	Vertical	Pass
5	920.000	90.89	-2.24	88.65	94.00	5.35	100	250	AV	Vertical	Pass
6	928.000	25.47	-2.08	23.39	46.00	22.61	100	250	PK	Vertical	Pass

Note: Result (dBµV/m) = Reading(dBµV/m) + Factor (dB) .
 Factor (dB) = Antenna Factor (dB/m) + Cable loss (dB) - Pre Amplifier gain (dB).
 Margin=Limit(dBµV/m)- Result (dBµV/m)

For 1GHz to 25GHz

Frequency (MHz):				908.42		Polarity:			HORIZONTAL	
No.	Frequency (MHz)	Emission Level (dBuV/m)		Limit (dBuV/m)	Margin (dB)	Raw Value (dBuV)	Antenna Factor (dB/m)	Cable Factor (dB)	Pre-amplifier (dB)	Correction Factor (dB/m)
1	1816.84	55.26	PK	74.00	18.74	65.41	27.24	4.03	41.42	-10.15
1	1816.84	46.94	AV	54.00	7.06	57.09	27.24	4.03	41.42	-10.15
2	2725.26	47.89	PK	74.00	26.11	55.13	29.4	4.96	41.6	-7.24
2	2725.26	--	AV	54.00	--	--	--	--	--	--
3	3633.68	50.25	PK	74.00	23.75	54.31	32.24	5.63	41.93	-4.06
3	3633.68	--	AV	54.00	--	--	--	--	--	--

Frequency(MHz):				908.42		Polarity:			VERTICAL	
No.	Frequency (MHz)	Emission Level (dBuV/m)		Limit (dBuV/m)	Margin (dB)	Raw Value (dBuV)	Antenna Factor (dB/m)	Cable Factor (dB)	Pre-amplifier (dB)	Correction Factor (dB/m)
1	1816.84	56.47	PK	74.00	17.53	66.62	27.24	4.03	41.42	-10.15
1	1816.84	48.08	AV	54.00	5.92	58.23	27.24	4.03	41.42	-10.15
2	2725.26	49.07	PK	74.00	24.93	56.31	29.4	4.96	41.6	-7.24
2	2725.26	--	AV	54.00	--	--	--	--	--	--
3	3633.68	51.28	PK	74.00	22.72	55.34	32.24	5.63	41.93	-4.06
3	3633.68	--	AV	54.00	--	--	--	--	--	--

REMARKS:

1. Emission level (dBuV/m) =Raw Value (dBuV)+Correction Factor (dB/m)
2. Correction Factor (dB/m) = Antenna Factor (dB/m)+Cable Factor (dB)-Pre-amplifier Factor
3. Margin value = Limit value- Emission level.
4. -- Mean the PK detector measured value is below average limit.
5. The other emission levels were very low against the limit.
6. RBW1MHz VBW3MHz Peak detector is for PK value; RBW 1MHz VBW10Hz Peak detector is for AV value.

Frequency(MHz):				916.00		Polarity:			HORIZONTAL	
No.	Frequency (MHz)	Emission Level (dBuV/m)		Limit (dBuV/m)	Margin (dB)	Raw Value (dBuV)	Antenna Factor (dB/m)	Cable Factor (dB)	Pre-amplifier (dB)	Correction Factor (dB/m)
1	1832.00	54.10	PK	74.00	19.90	64.18	27.3	4.04	41.42	-10.08
1	1832.00	45.02	AV	54.00	8.98	55.10	27.3	4.04	41.42	-10.08
2	2748.00	46.00	PK	74.00	28.00	53.16	29.47	4.98	41.61	-7.16
2	2748.00	--	AV	54.00	--	--	--	--	--	--
3	3664.00	49.14	PK	74.00	24.86	53.27	32.39	5.42	41.94	-4.13
3	3664.00	--	AV	54.00	--	--	--	--	--	--

Frequency(MHz):				916.00		Polarity:			VERTICAL	
No.	Frequency (MHz)	Emission Level (dBuV/m)		Limit (dBuV/m)	Margin (dB)	Raw Value (dBuV)	Antenna Factor (dB/m)	Cable Factor (dB)	Pre-amplifier (dB)	Correction Factor (dB/m)
1	1832.00	55.69	PK	74.00	18.31	65.77	27.3	4.04	41.42	-10.08
1	1832.00	47.25	AV	54.00	6.75	57.33	27.3	4.04	41.42	-10.08
2	2748.00	48.07	PK	74.00	25.93	55.23	29.47	4.98	41.61	-7.16
2	2748.00	--	AV	54.00	--	--	--	--	--	--
3	3664.00	50.64	PK	74.00	23.36	54.77	32.39	5.42	41.94	-4.13
3	3664.00	--	AV	54.00	--	--	--	--	--	--

REMARKS:

1. Emission level (dBuV/m) = Raw Value (dBuV) + Correction Factor (dB/m)
2. Correction Factor (dB/m) = Antenna Factor (dB/m) + Cable Factor (dB) - Pre-amplifier Factor
3. Margin value = Limit value - Emission level.
4. -- Mean the PK detector measured value is below average limit.
5. The other emission levels were very low against the limit.
6. RBW1MHz VBW3MHz Peak detector is for PK value; RBW 1MHz VBW10Hz Peak detector is for AV value.

Frequency (MHz):				912.00		Polarity:			HORIZONTAL	
No.	Frequency (MHz)	Emission Level (dBuV/m)		Limit (dBuV/m)	Margin (dB)	Raw Value (dBuV)	Antenna Factor (dB/m)	Cable Factor (dB)	Pre-amplifier (dB)	Correction Factor (dB/m)
1	1824.00	55.08	PK	74.00	18.92	65.10	27.33	4.08	41.43	-10.02
1	1824.00	47.65	AV	54.00	6.35	57.70	27.33	4.06	41.44	-10.05
2	2736.00	47.77	PK	74.00	26.23	54.93	29.47	4.99	41.62	-7.16
2	2736.00	--	AV	54.00	--	--	--	--	--	--
3	3648.00	50.15	PK	74.00	23.85	54.21	32.43	5.46	41.95	-4.06
3	3648.00	--	AV	54.00	--	--	--	--	--	--

Frequency(MHz):				912.00		Polarity:			VERTICAL	
No.	Frequency (MHz)	Emission Level (dBuV/m)		Limit (dBuV/m)	Margin (dB)	Raw Value (dBuV)	Antenna Factor (dB/m)	Cable Factor (dB)	Pre-amplifier (dB)	Correction Factor (dB/m)
1	1824.00	56.80	PK	74.00	17.20	66.82	27.33	4.08	41.43	-10.02
1	1824.00	47.83	AV	54.00	6.17	57.88	27.33	4.06	41.44	-10.05
2	2736.00	48.86	PK	74.00	25.14	56.02	29.47	4.99	41.62	-7.16
2	2736.00	--	AV	54.00	--	--	--	--	--	--
3	3648.00	50.99	PK	74.00	23.01	55.05	32.43	5.46	41.95	-4.06
3	3648.00	--	AV	54.00	--	--	--	--	--	--

REMARKS:

1. Emission level (dBuV/m) = Raw Value (dBuV) + Correction Factor (dB/m)
2. Correction Factor (dB/m) = Antenna Factor (dB/m) + Cable Factor (dB) - Pre-amplifier Factor
3. Margin value = Limit value - Emission level.
4. -- Mean the PK detector measured value is below average limit.
5. The other emission levels were very low against the limit.
6. RBW1MHz VBW3MHz Peak detector is for PK value; RBW 1MHz VBW10Hz Peak detector is for AV value.

Frequency(MHz):				920.00		Polarity:			HORIZONTAL	
No.	Frequency (MHz)	Emission Level (dBuV/m)		Limit (dBuV/m)	Margin (dB)	Raw Value (dBuV)	Antenna Factor (dB/m)	Cable Factor (dB)	Pre-amplifier (dB)	Correction Factor (dB/m)
1	1840.00	54.07	PK	74.00	19.93	64.03	27.37	4.12	41.45	-9.96
1	1840.00	44.98	AV	54.00	9.02	54.98	27.36	4.1	41.46	-10.00
2	2760.00	46.57	PK	74.00	27.43	53.68	29.5	5.03	41.64	-7.11
2	2760.00	--	AV	54.00	--	--	--	--	--	--
3	3680.00	49.27	PK	74.00	24.73	53.36	32.44	5.46	41.99	-4.09
3	3680.00	--	AV	54.00	--	--	--	--	--	--

Frequency(MHz):				920.00		Polarity:			VERTICAL	
No.	Frequency (MHz)	Emission Level (dBuV/m)		Limit (dBuV/m)	Margin (dB)	Raw Value (dBuV)	Antenna Factor (dB/m)	Cable Factor (dB)	Pre-amplifier (dB)	Correction Factor (dB/m)
1	1840.00	55.75	PK	74.00	18.25	65.71	27.37	4.12	41.45	-9.96
1	1840.00	47.08	AV	54.00	6.92	57.08	27.36	4.1	41.46	-10.00
2	2760.00	48.50	PK	74.00	25.50	55.61	29.5	5.03	41.64	-7.11
2	2760.00	--	AV	54.00	--	--	--	--	--	--
3	3680.00	50.37	PK	74.00	23.63	54.46	32.44	5.46	41.99	-4.09
3	3680.00	--	AV	54.00	--	--	--	--	--	--

REMARKS:

1. Emission level (dBuV/m) = Raw Value (dBuV) + Correction Factor (dB/m)
2. Correction Factor (dB/m) = Antenna Factor (dB/m) + Cable Factor (dB) - Pre-amplifier Factor
3. Margin value = Limit value - Emission level.
4. -- Mean the PK detector measured value is below average limit.
5. The other emission levels were very low against the limit.
6. RBW1MHz VBW3MHz Peak detector is for PK value; RBW 1MHz VBW10Hz Peak detector is for AV value.

4.3 Occupied Bandwidth Measurement

Limit

N/A

Test Configuration

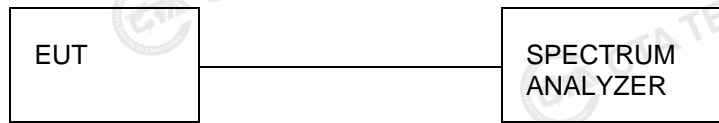

Test Procedure

The 20dB bandwidth and 99% bandwidth is measured with a spectrum analyzer connected via a receive antenna placed near the EUT while the EUT is operating in transmission mode.

The 20dB bandwidth is defined as the total spectrum the power of which is higher than peak power minus 20dB.

The occupied bandwidth (OBW), that is the frequency bandwidth such that, below its lower and above its upper frequency limits, the mean powers radiated are each equal to 0.5 percent of the total mean power radiated by a given emission.

Test Results

Modulation	Frequency (MHz)	99% OBW (KHz)	20dB bandwidth (KHz)	Result
FSK/ GFSK	908.42	129.42	152.5	Pass
	916.00	146.19	176.6	
DSSS-OQPSK	912.00	923.22	1042	
	920.00	922.42	1043	

Test plot as follows:

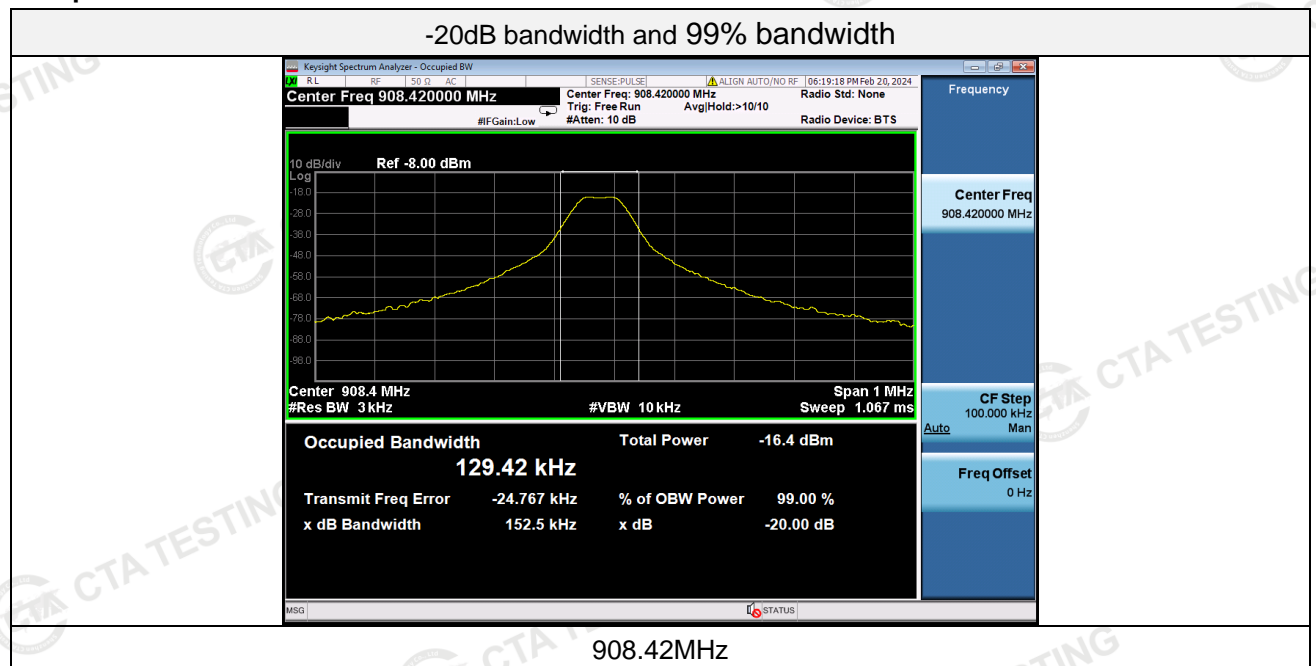

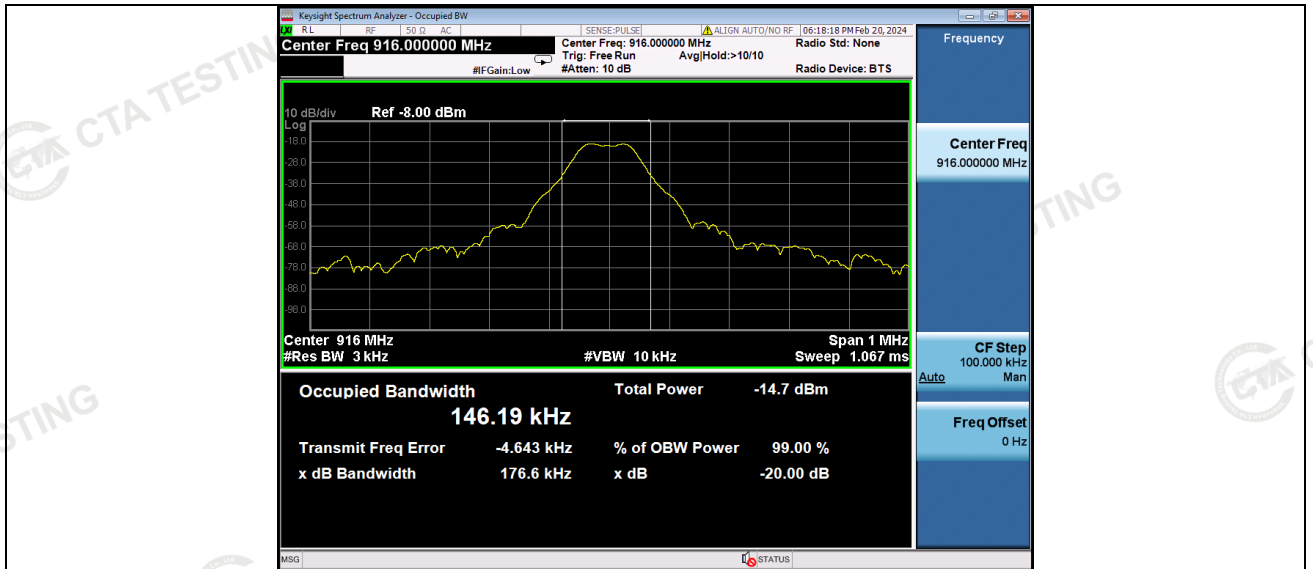

916.00MHz

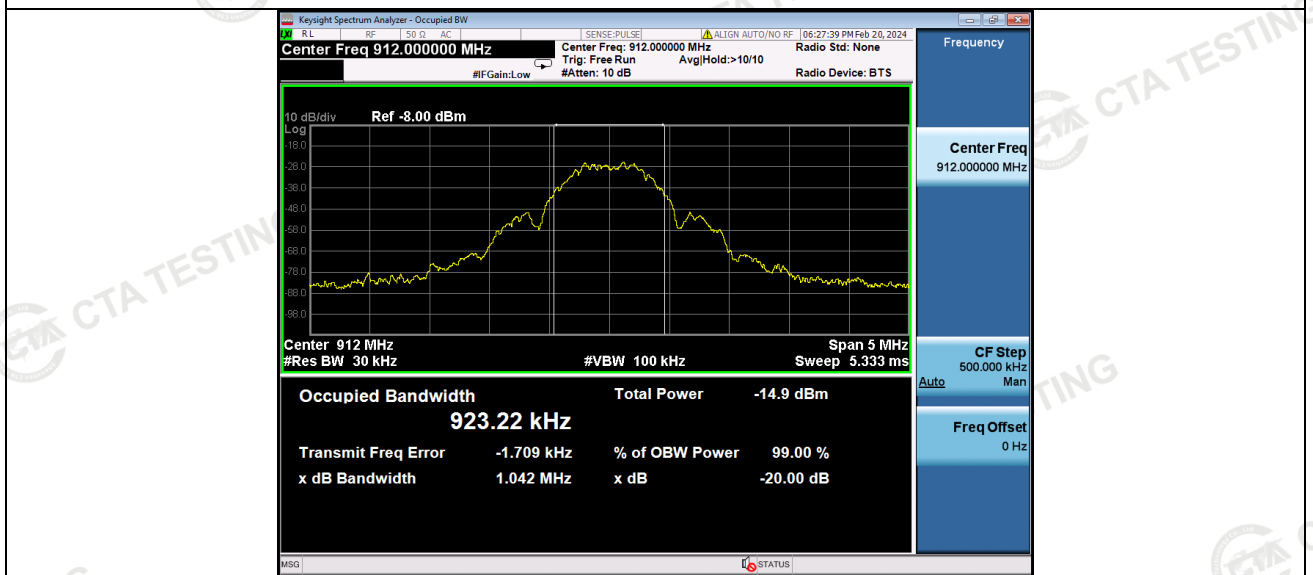

912.00MHz

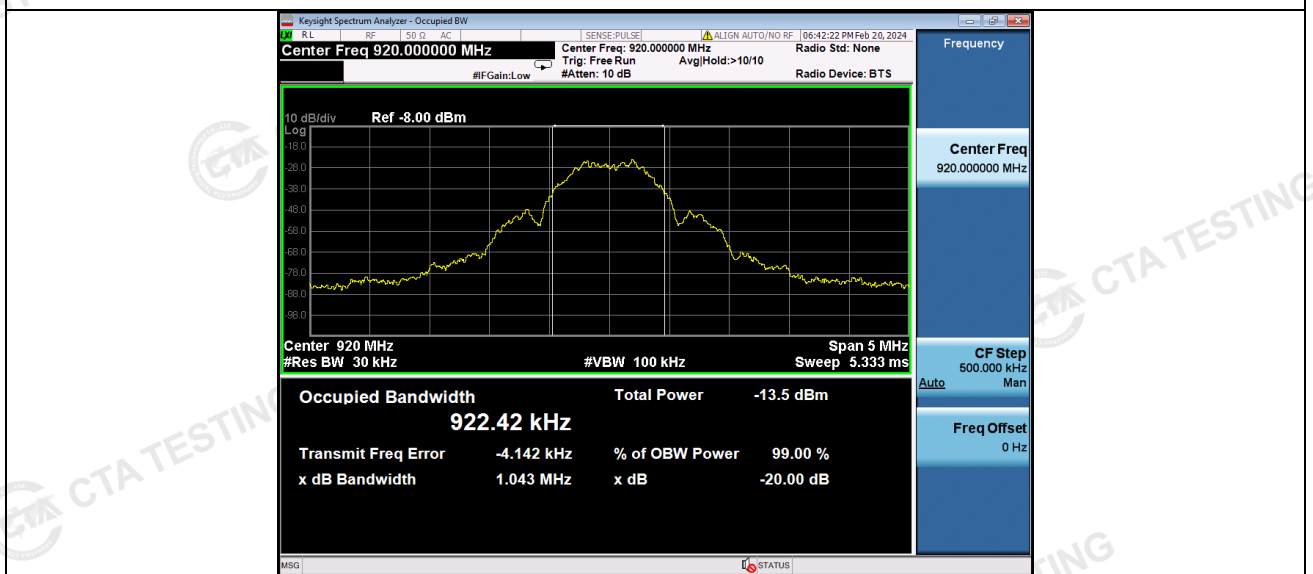

920.00MHz

4.4 Antenna Requirement

Standard Applicable

FCC 47 CFR Section 15.203

For intentional device, according to FCC 47 CFR Section 15.203, an intentional radiator shall be designed to ensure that no antenna other than that furnished by the responsible party shall be used with the device.

RSS-Gen

The applicant for equipment certification shall provide a list of all antenna types that may be used with the transmitter, where applicable (i.e. for transmitters with detachable antenna), indicating the maximum permissible antenna gain (in dBi) and the required impedance for each antenna. The test report shall demonstrate the compliance of the transmitter with the limit for maximum equivalent isotropically radiated power (e.i.r.p.) specified in the applicable RSS, when the transmitter is equipped with any antenna type, selected from this list.

For expediting the testing, measurements may be performed using only the antenna with highest gain of each combination of transmitter and antenna type, with the transmitter output power set at the maximum level. However, the transmitter shall comply with the applicable requirements under all operational conditions and when in combination with any type of antenna from the list provided in the test report (and in the notice to be included in the user manual, provided below).

When measurements at the antenna port are used to determine the RF output power, the effective gain of the device's antenna shall be stated, based on a measurement or on data from the antenna's manufacturer.

The test report shall state the RF power, output power setting and spurious emission measurements with each antenna type that is used with the transmitter being tested.

For licence-exempt equipment with detachable antennas, the user manual shall also contain the following notice in a conspicuous location:

This radio transmitter [enter the device's ISED certification number] has been approved by Innovation, Science and Economic Development Canada to operate with the antenna types listed below, with the maximum permissible gain indicated. Antenna types not included in this list that have a gain greater than the maximum gain indicated for any type listed are strictly prohibited for use with this device.

Immediately following the above notice, the manufacturer shall provide a list of all antenna types which can be used with the transmitter, indicating the maximum permissible antenna gain (in dBi) and the required impedance for each antenna type.

Refer to statement below for compliance.

The manufacturer may design the unit so that the user can replace a broken antenna, but the use of a standard antenna jack or electrical connector is prohibited. Further, this requirement does not apply to intentional radiators that must be professionally installed.

Antenna Connected Construction

The antenna used in this product is an integral Antenna, The directional gains of antenna used for transmitting is -6.39 dBi with impedance 50Ω.

5 Test Setup Photos of the EUT



6 Photos of the EUT

External photos



Shenzhen CTA Testing Technology Co., Ltd.

Room 106, Building 1, Yibaolai Industrial Park, Qiaotou Community, Fuhai Street, Bao'an District, Shenzhen, China
Tel:+86-755 2322 5875 E-mail:cta@cta-test.cn Web:http://www.cta-test.cn

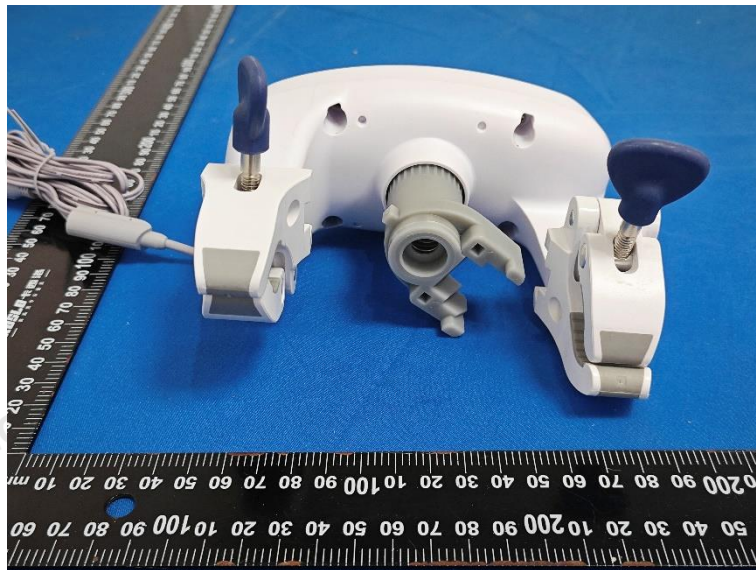

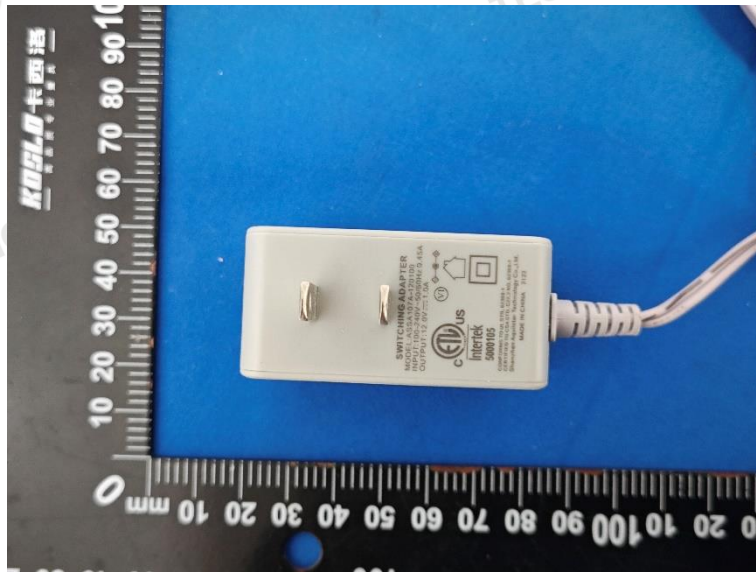

Internal Photos

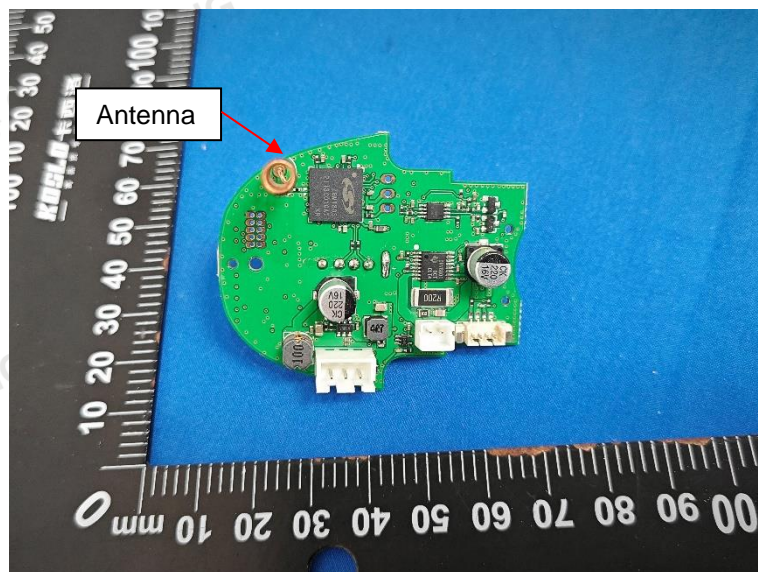
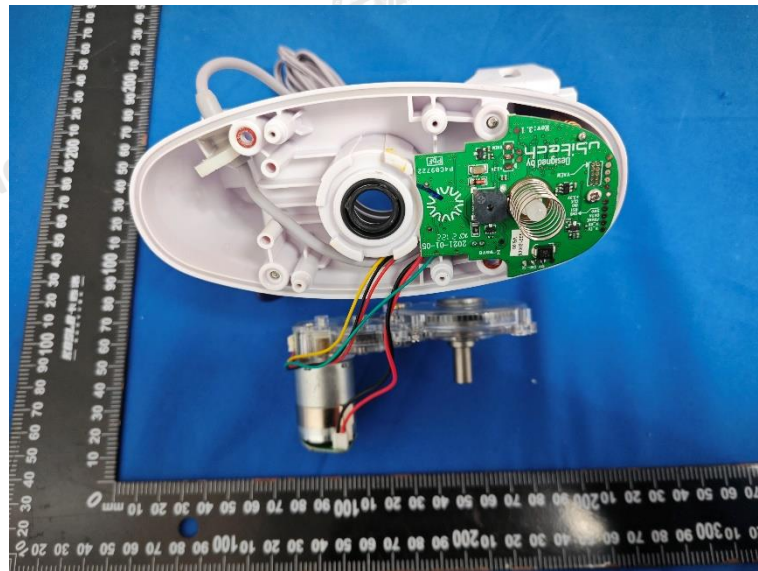

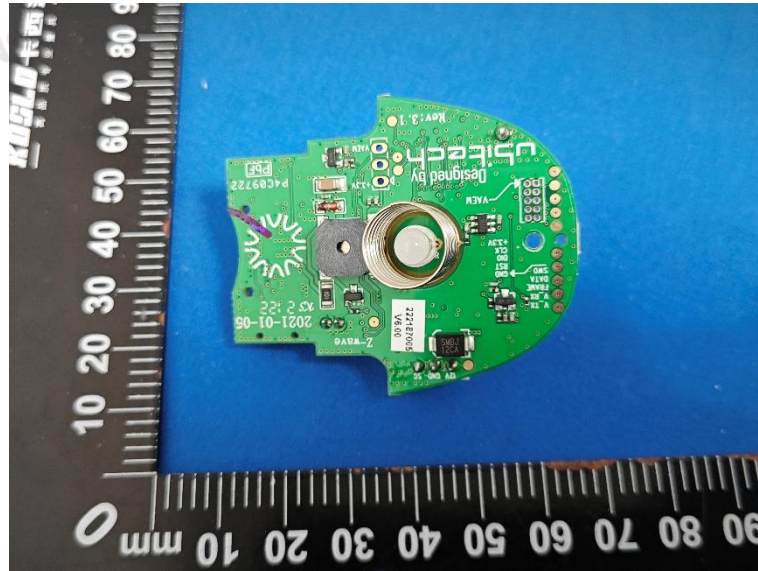

***** End of Report *****