



FCC RF Test Report

APPLICANT : PAX Technology Limited
EQUIPMENT : Multi-Lane Payment Terminal
BRAND NAME : PAX
MODEL NAME : PX7
MARKETING NAME : PX7
FCC ID : V5PPX7BW
STANDARD : FCC Part 15 Subpart C §15.247
CLASSIFICATION : (DTS) Digital Transmission System

The product was received on Apr. 29, 2016 and testing was completed on May 25, 2016. We, SPORTON INTERNATIONAL (SHENZHEN) INC., would like to declare that the tested sample has been evaluated in accordance with the test procedures and has been in compliance with the applicable technical standards.

The test results in this report apply exclusively to the tested model / sample. Without written approval of SPORTON INTERNATIONAL (SHENZHEN) INC., the test report shall not be reproduced except in full.

Prepared by: Ken Chen / Manager

Approved by: Jones Tsai / Manager



SPORTON INTERNATIONAL (SHENZHEN) INC.

**1F & 2F, Building A, Morning Business Center, No. 4003 ShiGu Rd., Xili Town,
Nanshan District, Shenzhen, Guangdong, P. R. China**



TABLE OF CONTENTS

REVISION HISTORY..... 3

SUMMARY OF TEST RESULT 4

1 GENERAL DESCRIPTION 5

 1.1 Applicant 5

 1.2 Manufacturer 5

 1.3 Product Feature of Equipment Under Test..... 5

 1.4 Product Specification of Equipment Under Test..... 5

 1.5 Modification of EUT 6

 1.6 Testing Location 6

 1.7 Applicable Standards..... 6

2 TEST CONFIGURATION OF EQUIPMENT UNDER TEST 7

 2.1 Carrier Frequency Channel 7

 2.2 Pre-Scanned RF Power 8

 2.3 Test Mode..... 9

 2.4 Connection Diagram of Test System..... 10

 2.5 Support Unit used in test configuration and system 11

 2.6 EUT Operation Test Setup 11

 2.7 Measurement Results Explanation Example..... 11

3 TEST RESULT 12

 3.1 6dB and 99% Bandwidth Measurement 12

 3.2 Output Power Measurement..... 14

 3.3 Power Spectral Density Measurement 15

 3.4 Conducted Band Edges and Spurious Emission Measurement 17

 3.5 Radiated Band Edges and Spurious Emission Measurement 27

 3.6 AC Conducted Emission Measurement..... 31

 3.7 Antenna Requirements 35

4 LIST OF MEASURING EQUIPMENT 36

5 UNCERTAINTY OF EVALUATION 37

APPENDIX A. CONDUCTED TEST RESULTS

APPENDIX B. RADIATED TEST RESULTS

APPENDIX C. DUTY CYCLE PLOTS

APPENDIX D. SETUP PHOTOGRAPHS



REVISION HISTORY

REPORT NO.	VERSION	DESCRIPTION	ISSUED DATE
FR642903C	Rev. 01	Initial issue of report	Aug. 19, 2016



SUMMARY OF TEST RESULT

Report Section	FCC Rule	IC Rule	Description	Limit	Result	Remark
3.1	15.247(a)(2)	RSS-247 5.2(1)	6dB Bandwidth	$\geq 0.5\text{MHz}$	Pass	-
3.1	-	RSS-Gen 6.6	99% Bandwidth	-	Pass	-
3.2	15.247(b)	RSS-247 A5.4(4)	Power Output Measurement	$\leq 30\text{dBm}$	Pass	-
3.3	15.247(e)	RSS-247 5.2(2)	Power Spectral Density	$\leq 8\text{dBm}/3\text{kHz}$	Pass	-
3.4	15.247(d)	RSS-247 5.5	Conducted Band Edges	$\leq 20\text{dBc}$	Pass	-
			Conducted Spurious Emission		Pass	-
3.5	15.247(d)	RSS-247 5.5	Radiated Band Edges and Radiated Spurious Emission	15.209(a) & 15.247(d)	Pass	Under limit 1.10 dB at 2483.520 MHz
3.6	15.207	RSS-GEN 8.8	AC Conducted Emission	15.207(a)	Pass	Under limit 10.97 dB at 0.360 MHz
3.7	15.203 & 15.247(b)	N/A	Antenna Requirement	N/A	Pass	-



1 General Description

1.1 Applicant

PAX Technology Limited

Room 2416, 24/F., Sun Hung Kai Centre, 30 Harbour Road, Wanchai, Hong Kong

1.2 Manufacturer

PAX Computer Technology (Shenzhen) Co., Ltd.

4/F, No.3 Building, Software Park, Second Central Science-Tech Road, High-Tech industrial Park, Shenzhen, Guangdong, P.R.C.

1.3 Product Feature of Equipment Under Test

Product Feature	
Equipment	Multi-Lane Payment Terminal
Brand Name	PAX
Model Name	PX7
Marketing Name	PX7
FCC ID	V5PPX7BW
EUT supports Radios application	NFC/WLAN2.4GHz 802.11b/g/n HT20/ Bluetooth v3.0+ EDR/Bluetooth v4.0 LE
HW Version	PX7-xxx-xxx-xxxx
SW Version	14.00.xx
EUT Stage	Identical Prototype

Remark: The above EUT's information was declared by manufacturer. Please refer to the specifications or user's manual for more detailed description.

1.4 Product Specification of Equipment Under Test

Standards-related Product Specification	
Tx/Rx Channel Frequency Range	2412 MHz ~ 2462 MHz
Maximum (Peak) Output Power to Antenna	802.11b : 16.87 dBm (0.0486 W) 802.11g : 22.29 dBm (0.1694 W) 802.11n HT20 : 20.62 dBm (0.1153 W)
99% Occupied Bandwidth	802.11b : 14.14MHz 802.11g : 18.13MHz 802.11n HT20 : 18.88MHz
Antenna Type / Gain	Monopole Antenna with gain 1.20 dBi
Type of Modulation	802.11b : DSSS (DBPSK / DQPSK / CCK) 802.11g/n : OFDM (BPSK / QPSK / 16QAM / 64QAM)



1.5 Modification of EUT

No modifications are made to the EUT during all test items.

1.6 Testing Location

Test Site	SPORTON INTERNATIONAL (SHENZHEN) INC.	
Test Site Location	1F & 2F, Building A, Morning Business Center, No. 4003 ShiGu Rd., Xili Town, Nanshan District, Shenzhen, Guangdong, P. R. China TEL: +86-755-8637-9589 FAX: +86-755-8637-9595	
Test Site No.	Sporton Site No.	
	TH01-SZ	CO01-SZ

Test Site	SPORTON INTERNATIONAL (SHENZHEN) INC.	
Test Site Location	No. 3 Building, the third floor of south, Shahe River west, Fengzeyuan warehouse, Nanshan District, Shenzhen, Guangdong, P. R. China TEL: +86-755- 3320-2398	
Test Site No.	Sporton Site No.	FCC/IC Registration No.
	03CH03-SZ	565805/4086F

Note: The test site complies with ANSI C63.4 2014 requirement.

1.7 Applicable Standards

According to the specifications of the manufacturer, the EUT must comply with the requirements of the following standards:

- ♦ FCC Part 15 Subpart C §15.247
- ♦ FCC KDB Publication No. 558074 D01 DTS Meas. Guidance v03r05
- ♦ ANSI C63.10-2013

Remark:

1. All test items were verified and recorded according to the standards and without any deviation during the test.
2. This EUT has also been tested and complied with the requirements of FCC Part 15, Subpart B, recorded in a separate test report.



2 Test Configuration of Equipment Under Test

The EUT has been associated with peripherals and configuration operated in a manner tended to maximize its emission characteristics in a typical application. Frequency range investigated: conducted emission (150 kHz to 30 MHz) and radiated emission (9 kHz to the 10th harmonic of the highest fundamental frequency or to 40 GHz, whichever is lower). For radiated measurement, pre-scanned in three orthogonal panels, X, Y, Z. The worst cases (Y plane) were recorded in this report.

The final configuration from all the combinations and the worst-case data rates were investigated by measuring the maximum power across all the data rates and modulation modes under section 2.2.

Based on the worst configuration found above, the RF power setting is set individually to meet FCC compliance limit for the final conducted and radiated tests shown in section 2.3.

2.1 Carrier Frequency Channel

Frequency Band	Channel	Freq. (MHz)	Channel	Freq. (MHz)
2400-2483.5 MHz	1	2412	7	2442
	2	2417	8	2447
	3	2422	9	2452
	4	2427	10	2457
	5	2432	11	2462
	6	2437	-	-



2.2 Pre-Scanned RF Power

Preliminary tests were performed in different data rate and data rate associated with the highest power were chosen for full test shown in the following tables.

2.4GHz 802.11b RF Output Power (dBm)						
Power vs. Channel			Power vs. Data Rate			
Channel	Frequency (MHz)	Data Rate	Channel	2Mbps	5.5Mbps	11Mbps
		1Mbps				
CH 01	2412	16.87	CH 01	16.56	16.85	16.76
CH 06	2437	16.74				
CH 11	2462	16.41				

2.4GHz 802.11g RF Output Power (dBm)										
Power vs. Channel			Power vs. Data Rate							
Channel	Frequency (MHz)	Data Rate	Channel	9Mbps	12Mbps	18Mbps	24Mbps	36Mbps	48Mbps	54Mbps
		6Mbps								
CH 01	2412	22.29	CH 01	22.16	22.09	22.01	22.14	22.19	22.20	22.26
CH 06	2437	22.18								
CH 11	2462	21.86								

2.4GHz 802.11n HT20 RF Output Power (dBm)										
Power vs. Channel			Power vs. MCS Index							
Channel	Frequency (MHz)	MCS Index	Channel	MCS1	MCS2	MCS3	MCS4	MCS5	MCS6	MCS7
		MCS0								
CH 01	2412	20.62	CH 01	20.54	20.33	20.48	20.19	20.25	20.43	20.58
CH 06	2437	20.38								
CH 11	2462	20.46								



2.3 Test Mode

Final test mode of conducted test items and radiated spurious emissions are considering the modulation and worse data rates from the power table described in section 2.2.

<2.4GHz>

Modulation	Data Rate
802.11b	1 Mbps
802.11g	6 Mbps
802.11n HT20	MCS0

Test Cases	
AC Conducted Emission	Mode 1 : WLAN Link + Bluetooth Link + LAN Link + Adapter + Touch Pen
Remark: For radiated TCs, the tests were performed with adapter.	

2.4 Connection Diagram of Test System

<WLAN Tx Mode>

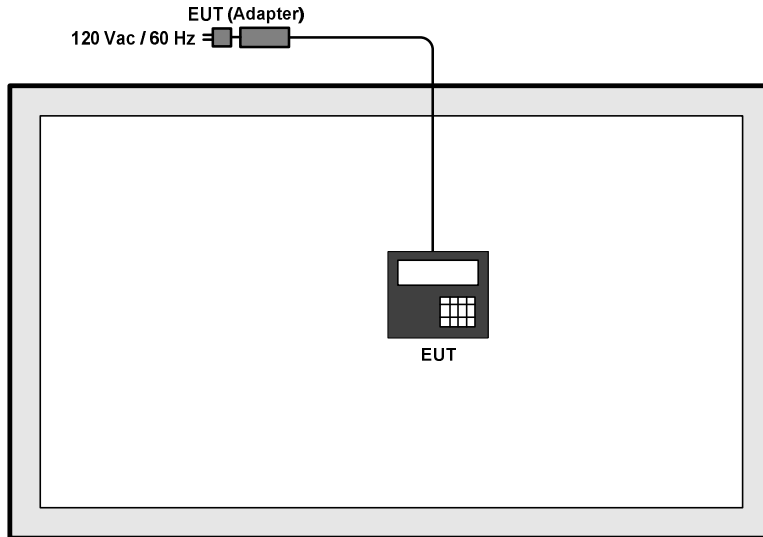

<AC Conducted Emission Mode>

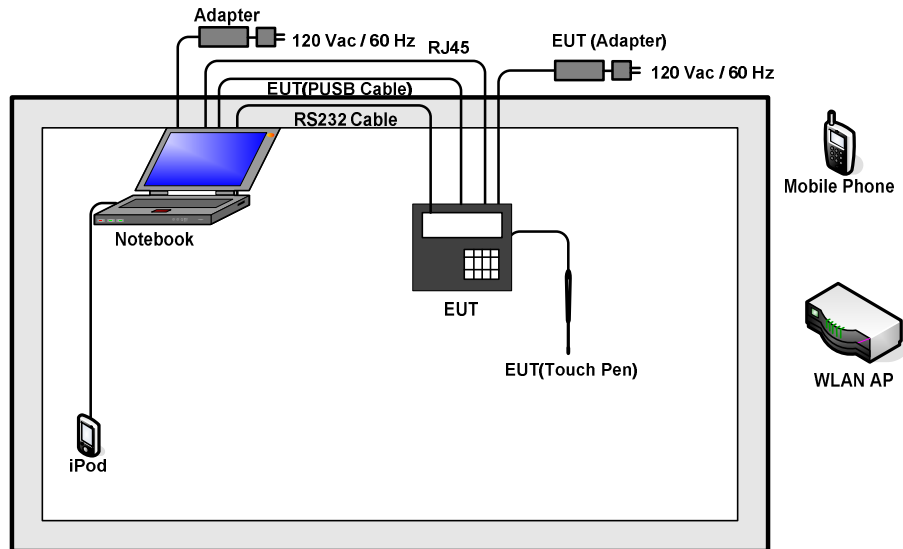



2.5 Support Unit used in test configuration and system

Item	Equipment	Trade Name	Model Name	FCC ID	Data Cable	Power Cord
1.	WLAN AP	ASUS	RT-AC66U	MSQ-RTAC66U	N/A	Unshielded, 1.8 m
2.	Notebook	Lenovo	E540	FCC DoC	N/A	AC I/P: Unshielded, 1.2 m DC O/P: Shielded, 1.8 m
3.	SD Card	SanDisk	4G class 4	FCC DoC	N/A	N/A
4.	iPod	Apple	MC690ZP/A	FCC DoC	Shielded, 1.0 m	N/A
5.	RS232 Cable	N/A	N/A	N/A	N/A	N/A
6.	iPhone	Apple	iPhone5S	FCC DoC	N/A	N/A

2.6 EUT Operation Test Setup

For WLAN function, the engineering test program was provided and enabled to make EUT continuous transmit/receive.

For AC power line conducted emissions, the EUT was set to connect with the WLAN AP under large package sizes transmission.

2.7 Measurement Results Explanation Example

For all conducted test items:

The offset level is set in the spectrum analyzer to compensate the RF cable loss and attenuator factor between EUT conducted output port and spectrum analyzer. With the offset compensation, the spectrum analyzer reading level is exactly the EUT RF output level.

Example :

The spectrum analyzer offset is derived from RF cable loss and attenuator factor.

Offset = RF cable loss + attenuator factor.

Following shows an offset computation example with cable loss 5 dB and 10dB attenuator.

$$\begin{aligned} \text{Offset(dB)} &= \text{RF cable loss(dB)} + \text{attenuator factor(dB)}. \\ &= 5 + 10 = 15 \text{ (dB)} \end{aligned}$$

3 Test Result

3.1 6dB and 99% Bandwidth Measurement

3.1.1 Limit of 6dB and 99% Bandwidth

The minimum 6 dB bandwidth shall be at least 500 kHz.

3.1.2 Measuring Instruments

The measuring equipment is listed in the section 4 of this test report.

3.1.3 Test Procedures

1. The testing follows FCC KDB Publication No. 558074 DTS D01 Meas. Guidance v03r05.
2. The RF output of EUT was connected to the spectrum analyzer by RF cable and attenuator. The path loss was compensated to the results for each measurement.
3. Set to the maximum power setting and enable the EUT transmit continuously.
4. Make the measurement with the spectrum analyzer's resolution bandwidth (RBW) = 100 kHz. Set the Video bandwidth (VBW) = 300 kHz. In order to make an accurate measurement. The 6 dB bandwidth must be greater than 500 kHz.
5. For 99% Bandwidth Measurement, the spectrum analyzer's resolution bandwidth (RBW) = 1MHz and set the Video bandwidth (VBW) = 3MHz.
6. Measure and record the results in the test report.

3.1.4 Test Setup

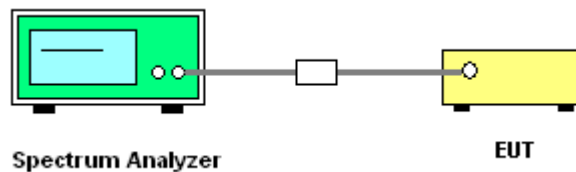



3.1.5 Test Result of 6dB and 99% Occupied Bandwidth

Please refer to Appendix A of this test report.

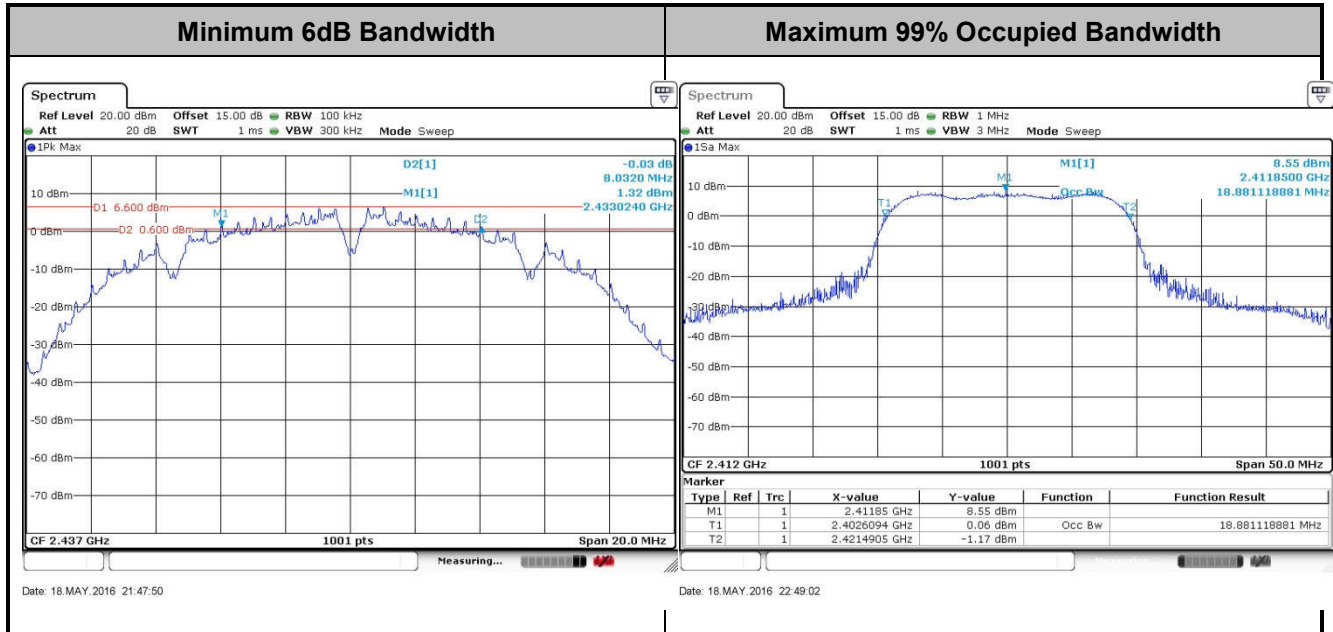

Note: The occupied channel bandwidth is maintained within the band of operation for all of the modulations.

3.2 Output Power Measurement

3.2.1 Limit of Output Power

For systems using digital modulation in the 2400-2483.5MHz, the limit for peak output power is 30dBm. If transmitting Antenna of directional gain greater than 6dBi are used the peak output power from the intentional radiator shall be reduced below the above stated value by the amount in dB that the directional gain of the Antenna exceeds 6 dBi. In case of point-to-point operation, the limit has to be reduced by 1dB for every 3dB that the directional gain of the Antenna exceeds 6dBi.

3.2.2 Measuring Instruments

The measuring equipment is listed in the section 4 of this test report.

3.2.3 Test Procedures

1. The testing follows the Measurement Procedure of FCC KDB No. 558074 DTS D01 Meas. Guidance v03r05 section 9.1.2 PKPM1 Peak power meter method.
2. The RF output of EUT was connected to the power meter by RF cable and attenuator. The path loss was compensated to the results for each measurement.
3. Set to the maximum power setting and enable the EUT transmit continuously.
4. Measure the conducted output power and record the results in the test report.

3.2.4 Test Setup

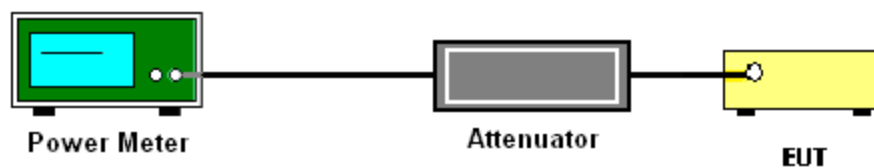

3.2.5 Test Result of Peak Output Power

Please refer to Appendix A of this test report.

3.2.6 Test Result of Average output Power (Reporting Only)

Please refer to Appendix A of this test report.

3.3 Power Spectral Density Measurement

3.3.1 Limit of Power Spectral Density

The peak power spectral density shall not be greater than 8dBm in any 3kHz band at any time interval of continuous transmission.

3.3.2 Measuring Instruments

The measuring equipment is listed in the section 4 of this test report.

3.3.3 Test Procedures

1. The testing follows Measurement Procedure 10.2 Method PKPSD of FCC KDB Publication No. 558074 D01 DTS Meas. Guidance v03r05
2. The RF output of EUT was connected to the spectrum analyzer by RF cable and attenuator. The path loss was compensated to the results for each measurement.
3. Set to the maximum power setting and enable the EUT transmit continuously.
4. Make the measurement with the spectrum analyzer's resolution bandwidth (RBW) = 3 kHz. Video bandwidth VBW = 10 kHz In order to make an accurate measurement, set the span to 1.5 times DTS Channel Bandwidth. (6dB BW)
5. Detector = peak, Sweep time = auto couple, Trace mode = max hold, Allow trace to fully stabilize. Use the peak marker function to determine the maximum power level.
6. Measure and record the results in the test report.

3.3.4 Test Setup

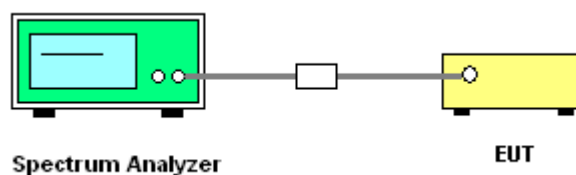



3.3.5 Test Result of Power Spectral Density

Please refer to Appendix A of this test report.

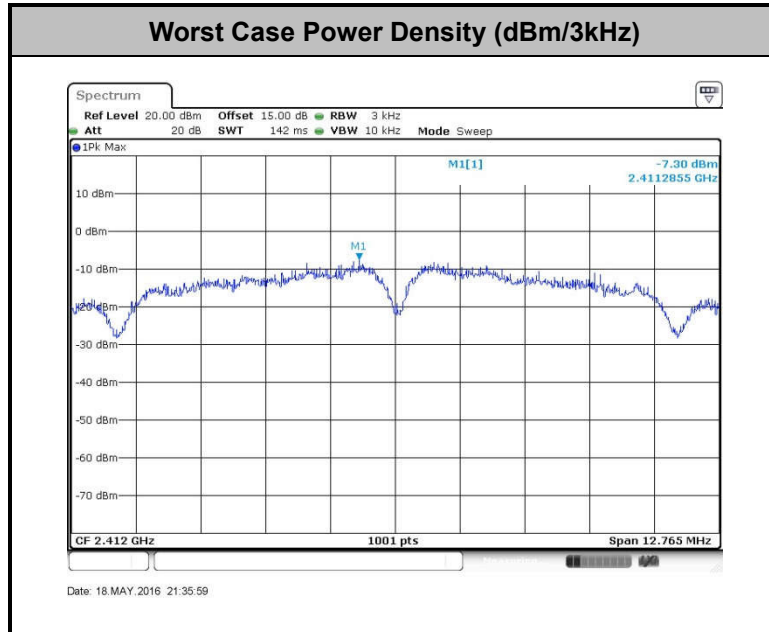

3.4 Conducted Band Edges and Spurious Emission Measurement

3.4.1 Limit of Conducted Band Edges and Spurious Emission Measurement

In any 100 kHz bandwidth outside of the authorized frequency band, the emissions which fall in the non-restricted bands shall be attenuated at least 20 dB / 30dB relative to the maximum PSD level in 100 kHz by RF conducted measurement and radiated emissions which fall in the restricted bands, as defined in Section 15.205(a), must also comply with the radiated emission limits specified in Section 15.209(a).

3.4.2 Measuring Instruments

The measuring equipment is listed in the section 4 of this test report.

3.4.3 Test Procedures

1. The testing follows FCC KDB Publication No. 558074 D01 DTS Meas. Guidance v03r05.
2. The RF output of EUT was connected to the spectrum analyzer by RF cable and attenuator. The path loss was compensated to the results for each measurement.
3. Set to the maximum power setting and enable the EUT transmit continuously.
4. Set RBW = 100 kHz, VBW=300 kHz, Peak Detector. Unwanted Emissions measured in any 100 kHz bandwidth outside of the authorized frequency band shall be attenuated by at least 20 dB relative to the maximum in-band peak PSD level in 100 kHz when maximum peak conducted output power procedure is used. If the transmitter complies with the conducted power limits based on the use of RMS averaging over a time interval, the attenuation required under this paragraph shall be 30 dB instead of 20 dB per 15.247(d).
5. Measure and record the results in the test report.
6. The RF fundamental frequency should be excluded against the limit line in the operating frequency band.

3.4.4 Test Setup

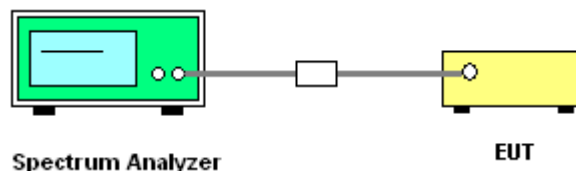



3.4.5 Test Result of Conducted Band Edges and Spurious Emission

Test Mode :	802.11b	Temperature :	24~26°C
Test Band :	2.4GHz Low	Relative Humidity :	50~53%
Test Channel :	01	Test Engineer :	Ting You

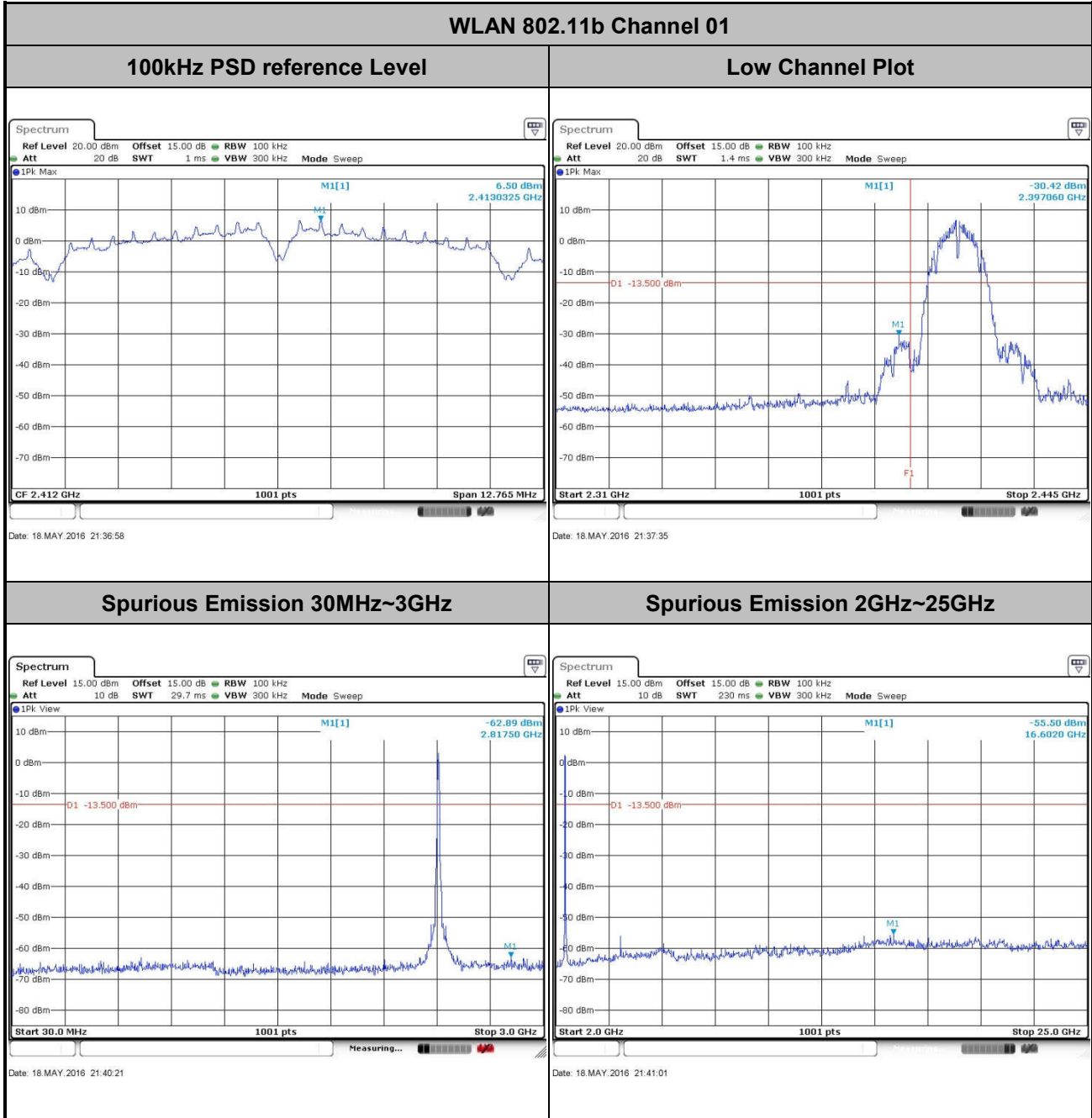



Test Mode :	802.11b	Temperature :	24~26°C
Test Band :	2.4GHz Mid	Relative Humidity :	50~53%
Test Channel :	06	Test Engineer :	Ting You

WLAN 802.11b Channel 06

100kHz PSD reference Level

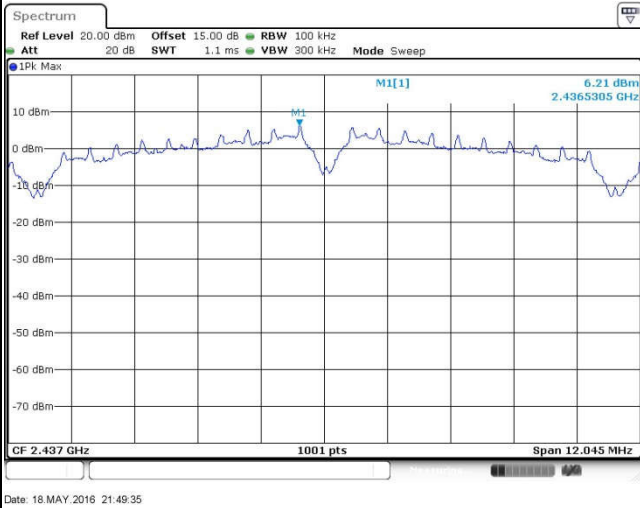

Spurious Emission 30MHz~3GHz

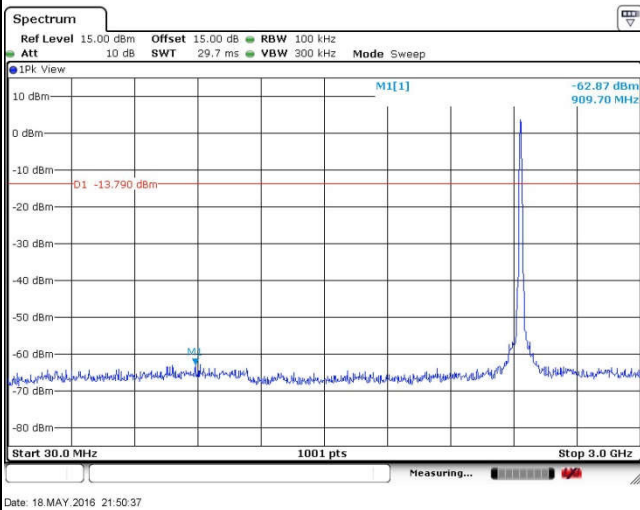

Spurious Emission 2GHz~25GHz

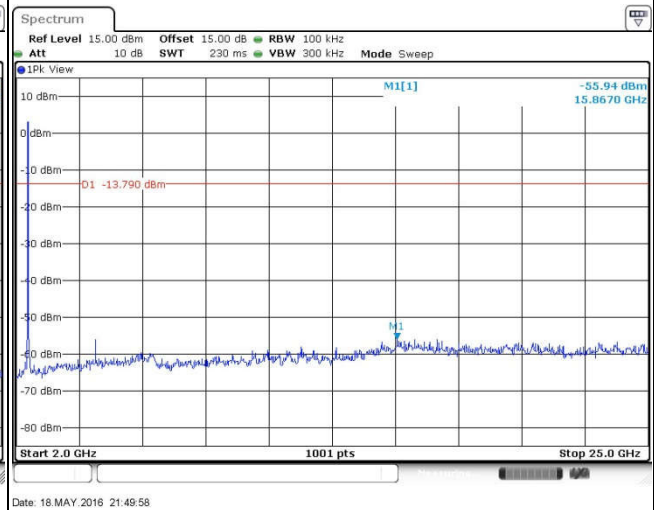



Test Mode :	802.11b	Temperature :	24~26°C
Test Band :	2.4GHz High	Relative Humidity :	50~53%
Test Channel :	11	Test Engineer :	Ting You

WLAN 802.11b Channel 11

100kHz PSD reference Level

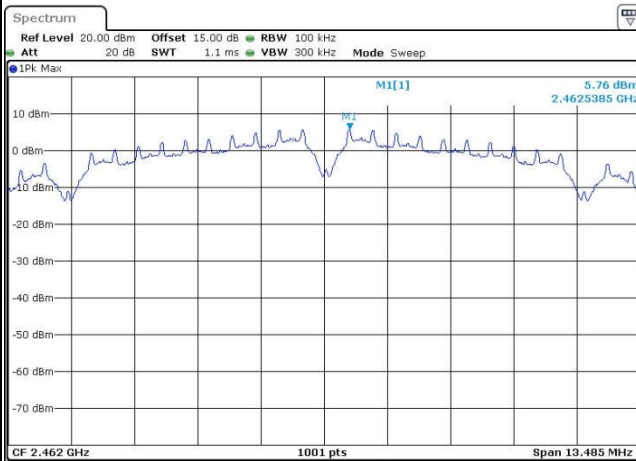

Date: 18.MAY.2016 21:58:23

High Channel Plot

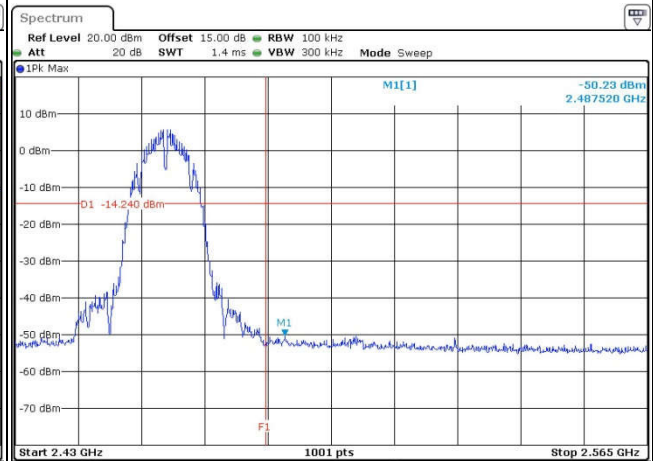

Date: 18.MAY.2016 21:58:58

Spurious Emission 30MHz~3GHz

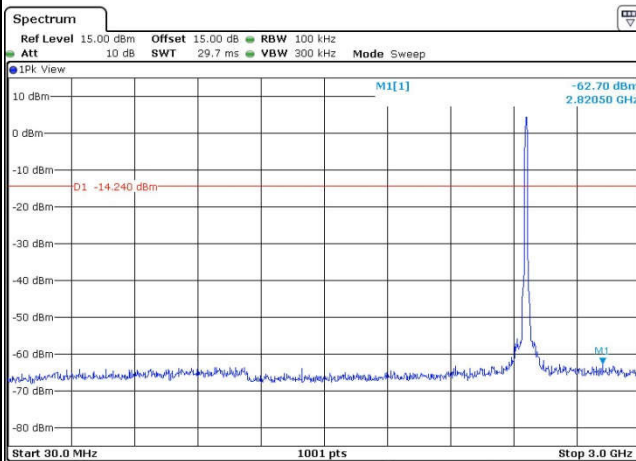

Date: 18.MAY.2016 22:01:34

Spurious Emission 2GHz~25GHz

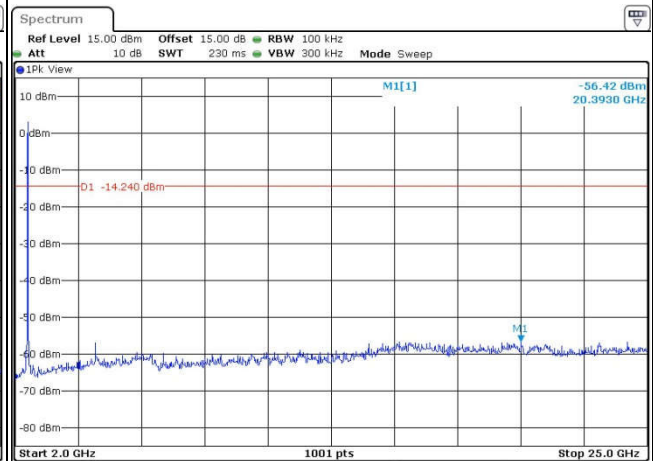

Date: 18.MAY.2016 21:59:22



Test Mode :	802.11g	Temperature :	24~26°C
Test Band :	2.4GHz Low	Relative Humidity :	50~53%
Test Channel :	01	Test Engineer :	Ting You

WLAN 802.11g Channel 01

100kHz PSD reference Level

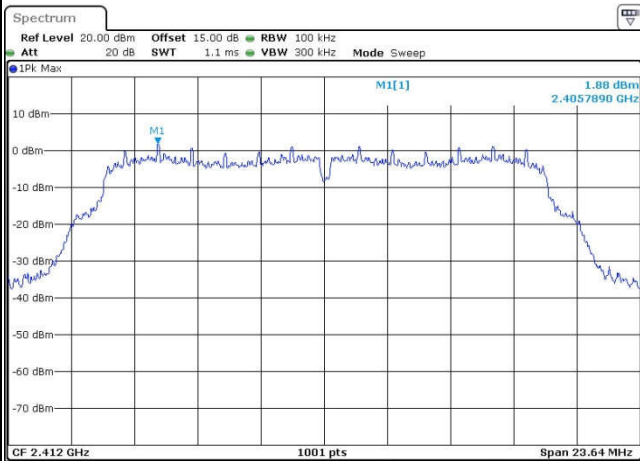

Date: 18.MAY.2016 22:14:05

Low Channel Plot

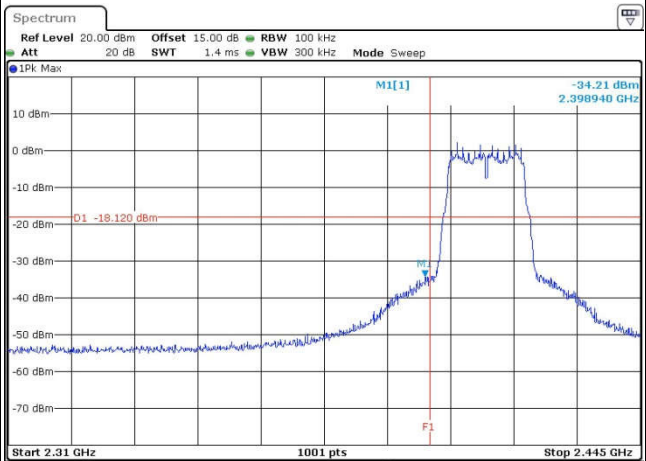

Date: 18.MAY.2016 22:14:52

Spurious Emission 30MHz~3GHz

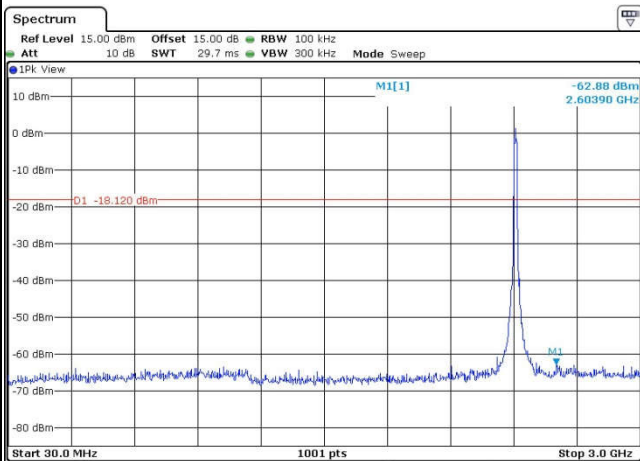

Date: 18.MAY.2016 22:16:09

Spurious Emission 2GHz~25GHz

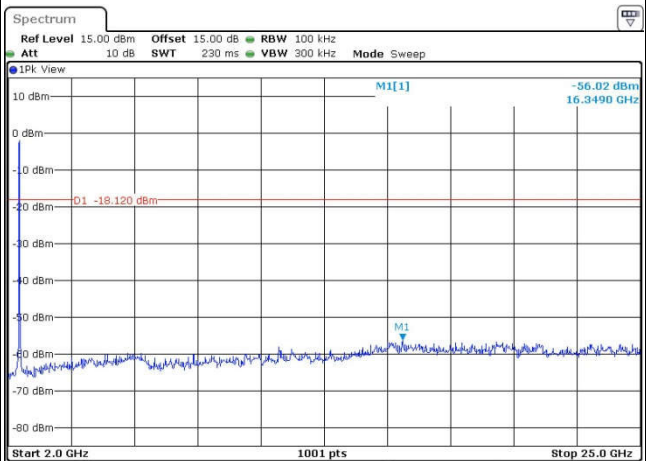

Date: 18.MAY.2016 22:15:32



Test Mode :	802.11g	Temperature :	24~26°C
Test Band :	2.4GHz Mid	Relative Humidity :	50~53%
Test Channel :	06	Test Engineer :	Ting You

WLAN 802.11g Channel 06

100kHz PSD reference Level

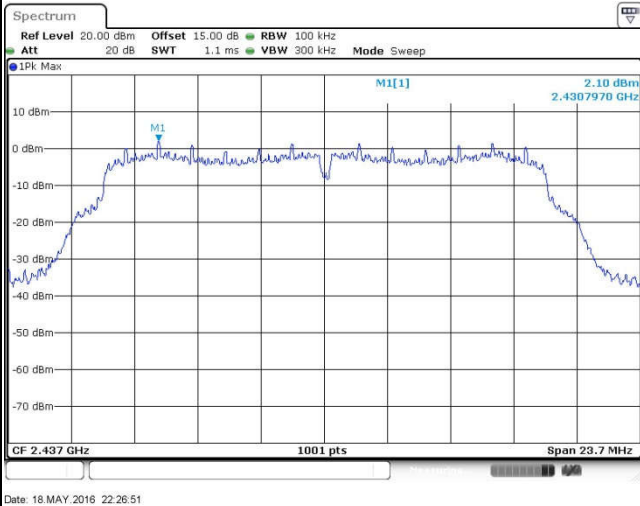

Spurious Emission 30MHz~3GHz

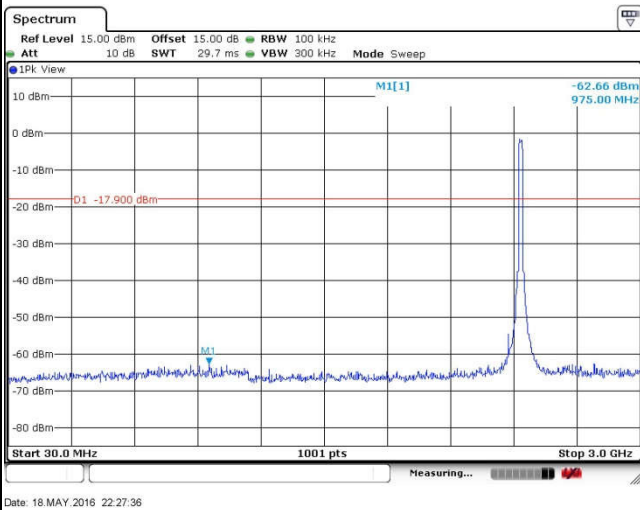

Spurious Emission 2GHz~25GHz

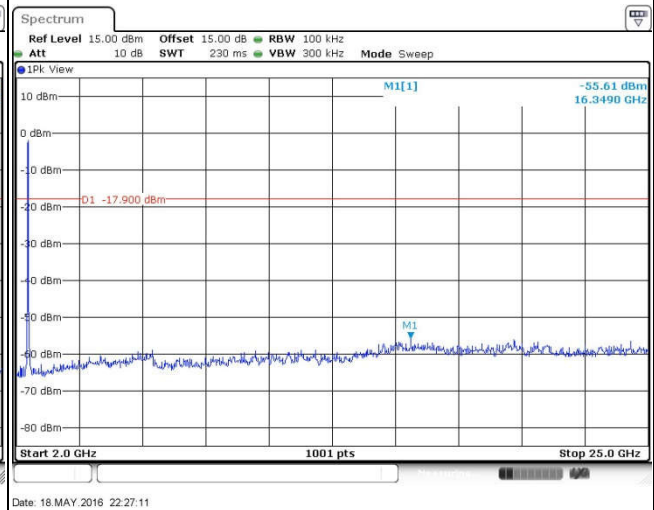



Test Mode :	802.11g	Temperature :	24~26°C
Test Band :	2.4GHz High	Relative Humidity :	50~53%
Test Channel :	11	Test Engineer :	Ting You

WLAN 802.11g Channel 11

100kHz PSD reference Level

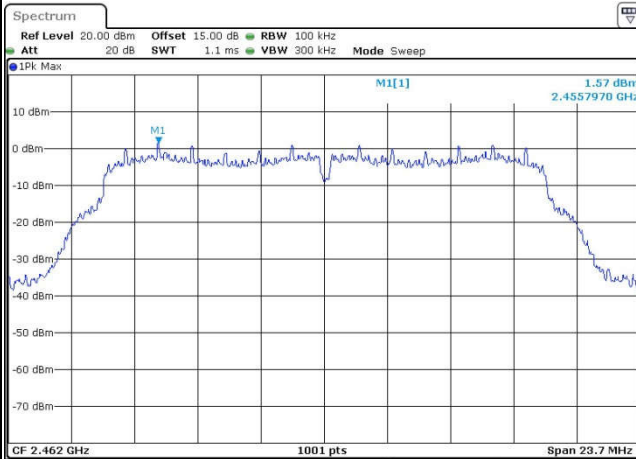

Date: 18.MAY.2016 22:34:42

High Channel Plot

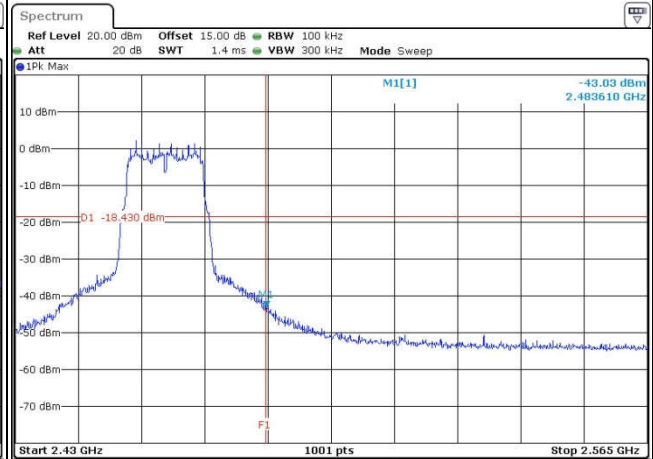

Date: 18.MAY.2016 22:35:36

Spurious Emission 30MHz~3GHz

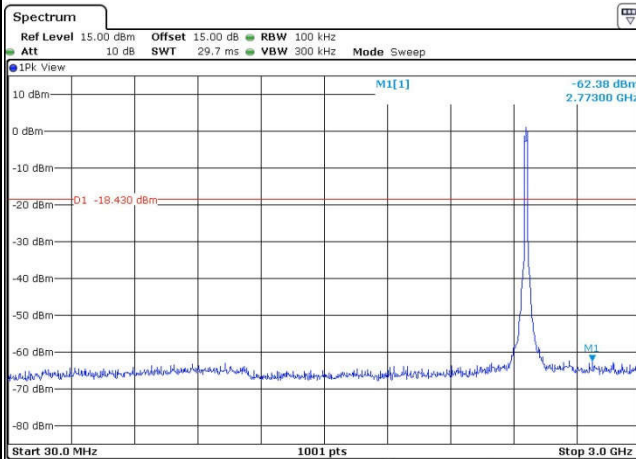

Date: 18.MAY.2016 22:36:26

Spurious Emission 2GHz~25GHz

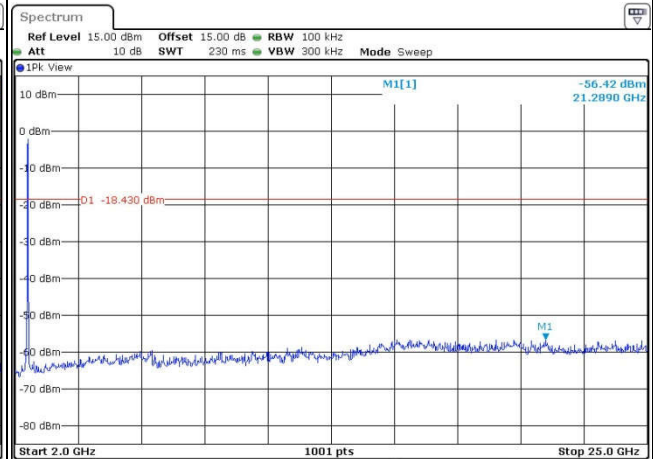

Date: 18.MAY.2016 22:35:58



Test Mode :	802.11n HT20	Temperature :	24~26°C
Test Band :	2.4GHz Low	Relative Humidity :	50~53%
Test Channel :	01	Test Engineer :	Ting You

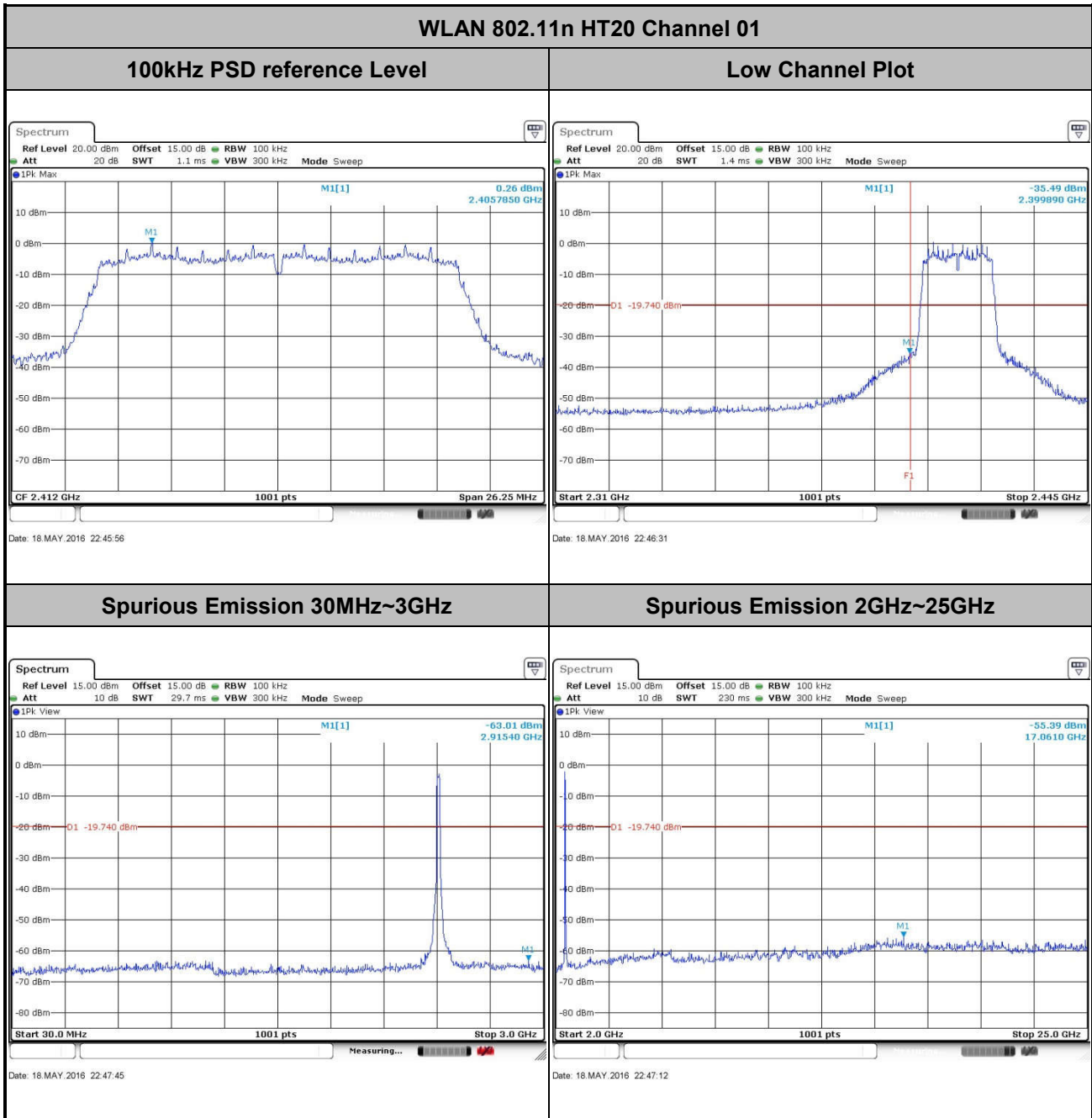



Test Mode :	802.11n HT20	Temperature :	24~26°C
Test Band :	2.4GHz Mid	Relative Humidity :	50~53%
Test Channel :	06	Test Engineer :	Ting You

WLAN 802.11n HT20 Channel 06

100kHz PSD reference Level

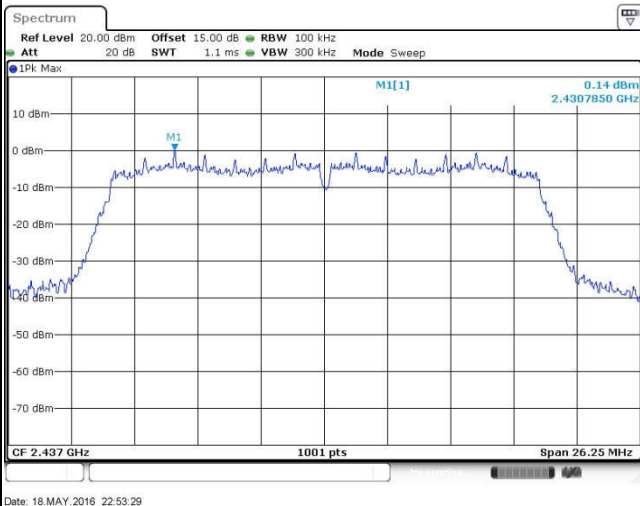

Spurious Emission 30MHz~3GHz

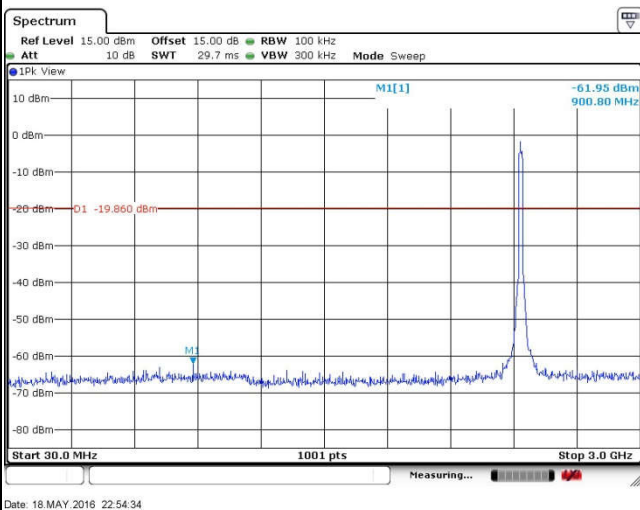

Spurious Emission 2GHz~25GHz

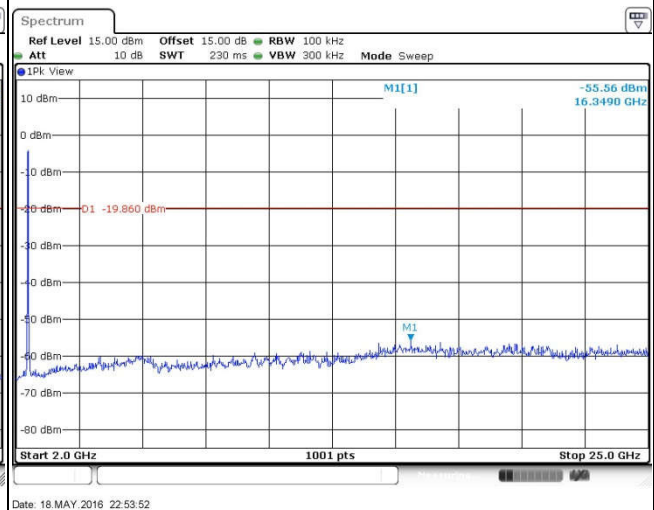



Test Mode :	802.11n HT20	Temperature :	24~26°C
Test Band :	2.4GHz High	Relative Humidity :	50~53%
Test Channel :	11	Test Engineer :	Ting You

WLAN 802.11n HT20 Channel 11

100kHz PSD reference Level

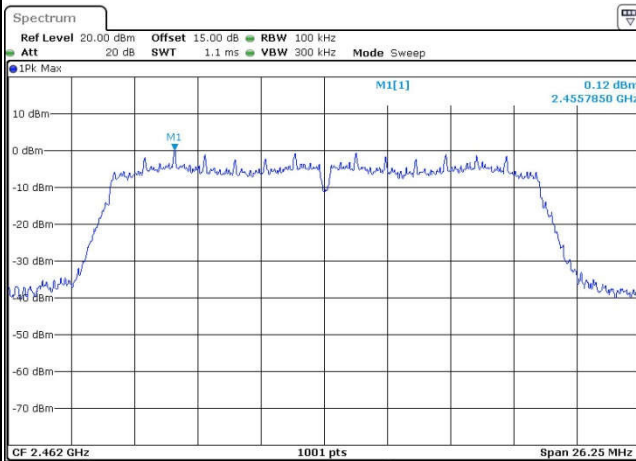

Date: 18.MAY.2016 23:02:53

High Channel Plot

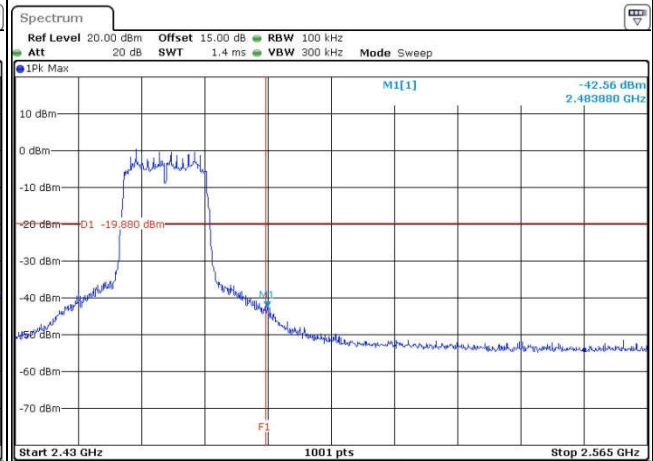

Date: 18.MAY.2016 23:03:51

Spurious Emission 30MHz~3GHz

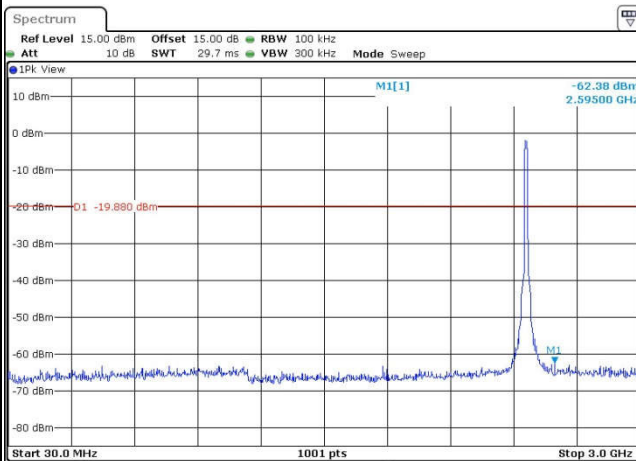

Date: 18.MAY.2016 23:04:04

Spurious Emission 2GHz~25GHz

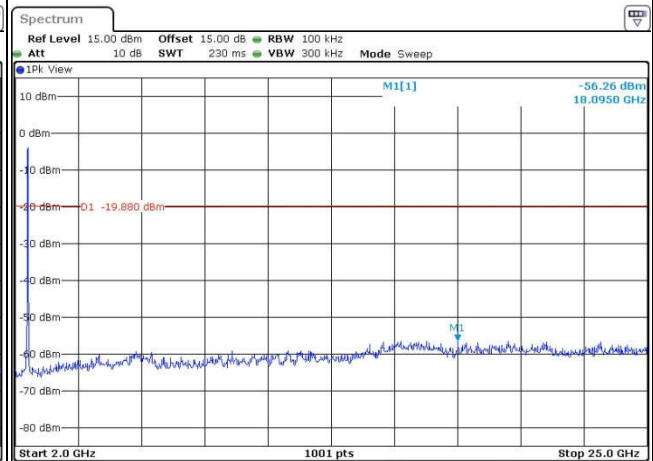

Date: 18.MAY.2016 23:04:13



3.5 Radiated Band Edges and Spurious Emission Measurement

3.5.1 Limit of Radiated band edge and Spurious Emission Measurement

In any 100 kHz bandwidth outside the intentional radiator frequency band, all harmonics/spurious must be at least 20 dB below the highest emission level within the authorized band. If the output power of this device was measured by spectrum analyzer, the attenuation under this paragraph shall be 30 dB instead of 20 dB. In addition, radiated emissions which fall in the restricted bands must also comply with the FCC section 15.209 limits as below.

Frequency (MHz)	Field Strength (microvolts/meter)	Measurement Distance (meters)
0.009 – 0.490	2400/F(kHz)	300
0.490 – 1.705	24000/F(kHz)	30
1.705 – 30.0	30	30
30 – 88	100	3
88 – 216	150	3
216 - 960	200	3
Above 960	500	3

3.5.2 Measuring Instruments

The measuring equipment is listed in the section 4 of this test report.



3.5.3 Test Procedures

1. The testing follows FCC KDB Publication No. 558074 D01 DTS Meas. Guidance v03r05.
2. The EUT was arranged to its worst case and then tune the antenna tower (from 1 m to 4 m) and turntable (from 0 degree to 360 degrees) to find the maximum reading. A pre-amp and a high pass filter are used for the test in order to get better signal level.
3. The EUT was placed on a turntable with 0.8 meter for frequency below 1GHz and 1.5 meter for frequency above 1GHz respectively above ground.
4. The EUT was set 3 meters from the interference receiving antenna, which was mounted on the top of a variable height antenna tower.
5. Corrected Reading: Antenna Factor + Cable Loss + Read Level - Preamp Factor = Level
6. For measurement below 1GHz, If the emission level of the EUT measured by the peak detector is 3 dB lower than the applicable limit, the peak emission level will be reported. Otherwise, the emission measurement will be repeated using the quasi-peak detector and reported.
7. Use the following spectrum analyzer settings:
 - (1) Span shall wide enough to fully capture the emission being measured;
 - (2) Set RBW=100 kHz for $f < 1$ GHz; VBW \geq RBW; Sweep = auto; Detector function = peak; Trace = max hold;
 - (3) Set RBW = 1 MHz, VBW= 3MHz for $f \geq 1$ GHz for peak measurement.
For average measurement:
 - VBW = 10 Hz, when duty cycle is no less than 98 percent.
 - VBW $\geq 1/T$, when duty cycle is less than 98 percent where T is the minimum transmission duration over which the transmitter is on and is transmitting at its maximum power control level for the tested mode of operation.

3.5.4 Test Setup

For radiated emissions below 30MHz

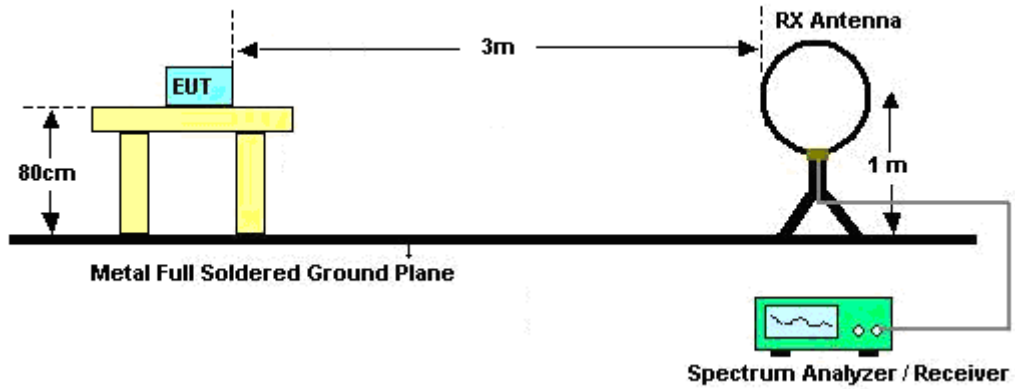

For radiated emissions from 30MHz to 1GHz

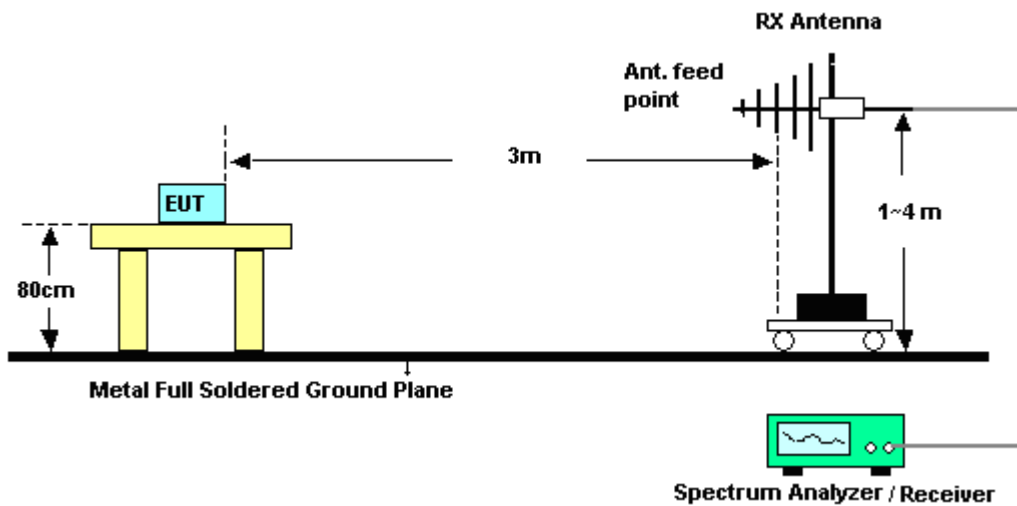

For radiated emissions above 1GHz

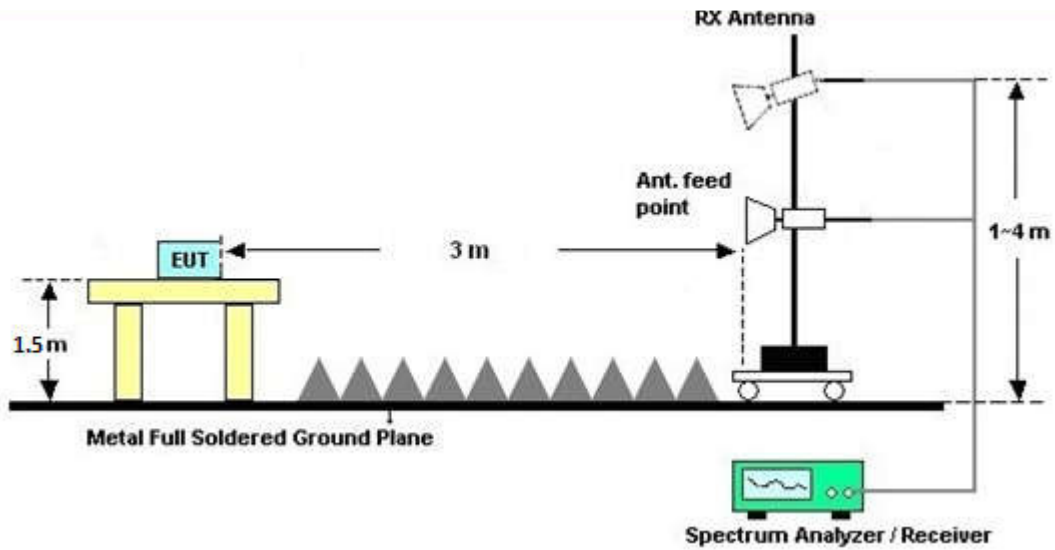

3.5.5 Test Results of Radiated Spurious Emissions (9kHz ~ 30MHz)

The low frequency, which started from 9 kHz to 30MHz, was pre-scanned and the result which was 20dB lower than the limit line per 15.31(o) was not reported.

3.5.6 Test Result of Radiated Spurious at Band Edges

Please refer to Appendix B.

3.5.7 Duty Cycle

Please refer to Appendix C.

3.5.8 Test Result of Radiated Spurious Emission (30MHz ~ 10th Harmonic)

Please refer to Appendix B.



3.6 AC Conducted Emission Measurement

3.6.1 Limit of AC Conducted Emission

For equipment that is designed to be connected to the public utility (AC) power line, the radio frequency voltage that is conducted back onto the AC power line on any frequency or frequencies within the band 150 kHz to 30 MHz shall not exceed the limits in the following table.

Frequency of Emission (MHz)	Conducted Limit (dB μ V)	
	Quasi-Peak	Average
0.15-0.5	66 to 56*	56 to 46*
0.5-5	56	46
5-30	60	50

*Decreases with the logarithm of the frequency.

3.6.2 Measuring Instruments

The measuring equipment is listed in the section 4 of this test report.

3.6.3 Test Procedures

1. The EUT was placed 0.4 meter from the conducting wall of the shielding room, and it was kept at least 80 centimeters from any other grounded conducting surface.
2. Connect EUT to the power mains through a line impedance stabilization network (LISN).
3. All the support units are connecting to the other LISN.
4. The LISN provides 50 ohm coupling impedance for the measuring instrument.
5. The FCC states that a 50 ohm, 50 microhenry LISN should be used.
6. Both sides of AC line were checked for maximum conducted interference.
7. The frequency range from 150 kHz to 30 MHz was searched.
8. Set the test-receiver system to Peak Detect Function and specified bandwidth (IF bandwidth = 9kHz) with Maximum Hold Mode.

3.6.4 Test Setup

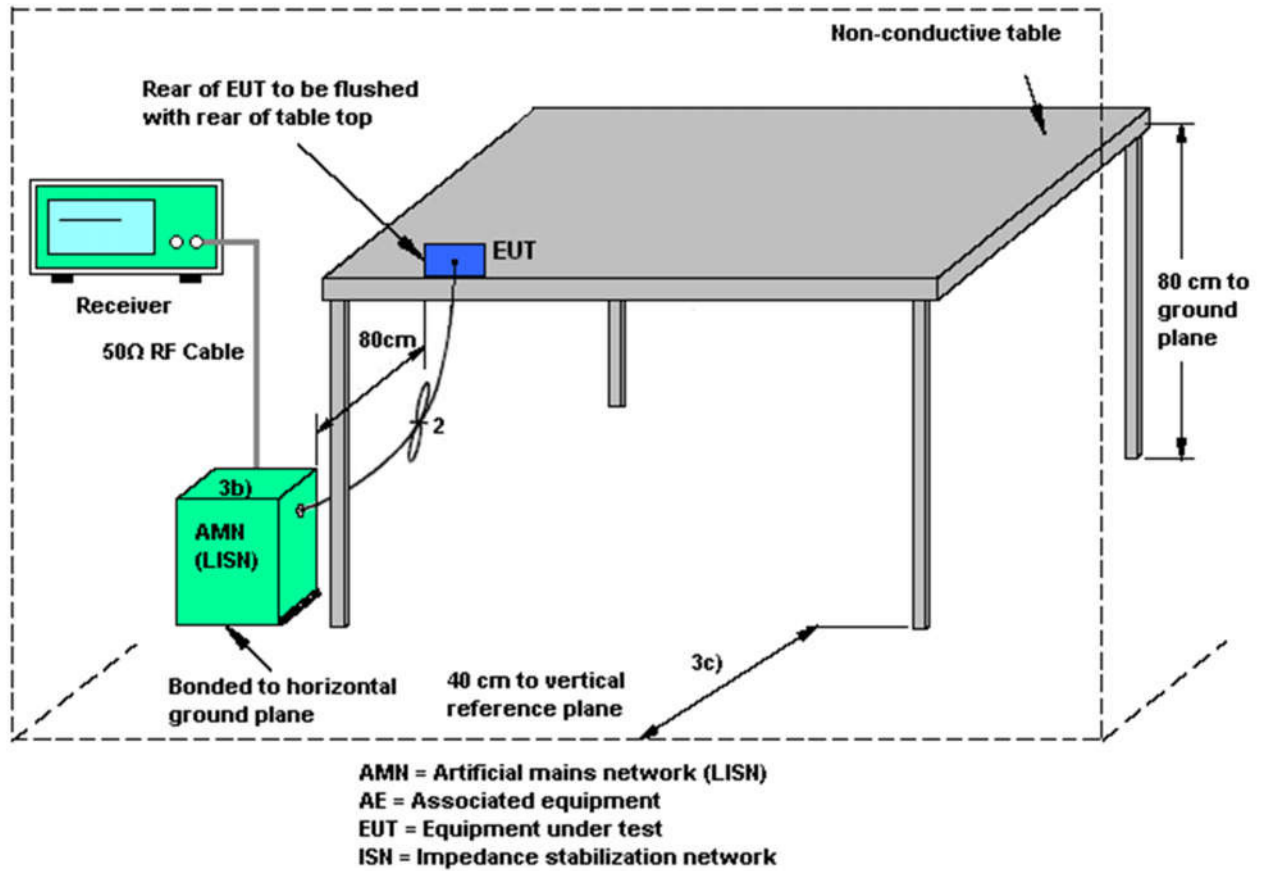



3.6.5 Test Result of AC Conducted Emission

Test Mode :	Mode 1	Temperature :	21~23°C
Test Engineer :	Tao Cheng	Relative Humidity :	41~43%
Test Voltage :	120Vac / 60Hz	Phase :	Line
Function Type :	WLAN Link + Bluetooth Link + LAN Link + Adapter + Touch Pen		

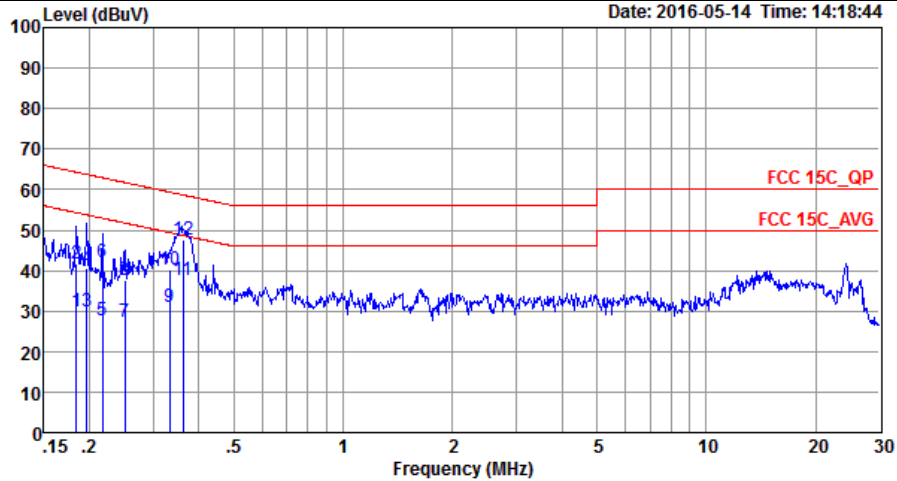

Site : C001-SZ
 Condition: FCC 15C_QP LISN_20160509 LINE

	Freq	Level	Over Limit	Limit Line	Read Level	LISN Factor	Cable Loss	Remark
	MHz	dBuV	dB	dBuV	dBuV	dB	dB	
1	0.18	29.85	-24.43	54.28	19.20	0.12	10.53	Average
2	0.18	41.85	-22.43	64.28	31.20	0.12	10.53	QP
3	0.20	29.72	-24.04	53.76	19.10	0.11	10.51	Average
4	0.20	40.72	-23.04	63.76	30.10	0.11	10.51	QP
5	0.22	27.69	-25.23	52.92	17.10	0.11	10.48	Average
6	0.22	42.09	-20.83	62.92	31.50	0.11	10.48	QP
7	0.25	27.27	-24.46	51.73	16.70	0.11	10.46	Average
8	0.25	37.67	-24.06	61.73	27.10	0.11	10.46	QP
9	0.33	30.97	-18.43	49.40	20.50	0.11	10.36	Average
10	0.33	40.17	-19.23	59.40	29.70	0.11	10.36	QP
11 *	0.36	37.72	-10.97	48.69	27.30	0.11	10.31	Average
12	0.36	47.72	-10.97	58.69	37.30	0.11	10.31	QP



Test Mode :	Mode 1	Temperature :	21~23°C
Test Engineer :	Tao Cheng	Relative Humidity :	41~43%
Test Voltage :	120Vac / 60Hz	Phase :	Neutral
Function Type :	WLAN Link + Bluetooth Link + LAN Link + Adapter + Touch Pen		

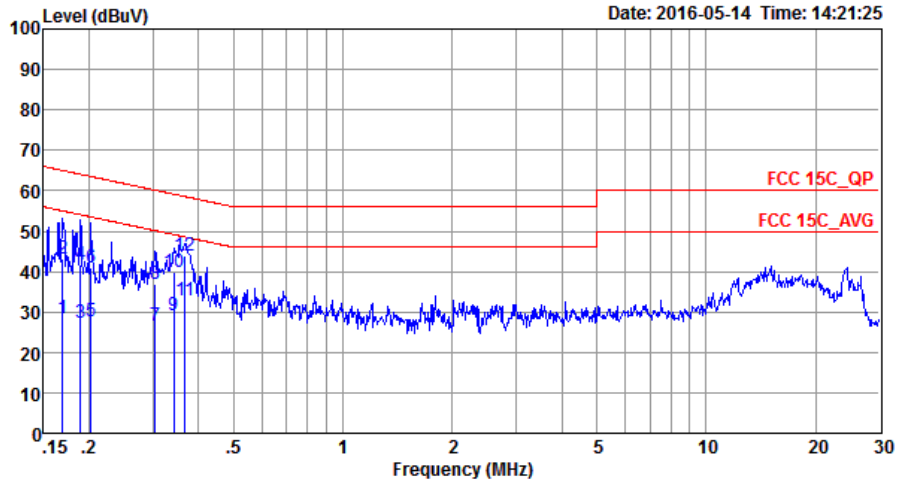

Site : CO01-SZ
 Condition: FCC 15C_QP LISN_20160509 NEUTRAL

	Freq	Level	Over Limit	Limit Line	Read Level	LISN Factor	Cable Loss	Remark
	MHz	dBuV	dB	dBuV	dBuV	dB	dB	
1	0.17	28.38	-26.61	54.99	17.69	0.13	10.56	Average
2	0.17	43.28	-21.71	64.99	32.59	0.13	10.56	QP
3	0.19	27.33	-26.73	54.06	16.69	0.12	10.52	Average
4	0.19	41.73	-22.33	64.06	31.09	0.12	10.52	QP
5	0.20	27.81	-25.68	53.49	17.20	0.11	10.50	Average
6	0.20	40.81	-22.68	63.49	30.20	0.11	10.50	QP
7	0.30	26.52	-23.63	50.15	16.00	0.11	10.41	Average
8	0.30	36.82	-23.33	60.15	26.30	0.11	10.41	QP
9	0.34	29.05	-20.08	49.13	18.60	0.11	10.34	Average
10	0.34	39.75	-19.38	59.13	29.30	0.11	10.34	QP
11	0.37	32.91	-15.65	48.56	22.50	0.11	10.30	Average
12 *	0.37	44.01	-14.55	58.56	33.60	0.11	10.30	QP



3.7 Antenna Requirements

3.7.1 Standard Applicable

If directional gain of transmitting antennas is greater than 6dBi, the power shall be reduced by the same level in dB comparing to gain minus 6dBi. For the fixed point-to-point operation, the power shall be reduced by one dB for every 3 dB that the directional gain of the antenna exceeds 6 dBi. The use of a permanently attached antenna or of an antenna that uses a unique coupling to the intentional radiator shall be considered sufficient to comply with the FCC rule.

3.7.2 Antenna Anti-Replacement Construction

An embedded-in antenna design is used.

3.7.3 Antenna Gain

The antenna peak gain of EUT is less than 6 dBi. Therefore, it is not necessary to reduce maximum peak output power limit.



4 List of Measuring Equipment

Instrument	Manufacturer	Model No.	Serial No.	Characteristics	Calibration Date	Test Date	Due Date	Remark
Spectrum Analyzer	R&S	FSV40	101078	9kHz~40GHz	May 07, 2016	May 17, 2016~ May 18, 2016	May 06, 2017	Conducted (TH01-SZ)
Spectrum Analyzer	R&S	FSP30	101400	9kHz~40GHz	Jan. 12, 2016	May 17, 2016~ May 19, 2016	Jan. 11, 2017	Conducted (TH01-SZ)
Pulse Power Sensor	Anritsu	MA2411B	1207253	30MHz~40GHz	Jan. 12, 2016	May 17, 2016~ May 18, 2016	Jan. 11, 2017	Conducted (TH01-SZ)
Power Meter	Anritsu	ML2495A	1218010	50MHz Bandwidth	Jan. 12, 2016	May 17, 2016~ May 18, 2016	Jan. 11, 2017	Conducted (TH01-SZ)
EMI Test Receiver&SA	KEYSIGHT	N9038A	MY544500 83	20Hz~8.4GHz	May 07, 2016	May 17, 2016~ May 25, 2016	May 06, 2017	Radiation (03CH03-SZ)
EXA Spectrum Analyzer	KEYSIGHT	N9010A	MY551502 46	10Hz~44GHz;	May 07, 2016	May 17, 2016~ May 25, 2016	May 06, 2017	Radiation (03CH03-SZ)
Loop Antenna	R&S	HFH2-Z2	100354	9kHz~30MHz	May 07, 2016	May 17, 2016~ May 25, 2016	May 06, 2017	Radiation (03CH03-SZ)
Bilog Antenna	TeseQ	CBL6112D	23188	30MHz~2GHz	Mar. 12, 2016	May 17, 2016~ May 25, 2016	Mar. 11, 2017	Radiation (03CH03-SZ)
Double Ridge Horn Antenna	SCHWARZBECK	BBHA9120D	9120D-135 5	1GHz~18GHz	May 07, 2016	May 17, 2016~ May 25, 2016	May 06, 2017	Radiation (03CH03-SZ)
SHF-EHF Horn	com-power	AH-840	101071	18GHz~40GHz	Aug. 19, 2015	May 17, 2016~ May 25, 2016	Aug. 18, 2016	Radiation (03CH03-SZ)
Amplifier	PREAMPLIFIER	BPA-530	102210	0.01Hz ~3000MHz	Oct. 20, 2015	May 17, 2016~ May 25, 2016	Oct. 19, 2016	Radiation (03CH03-SZ)
Amplifier	Agilent Technologies	83017A	MY395013 02	500MHz~26.5G Hz	Jan. 12, 2016	May 17, 2016~ May 25, 2016	Jan. 11, 2017	Radiation (03CH03-SZ)
HF Amplifier	MITEQ	TTA1840- 35-HG	1871923	18GHz~40GHz	Jul. 18, 2015	May 17, 2016~ May 25, 2016	Jul. 17, 2016	Radiation (03CH03-SZ)
AC Power Source	Chroma	61601	616010001 985	N/A	NCR	May 17, 2016~ May 25, 2016	NCR	Radiation (03CH03-SZ)
Turn Table	EM	EM1000	N/A	0~360 degree	NCR	May 17, 2016~ May 25, 2016	NCR	Radiation (03CH03-SZ)
Antenna Mast	EM	EM1000	N/A	1 m~4 m	NCR	May 17, 2016~ May 25, 2016	NCR	Radiation (03CH03-SZ)
EMI Test Receiver	R&S	ESR7	101404	9kHz~7GHz; Max 30dBm	Oct. 20, 2015	May 14, 2016	Oct. 19, 2016	Conduction (CO01-SZ)
AC LISN	EMCO	3816/2SH	00103892	9kHz~30MHz	Jan. 12, 2016	May 14, 2016	Jan. 11, 2017	Conduction (CO01-SZ)
AC LISN (for auxiliary equipment)	MessTec	3816/2SH	00103912	9kHz~30MHz	Jan. 12, 2016	May 14, 2016	Jan. 11, 2017	Conduction (CO01-SZ)
AC Power Source	Chroma	61602	616020000 891	100Vac~250Vac	Aug. 07, 2015	May 14, 2016	Aug. 06, 2016	Conduction (CO01-SZ)
Pulse Limiter	COM-POWER	LIT-153 Transient Limiter	53139	150kHz~30MHz	Oct. 20, 2015	May 14, 2016	Oct. 19, 2016	Conduction (CO01-SZ)

NCR: No Calibration Required



5 Uncertainty of Evaluation

Uncertainty of Conducted Emission Measurement (150kHz ~ 30MHz)

Measuring Uncertainty for a Level of Confidence of 95% ($U = 2Uc(y)$)	2.3dB
---	-------

Uncertainty of Radiated Emission Measurement (30 MHz ~ 1000 MHz)

Measuring Uncertainty for a Level of Confidence of 95% ($U = 2Uc(y)$)	5.0dB
---	-------

Uncertainty of Radiated Emission Measurement (1GHz ~ 18GHz)

Measuring Uncertainty for a Level of Confidence of 95% ($U = 2Uc(y)$)	4.8dB
---	-------

Uncertainty of Radiated Emission Measurement (18GHz ~ 40GHz)

Measuring Uncertainty for a Level of Confidence of 95% ($U = 2Uc(y)$)	5.0dB
---	-------



Appendix A. Conducted Test Results

A1 - DTS Part

Test Engineer:	Tiny You	Temperature:	24~26	°C
Test Date:	2016/5/17~2016/5/18	Relative Humidity:	50~53	%

TEST RESULTS DATA
6dB and 99% Occupied Bandwidth

2.4GHz Band								
Mod.	Data Rate	N _{TX}	CH.	Freq. (MHz)	99% Occupied BW (MHz)	6dB BW (MHz)	6dB BW Limit (MHz)	Pass/Fail
11b	1Mbps	1	1	2412	14.04	8.51	0.50	Pass
11b	1Mbps	1	6	2437	14.09	8.03	0.50	Pass
11b	1Mbps	1	11	2462	14.14	8.99	0.50	Pass
11g	6Mbps	1	1	2412	18.08	15.76	0.50	Pass
11g	6Mbps	1	6	2437	18.13	15.80	0.50	Pass
11g	6Mbps	1	11	2462	18.03	15.80	0.50	Pass
HT20	MCS0	1	1	2412	18.88	17.50	0.50	Pass
HT20	MCS0	1	6	2437	18.83	17.50	0.50	Pass
HT20	MCS0	1	11	2462	18.83	17.50	0.50	Pass

TEST RESULTS DATA
Peak Power Table

2.4GHz Band										
Mod.	Data Rate	N _{TX}	CH.	Freq. (MHz)	Peak Conducted Power (dBm)	Conducted Power Limit (dBm)	DG (dBi)	EIRP Power (dBm)	EIRP Power Limit (dBm)	Pass /Fail
11b	1Mbps	1	1	2412	16.87	30.00	1.20	18.07	36.00	Pass
11b	1Mbps	1	6	2437	16.74	30.00	1.20	17.94	36.00	Pass
11b	1Mbps	1	11	2462	16.41	30.00	1.20	17.61	36.00	Pass
11g	6Mbps	1	1	2412	22.29	30.00	1.20	23.49	36.00	Pass
11g	6Mbps	1	6	2437	22.18	30.00	1.20	23.38	36.00	Pass
11g	6Mbps	1	11	2462	21.86	30.00	1.20	23.06	36.00	Pass
HT20	MCS0	1	1	2412	20.62	30.00	1.20	21.82	36.00	Pass
HT20	MCS0	1	6	2437	20.38	30.00	1.20	21.58	36.00	Pass
HT20	MCS0	1	11	2462	20.46	30.00	1.20	21.66	36.00	Pass

TEST RESULTS DATA
Average Power Table
(Reporting Only)

2.4GHz Band						
Mod.	Data Rate	N _{TX}	CH.	Freq. (MHz)	Duty Factor (dB)	Average Conducted Power (dBm)
11b	1Mbps	1	1	2412	0.12	13.41
11b	1Mbps	1	6	2437	0.12	13.39
11b	1Mbps	1	11	2462	0.12	13.29
11g	6Mbps	1	1	2412	0.59	12.04
11g	6Mbps	1	6	2437	0.59	11.99
11g	6Mbps	1	11	2462	0.59	11.86
HT20	MCS0	1	1	2412	0.62	10.29
HT20	MCS0	1	6	2437	0.62	10.16
HT20	MCS0	1	11	2462	0.62	10.13

TEST RESULTS DATA
Peak Power Density

2.4GHz Band								
Mod.	Data Rate	N _{TX}	CH.	Freq. (MHz)	Peak PSD (dBm /3kHz)	DG (dBi)	Peak PSD Limit (dBm /3kHz)	Pass/Fail
11b	1Mbps	1	1	2412	-7.30	1.20	8.00	Pass
11b	1Mbps	1	6	2437	-7.35	1.20	8.00	Pass
11b	1Mbps	1	11	2462	-8.12	1.20	8.00	Pass
11g	6Mbps	1	1	2412	-11.97	1.20	8.00	Pass
11g	6Mbps	1	6	2437	-12.49	1.20	8.00	Pass
11g	6Mbps	1	11	2462	-12.83	1.20	8.00	Pass
HT20	MCS0	1	1	2412	-13.98	1.20	8.00	Pass
HT20	MCS0	1	6	2437	-14.48	1.20	8.00	Pass
HT20	MCS0	1	11	2462	-14.41	1.20	8.00	Pass



Appendix B. Radiated Spurious Emission

15C 2.4GHz 2400~2483.5MHz

WIFI 802.11b (Band Edge @ 3m)

WIFI	Note	Frequency	Level	Over	Limit	Read	Antenna	Cable	Preamp	Ant	Table	Peak	Pol.
Ant.				Limit	Line	Level	Factor	Loss	Factor	Pos	Pos	Avg.	
1		(MHz)	(dBμV/m)	(dB)	(dBμV/m)	(dBμV)	(dB/m)	(dB)	(dB)	(cm)	(deg)	(P/A)	(H/V)
802.11b CH 01 2412MHz		2386.05	52.14	-21.86	74	55.12	27.25	4.79	35.02	178	206	P	H
		2385.15	42.62	-11.38	54	45.66	27.19	4.79	35.02	178	206	A	H
	*	2412	102.89	-	-	105.76	27.31	4.82	35	178	206	P	H
	*	2412	99.49	-	-	102.36	27.31	4.82	35	178	206	A	H
		2371.56	53.5	-20.5	74	56.54	27.19	4.79	35.02	150	219	P	V
		2385.42	44.89	-9.11	54	47.93	27.19	4.79	35.02	150	219	A	V
	*	2412	107.2	-	-	110.07	27.31	4.82	35	150	219	P	V
	*	2412	103.98	-	-	106.85	27.31	4.82	35	150	219	A	V
802.11b CH 06 2437MHz		2372.1	50.76	-23.24	74	53.8	27.19	4.79	35.02	237	213	P	H
		2388.3	41.78	-12.22	54	44.76	27.25	4.79	35.02	237	213	A	H
	*	2437	102.56	-	-	105.29	27.42	4.82	34.97	237	213	P	H
	*	2437	98.78	-	-	101.51	27.42	4.82	34.97	237	213	A	H
		2497.92	51.48	-22.52	74	53.89	27.6	4.89	34.9	237	213	P	H
		2489.68	41.7	-12.3	54	44.13	27.6	4.89	34.92	237	213	A	H
		2383.98	52.1	-21.9	74	55.14	27.19	4.79	35.02	150	216	P	V
		2385.69	43.5	-10.5	54	46.48	27.25	4.79	35.02	150	216	A	V
	*	2437	107.69	-	-	110.42	27.42	4.82	34.97	150	216	P	V
	*	2437	104.46	-	-	107.19	27.42	4.82	34.97	150	216	A	V
		2498.8	54.32	-19.68	74	56.73	27.6	4.89	34.9	150	216	P	V
	2489.8	43.77	-10.23	54	46.2	27.6	4.89	34.92	150	216	A	V	



802.11b CH 11 2462MHz	*	2462	102.03	-	-	104.65	27.48	4.85	34.95	250	209	P	H
	*	2462	98.92	-	-	101.54	27.48	4.85	34.95	250	209	A	H
		2490.56	52.08	-21.92	74	54.51	27.6	4.89	34.92	250	209	P	H
		2484.6	42.03	-11.97	54	44.56	27.54	4.85	34.92	250	209	A	H
	*	2462	106.63	-	-	109.25	27.48	4.85	34.95	173	215	P	V
	*	2462	103.35	-	-	105.97	27.48	4.85	34.95	173	215	A	V
		2490.64	54.47	-19.53	74	56.9	27.6	4.89	34.92	173	215	P	V
		2484.72	44.64	-9.36	54	47.17	27.54	4.85	34.92	173	215	A	V
Remark	1. No other spurious found. 2. All results are PASS against Peak and Average limit line.												



15C 2.4GHz 2400~2483.5MHz
WIFI 802.11b (Harmonic @ 3m)

Table with 13 columns: WIFI, Note, Frequency, Level, Over, Limit, Read, Antenna, Cable, Preamp, Ant, Table, Peak, Pol. It contains test results for channels 01, 06, and 11, and a Remark section at the bottom.



**15C 2.4GHz 2400~2483.5MHz
WIFI 802.11g (Band Edge @ 3m)**

WIFI	Note	Frequency	Level	Over	Limit	Read	Antenna	Cable	Preamp	Ant	Table	Peak	Pol.
Ant.				Limit	Line	Level	Factor	Loss	Factor	Pos	Pos	Avg.	
1		(MHz)	(dBμV/m)	(dB)	(dBμV/m)	(dBμV)	(dB/m)	(dB)	(dB)	(cm)	(deg)	(P/A)	(H/V)
802.11g CH 01 2412MHz		2387.76	63.93	-10.07	74	66.91	27.25	4.79	35.02	235	210	P	H
		2390	50.47	-3.53	54	53.43	27.25	4.79	35	235	210	A	H
	*	2412	104.42	-	-	107.29	27.31	4.82	35	235	210	P	H
	*	2412	96.8	-	-	99.67	27.31	4.82	35	235	210	A	H
		2388.48	67.1	-6.9	74	70.08	27.25	4.79	35.02	150	219	P	V
		2390	52.82	-1.18	54	55.78	27.25	4.79	35	150	219	A	V
	*	2412	107.08	-	-	109.95	27.31	4.82	35	150	219	P	V
	*	2412	99.42	-	-	102.29	27.31	4.82	35	150	219	A	V
802.11g CH 06 2437MHz		2388.84	54.12	-19.88	74	57.1	27.25	4.79	35.02	250	16	P	H
		2389.56	41.54	-12.46	54	44.52	27.25	4.79	35.02	250	16	A	H
	*	2437	102.55	-	-	105.28	27.42	4.82	34.97	250	16	P	H
	*	2437	95.26	-	-	97.99	27.42	4.82	34.97	250	16	A	H
		2484.96	51.9	-22.1	74	54.43	27.54	4.85	34.92	250	16	P	H
		2484	42.16	-11.84	54	44.69	27.54	4.85	34.92	250	16	A	H
		2382.45	60.58	-13.42	74	63.62	27.19	4.79	35.02	169	27	P	V
		2389.92	44.92	-9.08	54	47.88	27.25	4.79	35	169	27	A	V
	*	2437	109.04	-	-	111.77	27.42	4.82	34.97	169	27	P	V
	*	2437	101.49	-	-	104.22	27.42	4.82	34.97	169	27	A	V
		2491.32	59.56	-14.44	74	61.99	27.6	4.89	34.92	169	27	P	V
		2483.6	44.68	-9.32	54	47.21	27.54	4.85	34.92	169	27	A	V



802.11g CH 11 2462MHz	*	2462	103.06	-	-	105.68	27.48	4.85	34.95	230	211	P	H
	*	2462	95.74	-	-	98.36	27.48	4.85	34.95	230	211	A	H
		2483.56	64.09	-9.91	74	66.62	27.54	4.85	34.92	230	211	P	H
		2483.6	49.64	-4.36	54	52.17	27.54	4.85	34.92	230	211	A	H
	*	2462	106.64	-	-	109.26	27.48	4.85	34.95	150	196	P	V
	*	2462	99.03	-	-	101.65	27.48	4.85	34.95	150	196	A	V
		2483.8	64.83	-9.17	74	67.36	27.54	4.85	34.92	150	196	P	V
		2483.52	52.9	-1.1	54	55.43	27.54	4.85	34.92	150	196	A	V

Remark	<ol style="list-style-type: none"> No other spurious found. All results are PASS against Peak and Average limit line.
--------	---



15C 2.4GHz 2400~2483.5MHz

WIFI 802.11g (Harmonic @ 3m)

WIFI	Note	Frequency	Level	Over	Limit	Read	Antenna	Cable	Preamp	Ant	Table	Peak	Pol.
Ant.				Limit	Line	Level	Factor	Loss	Factor	Pos	Pos	Avg.	
1		(MHz)	(dBμV/m)	(dB)	(dBμV/m)	(dBμV)	(dB/m)	(dB)	(dB)	(cm)	(deg)	(P/A)	(H/V)
802.11g		4824	43.95	-30.05	74	64.32	31.05	6.97	58.39	250	0	P	H
CH 01		4824	39.3	-34.7	74	59.67	31.05	6.97	58.39	250	0	P	V
2412MHz													
802.11g		4874	42.72	-31.28	74	63.27	31.12	6.99	58.66	250	0	P	H
CH 06		7311	47.12	-26.88	74	61.56	35.96	8.22	58.62	150	0	P	H
2437MHz		4874	40.07	-33.93	74	60.62	31.12	6.99	58.66	250	0	P	V
		7311	48.86	-25.14	74	63.3	35.96	8.22	58.62	150	0	P	V
802.11g		4924	43.06	-30.94	74	63.39	31.19	7	58.52	250	0	P	H
CH 11		7386	46.84	-27.16	74	61.03	36.08	8.27	58.54	150	0	P	H
2462MHz		4924	42.48	-31.52	74	62.81	31.19	7	58.52	250	0	P	V
		7386	48.72	-25.28	74	62.91	36.08	8.27	58.54	150	0	P	V
Remark	1. No other spurious found. 2. All results are PASS against Peak and Average limit line.												



15C 2.4GHz 2400~2483.5MHz
WIFI 802.11n HT20 (Band Edge @ 3m)

Table with 14 columns: WIFI, Note, Frequency, Level, Over, Limit, Read, Antenna, Cable, Preamp, Ant, Table, Peak, Pol. It contains two main sections of data for 802.11n HT20 channels.



802.11n HT20 CH 11 2462MHz	*	2462	102.26	-	-	104.88	27.48	4.85	34.95	250	207	P	H
	*	2462	94.72	-	-	97.34	27.48	4.85	34.95	250	207	A	H
		2483.96	62.52	-11.48	74	65.05	27.54	4.85	34.92	250	207	P	H
		2483.52	50.49	-3.51	54	53.02	27.54	4.85	34.92	250	207	A	H
	*	2462	104.91	-	-	107.53	27.48	4.85	34.95	171	221	P	V
	*	2462	97.51	-	-	100.13	27.48	4.85	34.95	171	221	A	V
		2483.84	65.04	-8.96	74	67.57	27.54	4.85	34.92	171	221	P	V
	2483.52	52.73	-1.27	54	55.26	27.54	4.85	34.92	171	221	A	V	
Remark	1. No other spurious found. 2. All results are PASS against Peak and Average limit line.												



15C 2.4GHz 2400~2483.5MHz
WIFI 802.11n HT20 (Harmonic @ 3m)

WIFI	Note	Frequency	Level	Over	Limit	Read	Antenna	Cable	Preamp	Ant	Table	Peak	Pol.
Ant.				Limit	Line	Level	Factor	Loss	Factor	Pos	Pos	Avg.	
1		(MHz)	(dBμV/m)	(dB)	(dBμV/m)	(dBμV)	(dB/m)	(dB)	(dB)	(cm)	(deg)	(P/A)	(H/V)
802.11n HT20 CH 01 2412MHz		4824	40.96	-33.04	74	61.33	31.05	6.97	58.39	250	0	P	H
		4824	39.35	-34.65	74	59.72	31.05	6.97	58.39	250	0	P	V
802.11n HT20 CH 06 2437MHz		4874	41.06	-32.94	74	61.61	31.12	6.99	58.66	250	0	P	H
		7311	47.21	-26.79	74	61.65	35.96	8.22	58.62	150	0	P	H
		4874	38.58	-35.42	74	59.13	31.12	6.99	58.66	250	0	P	V
		7311	48.67	-25.33	74	63.11	35.96	8.22	58.62	150	0	P	V
802.11n HT20 CH 11 2462MHz		4924	42.04	-31.96	74	62.37	31.19	7	58.52	250	0	P	H
		7386	47.7	-26.3	74	61.89	36.08	8.27	58.54	150	0	P	H
		4924	39.82	-34.18	74	60.15	31.19	7	58.52	250	0	P	V
		7386	49.82	-24.18	74	64.01	36.08	8.27	58.54	150	0	P	V
Remark	1. No other spurious found. 2. All results are PASS against Peak and Average limit line.												



15C Emission below 1GHz

2.4GHz WIFI 802.11g (LF)

WIFI	Note	Frequency	Level	Over	Limit	Read	Antenna	Cable	Preamp	Ant	Table	Peak	Pol.
Ant.				Limit	Line	Level	Factor	Loss	Factor	Pos	Pos	Avg.	
1		(MHz)	(dBμV/m)	(dB)	(dBμV/m)	(dBμV)	(dB/m)	(dB)	(dB)	(cm)	(deg)	(P/A)	(H/V)
2.4GHz 802.11g LF		176.47	31.89	-11.61	43.5	45.04	16.61	1.57	31.33	-	-	P	H
		292.87	34.65	-11.35	46	44.48	19.55	1.94	31.32	-	-	P	H
		369.5	31.14	-14.86	46	38.68	21.69	2.04	31.27	-	-	P	H
		749.74	41.27	-4.73	46	43.8	25.85	2.85	31.23	100	300	P	H
		837.04	39.68	-6.32	46	41.41	26.53	2.99	31.25	-	-	P	H
		891.36	37.97	-8.03	46	39.14	27.02	3.09	31.28	-	-	P	H
		97.9	35.09	-8.41	43.5	47.32	17.98	1.38	31.59	-	-	P	V
		176.47	32.03	-11.47	43.5	45.18	16.61	1.57	31.33	-	-	P	V
		360.77	30.09	-15.91	46	37.87	21.45	2.04	31.27	-	-	P	V
		500.45	33.53	-12.47	46	38.37	23.9	2.41	31.15	-	-	P	V
		837.04	37.48	-8.52	46	39.21	26.53	2.99	31.25	-	-	P	V
	944.71	38.04	-7.96	46	38.75	27.41	3.15	31.27	100	200	P	V	
Remark	1. No other spurious found. 2. All results are PASS against limit line.												



Note symbol

*	Fundamental Frequency which can be ignored. However, the level of any unwanted emissions shall not exceed the level of the fundamental frequency per 15.209(c).
!	Test result is over limit line.
P/A	Peak or Average
H/V	Horizontal or Vertical



A calculation example for radiated spurious emission is shown as below:

WIFI	Note	Frequency	Level	Over	Limit	Read	Antenna	Cable	Preamp	Ant	Table	Peak	Pol.
Ant.				Limit	Line	Level	Factor	Loss	Factor	Pos	Pos	Avg.	
1+2		(MHz)	(dBμV/m)	(dB)	(dBμV/m)	(dBμV)	(dB/m)	(dB)	(dB)	(cm)	(deg)	(P/A)	(H/V)
802.11b		2390	55.45	-18.55	74	54.51	32.22	4.58	35.86	103	308	P	H
CH 01													
2412MHz		2390	43.54	-10.46	54	42.6	32.22	4.58	35.86	103	308	A	H

- Level(dBμV/m) =
Antenna Factor(dB/m) + Cable Loss(dB) + Read Level(dBμV) - Preamp Factor(dB)
- Over Limit(dB) = Level(dBμV/m) – Limit Line(dBμV/m)

For Peak Limit @ 2390MHz:

- Level(dBμV/m)
= Antenna Factor(dB/m) + Cable Loss(dB) + Read Level(dBμV) - Preamp Factor(dB)
= 32.22(dB/m) + 4.58(dB) + 54.51(dBμV) – 35.86 (dB)
= 55.45 (dBμV/m)
- Over Limit(dB)
= Level(dBμV/m) – Limit Line(dBμV/m)
= 55.45(dBμV/m) – 74(dBμV/m)
= -18.55(dB)

For Average Limit @ 2390MHz:

- Level(dBμV/m)
= Antenna Factor(dB/m) + Cable Loss(dB) + Read Level(dBμV) - Preamp Factor(dB)
= 32.22(dB/m) + 4.58(dB) + 42.6(dBμV) – 35.86 (dB)
= 43.54 (dBμV/m)
- Over Limit(dB)
= Level(dBμV/m) – Limit Line(dBμV/m)
= 43.54(dBμV/m) – 54(dBμV/m)
= -10.46(dB)

Both peak and average measured complies with the limit line, so test result is “PASS”.



Appendix C. Duty Cycle Plots

Band	Duty Cycle(%)	T(ms)	1/T(kHz)	VBW Setting
802.11b	97.25	12.39	0.08	100Hz
802.11g	87.39	2.08	0.48	1kHz
802.11n HT20	86.61	1.94	1kHz	

802.11b

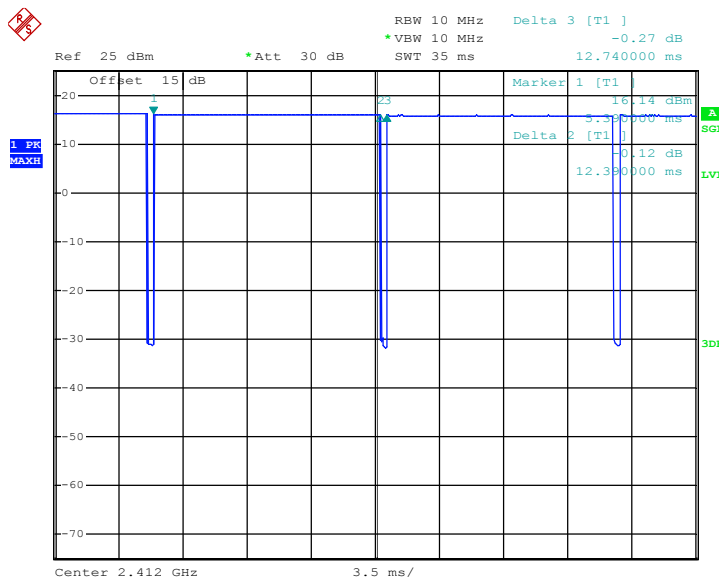

Date: 17.MAY.2016 16:43:30



802.11g

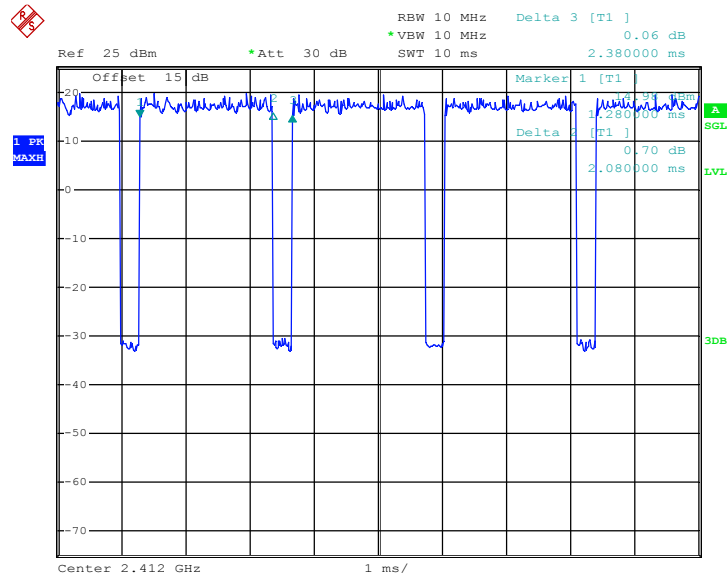

Date: 17.MAY.2016 16:54:42

2.4GHz 802.11n HT20

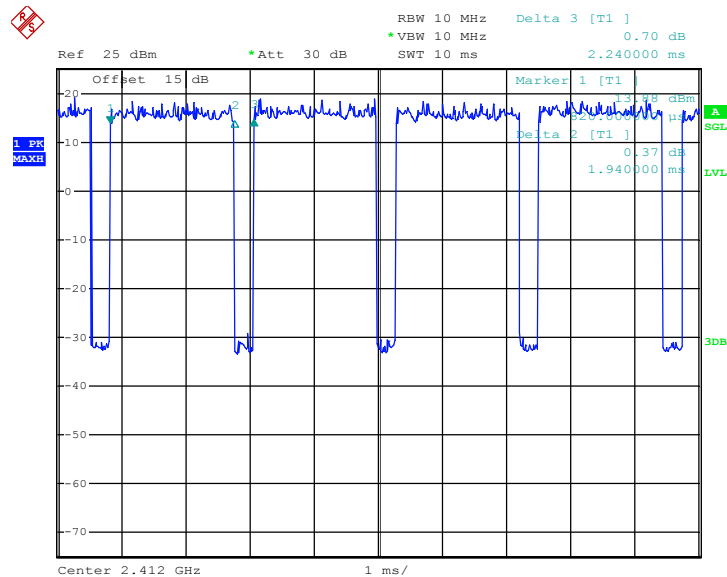

Date: 17.MAY.2016 17:11:03