



VHRP-1200

**BEACON**  
5-IN-1  
Turntable System



## Instruction Manual

Please read carefully before use and keep for future reference

# WARNING



**CAUTION:** To reduce the risk of fire or electric shock, do not expose this appliance to rain or moisture.



**WARNING:** Invisible laser radiation when open and interlock failed or defeated. Avoid direct exposure to laser beam.



This equipment is a Class II or double insulated electrical appliance. It has been designed in such a way that it does not require a safety connection to electrical earth.



Correct Disposal of this product. This marking indicates that this product should not be disposed with other household wastes throughout the EU. To prevent possible harm to the environment or human health from uncontrolled waste disposal, recycle it responsibly to promote the sustainable reuse of material resources. To return your used device, please use the return and collection systems or contact the retailer where the product was purchased. They can take this product for environmentally safe recycling.

## Important Safety Instructions

1. Read these instructions – All the safety and operating instructions should be read before this product is operated.
2. Keep these instructions – The safety and operating instructions should be retained for future reference.
3. Heed all warnings – All warnings on the appliance and in the operating instructions should be adhered to.
4. Follow all instructions – All operating and use instructions should be followed.
5. Do not use this apparatus near water – The appliance should not be used near water or moisture – for example, in a wet basement or near a swimming pool, and the like.
6. Clean only with a dry cloth.
7. Do not block any ventilation openings. Install in accordance with the manufacturer's instructions.
8. Do not install near any heat sources such as radiators, heat registers, stoves, or other apparatus (including amplifiers) that produce heat.
9. Protect the power cord from being walked on or pinched particularly at the plugs, power outlets, and at the point where they exit from the apparatus.
10. Only use attachments/accessories specified by the manufacturer.
11. Use only with the cart, stand, tripod, bracket, or table specified by the manufacturer, or sold with the apparatus. When a cart or rack is used, use caution when moving the cart/apparatus combination to avoid injury from tip-over.
12. Unplug the apparatus during lighting storms or when unused for long periods of time.
13. Refer all servicing to qualified personnel. Servicing is required when the apparatus has been damaged in any way, such as power supply cord or plug is damaged, liquid has been spilled or objects have fallen into the apparatus has been exposed to rain or moisture, does not operate normally, or has been dropped.
14. The mains plug is used as disconnect device, the disconnect device shall remain readily operable.
15. **WARNING:** To reduce the risk of fire or electric shock, do not expose this apparatus to rain or moisture. The apparatus shall not be exposed to dripping or splashing and that no objects filled with liquids, such as vases, shall not be placed on apparatus.
16. The use of the equipment in moderate climate.
17. The ventilation should not be impeded by covering the ventilation openings with items, such as newspapers, tablecloths, curtains, etc.
18. Do not place open flame sources, such as lighted candles, on the apparatus.
19. The symbol  indicates AC voltage.
20. **CAUTION,** These servicing instructions are for use by qualified service personnel only. To reduce the risk of electric shock do not perform any servicing other than that contained in the operating instructions unless you are qualified to do so.



This lightning flash with arrowhead symbol within an equilateral triangle is intended to alert the user to the presence of non-insulated "dangerous voltage" within the product's enclosure that may be of sufficient magnitude to constitute a risk of electric shock. Warning: To reduce the risk of electric shock, do not remove cover (or back) as there are no user-serviceable parts inside. Refer servicing to qualified personnel. The exclamation point within and equilateral triangle is intended to alert the user to the presence of important operating and maintenance instructions in the literature accompanying the appliance.

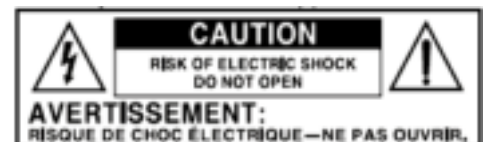

# TABLE OF CONTENTS

|                                      |    |
|--------------------------------------|----|
| FEATURES .....                       | 4  |
| SPECIFICATIONS.....                  | 4  |
| PRODUCT OVERVIEW.....                | 5  |
| SETUP & BASIC OPERATION.....         | 7  |
| USING THE FM RADIO.....              | 7  |
| PLAYING A RECORD.....                | 8  |
| CONNECTING TO BLUETOOTH® .....       | 9  |
| CONNECTING TO EXTERNAL SYSTEMS ..... | 10 |
| FCC NOTICE .....                     | 10 |
| CAUTION ON MODIFICATION .....        | 10 |
| SUPPORT .....                        | 13 |

# FEATURES

BEACON 5-in-1 Turntable is ready to play your vinyl records & listen to your favorite radio stations with the built in 3-Speed Turntable & FM Radio! The Dual Bluetooth feature allows streaming of your vinyl records to an external Bluetooth Speaker or plays music from your Smart Device through the Beacon's built in Speakers. The 3.5mm Aux Input & RCA Audio Output allow for even more additional Playback options. Blue Accent Lighting gives the Beacon a great '90's feel.

- 3-speed record player will play 33 1/3, 45, 78 rpm records
- Bluetooth In connectivity allows you to stream music from another source up to 33 feet away
- Bluetooth Out connectivity allows you to stream vinyl playback through any external Bluetooth Speaker
- FM Radio
- 3.5mm Aux Input for additional connectivity
- RCA Audio Output for additional connectivity
- LED Accent lighting
- Built in Stereo Speakers for playback convenience

# SPECIFICATIONS

|                                  |  |
|----------------------------------|--|
| Product Name                     | BEACON (5-IN-1 Turntable System)                     |
| Turntable Speed                  | 33 1/3, 45, 78 RPM                                   |
| FM Frequency Range               | 87.5 – 108 MHz                                       |
| FM Station Memory                | Up to 20   |
| Bluetooth® Version               | V5.1   |
| Bluetooth® Transmission Distance | Up to 30 Feet (10 Meters)*                           |
| Rated Frequency                  | 2.40GHz  |
| Input                            | Aux In (3.5mm)                                       |
| Output                           | RCA Stereo Audio                                     |
| Built-in Speaker                 | 2" x 2   |
| Power Output                     | 1W x 2 RMS   |
| Power Source                     | AC/DC 100-240V 50-60Hz 9V/0.8A                       |
| Accessories Included             | UL Approved Adaptor, User Manual, Quick Set Up Guide |

\*Distance may vary depending on any objects or interference between devices.

SPECIFICATIONS AND ACCESSORIES ARE SUBJECT TO CHANGE WITHOUT NOTICE

# PRODUCT OVERVIEW

## MAIN FEATURES

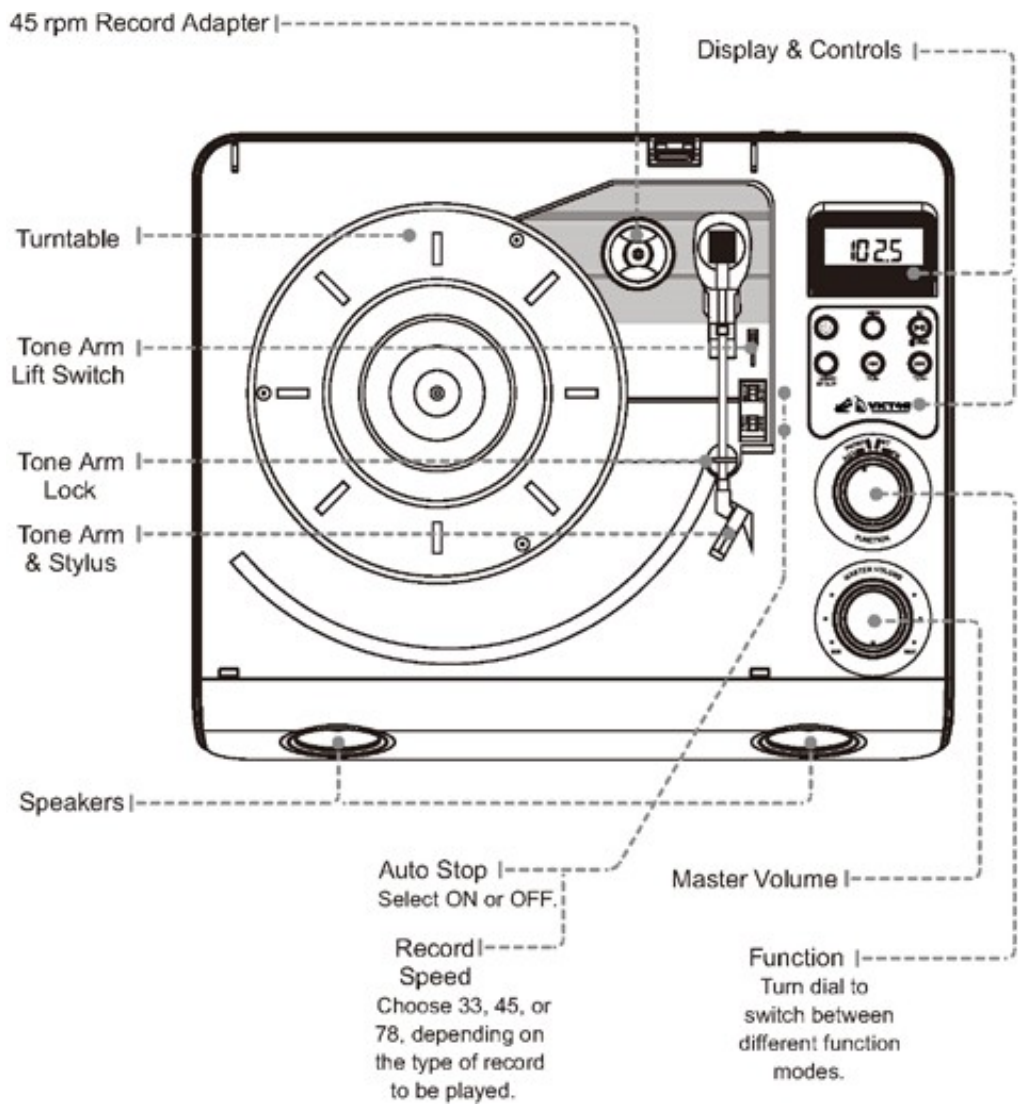

## REAR INPUTS

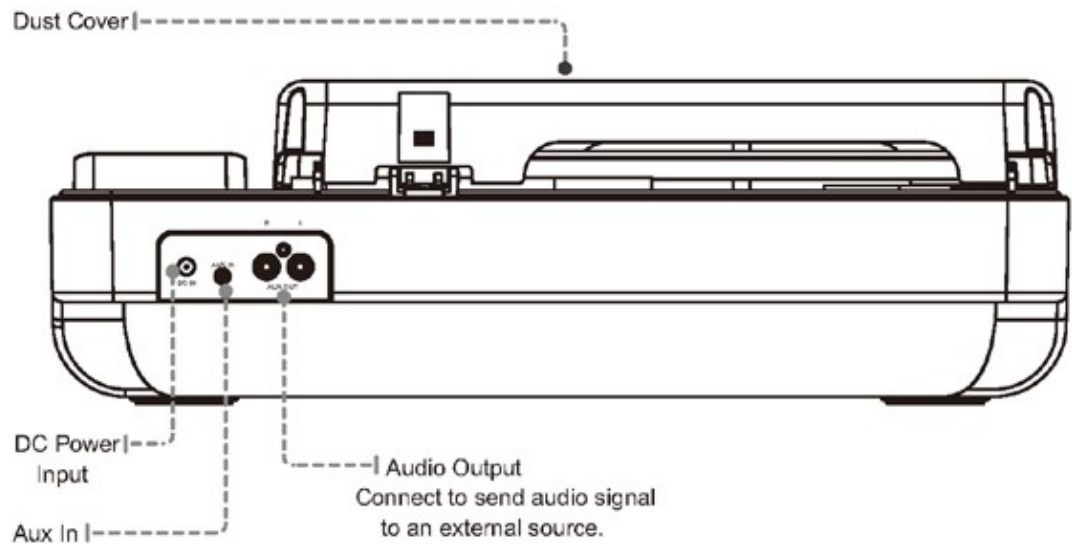

**Power** 

Press to power the unit ON or OFF.

**Mem**

Press to begin programming FM memory presets.

**M+/Play/Pause/  Pair**

In FM mode, press to cycle FM Memory Presets.

Press to play/pause an audio track.

In BT mode, press to begin pairing to a Bluetooth device.

**Lights/BT out**

Press to activate LED light effects.

Press and hold button to BT Out

**Skip Rev  Tun -**

Press to skip back an audio track.

In FM Mode, press to adjust down for FM tuning.

**Skip Fwd  Tun +**

Press to skip ahead an audio track.

In FM Mode, press to adjust up for FM tuning.

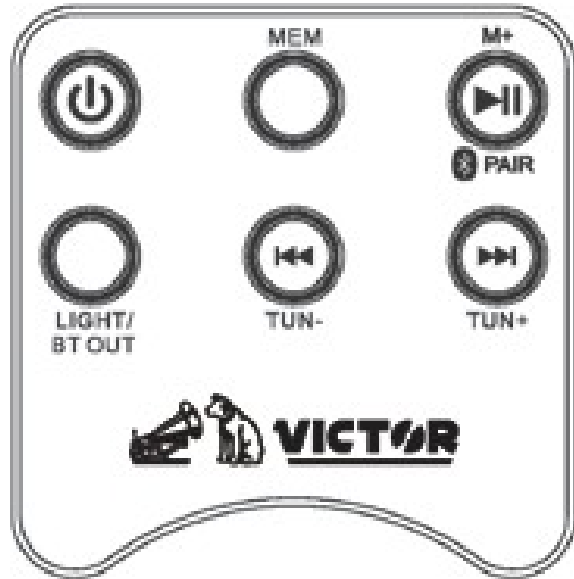
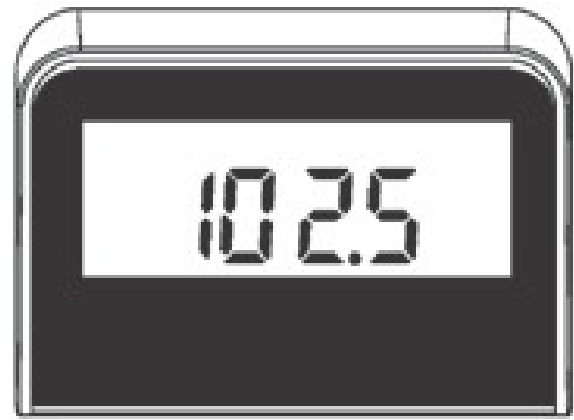

# SETUP & BASIC OPERATION

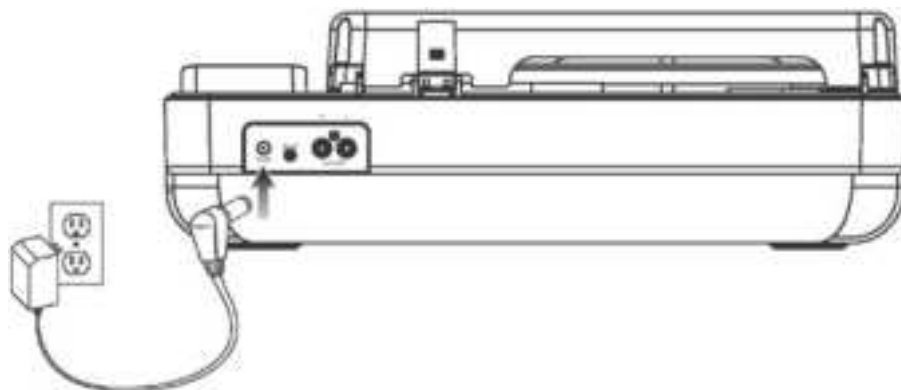

## Connect to Power Source

1. Plug the small end of the power cord into the POWER Input on the back of the unit, and the large plug into a standard wall power outlet.
2. Press the **Power**  button to turn on the unit





# USING THE FM RADIO

## Tuning the FM Radio

1. Press the Power  button to turn on the unit and set the **Function Dial** to **FM**.
2. The FM icon will turn on and the frequency will show on the LCD display
3. Press and hold the **TUN+** or **TUN-** button to search for the previous/next available FM station.
4. If the reception is poor, try Manual Tuning to fine-tune the station. Tap **TUN+** or **TUN-** button briefly to manually tune through the frequency band.
5. Adjust the **MASTER VOLUME** to obtain the desired volume level.
6. When you have finished listening, press the Power  button to turn the radio off.

## To set FM Radio presets

The unit allows you to store up to 20 FM stations for easy recall at any time.

1. Press the Power  button to turn on the unit and set the Function Dial to FM.
2. Press the TUN+ or TUN- button to select the desired station.
3. Press and hold the MEM button, the preset channel number "P01" will blink on the display.
4. Tap the  or  button to select a preset location (P01-P20)
5. Press the MEM button again to confirm the preset.
6. Repeat steps 2 through 5 to preset up to 20 stations

## Recall a preset station

To recall one of the preset stations already programmed, tap the M+ button repeatedly until you reach the desired preset number/radio station.

# PLAYING A RECORD

It is recommended that you use extreme care when manipulating the tone arm, stylus, and other components of this turntable. These parts are very sensitive and can easily break or become damaged if they are carelessly handled.

1. Press the **Power**  button to turn on the unit and set the Function Dial to **Phono**.
2. Lift the turntable dust cover, remove the cap that protects the stylus, and release the lock that holds the Tone Arm in place in its resting position.

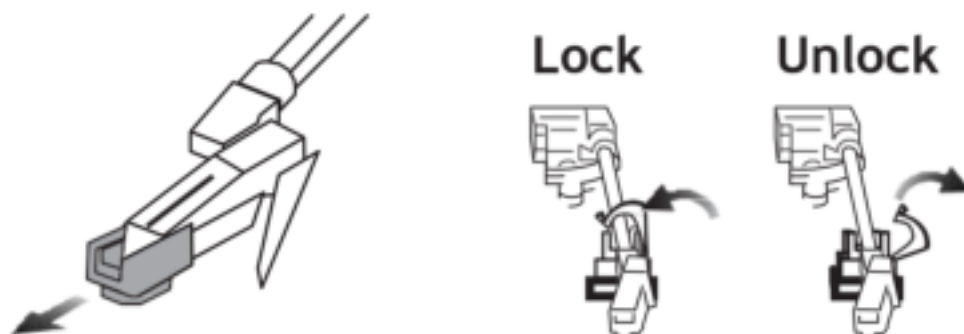

3. Select the correct turntable speed based on the type of record you wish to play and place the record on the turntable. If you are playing a 45 rpm record, use the included adapter and place it between the turntable and the record.

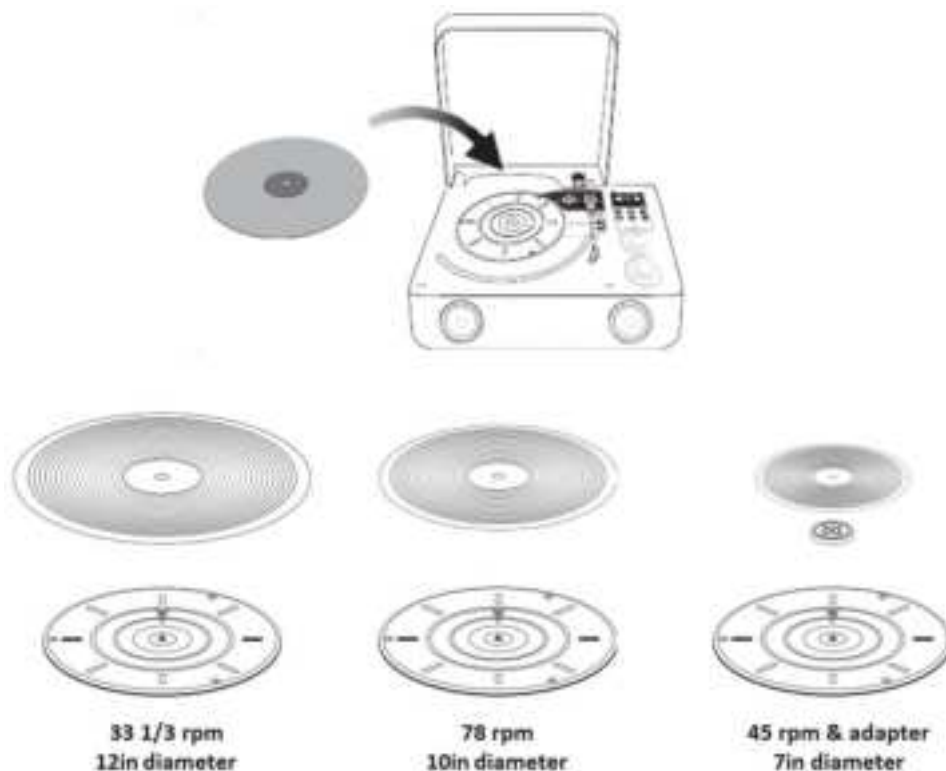









4. Use the **Tone Arm Lift Switch** to raise the **Tone Arm** from its holder.
5. Using your hand, gently swing the **Tone Arm** into the desired location over the record. The turntable will start spinning as the Tone Arm is moved into position.
6. Use the **Tone Arm Lift Switch** to safely lower the stylus onto the record.
7. Using the Lift Switch instead of your hand will reduce the chance of accidentally damaging the record or the stylus.
8. Slide the **Auto Stop Switch** to **ON** to enable the Auto Stop feature. When the record is finished playing, it will automatically stop the turntable.
9. Use the **Lift Switch** to raise the stylus off of the record, and gently return the Tone Arm to the catch by hand. *Note:* Some records place their Auto Stop area outside of the range of this unit. In these cases, the record will stop playing before the last track is reached.
10. Set the Auto Stop Switch to OFF and use the Tone Arm Lift Switch to safely raise the stylus off the record when the end of the record has been reached.
11. When not in use, secure and lock the Tone Arm in its resting position and replace the protective shroud over the stylus. This will minimize the risk of accidental damage to these sensitive parts.

## CONNECTING TO BLUETOOTH®

### Pairing a Bluetooth® enabled Device with the Turntable



1. Press the **Power**  button to turn on the unit and set the Function Dial to **BT**.
2. Press and hold the  PAIR button, the Bluetooth indicator  will blink. The unit will go into Pairing/Discoverable mode.
3. The Bluetooth® indicator  will turn on and blink on the LCD DISPLAY. When pairing, remain within 3 feet of the unit.
4. Turn on the Bluetooth® function of your device and search for nearby Bluetooth® devices.
5. Select "**VICTOR VHRP-1200**" from the device list when it appears on your device screen. If required, enter the pass code "0000" to pair (link) Turntable with your device.
6. When successfully paired and connected, an audible chime will sound and Bluetooth indicator  will light steadily on the LDC DISPLAY.

*After initial pairing, the unit will stay paired unless unpaired manually by the user or erased due to a reset of the device. If your device should become unpaired or you find it is unable to connect, repeat the above steps or press & hold the  **Pair** button again.*

### Playing Audio Wirelessly

1. After pairing to a Bluetooth device, use the controls on your Device to play audio.
2. Use the controls on the connected Bluetooth Device or the controls on the turntable.
3. Audio played through the connected Bluetooth device will now be heard through the speakers.

## Stream Music from the Turntable to an external Bluetooth® Speakers

1. POWER on the unit, set **FUNCTION** dial to phono mode.
2. Press and hold **BT OUT** button. The unit enters pairing mode and BT indicator  blinks.
3. Turn on your Bluetooth speakers and begin searching for speakers.
  - a. If you have several Bluetooth receivers, turn off receivers not in use to avoid Turntable linking to other unwanted Bluetooth enabled devices.
  - b. The effective distance between your external device and turntable is 33 feet (10 meters).
4. Turntable will auto scan and pair with your Bluetooth receiver nearby, BT indicator  will stop blinking to indicate a connection has been established.
5. Play music on Turntable in Phono or AUX mode. You will no longer hear sound on the turntable speakers. Instead, music will be played on your connected Bluetooth® device.
6. Press and hold the **BT OUT** button when you finish listening in Bluetooth transmitter mode, BT indicator will be off and unit speaker will sound again.

### Notes:

- When Bluetooth Receive/In or FM Radio modes are in use, the Bluetooth Transmit/Out function is disabled.
- There will be a brief sound delay when enabling the Bluetooth Transmit/Out function
- Bluetooth Out (Transmitter) can only pair with Bluetooth receiver such as headphones or speakers for streaming wirelessly. Use your Bluetooth device volume control if necessary.

# CONNECTING TO EXTERNAL SYSTEMS

## RCA Audio Output

Requires RCA audio cables (red/white, not included). Use to connect the turntable to an external stereo, television, or other source.

1. Connect RCA audio cables to the RCA Audio Output on the back of the turntable, and the other end to the audio input of an external stereo system.
2. Adjust the external stereo system to accept input from the turntable.
3. Audio played through the turntable will now be heard through the connected stereo system.

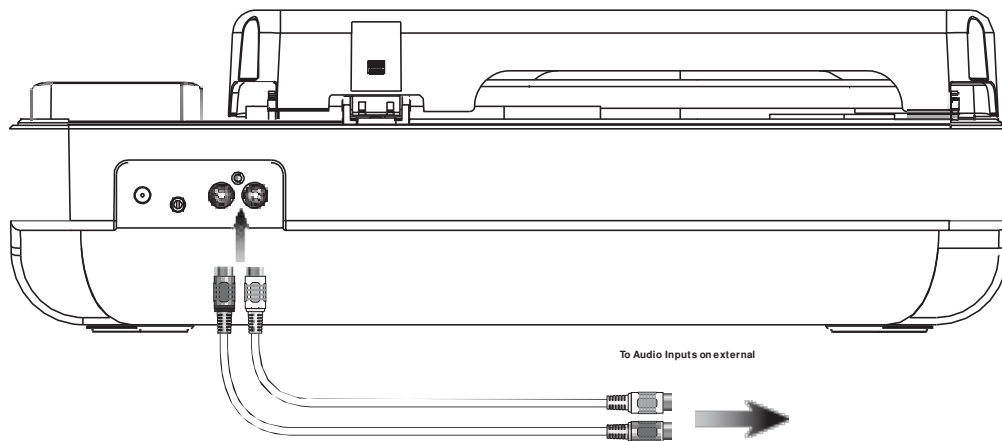

### Using the AUX IN (3.5mm Audio Input)

Requires 3.5 mm audio input cable (not included).

1. Plug a 3.5 mm audio input cable into the **Aux In** jack on the back of the turntable and the other end connect to the audio output/headphone output on a MP3 Player or other audio source.
2. Set the FUNCTION Dial to **AUX** and use the controls on your connected music player to select and play audio.
3. Audio played through the connected device will now be heard through the speakers.

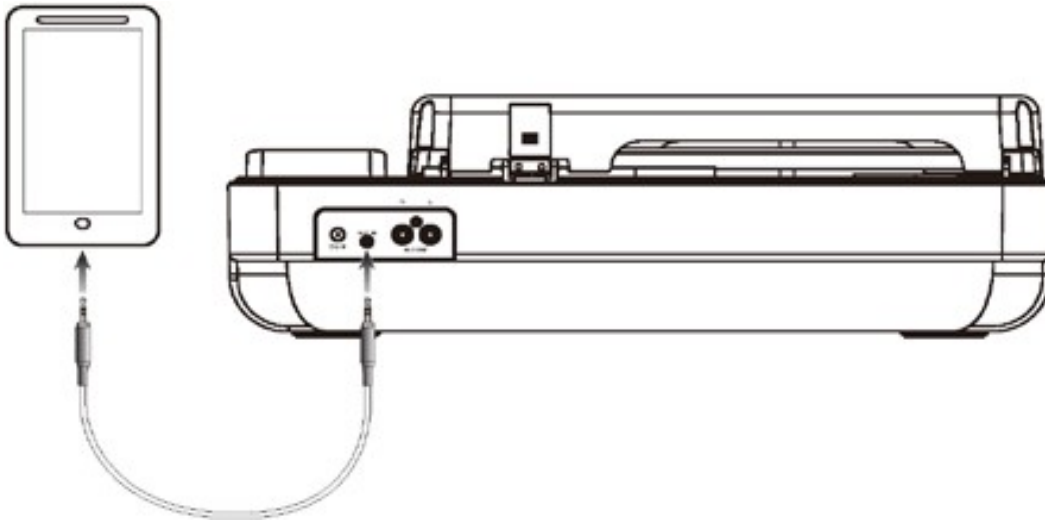

# FCC NOTICE

This device complies with Part 15 of the FCC Rules. Operation is subject to the following two conditions: (1) this device may not cause harmful interference, and (2) this device must accept any interference received, including that may cause undesired operation.

NOTE: This equipment has been tested and found to comply with the limits for a Class B digital device, pursuant to Part 15 of the FCC Rules. These limits are designed to provide reasonable protection against harmful interference in a residential installation. This equipment generates, uses, and can radiate radio frequency energy and, if not installed and used in accordance with the instructions, may cause harmful interference to radio communications. However, there is no guarantee that interference will not occur in a particular installation. If this equipment does cause harmful interference to radio or television reception, which can be determined by turning the equipment on and off, the user is encouraged to try to correct the interference by one or more of the following measures:

- Reorient or relocate the receiving antenna.
- Increase the separation between the equipment and receiver.
- Connect the equipment into an outlet on a circuit different from that to which the receiver is connected .
- Consult the dealer or an experienced radio/TV technician for help.

WARNING: Any changes or modifications not expressly approved by the party responsible for compliance could void the user's authority to operate this equipment.

The device must not be colocated or operating in conjunction with any other antenna or transmitter.

To maintain compliance with the FCC's RF exposure guidelines, place the product at least 20cm from nearby persons.

# ISED STATEMENT

This device contains licence-exempt transmitter(s)/receiver(s) that comply with Innovation, Science and Economic Development Canada's licence-exempt RSS(s). Operation is subject to the following two conditions:

(1) This device may not cause interference.

(2) This device must accept any interference, including interference that may cause undesired operation of the device.

L'émetteur/récepteur exempt de licence contenu dans le présent appareil est conforme aux CNR d'Innovation, Sciences et Développement économique Canada applicables aux appareils radio exempts de licence. L'exploitation est autorisée aux deux conditions suivantes :

1) L'appareil ne doit pas produire de brouillage;

2) L'appareil doit accepter tout brouillage radioélectrique subi, même si le brouillage est susceptible d'en compromettre le fonctionnement.

The device must not be co-located or operating in conjunction with any other antenna or transmitter.

L'appareil ne doit pas être localisé ou fonctionner avec d'autres antennes ou transmetteurs.

This device complies with IC radiation exposure limits set forth for an uncontrolled environment.

Cet appareil est conforme aux limites d'exposition aux rayonnements de la IC établies pour un incontrôlé environnement.

The device should be installed and operated with a minimum distance of 20cm between the radiator and your body.

L'appareil doit être installé et utilisé avec une distance minimale de 20 cm entre le radiateur et votre corps.

# CAUTION ON MODIFICATIONS

Any changes or modifications not expressly approved by the grantee of this device may void the authority granted by the FCC to operate this equipment. Electric and electronic equipment contains materials, components and substances that can be hazardous to your health and the environment, if the waste material (discarded electric and electronic equipment) is not handled correctly. Electric and electronic equipment is marked with the crossed-out trash can symbol, seen below. This symbol signifies that electric and electronic equipment should not be disposed of with other household waste but should be disposed of separately. All cities have established collection points, where electric and electronic equipment can either be submitted free of charge at recycling stations and other collection sites or be collected from the households. Additional information is available at the technical department of your city.



## CALIFORNIA PROP 65 WARNING

“WARNING” This product contains chemicals known to the State of California to cause birth defects or other reproductive harm. For more information on these regulations and a list of chemicals, visit the following website address:

<http://www.oehha.ca.gov/prop65.html>

# SUPPORT

We do our best to offer high quality products to our customers. If you experience any issues or problems with your product, please contact customer support as many issues can be quickly resolved.

If you have problems with your device, please consult the instructions in this manual. Please also visit us on the web at [www.naxa.com](http://www.naxa.com) to get up to the minute news, alerts, and documentation for your device. For additional assistance, please contact Naxa Technical Support.

## Naxa Technical Support

2320 East 49<sup>th</sup> St.

Vernon, CA 90058

(866) 411-6292

<http://www.naxa.com/supportcenter>

*\*This product has been manufactured and sold under the responsibility of NAXA ELECTRONICS INC.*

*VICTOR and the DOG & GRAMOPHONE logo are trademarks used under license by NAXA ELECTRONICS INC.*

*Further information at [www.victor-brand.com](http://www.victor-brand.com).*

*All other products, services, companies, trademarks, trade or product names and logos referenced herein are the property of their respective owners.*