

TEST REPORT

FCC Test for N20-HRDU_2500_FB_TDD

APPLICANT
SOLiD, Inc.

REPORT NO.
HCT-RF-2107-FC015

DATE OF ISSUE
July 9, 2021

Tested by
Kyung Soo Kang



Technical Manager
Jong Seok Lee



HCT CO., LTD.
Bongjai Huh
BongJai Huh / CEO

HCT Co., Ltd.

74, Seoicheon-ro 578beon-gil, Majang-myeon, Icheon-si, Gyeonggi-do, 17383 KOREA
Tel. +82 31 634 6300 Fax. +82 31 645 6401

TEST REPORT

FCC Test for
N20-HRDU_2500
_FB_TDD

REPORT NO.
HCT-RF-2107-FC015

DATE OF ISSUE
July 09, 2021

Additional Model
-

Applicant **SOLiD, Inc.**
10, 9th Floor, SOLiD Space, Pangyoyeok-ro 220, Bundang-gu, Seongnam-si,
Gyeonggi-do, 463-400, South Korea

Eut Type DAS
Model Name N20-HRDU_2500_FB_TDD

FCC ID W6UNH25FBTDD

Output Power 43 dBm

Date of Test June 25, 2021~ July 07, 2021

FCC Rule Parts: CFR 47 Part 2, Part 27

The result shown in this test report refer only to the sample(s) tested unless otherwise stated.
This test results were applied only to the test methods required by the standard.

REVISION HISTORY

The revision history for this test report is shown in table.

Revision No.	Date of Issue	Description
0	July 09, 2021	Initial Release

The measurements shown in this report were made in accordance with the procedures indicated, and the emissions from this equipment were found to be within the limits applicable. I assume full responsibility for the accuracy and completeness of these measurements, and for the qualifications of all persons taking them. It is further stated that upon the basis of the measurements made, the equipment tested is capable of operation in accordance with the requirements of the FCC Rules under normal use and maintenance.

If this report is required to confirmation of authenticity, please contact to www.hct.co.kr

CONTENTS

1. GENERAL INFORMATION	5
1.1. APPLICANT INFORMATION	5
1.2. PRODUCT INFORMATION	5
1.3. TEST INFORMATION	5
2. FACILITIES AND ACCREDITATIONS	6
2.1. FACILITIES	6
2.2. EQUIPMENT	6
3. TEST SPECIFICATIONS	7
3.1. STANDARDS	7
3.2. ADDITIONAL DESCRIPTIONS ABOUT TEST	8
3.3. MEASUREMENT UNCERTAINTY	10
3.4. STANDARDS ENVIRONMENTAL TEST CONDITIONS	10
3.5. TEST DIAGRAMS	11
4. TEST EQUIPMENTS	12
5. TEST RESULT	13
5.1. AGC THRESHOLD	13
5.2. OUT-OF-BAND REJECTION	15
5.3. INPUT-VERSUS-OUTPUT SIGNAL COMPARISON	17
5.4. INPUT/OUTPUT POWER AND AMPLIFIER/BOOSTER GAIN	33
5.5. OUT-OF-BAND/OUT-OF-BLOCK EMISSIONS AND SPURIOUS EMISSIONS	40
5.6. RADIATED SPURIOUS EMISSIONS	70
6. Annex A_EUT AND TEST SETUP PHOTO	73

1. GENERAL INFORMATION

1.1. APPLICANT INFORMATION

Company Name	SOLiD, Inc.
Company Address	10, 9th Floor, SOLiD Space, Pangyoyeok-ro 220, Bundang-gu, Seongnam-si, Gyeonggi-do, 463-400, South Korea

1.2. PRODUCT INFORMATION

EUT Type	DAS	
EUT Serial Number	R25H0000001	
Power Supply	AC 110-220V, 50/60Hz DC -48V	
Frequency Range	Band Name	Downlink (MHz)
	BRS/EBS	2 496 ~ 2 690
Tx Output Power	43 dBm	
Antenna Peak Gain	17 dBi	

1.3. TEST INFORMATION

FCC Rule Parts	CFR 47 Part 2, Part 27
Measurement Standards	KDB 935210 D05 v01r04, KDB 971168 D01 v03r01, ANSI C63.26-2015
Test Location	HCT CO., LTD. 74, Seoicheon-ro 578beon-gil, Majang-myeon, Icheon-si, Gyeonggi-do, 17383, Rep. of KOREA

2. FACILITIES AND ACCREDITATIONS

2.1. FACILITIES

The SAC(Semi-Anechoic Chamber) and conducted measurement facility used to collect the radiated data are located at the 74, Seoicheon-ro 578beon-gil, Majang-myeon, Icheon-si, Gyeonggi-do, 17383, Rep. of KOREA.

The site is constructed in conformance with the requirements of ANSI C63.4 (Version: 2014) and CISPR Publication 22.

Detailed description of test facility was submitted to the Commission and accepted dated April 02, 2018 (Registration Number: KR0032).

2.2. EQUIPMENT

Radiated emissions are measured with one or more of the following types of linearly polarized antennas: tuned dipole, bi-conical, log periodic, bi-log, and/or ridged waveguide, horn. Spectrum analyzers with pre-selectors and quasi-peak detectors are used to perform radiated measurements.

Calibrated wideband preamplifiers, coaxial cables, and coaxial attenuators are also used for making measurements.

All receiving equipment conforms to CISPR Publication 16-1, "Radio Interference Measuring Apparatus and Measurement Methods."

3. TEST SPECIFICATIONS

3.1. STANDARDS

The following tests were conducted on a sample of the equipment for the purpose of demonstrating compliance with FCC Part 2 and Par 27.

Description	Reference	Results
AGC threshold	KDB 935210 D05 v01r04 3.2	Compliant
Out-of-band rejection	KDB 935210 D05 v01r04 3.3	Compliant
Input-versus-output signal comparison	§ 2.1049	Compliant
Input/output power and amplifier/booster gain	§ 2.1046, § 27.50(h)	Compliant
Out-of-band/out-of-block emissions and spurious emissions	§ 2.1051, § 27.53(m)	Compliant
Spurious emissions radiated	§ 2.1053	Compliant

3.2. ADDITIONAL DESCRIPTIONS ABOUT TEST

Except for the following cases, EUT was tested under normal operating conditions.

: Out-of-band rejection test requires maximum gain condition without AGC.

This EUT is supported power supply both of AC and DC. Test results are only attached worst cases.

The test was generally based on the method of KDB 935210 D05 v01r04 and only followed ANSI C63.26-2015 if there was no test method in KDB standard.

EUT was tested with following modulated signals provide by applicant.

Band Name	Tested signals
BRS/EBS United	LTE 20 MHz
	5G NR 20 MHz
	5G NR 40 MHz
	5G NR 60 MHz
	5G NR 80 MHz
	5G NR 100 MHz

*Simultaneous filter supporting LTE + 5G NR.

The frequency stability measurement has been omitted in accordance with section 3.7 of KDB 935210 D05 v01r04.

: It can be confirmed through input-versus-output signal comparison test that EUT does not alter the input signal.

The tests results included actual loss value for attenuator and cable combination as shown in the table below.

: Input Path

Correction factor table			
Frequency (MHz)	Factor (dB)	Frequency (MHz)	Factor (dB)
1 900	1.125	2 350	1.453
1 950	1.502	2 400	1.500
2 000	1.359	2 450	1.343
2 050	1.265	2 500	1.296
2 100	1.204	2 550	1.394
2 150	1.318	2 600	1.537
2 200	1.208	2 650	1.320
2 250	1.561	2 700	1.588
2 300	1.293	-	-

: Output Path

Correction factor table

Frequency (MHz)	Factor (dB)	Frequency (MHz)	Factor (dB)
2	29.285	30 00	33.138
10	29.383	4 000	34.055
30	29.358	5 000	35.488
50	29.423	6 000	35.825
100	29.644	7 000	36.974
200	29.970	8 000	37.731
300	30.193	9 000	38.292
400	30.391	10 000	39.318
500	30.546	11 000	38.223
600	30.693	12 000	38.604
700	30.850	13 000	38.088
800	30.961	14 000	39.527
900	31.104	15 000	39.790
1 000	31.234	16 000	40.284
1 100	31.376	17 000	39.296
1 200	31.533	18 000	39.680
1 300	31.615	19 000	40.452
1 400	31.731	20 000	41.104
1 500	31.793	21 000	43.448
1 600	31.918	22 000	42.703
1 700	31.977	23 000	43.767
1 800	32.059	24 000	43.265
1 900	32.158	25 000	44.990
2 000	32.252	26 000	45.921
2 100	32.357	26 500	41.956
2 200	32.417	-	-
2 300	32.519	-	-
2 400	32.643	-	-
2 500	32.743	-	-
2 600	32.853	-	-
2 700	32.984	-	-

3.3. MEASUREMENT UNCERTAINTY

Description	Reference	Results
AGC threshold	-	±0.87 dB
Out-of-band rejection	-	±0.58 MHz
Input-versus-output signal comparison	OBW > 5 MHz	±0.58 MHz
Input/output power and amplifier/booster gain	-	±0.87 dB
Out-of-band/out-of-block emissions and spurious emissions	-	±1.08 dB
Spurious emissions radiated	f ≤ 1 GHz	±4.80 dB
	f > 1 GHz	±6.07 dB

* Coverage factor $k = 2$, Confidence levels of 95 %

3.4. STANDARDS ENVIRONMENTAL TEST CONDITIONS

Temperature	+15 °C to +35 °C
Relative humidity	30 % to 60 %
Air pressure	860 mbar to 1 060 mbar

3.5. TEST DIAGRAMS

Conducted Test

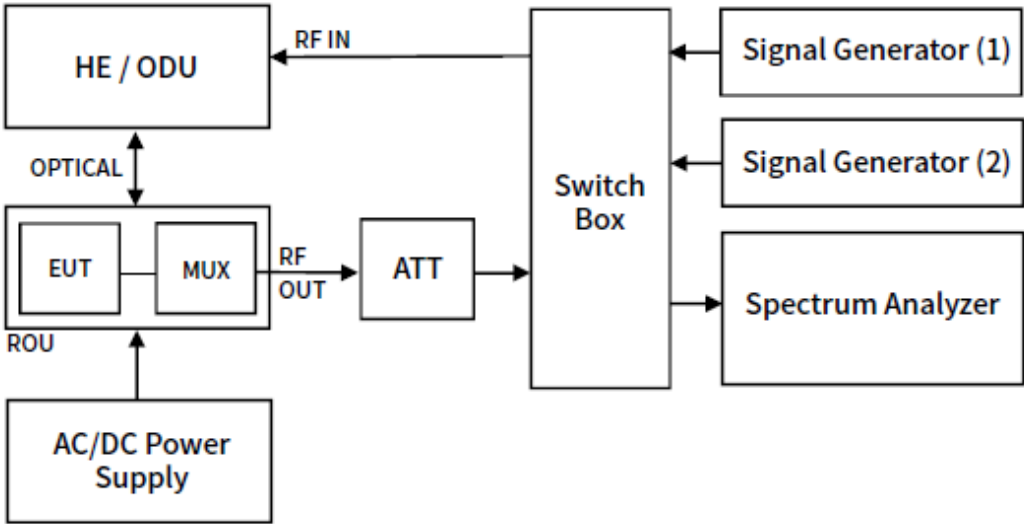

Radiated Test

30 MHz ~ 1 GHz

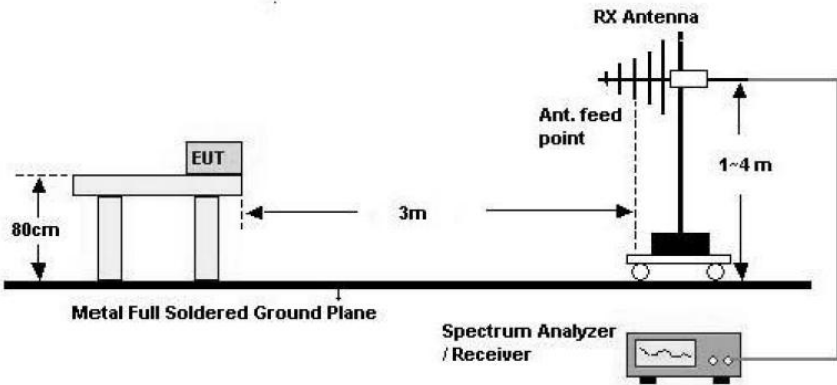

Above 1 GHz

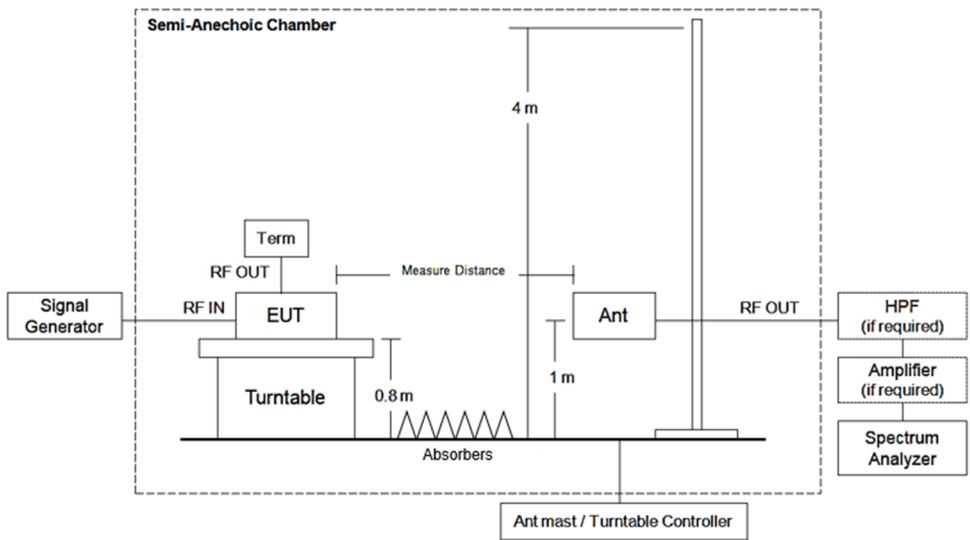

4. TEST EQUIPMENTS

Manufacturer	Model / Equipment	Calibration Date	Calibration Interval	Serial No.
Keysight	N9030B / PXA Signal Analyzer	06/02/2021	Annual	MY55480167
Agilent	N5182A / MXG Vector Signal Generator	01/08/2021	Annual	MY47070406
Agilent	N5182A / MXG Vector Signal Generator	12/02/2020	Annual	MY46240807
Weinschel Associates	WA93-30-33 / 30 dB Attenuator	03/30/2021	Annual	0202
KEITHLEY	S46 / Switch	N/A	N/A	1088024
Innco systems	CO3000 / Controller(Antenna mast & Turn Table)	N/A	N/A	CO3000/1251/ 48920320/P
Innco systems	MA4640/800-XP-ET / Antenna Position Tower	N/A	N/A	N/A
Innco systems	DS2000-S / Turn Table	N/A	N/A	N/A
Ets	Turn Table	N/A	N/A	N/A
TNM system	FBSM-01B / Amp & Filter Bank Switch Controller	N/A	N/A	TM20090002
Schwarzbeck	FMZB 1513 / Loop Antenna	03/19/2020	Biennial	1513-333
Schwarzbeck	VULB 9168 / Hybrid Antenna	08/02/2019	Biennial	01039
Schwarzbeck	BBHA 9120D / Horn Antenna	05/19/2020	Biennial	02296
Schwarzbeck	BBHA9170 / Horn Antenna(15 GHz ~ 40 GHz)	10/13/2020	Biennial	BBHA9170342
Rohde & Schwarz	FSP40 / Spectrum Analyzer	05/27/2021	Annual	100843
CERNEC	CBL18265035 / Power Amplifier	12/04/2020	Annual	22966
CERNEC	CBL26405040 / Power Amplifier	03/23/2021	Annual	25956
TNM system	FBSR-04C / HPF(3~18GHz) + LNA1(1~18GHz)	09/23/2020	Annual	N/A
LTC Microwave	LLAU1183540Q / Low Noise Amplifier	09/23/2020	Annual	100
Wainwright Instruments	WHKX12-2805-3000-18000-40SS / High Pass Filter	09/23/2020	Annual	45

Note:

1. Equipment listed above that calibrated during the testing period was set for test after the calibration.
2. Equipment listed above that has a calibration due date during the testing period, the testing is completed before equipment expiration date.

5. TEST RESULT

5.1. AGC THRESHOLD

Test Requirement:

KDB 935210 D05 v01r04

Testing at and above the AGC threshold is required.

Test Procedures:

Measurements were in accordance with the test methods section 3.2 of KDB 935210 D05 v01r04.

In the case of fiber-optic distribution systems, the RF input port of the equipment under test (EUT) refers to the RF input of the supporting equipment RF to optical convertor; see also descriptions and diagrams for typical DAS booster systems in KDB Publication 935210 D02

Devices intended to be directly connected to an RF source (donor port) only need to be evaluated for any over-the-air transmit paths.

- a) Connect a signal generator to the input of the EUT.
- b) Connect a spectrum analyzer or power meter to the output of the EUT using appropriate attenuation as necessary.
- c) The signal generator should initially be configured to produce either of the required test signals.
- d) Set the signal generator frequency to the center frequency of the EUT operating band.
- e) While monitoring the output power of the EUT, measured using the methods of ANSI C63.26-2015 subclause 5.2.4.4.1, increase the input level until a 1 dB increase in the input signal power no longer causes a 1 dB increase in the output signal power.
- f) Record this level as the AGC threshold level.
- g) Repeat the procedure with the remaining test signal.

Output power measurement in subclause 5.2.4.4.1 of ANSI C63.26

- a) Set span to $2 \times$ to $3 \times$ the OBW.
- b) Set RBW = 1% to 5% of the OBW.
- c) Set VBW $\geq 3 \times$ RBW.
- d) Set number of measurement points in sweep $\geq 2 \times$ span / RBW.
- e) Sweep time: auto-couple
- f) Detector = power averaging (rms).
- g) If the EUT can be configured to transmit continuously, then set the trigger to free run.
- h) Omit
- i) Trace average at least 100 traces in power averaging (rms) mode if sweep is set to auto-couple. To accurately determine the average power over multiple symbols, it can be necessary to increase the number of traces to be

averaged above 100 or, if using a manually configured sweep time, increase the sweep time.

- j) Compute the power by integrating the spectrum across the OBW of the signal using the instrument’s band or channel power measurement function, with the band/channel limits set equal to the OBW band edges. If the instrument does not have a band or channel power function, then sum the spectrum levels (in linear power units) at intervals equal to the RBW extending across the entire OBW of the spectrum.

Test Results:

Test Band	Link	Signal	Center Frequency (MHz)	AGC Threshold Level (dBm)	Output Level (dBm)
BRS/EBS United	Downlink	LTE 20MHz	2593.00	-20	43.26
		5G NR 20 MHz	2593.00	-20	43.24
		5G NR 40 MHz	2593.00	-20	43.23
		5G NR 60 MHz	2593.00	-20	43.20
		5G NR 80 MHz	2593.00	-20	43.29
		5G NR 100 MHz	2593.00	-20	43.38

5.2. OUT-OF-BAND REJECTION

Test Requirement:

KDB 935210 D05 v01r04

Out-of-band rejection required.

Test Procedures:

Measurements were in accordance with the test methods section 3.3 of KDB 935210 D05 v01r04.

A signal booster shall reject amplification of other signals outside of its passband. Adjust the internal gain control of the EUT (if so equipped) to the maximum gain for which equipment certification is sought.

- a) Connect a signal generator to the input of the EUT.
- b) Configure a swept CW signal with the following parameters:
 - 1) Frequency range = $\pm 250\%$ of the passband, for each applicable CMRS band.
 - 2) Level = a sufficient level to affirm that the out-of-band rejection is > 20 dB above the noise floor and will not engage the AGC during the entire sweep.
 - 3) Dwell time = approximately 10 ms.
 - 4) Number of points = $\text{SPAN}/(\text{RBW}/2)$.
- c) Connect a spectrum analyzer to the output of the EUT using appropriate attenuation.
- d) Set the span of the spectrum analyzer to the same as the frequency range of the signal generator.
- e) Set the resolution bandwidth (RBW) of the spectrum analyzer to be 1 % to 5 % of the EUT passband, and the video bandwidth (VBW) shall be set to $\geq 3 \times \text{RBW}$.
- f) Set the detector to Peak Max-Hold and wait for the spectrum analyzer's spectral display to fill.
- g) Place a marker to the peak of the frequency response and record this frequency as f_0 .
- h) Place two markers, one at the lowest and the other at the highest frequency of the envelope of the spectral display, such that each marker is at or slightly below the -20 dB down amplitude, to determine the 20 dB bandwidth.
- i) Capture the frequency response of the EUT.
- j) Repeat for all frequency bands applicable for use by the EUT.

Test Results:

BRS/EBS United (2 496 MHz ~ 2 690 MHz) / Downlink

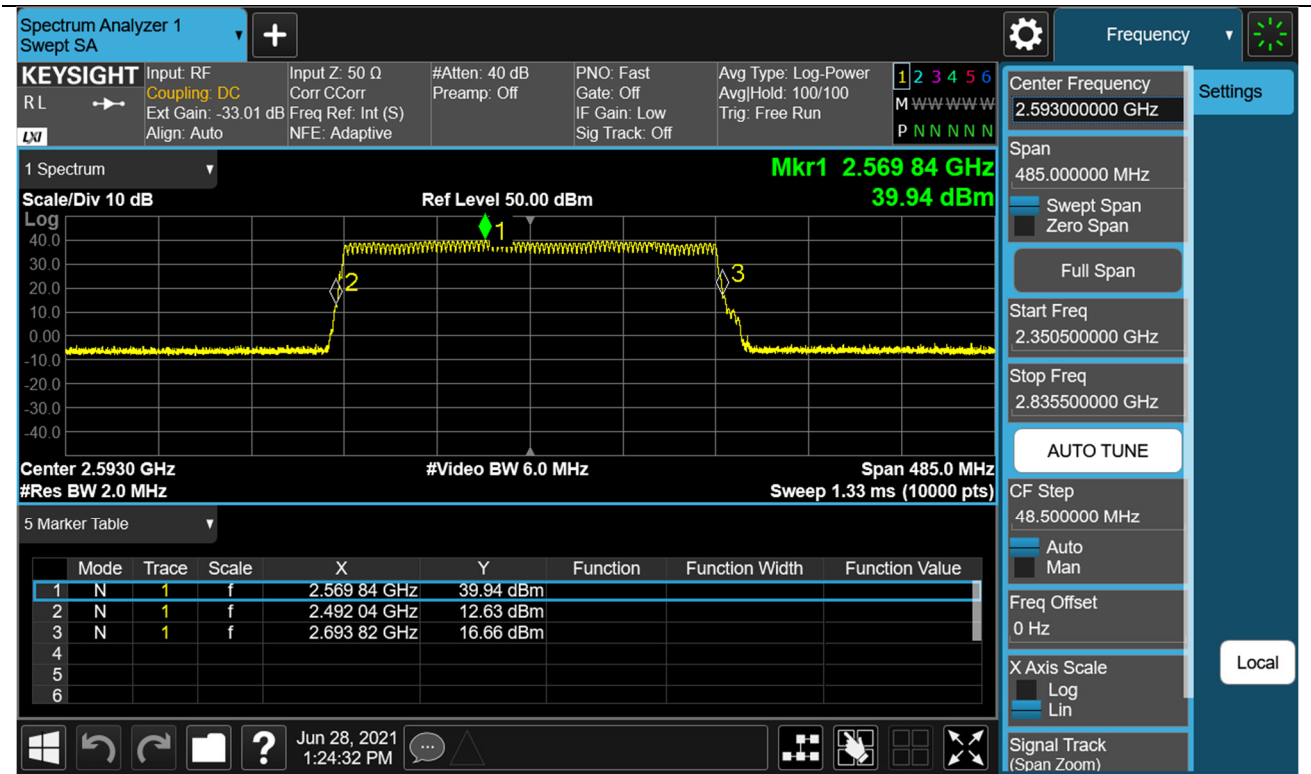

5.3. INPUT-VERSUS-OUTPUT SIGNAL COMPARISON

Test Requirement:

§ 2.1049 Measurements required: Occupied bandwidth.

The occupied bandwidth, that is the frequency bandwidth such that, below its lower and above its upper frequency limits, the mean powers radiated are each equal to 0.5 percent of the total mean power radiated by a given emission shall be measured under the specified conditions of § 2.1049 (a) through (i) as applicable.

Test Procedures:

Measurements were in accordance with the test methods section 3.4 of KDB 935210 D05 v01r04.

A 26 dB bandwidth measurement shall be performed on the input signal and the output signal; alternatively, the 99% OBW can be measured and used. See KDB Publication 971168 [R8] for more information on measuring OBW.

- a) Connect a signal generator to the input of the EUT.
- b) Configure the signal generator to transmit the AWGN signal.
- c) Configure the signal amplitude to be just below the AGC threshold level (see 3.2), but not more than 0.5 dB below.
- d) Connect a spectrum analyzer to the output of the EUT using appropriate attenuation.
- e) Set the spectrum analyzer center frequency to the center frequency of the operational band under test. The span range of the spectrum analyzer shall be between 2 times to 5 times the emission bandwidth (EBW) or alternatively, the OBW.
- f) The nominal RBW shall be in the range of 1 % to 5 % of the anticipated OBW, and the VBW shall be $\geq 3 \times$ RBW.
- g) Set the reference level of the instrument as required to preclude the signal from exceeding the maximum spectrum analyzer input mixer level for linear operation. In general, the peak of the spectral envelope must be more than $[10 \log (\text{OBW} / \text{RBW})]$ below the reference level. Steps f) and g) may require iteration to enable adjustments within the specified tolerances.
- h) The noise floor of the spectrum analyzer at the selected RBW shall be at least 36 dB below the reference level.
- i) Set spectrum analyzer detection function to positive peak.
- j) Set the trace mode to max hold.
- k) Determine the reference value: Allow the trace to stabilize. Set the spectrum analyzer marker to the highest amplitude level of the displayed trace (this is the reference value) and record the associated frequency.
- l) Place two markers, one at the lowest and the other at the highest frequency of the envelope of the spectral display, such that each marker is at or slightly below the -26 dB down amplitude. The 26 dB EBW (alternatively OBW) is the positive frequency difference between the two markers. If the spectral envelope crosses the -26 dB down amplitude at multiple points, the lowest or highest frequency shall be selected as the frequencies that are the furthest removed from the center frequency at which the spectral envelope crosses the -26 dB down amplitude point.
- m) Repeat steps e) to l) with the input signal connected directly to the spectrum analyzer (i.e., input signal

measurement).

- n) Compare the spectral plot of the input signal (determined from step m) to the output signal (determined from step l) to affirm that they are similar (in passband and rolloff characteristic features and relative spectral locations), and include plot(s) and descriptions in test report.
- o) Repeat the procedure [steps e) to n)] with the input signal amplitude set to 3 dB above the AGC threshold.
- p) Repeat steps e) to o) with the signal generator set to the narrowband signal.
- q) Repeat steps e) to p) for all frequency bands authorized for use by the EUT.

Test Results:

Tabular data of Output Occupied Bandwidth

Test Band	Link	Signal	Center Frequency (MHz)	99 % OBW (MHz)	26 dB OBW (MHz)
BRS/EBS United	Downlink	LTE 20MHz	2593.00	17.920	19.646
		5G NR 20 MHz	2593.00	18.267	19.442
		5G NR 40 MHz	2593.00	37.955	39.962
		5G NR 60 MHz	2593.00	58.126	60.993
		5G NR 80 MHz	2593.00	77.908	81.547
		5G NR 100 MHz	2593.00	97.633	102.396

Tabular data of Input Occupied Bandwidth

Test Band	Link	Signal	Center Frequency (MHz)	99 % OBW (MHz)	26 dB OBW (MHz)
BRS/EBS United	Downlink	LTE 20MHz	2593.00	17.922	19.433
		5G NR 20 MHz	2593.00	18.262	19.470
		5G NR 40 MHz	2593.00	37.938	39.920
		5G NR 60 MHz	2593.00	57.985	60.959
		5G NR 80 MHz	2593.00	77.563	81.363
		5G NR 100 MHz	2593.00	97.395	102.339

Tabular data of 3 dB above the AGC threshold Output Occupied Bandwidth

Test Band	Link	Signal	Center Frequency (MHz)	99 % OBW (MHz)	26 dB OBW (MHz)
BRS/EBS United	Downlink	LTE 20MHz	2593.00	17.978	20.055
		5G NR 20 MHz	2593.00	18.233	19.446
		5G NR 40 MHz	2593.00	37.996	39.915
		5G NR 60 MHz	2593.00	58.054	60.977
		5G NR 80 MHz	2593.00	77.761	81.646
		5G NR 100 MHz	2593.00	97.443	102.422

Tabular data of 3 dB above the AGC threshold Input Occupied Bandwidth

Test Band	Link	Signal	Center Frequency (MHz)	99 % OBW (MHz)	26 dB OBW (MHz)
BRS/EBS United	Downlink	LTE 20MHz	2593.00	17.920	19.845
		5G NR 20 MHz	2593.00	18.247	19.369
		5G NR 40 MHz	2593.00	37.937	39.935
		5G NR 60 MHz	2593.00	58.037	60.908
		5G NR 80 MHz	2593.00	77.630	81.586
		5G NR 100 MHz	2593.00	97.248	102.473

Measured Occupied Bandwidth Comparison

Test Band	Link	Signal	Variant of Input and output Occupied Bandwidth (%)	Variant of Input and 3 dB above the AGC threshold output Occupied Bandwidth (%)
BRS/EBS United	Downlink	LTE 20MHz	1.096	1.058
		5G NR 20 MHz	-0.144	0.398
		5G NR 40 MHz	0.105	-0.050
		5G NR 60 MHz	0.056	0.113
		5G NR 80 MHz	0.226	0.074
		5G NR 100 MHz	0.056	-0.050

* Change in input-output OBW is less than $\pm 5\%$.

Plot data of Occupied Bandwidth

Output / BRS/EBS / Downlink / LTE 20MHz

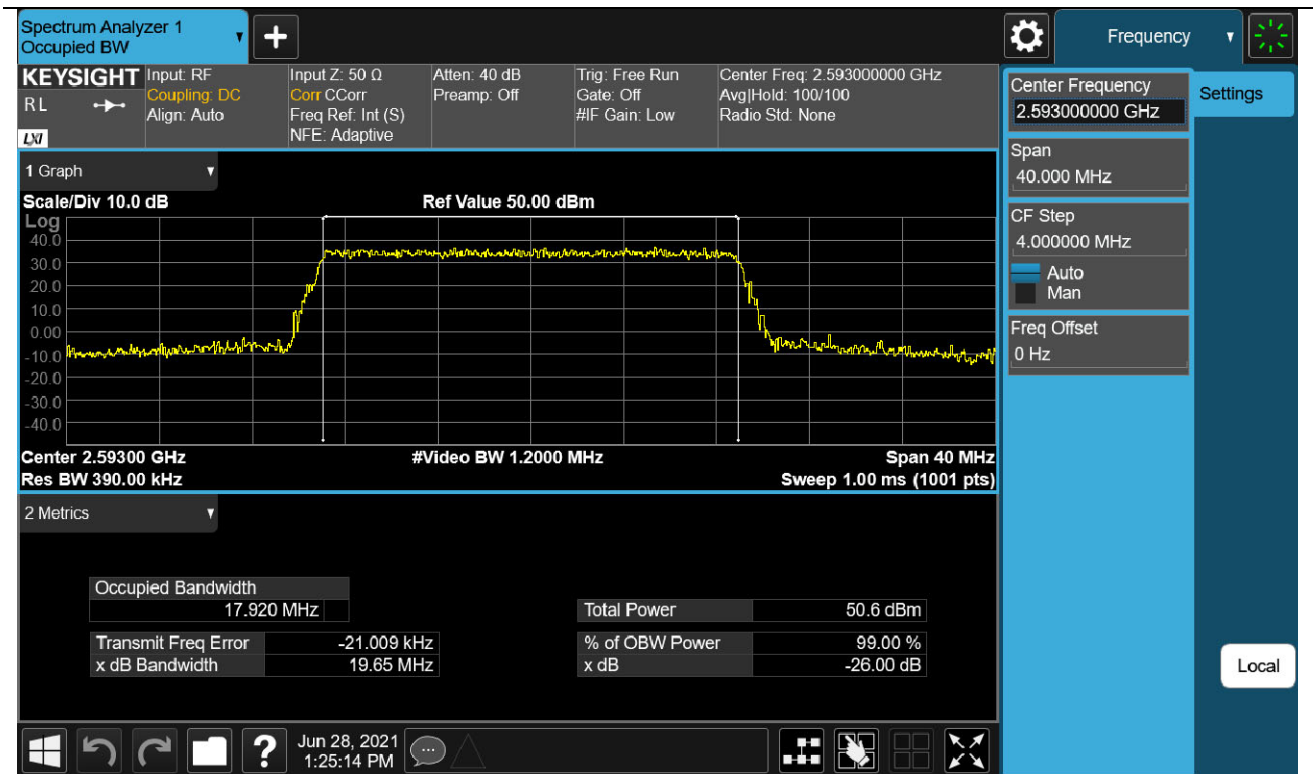

Input / BRS/EBS / Downlink / LTE 20 MHz

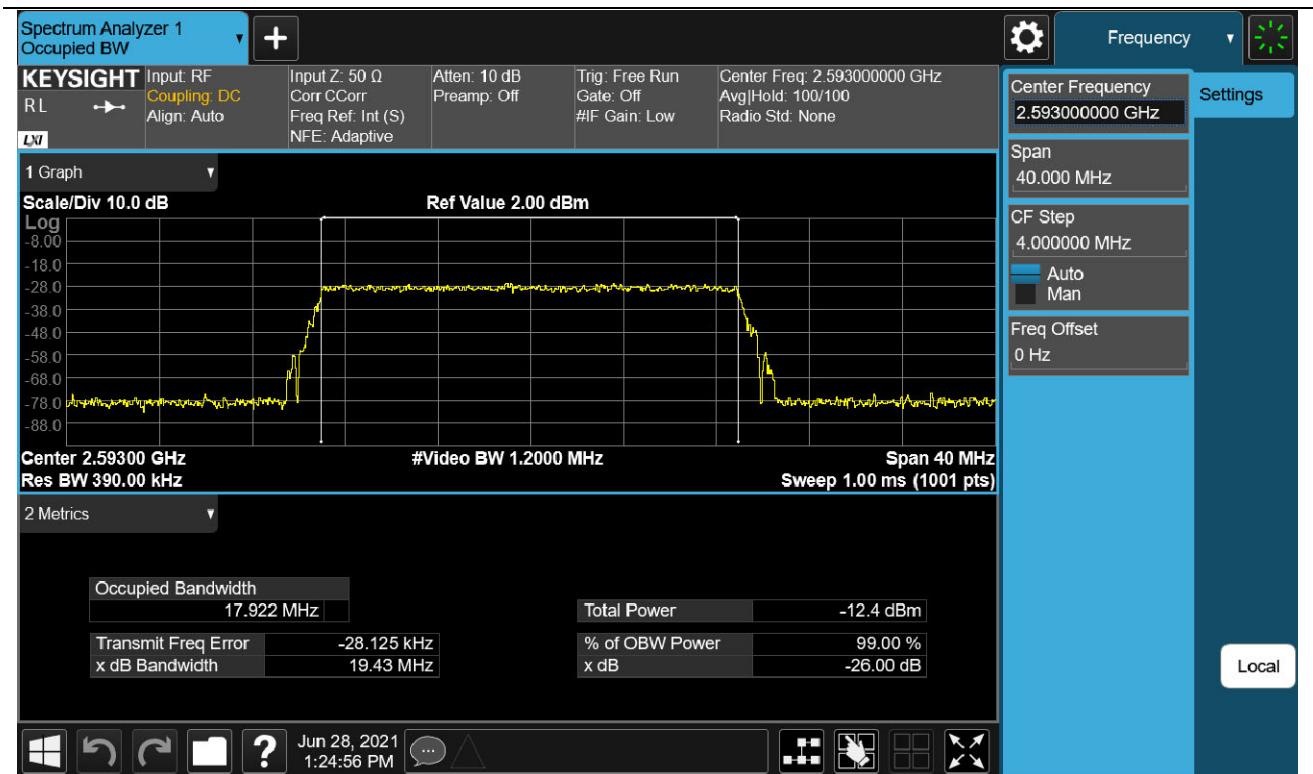

3 dB above the AGC threshold output / BRS/EBS / Downlink / LTE 20 MHz

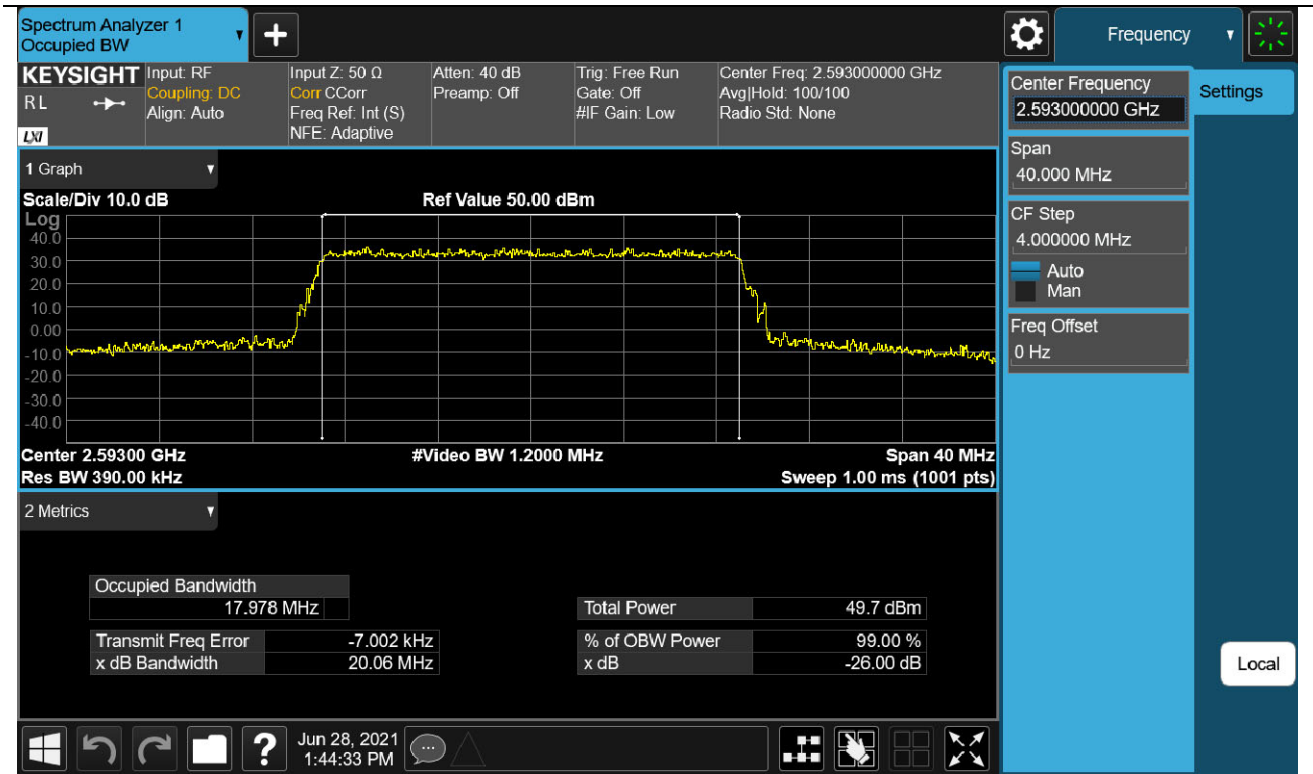

3 dB above the AGC threshold Input / BRS/EBS / Downlink / LTE 20 MHz

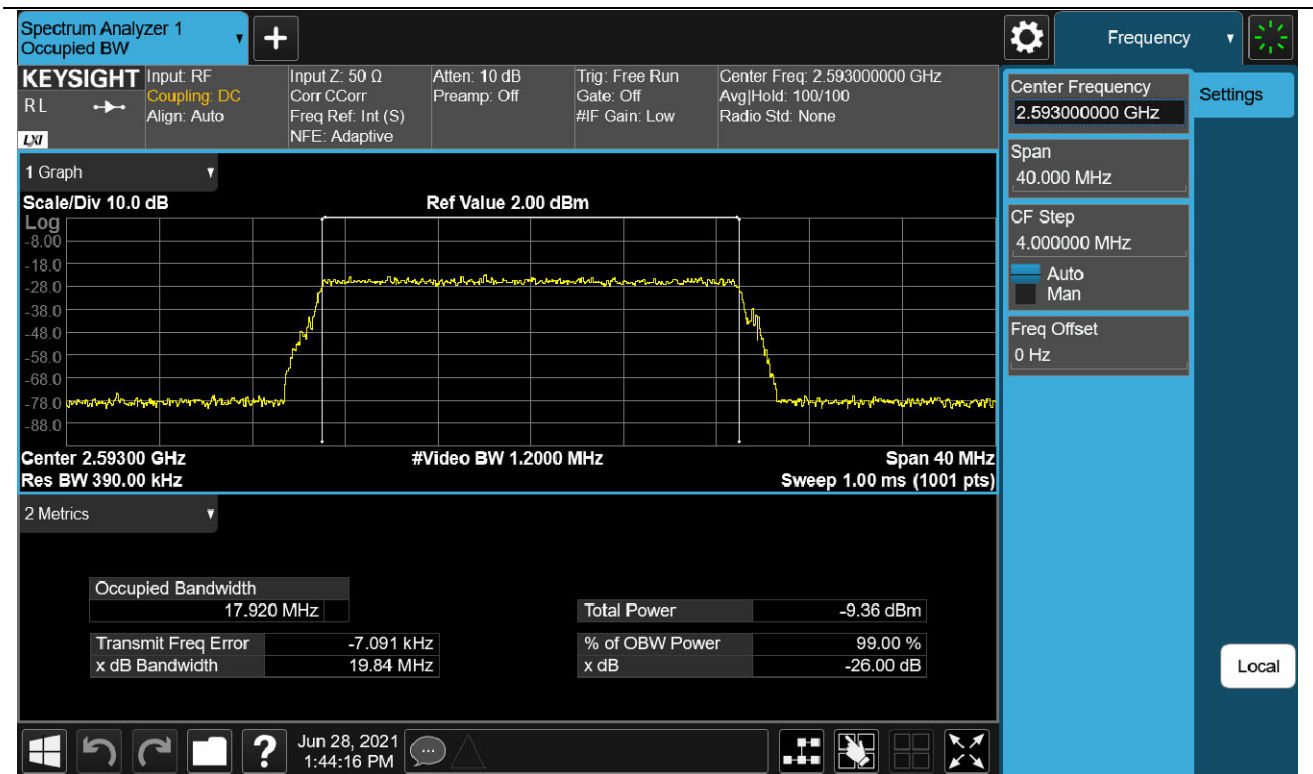

Output / BRS/EBS / Downlink / 5G NR 20 MHz

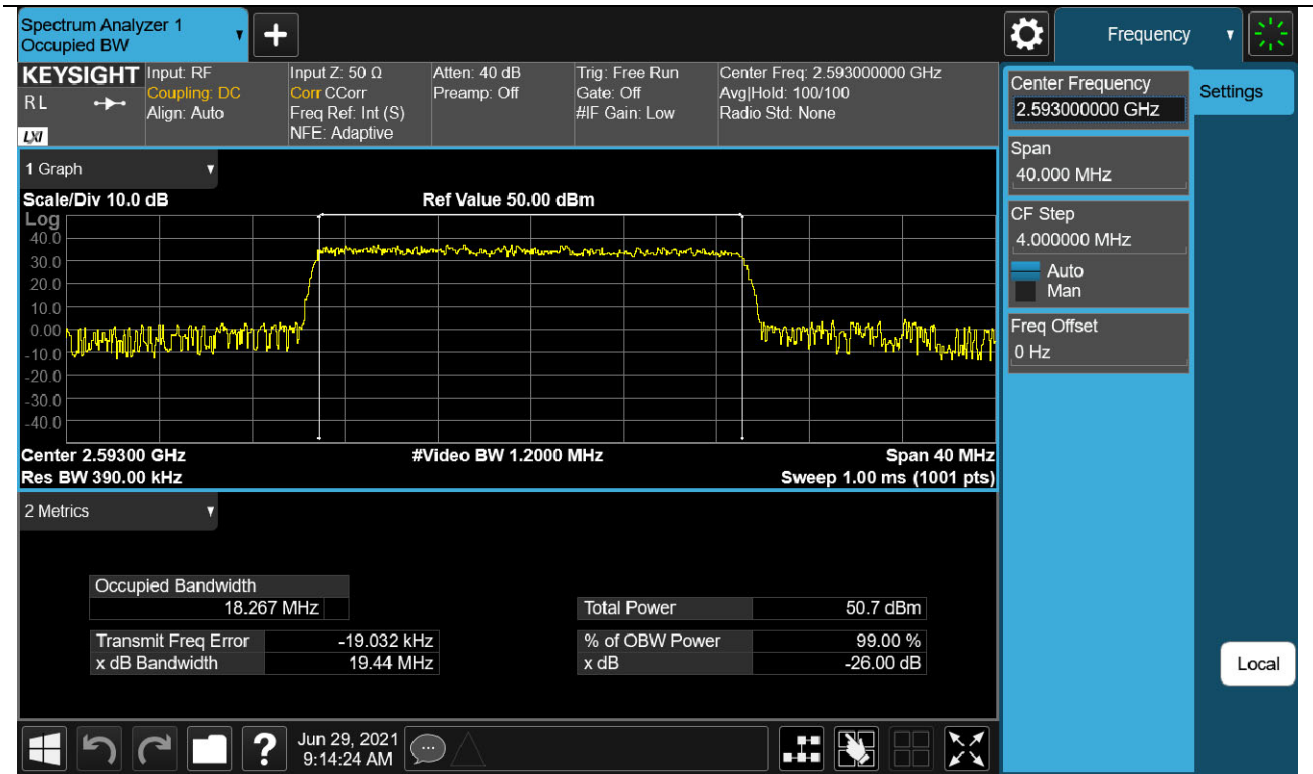

Input / BRS/EBS / Downlink / 5G NR 20 MHz

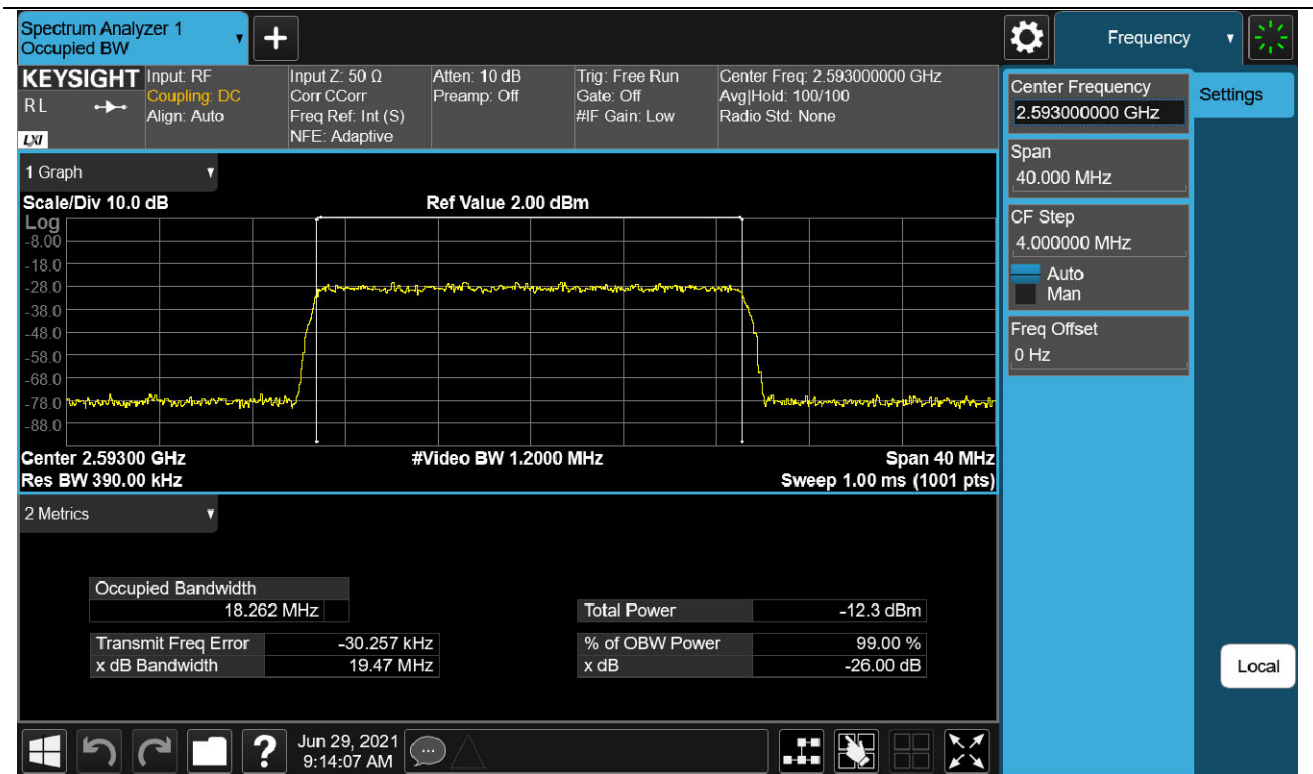

3 dB above the AGC threshold output / BRS/EBS / Downlink / 5G NR 20 MHz

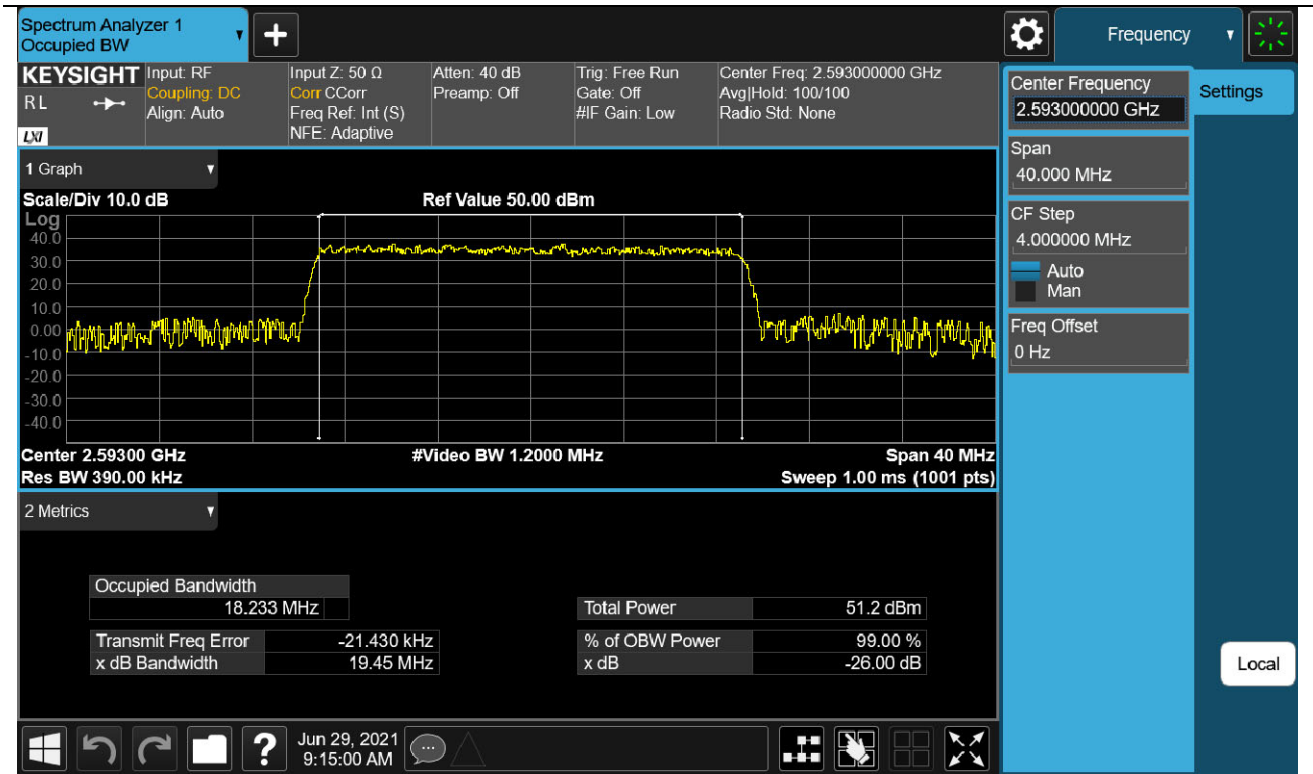

3 dB above the AGC threshold Input / BRS/EBS / Downlink / 5G NR 20 MHz

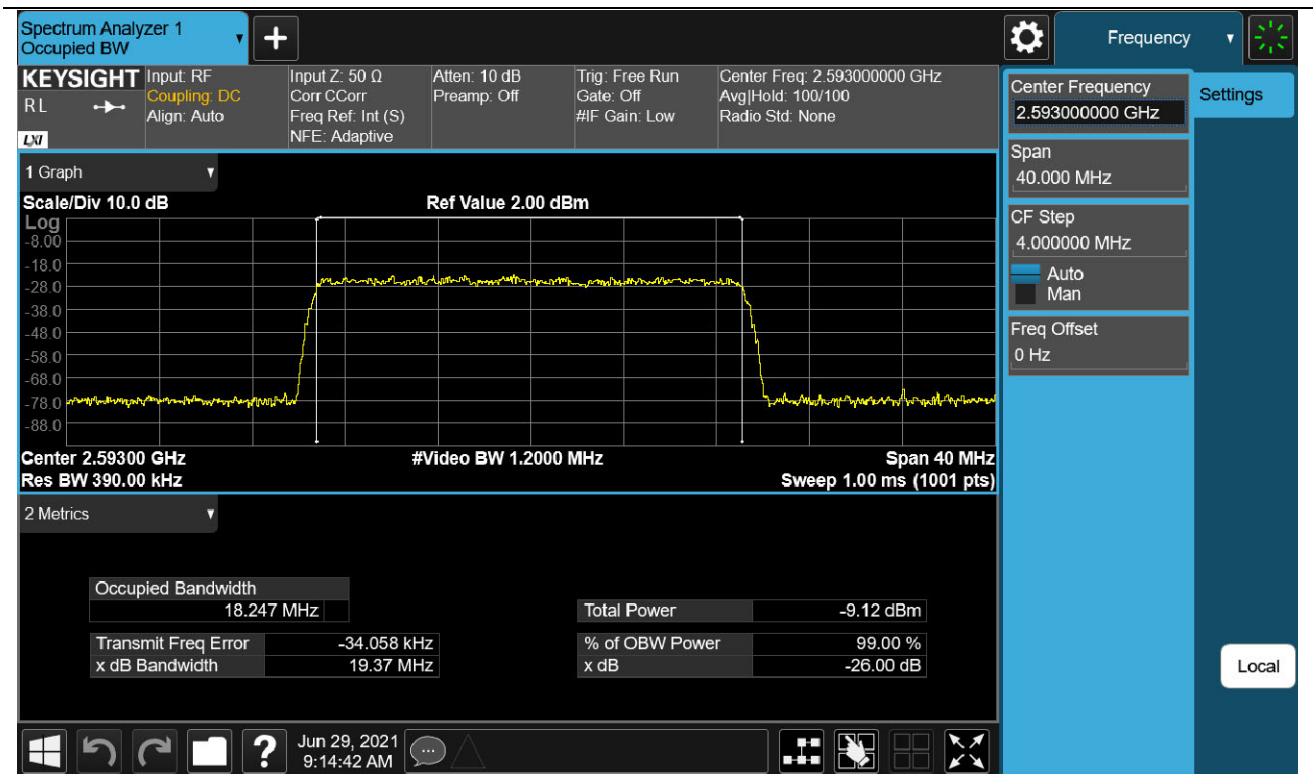

Output / BRS/EBS / Downlink / 5G NR 40 MHz

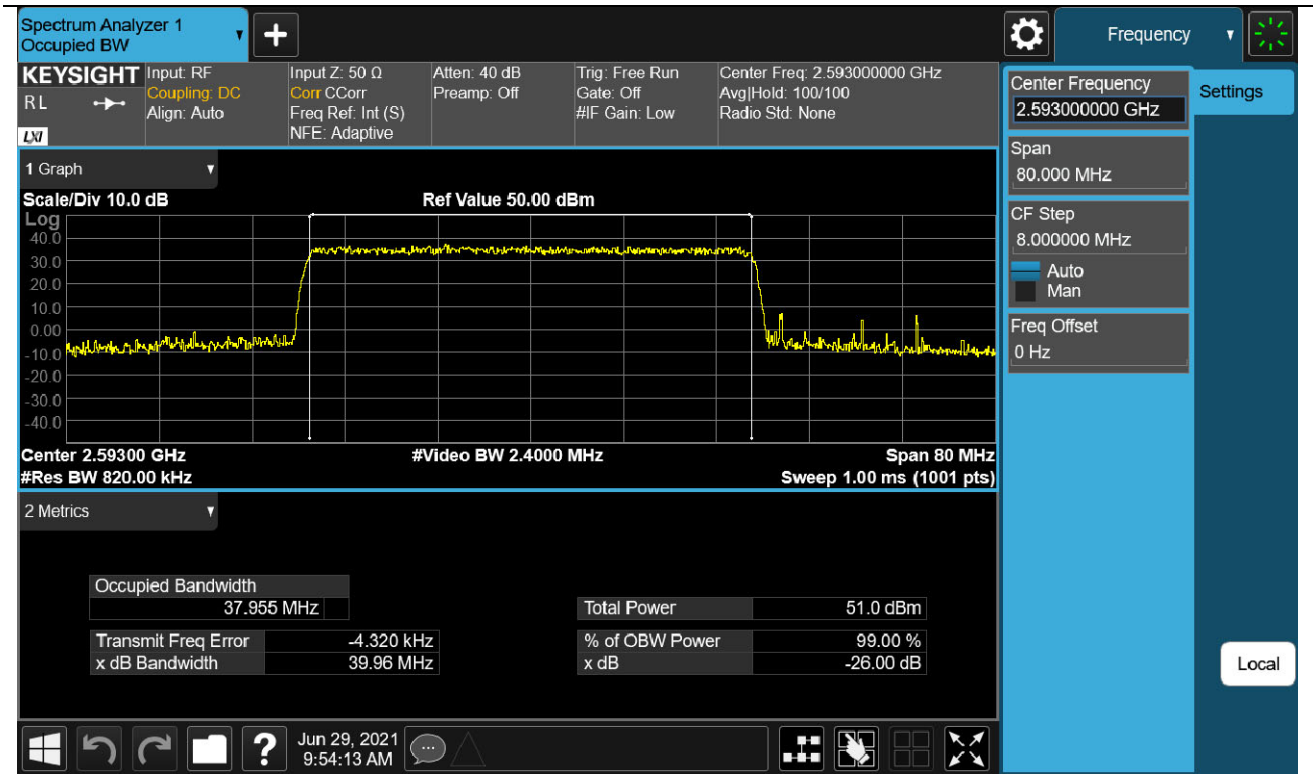

Input / BRS/EBS / Downlink / 5G NR 40 MHz

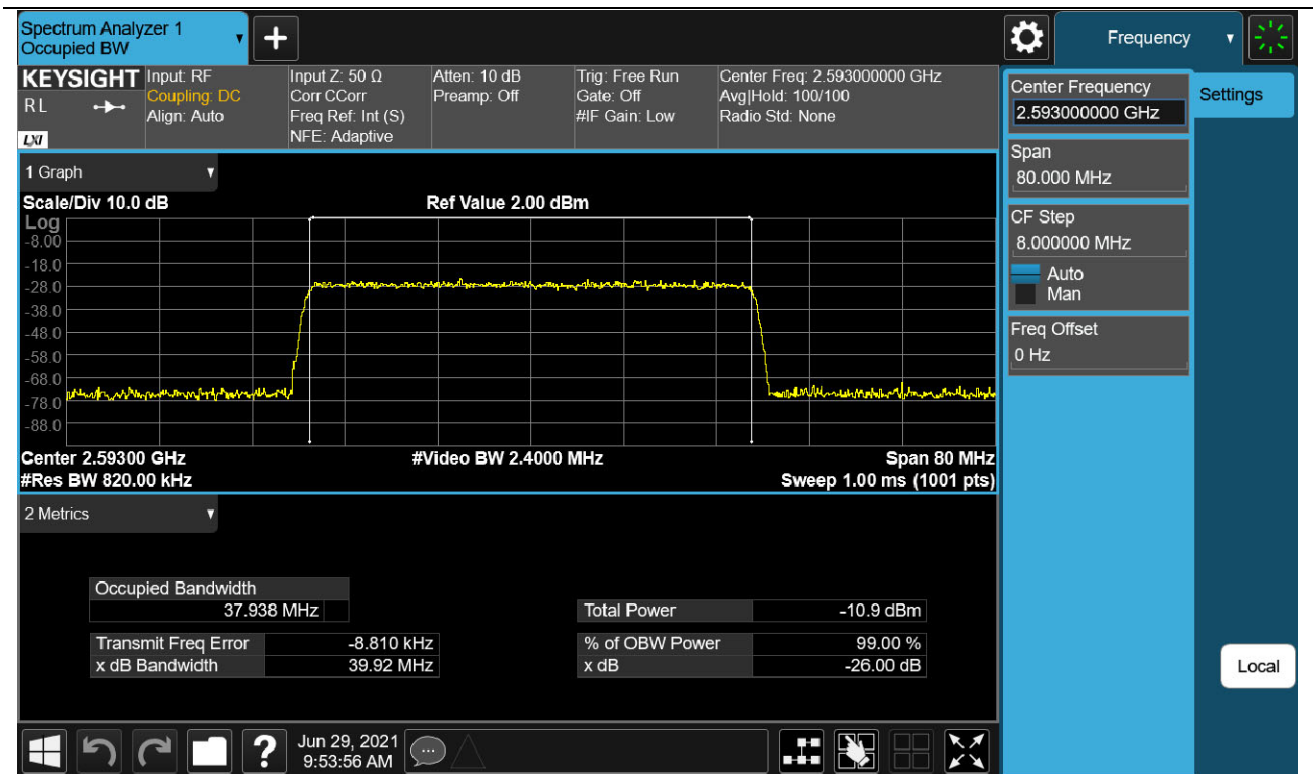

3 dB above the AGC threshold output / BRS/EBS / Downlink / 5G NR 40 MHz

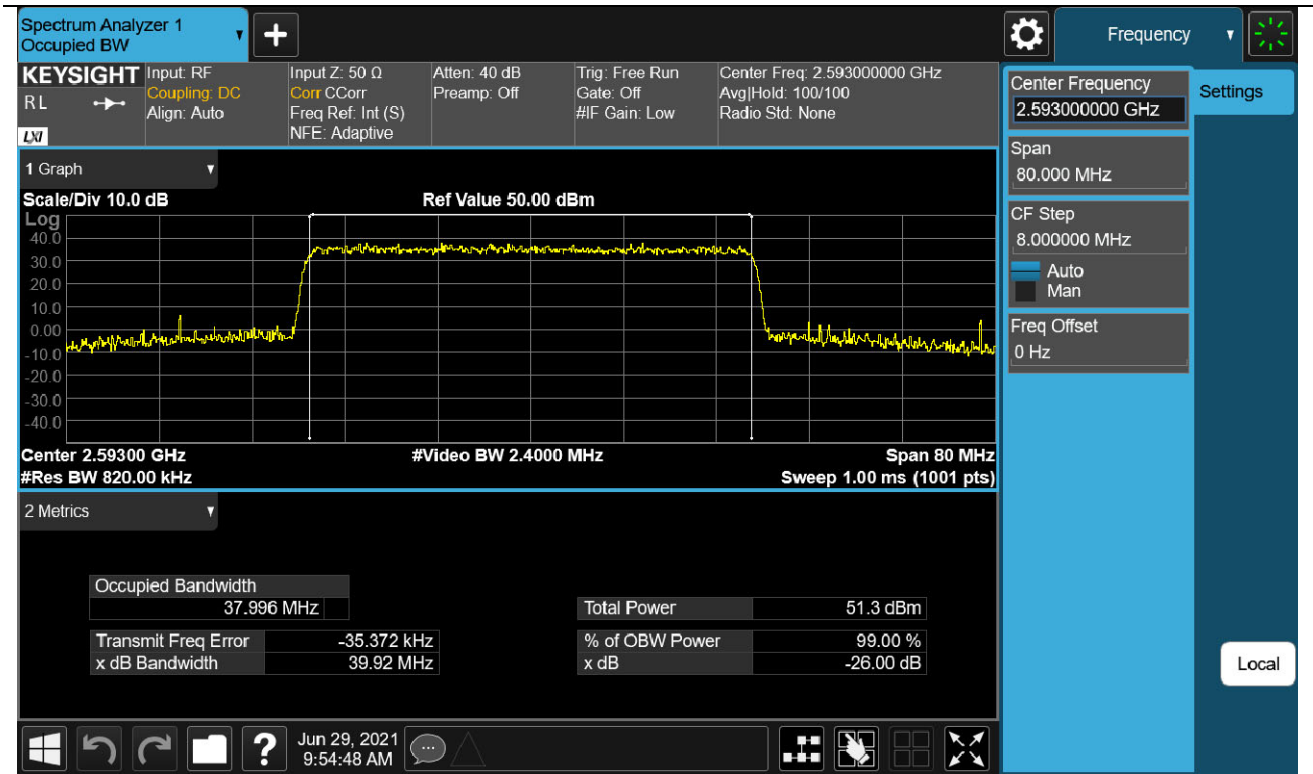

3 dB above the AGC threshold Input / BRS/EBS / Downlink / 5G NR 40 MHz

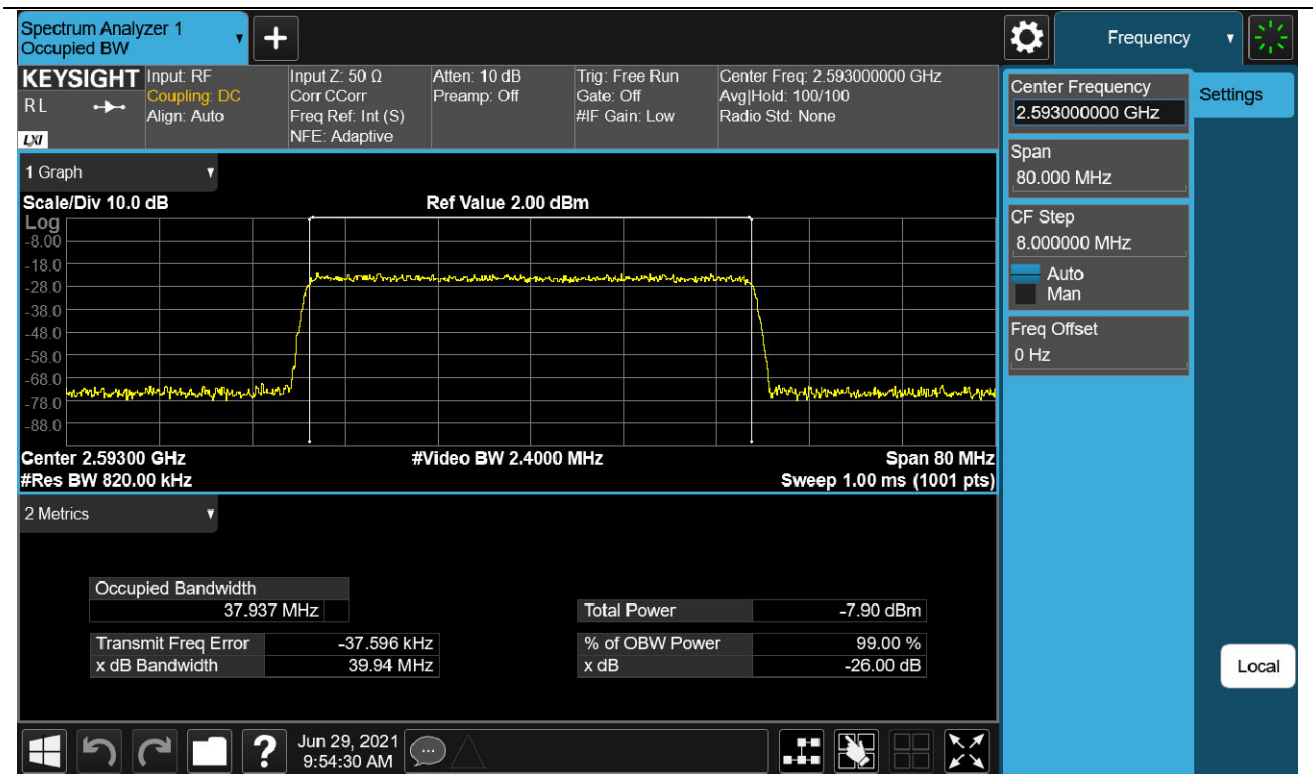

Output / BRS/EBS / Downlink / 5G NR 60 MHz

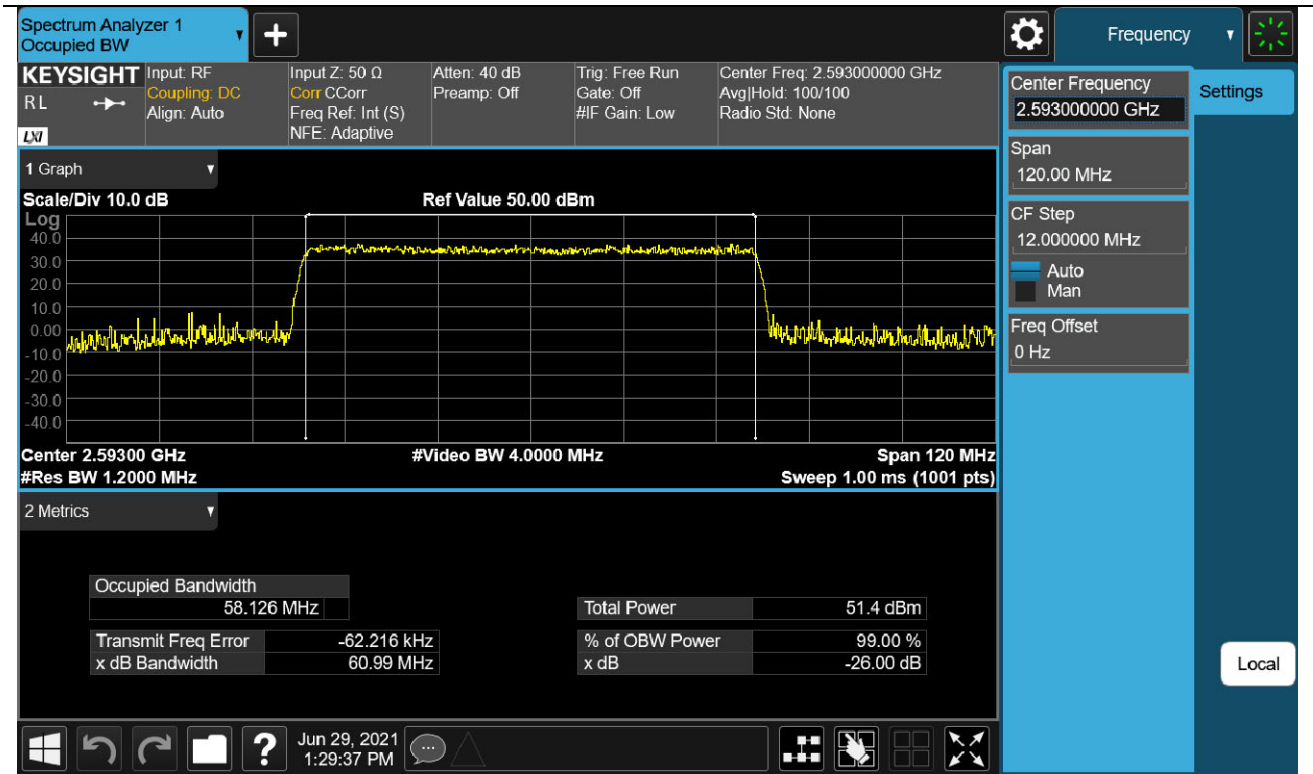

Input / BRS/EBS / Downlink / 5G NR 60 MHz

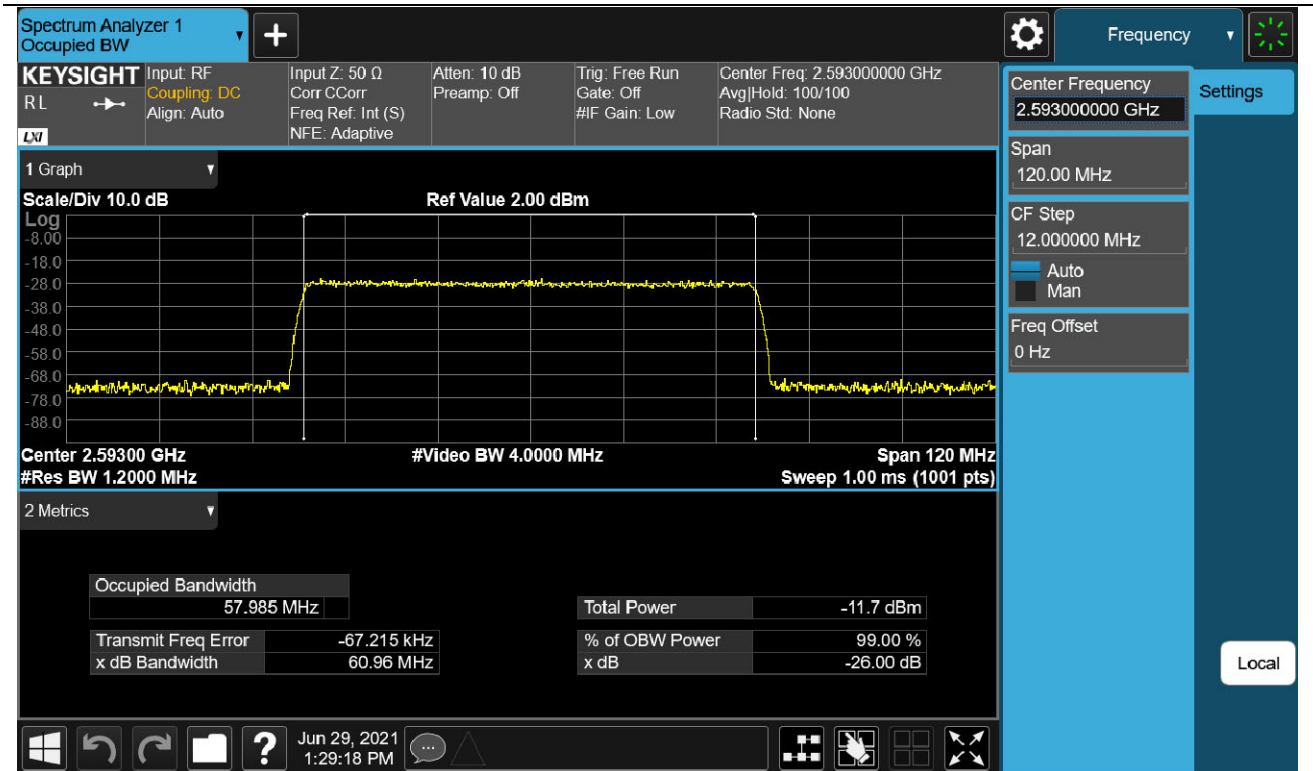

3 dB above the AGC threshold output / BRS/EBS / Downlink / 5G NR 60 MHz

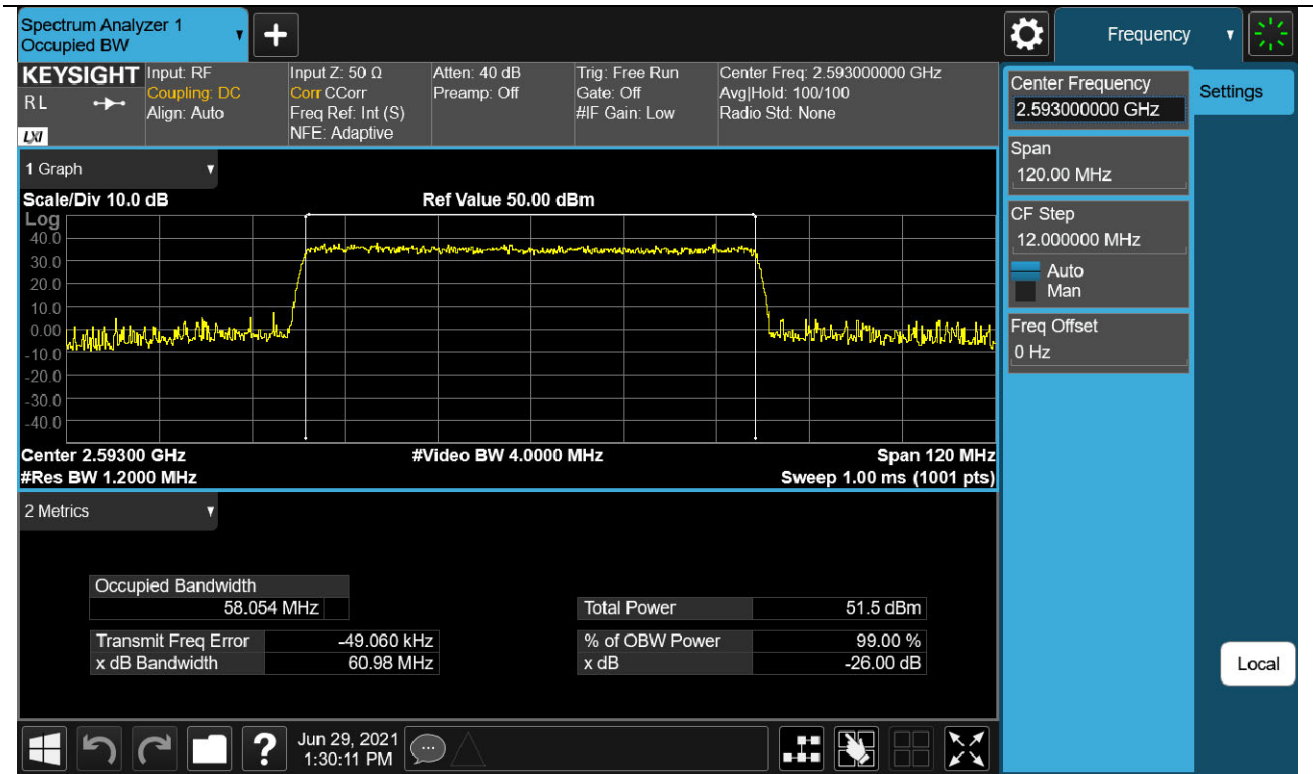

3 dB above the AGC threshold Input / BRS/EBS / Downlink / 5G NR 60 MHz

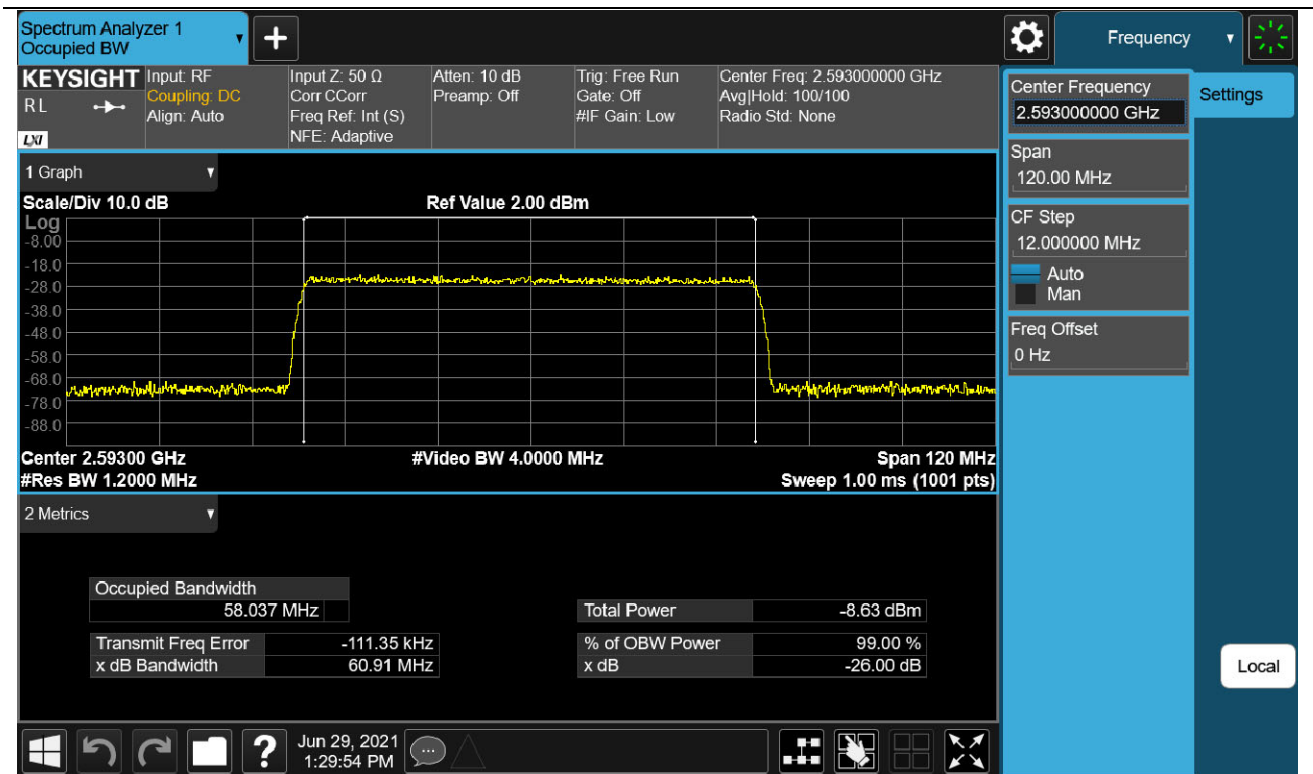

Output / BRS/EBS / Downlink / 5G NR 80 MHz

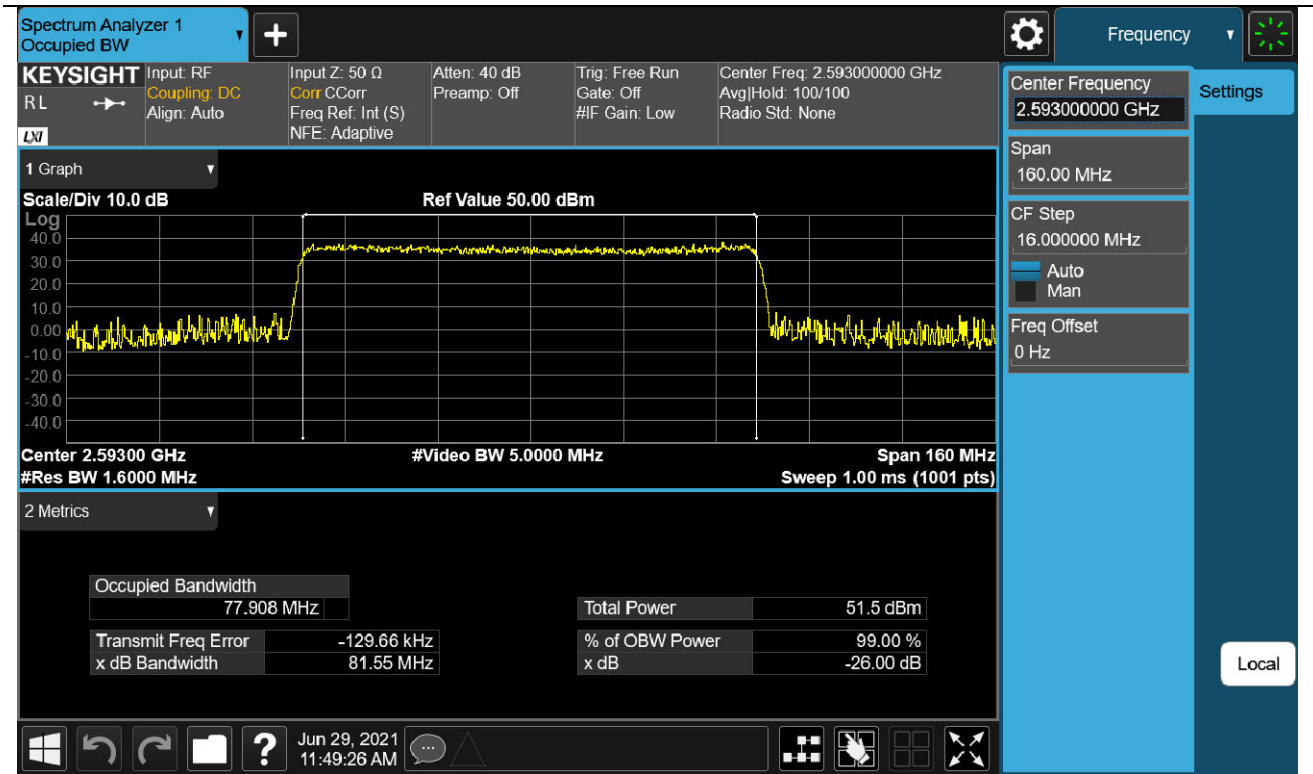

Input / BRS/EBS / Downlink / 5G NR 80 MHz

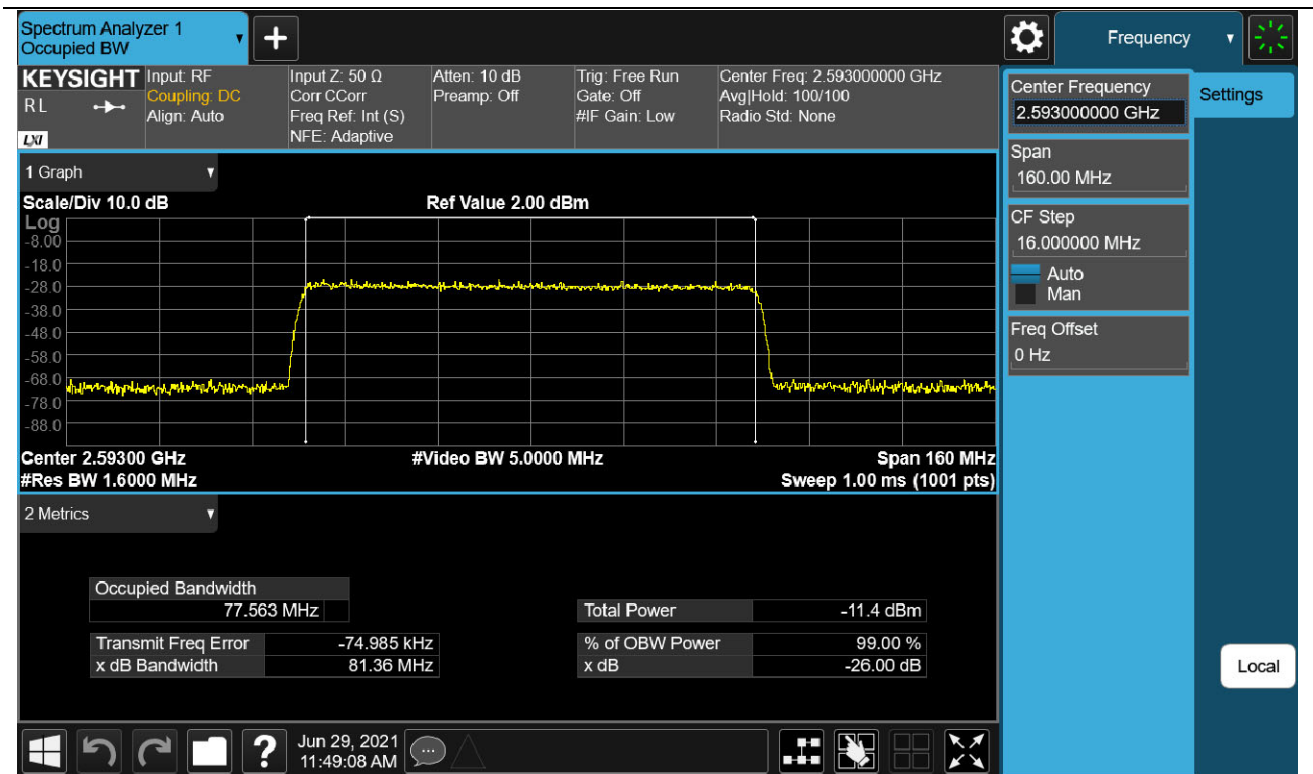

3 dB above the AGC threshold output / BRS/EBS / Downlink / 5G NR 80 MHz

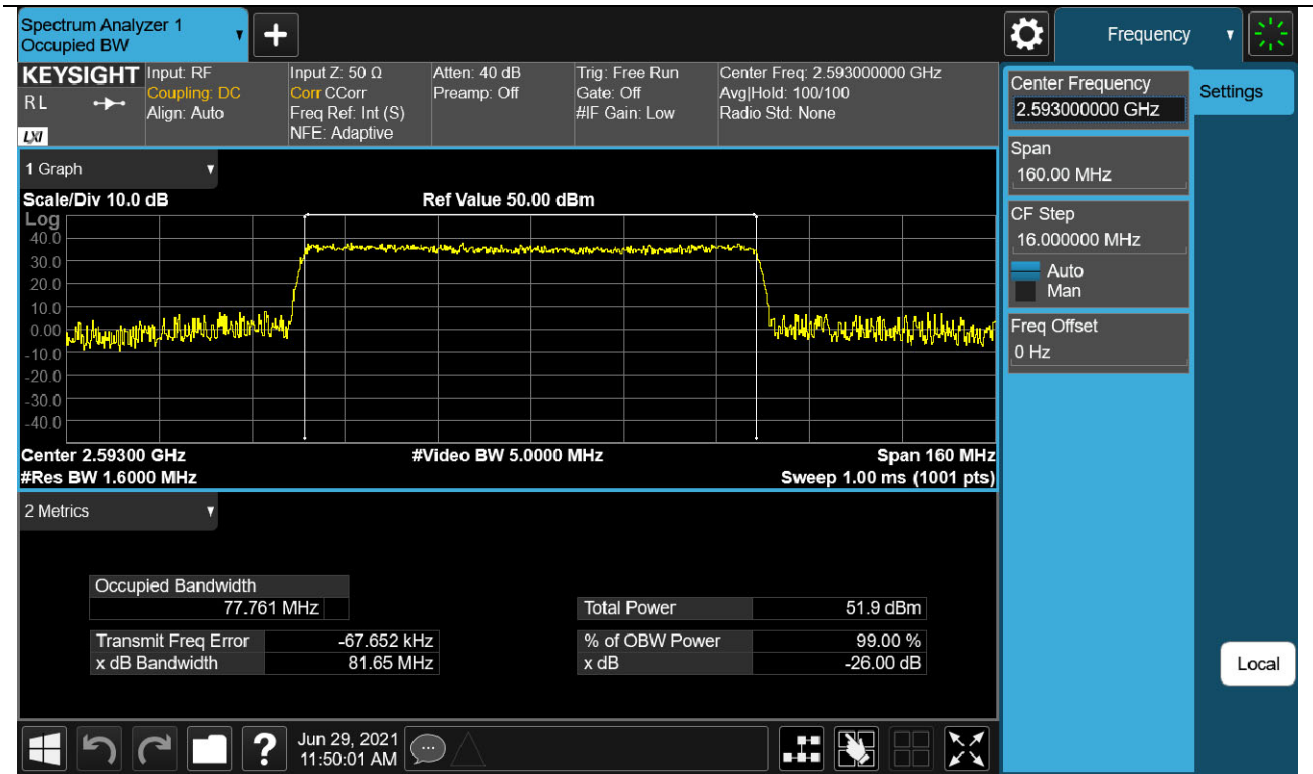

3 dB above the AGC threshold Input / BRS/EBS / Downlink / 5G NR 80 MHz

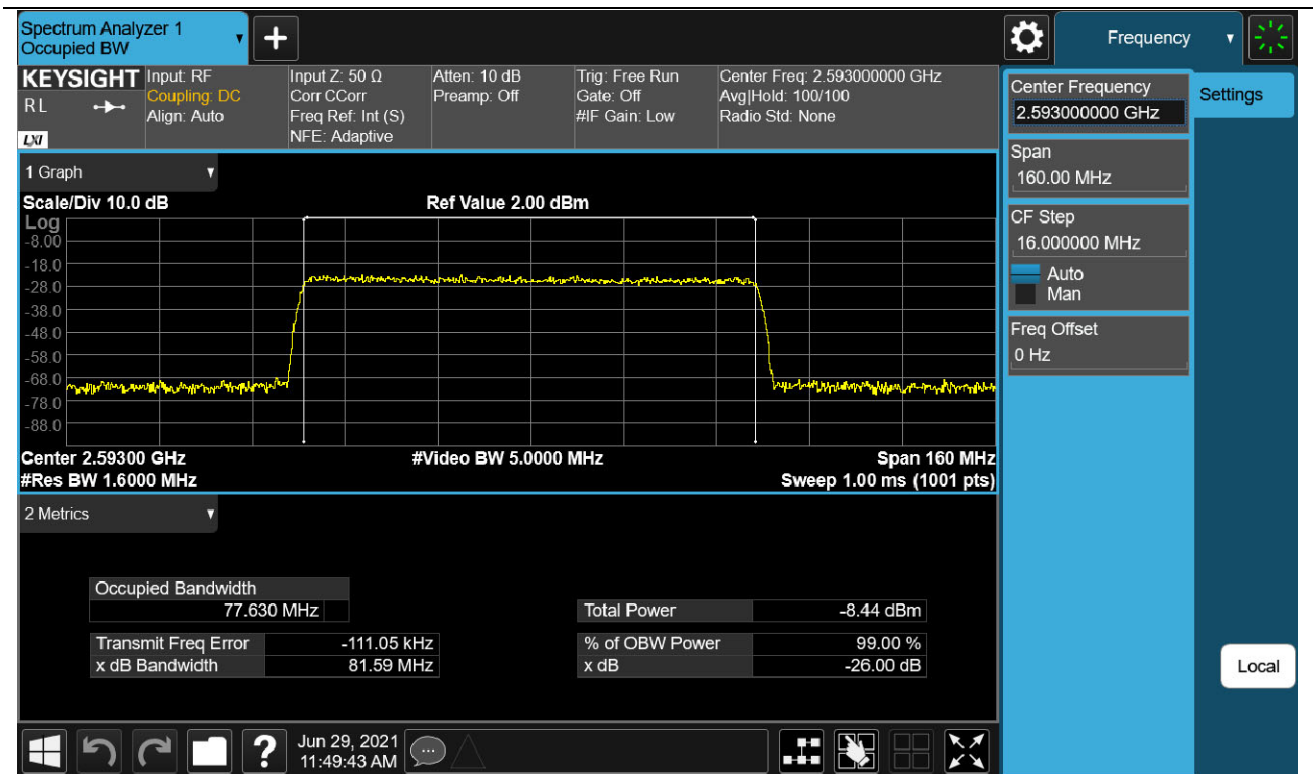

Output / BRS/EBS / Downlink / 5G NR 100 MHz

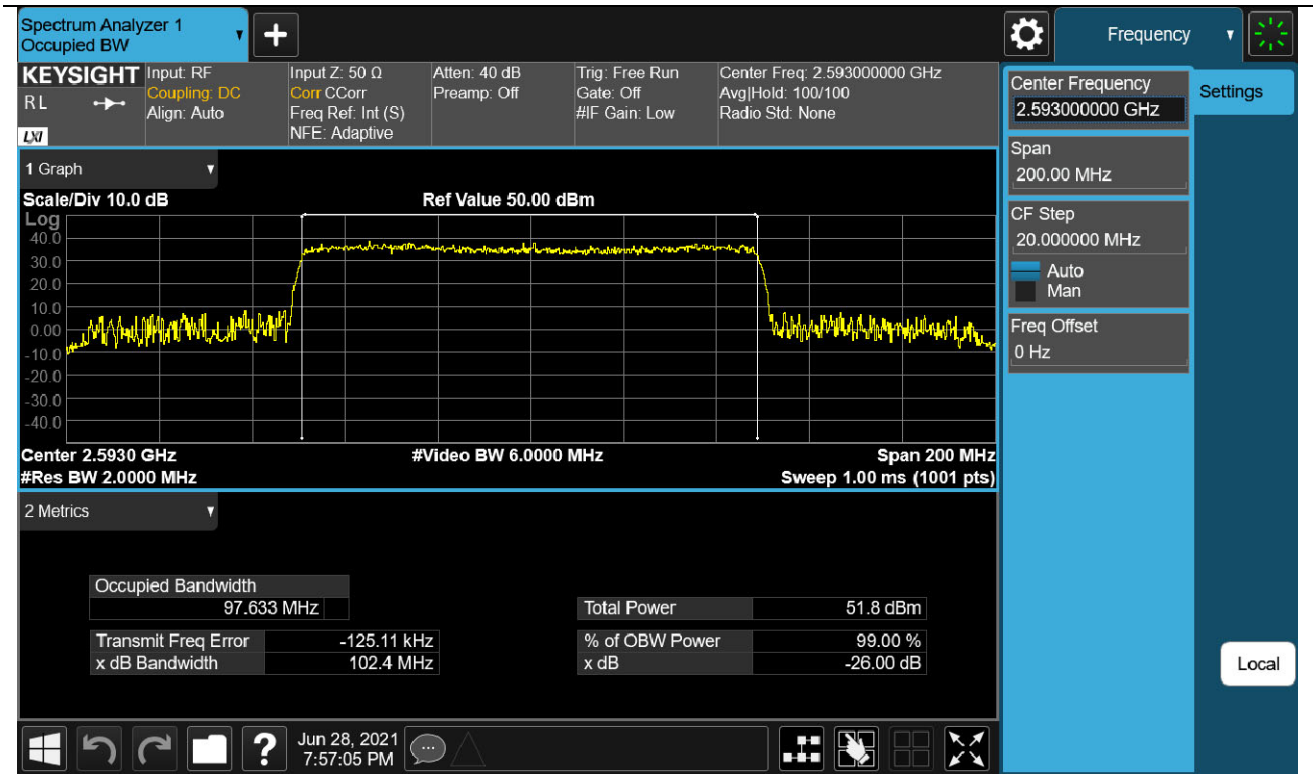

Input / BRS/EBS / Downlink / 5G NR 100 MHz

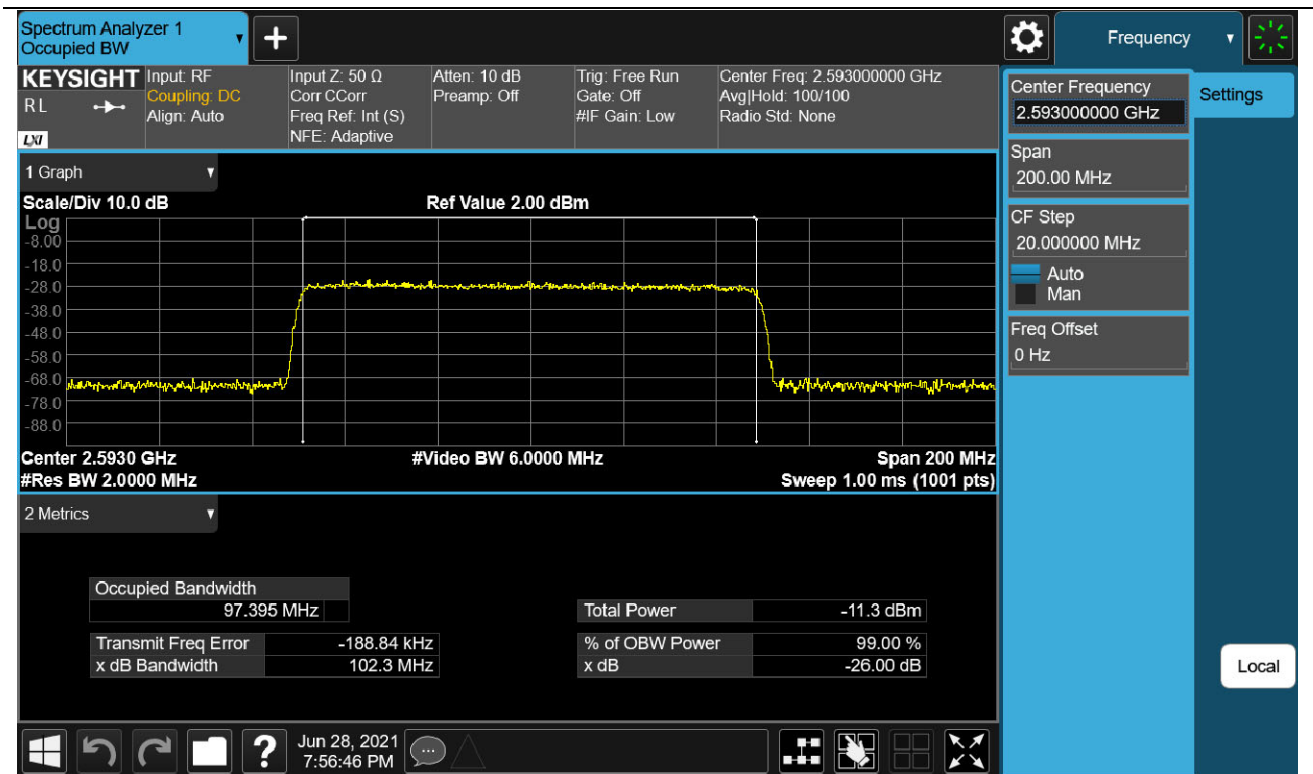

3 dB above the AGC threshold output / BRS/EBS / Downlink / 5G NR 100 MHz

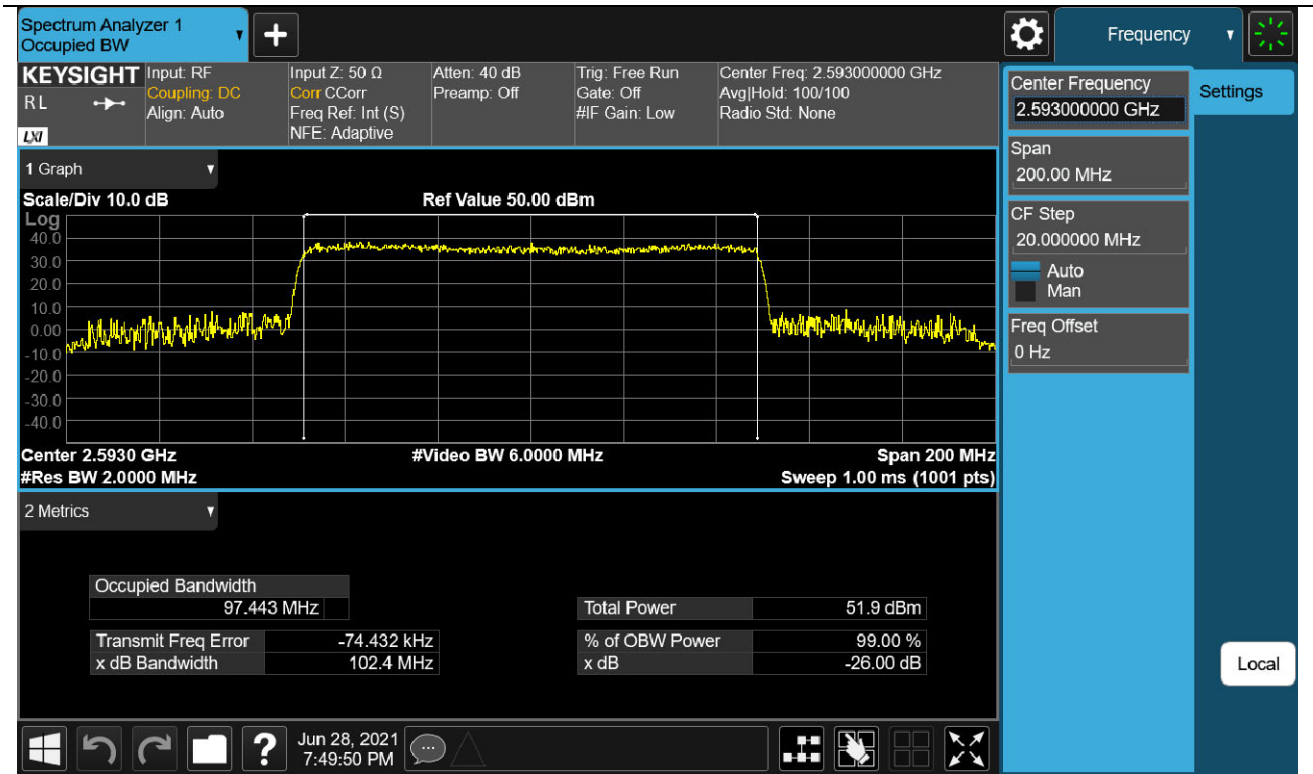

3 dB above the AGC threshold Input / BRS/EBS / Downlink / 5G NR 100 MHz

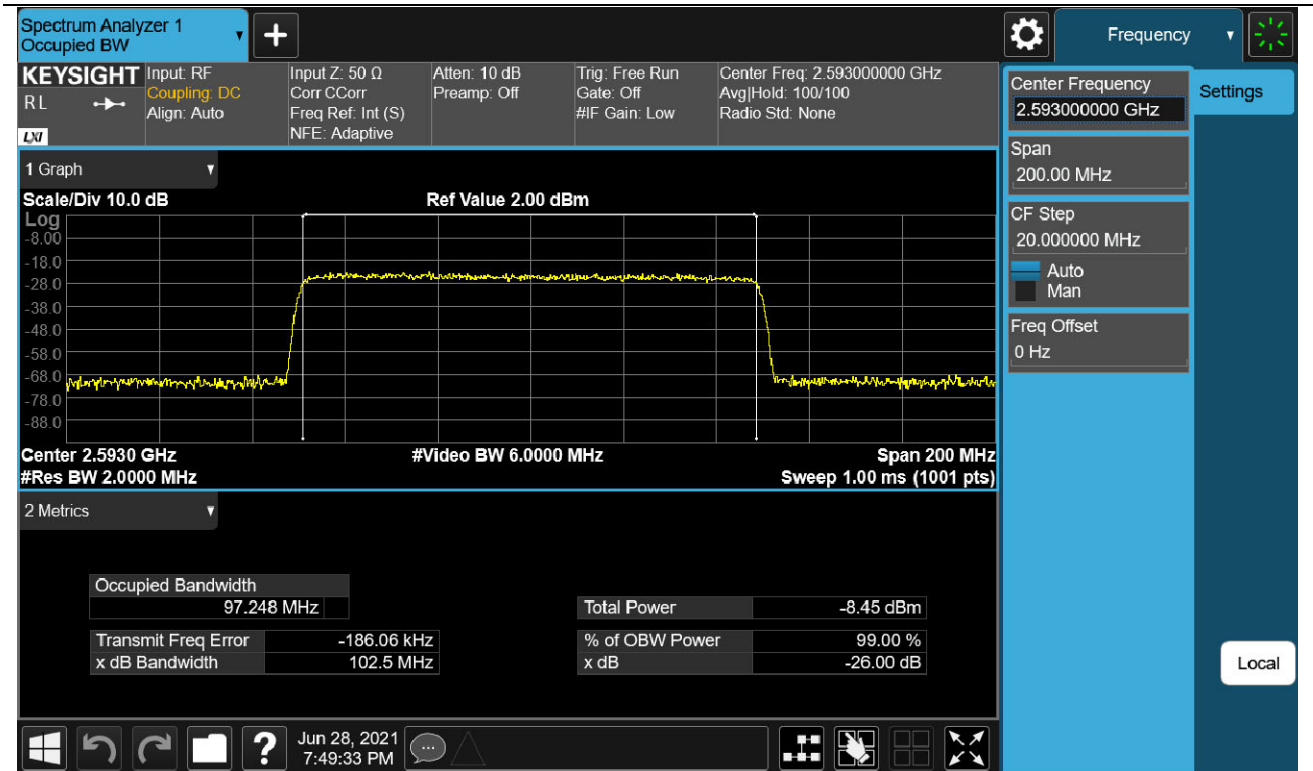

5.4. INPUT/OUTPUT POWER AND AMPLIFIER/BOOSTER GAIN

Test Requirement:

§ 2.1046 Measurements required: RF power output.

- (a) For transmitters other than single sideband, independent sideband and controlled carrier radiotelephone, power output shall be measured at the RF output terminals when the transmitter is adjusted in accordance with the tune-up procedure to give the values of current and voltage on the circuit elements specified in § 2.1033(c)(8). The electrical characteristics of the radio frequency load attached to the output terminals when this test is made shall be stated.
- (b) For single sideband, independent sideband, and single channel, controlled carrier radiotelephone transmitters the procedure specified in paragraph (a) of this section shall be employed and, in addition, the transmitter shall be modulated during the test as specified and applicable in § 2.1046 (b) (1-5). In all tests, the input level of the modulating signal shall be such as to develop rated peak envelope power or carrier power, as appropriate, for the transmitter.
- (c) For measurements conducted pursuant to paragraphs (a) and (b) of this section, all calculations and methods used by the applicant for determining carrier power or peak envelope power, as appropriate, on the basis of measured power in the radio frequency load attached to the transmitter output terminals shall be shown. Under the test conditions specified, no components of the emission spectrum shall exceed the limits specified in the applicable rule parts as necessary for meeting occupied bandwidth or emission limitations.

§ 27.50 Power limits and duty cycle.

- (h) The following power limits shall apply in the BRS and EBS:
 - (1) Main, booster and base stations.
 - (i) The maximum EIRP of a main, booster or base station shall not exceed $33 \text{ dBW} + 10\log(X/Y) \text{ dBW}$, where X is the actual channel width in MHz and Y is either 6 MHz if prior to transition or the station is in the MBS following transition or 5.5 MHz if the station is in the LBS and UBS following transition, except as provided in paragraph (h)(1)(ii) of this section.
 - (ii) If a main or booster station sectorizes or otherwise uses one or more transmitting antennas with a non-omnidirectional horizontal plane radiation pattern, the maximum EIRP in dBW in a given direction shall be determined by the following formula: $\text{EIRP} = 33 \text{ dBW} + 10 \log(X/Y) \text{ dBW} + 10 \log(360/\text{beamwidth}) \text{ dBW}$, where X is the actual channel width in MHz, Y is either (i) 6 MHz if prior to transition or the station is in the MBS following transition or (ii) 5.5 MHz if the station is in the LBS and UBS following transition, and beamwidth is the total horizontal plane beamwidth of the individual transmitting antenna for the station or any sector measured at the half-power points.

Test Procedures:

Measurements were in accordance with the test methods section 3.5 of KDB 935210 D05 v01r04.

Adjust the internal gain control of the EUT to the maximum gain for which the equipment certification is being sought. Any EUT attenuation settings shall be set to their minimum value.

Input power levels (uplink and downlink) should be set to maximum input ratings while confirming that the device is not capable of operating in saturation (non-linear mode) at the rated input levels, including during the performance of the input/output power measurements.

3.5.2 Measuring the EUT mean input and output power

- a) Connect a signal generator to the input of the EUT.
- b) Configure to generate the test signal.
- c) The frequency of the signal generator shall be set to the frequency f_0 as determined from out-of-band rejection test.
- d) Connect a spectrum analyzer or power meter to the output of the EUT using appropriate attenuation as necessary.
- e) Set the signal generator output power to a level that produces an EUT output level that is just below the AGC threshold, but not more than 0.5 dB below.
- f) Measure and record the output power of the EUT; use ANSI C63.26-2015 subclause 5.2.4.4.1, for power measurement.
- g) Remove the EUT from the measurement setup. Using the same signal generator settings, repeat the power measurement at the signal generator port, which was used as the input signal to the EUT, and record as the input power. EUT gain may be calculated as described in 3.5.5.
- h) Repeat steps f) and g) with input signal amplitude set to 3 dB above the AGC threshold level.
- i) Repeat steps e) to h) with the narrowband test signal.
- j) Repeat steps e) to i) for all frequency bands authorized for use by the EUT.

3.5.5 Calculating amplifier, repeater, or industrial booster gain

After the input and output power levels have been measured as described in the preceding subclauses, the gain of the EUT can be determined from:

$$\text{Gain (dB)} = \text{output power (dBm)} - \text{input power (dBm)}.$$

Report the gain for each authorized operating frequency band, and each test signal stimulus.

Note. If f_0 that determined from out-of-band test is smaller or greater than difference of test signal's center frequency and operation band block, test is performed at the lowest or the highest frequency that test signals can be passed.

EIRP Sample Calculation

Item	Formula	Value
27.50(h)(1)(i) Limit	$33 \text{ dBW} + 10 \log(X/Y) \text{ dBW}$ $= 33 \text{ dBW} + 10 \log(20/6) \text{ dBW} = 38.23 \text{ dBW}$	68.23 dBm
Final Calculated EIRP	Output Power + Antenna gain $= 43.44 \text{ dBm} + 17 \text{ dBi}$	60.77 dBm

Test Results:

Tabular data of Input / Output Power and Gain

Test Band	Signal	f ₀ Frequency	Input Power	Output Power	Gain	E.I.R.P		
		(MHz)	(dBm)		(dB)	(dBm)	(W/MHz)	(W)
BRS/EBS United	LTE 20 MHz	2569.84	-20.09	43.44	63.53	60.44	55.33	1106.62
	5G NR 20 MHz	2569.84	-20.01	43.38	63.39	60.38	54.57	1091.44
	5G NR 40 MHz	2569.84	-19.98	43.42	63.40	60.42	27.54	1101.54
	5G NR 60 MHz	2569.84	-19.98	43.37	63.35	60.37	18.15	1088.93
	5G NR 80 MHz	2569.84	-20.02	43.36	63.38	60.36	13.58	1086.43
	5G NR 100 MHz	2569.84	-20.24	43.40	63.64	60.40	10.96	1096.48

*E.I.R.P(dBm) = Output Power(dBm) + Ant. Gain(17 dBi)

Tabular data of Input / 3 dB above AGC threshold Output Power and Gain

Test Band	Signal	f ₀ Frequency	Input Power	Output Power	E.I.R.P		
		(MHz)	(dBm)		(dBm)	(W/MHz)	(W)
BRS/EBS United	LTE 20 MHz	2569.84	-17.10	42.83	59.83	48.08	961.61
	5G NR 20 MHz	2569.84	-16.97	43.04	60.04	50.46	1009.25
	5G NR 40 MHz	2569.84	-16.93	43.32	60.32	26.91	1076.47
	5G NR 60 MHz	2569.84	-16.96	43.20	60.20	17.45	1047.13
	5G NR 80 MHz	2569.84	-17.02	43.14	60.14	12.91	1032.76
	5G NR 100 MHz	2569.84	-17.06	43.26	60.26	10.62	1061.70

*E.I.R.P(dBm) = Output Power(dBm) + Ant. Gain(17 dBi)

Tabular data of PAPR

Test Band	Link	Signal	f ₀ Frequency (MHz)	0.1 % PAPR (dB)
BRS/EBS United	Downlink	LTE 20MHz	2569.84	8.35
		5G NR 20 MHz	2569.84	8.47
		5G NR 40 MHz	2569.84	8.29
		5G NR 60 MHz	2569.84	8.28
		5G NR 80 MHz	2569.84	8.25
		5G NR 100 MHz	2569.84	8.26