



FCC RADIO TEST REPORT

Applicant : Ubiquiti Inc.

Address : 685 Third Avenue, New York, New York 10017, USA

Equipment : UniFi Protect G3 mini

Model No. : UVC-G3-mini

Trade Name : UBIQUITI

FCC ID. : SWX-UVCG3MI

I HEREBY CERTIFY THAT :

The sample was received on Jul. 20, 2020 and the testing was completed on Aug. 06, 2020 at CerpPASS Technology Corp. The test result refers exclusively to the test presented test model / sample. Without written approval of CerpPASS Technology Corp., the test report shall not be reproduced except in full.

Approved by:

Mark Liao / Supervisor

Laboratory Accreditation:

CerpPASS Technology Corporation Test Laboratory





CONTENTS

- 1. Summary of Test Procedure and Test Results 5
 - 1.1. Applicable Standards 5
- 2. Test Configuration of Equipment under Test 6
 - 2.1. Feature of Equipment under Test..... 6
 - 2.2. Carrier Frequency of Channels 7
 - 2.3. Test Mode and Test Software 9
 - 2.4. Description of Test System..... 9
 - 2.5. General Information of Test..... 10
 - 2.6. Measurement Uncertainty 10
- 3. Test Equipment and Ancillaries Used for Tests 11
- 4. Antenna Requirements 13
 - 4.1. Standard Applicable 13
 - 4.2. Antenna Construction and Directional Gain..... 13
- 5. Test of AC Power Line Conducted Emission 14
 - 5.1. Test Limit 14
 - 5.2. Test Procedures 14
 - 5.3. Typical Test Setup 15
 - 5.4. Test Result and Data 16
 - 5.5. Test Photographs 18
- 6. Test of Spurious Emission (Radiated) 19
 - 6.1. Test Limit 19
 - 6.2. Test Procedures 20
 - 6.3. Typical Test Setup 21
 - 6.4. Test Result and Data (9kHz ~ 30MHz)..... 22
 - 6.5. Test Result and Data (30MHz ~ 1GHz)..... 22
 - 6.6. Test Result and Data (1GHz ~ 40GHz)..... 24
 - 6.7. Restricted Bands of Operation 108
 - 6.8. Test Photographs (30MHz ~ 1GHz) 109
 - 6.9. Test Photographs (1GHz ~ 40GHz) 110
- 7. On Time, Duty Cycle and Measurement methods 112
 - 7.1. Test Limit 112
 - 7.2. Test Procedure 112
 - 7.3. Test Setup Layout 112
 - 7.4. Test Result and Data 112
 - 7.5. Measurement Methods 112
- 8. 6dB Bandwidth & 99% Occupied Bandwidth 114
 - 8.1. Test Limit 114
 - 8.2. Test Procedure 114
 - 8.3. Test Setup Layout 114
 - 8.4. Test Result and Data (6dB Bandwidth) 115
 - 8.5. Test Result and Data (99% Occupied Bandwidth) 116
- 9. 26dB Bandwidth & 99% Occupied Bandwidth 123
 - 9.1. Test Limit 123



- 9.2. Test Procedure 123
- 9.3. Test Setup Layout 123
- 9.4. Test Result and Data (26dB Bandwidth) 124
- 9.5. Test Result and Data (99% Occupied Bandwidth) 126
- 10. Average Power..... 142
 - 10.1. Test Limit 142
 - 10.2. Test Procedure 143
 - 10.3. Test Setup Layout 143
 - 10.4. Test Result and Data 144
- 11. Power Spectral Density 152
 - 11.1. Test Limit 152
 - 11.2. Test Procedure 152
 - 11.3. Test Setup Layout 152
 - 11.4. Test Result and Data 153
- 12. Frequency Stability 164
 - 12.1. Test Procedure 164
 - 12.2. Test Setup Layout 164
 - 12.3. Test Result and Data 165
- 13. Radio Frequency Exposure 166
 - 13.1. Applicable Standards 166
 - 13.2. EUT Specification 166
 - 13.3. Test Results 166
 - 13.4. Calculation 167
 - 13.5. Maximum Permissible Exposure 168



1. Summary of Test Procedure and Test Results

1.1. Applicable Standards

ANSI C63.10:2013

FCC Rules and Regulations Part 15 Subpart E §15.407

KDB789033

FCC Rule	Description of Test	Result
15.203	Antenna Requirement	PASS
15.207(a)	AC Power Line Conducted Emission	PASS
15.407(b) 15.209	Radiated Spurious Emission	PASS
15.407(a)	26 dB & Occupied Bandwidth	PASS
15.407	6 dB Bandwidth	PASS
15.407 (a) & (a)(3)	Average Power	PASS
15.407(a)	Power Spectral Density	PASS
15.407(g)	Frequency Stability	PASS
2.1091	Radio Frequency Exposure	PASS

*The lab has reduced the uncertainty risk factor from test equipment, environment and staff technicians which according to the standard on contract. Therefore, the test result will only be determined by standard requirement.

*This EUT has been also tested and compiled with the requirement of FCC Part 15, Subpart B, recorded in a separate test report(TEFD2007197).



2. Test Configuration of Equipment under Test

2.1. Feature of Equipment under Test

Frequency Range	BT / BLE: 2400-2483.5MHz 802.11b/g/n: 2400-2483.5MHz 802.11a/n/ac: 5150-5250MHz, 5250-5350MHz, 5470-5725MHz, 5725-5850MHz
Modulation Type	BT: GFSK, $\pi/4$ -DQPSK, 8DPSK BLE: GFSK 802.11b: CCK, DQPSK, DBPSK 802.11g/n/a: BPSK, QPSK, 16QAM, 64QAM 802.11ac: BPSK, QPSK, 16QAM, 64QAM, 256QAM
Modulation Technology	DSSS, OFDM, FHSS, DTS
Data Rate	BT: GFSK: 1Mbps, $\pi/4$ -DQPSK: 2Mbps, 8DPSK: 3Mbps BLE: GFSK: 1Mbps, GFSK: 2Mbps WLAN: 802.11b: 1, 2, 5.5, 11Mbps 802.11g: 6, 9, 12, 18, 24, 36, 48, 54Mbps 802.11n: MCS0 – MCS7, HT20/40 802.11a: 6, 9, 12, 18, 24, 36, 48, 54Mbps 802.11ac: MCS0 – MCS9, VHT20/40/80
Antenna Type	Internal Antenna
Antenna Gain	For BT/BLE: 2402-2480MHz ANT A: 2.60dBi For WLAN 2.4G: 2412-2462MHz ANT A: 2.60dBi For WLAN 5G: 5150-5850MHz ANT A: 4.60dBi
USB TYPE-C Cable	Brand: N/A Model: N/A
Adapter	Brand: Ubiquiti Model: NY-PW0H1-05002000
Serial Number	2027A FCECDAFF2B64

Note:

1. WLAN and BT can simultaneously transmission.
2. EUT supports DFS Client Mode, without radar detection.
3. For more details, please refer to the User's manual of the EUT.

**2.2. Carrier Frequency of Channels**

Band: 5150MHz-5250MHz

802.11a, 802.11n HT20, 802.11ac VHT20

Channel	Frequency(MHz)	Channel	Frequency(MHz)
*36	5180	44	5220
*40	5200	*48	5240

802.11n HT40, 802.11ac VHT40

Channel	Frequency(MHz)	Channel	Frequency(MHz)
*38	5190	*46	5230

802.11ac VHT80

Channel	Frequency(MHz)
*42	5210

Band: 5250MHz -5350MHz

802.11a, 802.11n HT20, 802.11ac VHT20

Channel	Frequency(MHz)	Channel	Frequency(MHz)
*52	5260	*60	5300
56	5280	*64	5320

802.11n HT40, 802.11ac VHT40

Channel	Frequency(MHz)	Channel	Frequency(MHz)
*54	5270	*62	5310

802.11ac VHT80

Channel	Frequency(MHz)
*58	5290

Band: 5470MHz -5725MHz

802.11a, 802.11n HT20, 802.11ac VHT20

Channel	Frequency(MHz)	Channel	Frequency(MHz)
*100	5500	124	5620
104	5520	128	5640
108	5540	132	5660
112	5560	136	5680
116	5580	*140	5700
*120	5600		

802.11n HT40, 802.11ac VHT40

Channel	Frequency(MHz)	Channel	Frequency(MHz)
*102	5510	126	5630
110	5550	*134	5670
*118	5590		

802.11ac VHT80

Channel	Frequency(MHz)	Channel	Frequency(MHz)
*106	5530	*122	5610



Band 3: Straddle Channel

802.11a, 802.11n HT 20, 802.11ac VHT20

Channel	Frequency(MHz)
*144	5720

802.11n HT40, 802.11ac VHT40

Channel	Frequency(MHz)
*142	5710

802.11ac VHT80

Channel	Frequency(MHz)
*138	5690

Band: 5725MHz -5850MHz

802.11a, 802.11n HT20, 802.11ac VHT20

Channel	Frequency(MHz)	Channel	Frequency(MHz)
*149	5745	161	5805
153	5765	*165	5825
*157	5785		

802.11n HT40, 802.11ac VHT40

Channel	Frequency(MHz)	Channel	Frequency(MHz)
*151	5755	*159	5795

802.11ac VHT80

Channel	Frequency(MHz)
*155	5775

Note: Channels remarked * are selected to perform test.



2.3. Test Mode and Test Software

- a. During testing, the interface cables and equipment positions were varied according to ANSI C63.10.
- b. The complete test system included remote workstation and EUT for RF test. The remote workstation included Notebook.
- c. An executive program, " wl command" under Windows OS system was executed to transmit and receive data via WLAN.
- d. The following test modes were performed for the test:

Conducted Emissions from the AC mains power ports	
Test Mode	Operating Description
1	802.11a (6Mbps)
2	802.11ac VHT20 (6.5Mbps)
3	802.11ac VHT40 (13.5Mbps)
4	802.11ac VHT80 (29.3Mbps)
caused "Test Mode 1" generated the worst case, it was reported as the final data.	
Radiation Emissions (30MHz ~ 1GHz)	
Test Mode	Operating Description
1	802.11a (6Mbps)
2	802.11ac VHT20 (6.5Mbps)
3	802.11ac VHT40 (13.5Mbps)
4	802.11ac VHT80 (29.3Mbps)
caused "Test Mode 1" generated the worst case, it was reported as the final data.	
Radiation Emissions (1GHz ~ 40GHz)	
Test Mode	Operating Description
1	802.11a (6Mbps)
2	802.11ac VHT20 (6.5Mbps)
3	802.11ac VHT40 (13.5Mbps)
4	802.11ac VHT80 (29.3Mbps)
caused "Test Mode 1~4" generated the worst case, they were reported as the final data.	

2.4. Description of Test System

N/A

**2.5. General Information of Test**

Test Site	Cerpass Technology Corporation Test Laboratory Address: No.10, Ln. 2, Lianfu St., Luzhu Dist., Taoyuan City 33848, Taiwan (R.O.C.) Tel:+886-3-3226-888 Fax:+886-3-3226-881	
	FCC	TW1439, TW1079
	IC	4934E-1, 4934E-2
	VCCI	T-2205 for Telecommunication test C-4663 for Conducted emission test R-4218 for Radiated emission test G-10812, G-10813 for radiated disturbance above 1GHz
Frequency Range Investigated	Conducted: from 150kHz to 30 MHz Radiation: from 30 MHz to 40,000MHz	
Test Distance	The test distance of radiated emission from antenna to EUT is 3 M.	

Test Item	Test Site	Finish Date	Environmental Conditions	Tested By
RF Conducted	RFCON01-NK	2020/08/06	24°C / 62%	Nick Guan
Radiated Emissions	3M02-NK	2020/08/04	24°C / 44%	Leon Huang
AC Power Line Conducted Emission	CON01-NK	2020/07/27	27°C / 50%	Leon Huang

2.6. Measurement Uncertainty

Measurement Item	Uncertainty
AC Power Line Conduction(150K~30MHz)	±1.60dB
Radiated Spurious Emission(9KHz~30MHz)	±3.404dB
Radiated Spurious Emission(30MHz~1GHz)	±5.686dB
Radiated Spurious Emission(1GHz~40GHz)	±6.597dB
6dB Bandwidth	±4.404%
26dB Bandwidth	±4.422%
Occupied Bandwidth	±4.400%
Peak Output Power(Conducted Power Meter)	±1.02dB
Power Spectral Density	±1.954dB
Duty Cycle	±3.47%
Frequency Stability	±209.668Hz



3. Test Equipment and Ancillaries Used for Tests

Test Item	Radiated Emissions				
Test Site	Semi Anechoic Room(3M02-NK)				
Instrument	Manufacturer	Model No	Serial No	Calibration Date	Valid Date
Bilog Antenna	Schwarzbeck	VULB9168	275	2019/09/24	2020/09/23
Active Loop Antenna	EMCO	6507	40855	2020/05/21	2021/05/20
Horn Antenna	EMCO	3115	31589	2020/03/26	2021/03/25
Horn Antenna	EMCO	3116	31974	2019/09/17	2020/09/16
EMI Receiver	ROHDE & SCHWARZ	ESCI	100821	2019/09/16	2020/09/15
Spectrum Analyzer	ROHDE & SCHWARZ	FSV 40-N	101329	2020/07/07	2021/07/06
Preamplifier	EM Electronics corp.	EM330	60660	2020/03/16	2021/03/15
Preamplifier	EMC INSTRUMENTS	EMC051845SE	980333	2019/09/20	2020/09/19
Preamplifier	Agilent	8449B	3008A01954	2020/03/16	2021/03/15
Preamplifier	EMC INSTRUMENTS	EMC184045	980065	2019/11/07	2020/11/06
Bluetooth Tester	ROHDE & SCHWARZ	CBT	101133	2020/04/07	2021/04/06
Cable-3in1(30M-1G)	HARBOUR INDUSTRIES	LL142	CCE1316	2019/09/20	2020/09/19
Cable-0.5m(1G-18G)	HUBER SUHNER	SUCOFLEX 100	805443/4	2020/05/27	2021/05/26
Cable-3m(1G-18G)	HUBER SUHNER	SUCOFLEX 100	805796/4	2020/05/27	2021/05/26
Cable-8m(1G-18G)	HUBER SUHNER	SUCOFLEX 100	805795/4	2020/05/27	2021/05/26
Cable-0.5m(30M-40G)	HUBER SUHNER	SUCOFLEX 102	28420/2	2020/04/01	2021/03/31
Cable-3m(30M-40G)	HUBER SUHNER	SUCOFLEX 102	MY2608/2	2020/04/01	2021/03/31
Cable-0.5m(1G-40G)	Rapidtek	40GHZ 50CM	38MS-38MS50 314	2020/04/09	2021/04/08
E3	AUDIX	v8.2014-8-6	RK-000529	NA	NA

Test Item	RF Conducted				
Test Site	RFCON01-NK				
Instrument	Manufacturer	Model No	Serial No	Calibration Date	Valid Date
Spectrum Analyzer	ROHDE & SCHWARZ	FSV 40-N	101329	2020/07/07	2021/07/06
Bluetooth Tester	ROHDE & SCHWARZ	CBT	101133	2020/04/07	2021/04/06
CAX Signal Analyzer	KEYSIGHT	N9000B	MY57100339	2019/11/25	2020/11/24
Attenuator	KEYSIGHT	8491B	MY39250703	2020/04/17	2021/04/16
TEMP & HUMI CHAMBER	T-MACHINE	TMJ-9712	T-12-040111	2019/08/28	2020/08/27
Power Meter	Anritsu	ML2495A	1224005	2020/04/17	2021/04/16
Power Sensor	Anritsu	MA2411B	1207295	2020/04/17	2021/04/16



Test Item	AC Power Line Conducted Emission				
Test Site	CON01-NK				
Instrument	Manufacturer	Model No	Serial No	Calibration Date	Valid Date
EMI Receiver	ROHDE & SCHWARZ	ESCI	100821	2019/09/16	2020/09/15
Line Impedance Stabilization Network	Schwarzbeck	NSLK 8127	8127-516	2019/09/19	2020/09/18
Pulse Limiter	ROHDE & SCHWARZ	ESH3-Z2	101933	2019/09/11	2020/09/10
Cable-6m(9k~300M)	NA	EMC5D-BM-BM-6	130605	2019/09/11	2020/09/10
E3	AUDIX	v8.2014-8-6	RK-000531	NA	NA



4. Antenna Requirements

4.1. Standard Applicable

For intentional device, according to FCC 47 CFR Section 15.203, an intentional radiator shall be designed to ensure that no antenna other than that furnished by the responsible party shall be used with the device.

And according to FCC 47 CFR Section 15.407 (a), if transmitting antennas of directional gain greater than 6dBi are used, the power shall be reduced by the amount in dB that the directional gain of the antenna exceeds 6dBi.

4.2. Antenna Construction and Directional Gain

Antenna Type	Internal Antenna
Antenna Gain	5180-5825MHz: 4.60 dBi

For Power directional gain= G_{ant} = 4.60 dBi

For PSD directional gain = G_{ant} = 4.60 dBi



5. Test of AC Power Line Conducted Emission

5.1. Test Limit

Conducted Emissions were measured from 150 kHz to 30 MHz with a bandwidth of 9 KHz, according to the methods defined in ANSI C63.4-2014. The EUT was placed on a nonmetallic stand in a shielded room 0.8 meters above the ground plane. The interface cables and equipment positioning were varied within limits of reasonable applications to determine the position produced maximum conducted emissions.

Frequency (MHz)	Quasi Peak (dB μ V)	Average (dB μ V)
0.15 – 0.5	66-56*	56-46*
0.5 – 5.0	56	46
5.0 – 30.0	60	50

*Decreases with the logarithm of the frequency.

5.2. Test Procedures

- The EUT was placed 0.4 meter from the conducting wall of the shielding room was kept at least 80 centimeters from any other grounded conducting surface.
- Connect EUT to the power mains through a line impedance stabilization network (LISN).
- All the support units are connecting to the other LISN.
- The LISN provides 50 ohm coupling impedance for the measuring instrument.
- The FCC states that a 50 ohm, 50 micro-Henry LISN should be used.
- Both sides of AC line were checked for maximum conducted interference.
- The frequency range from 150 kHz to 30 MHz was searched.
- Set the test-receiver system to Peak Detect Function and Specified Bandwidth with Maximum Hold Mode.



5.3. Typical Test Setup

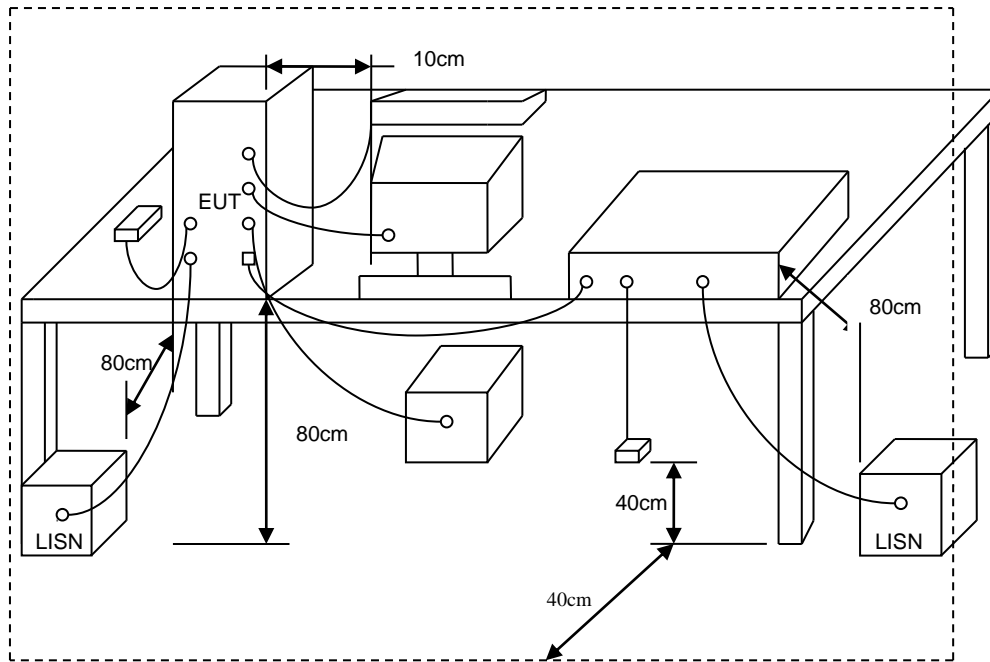



5.4. Test Result and Data

Power	: AC 120V / 60Hz	Pol/Phase	: LINE
Test Mode	: Mode 1, CH165		:

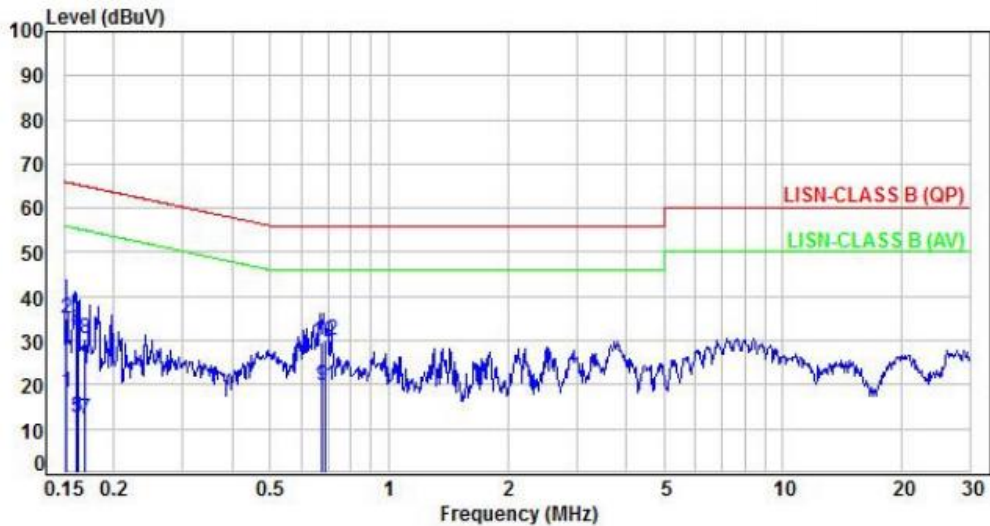

No.	Frequency (MHz)	Factor (dB)	Reading (dBUV)	Level (dBUV)	Limit (dBUV)	Margin (dB)	Detector	P/F
1	0.15	9.92	8.35	18.27	55.90	-37.63	Average	P
2	0.15	9.92	24.92	34.84	65.90	-31.06	QP	P
3	0.16	9.92	2.59	12.51	55.37	-42.86	Average	P
4	0.16	9.92	22.24	32.16	65.37	-33.21	QP	P
5	0.16	9.92	2.54	12.46	55.37	-42.91	Average	P
6	0.16	9.92	22.45	32.37	65.37	-33.00	QP	P
7	0.17	9.92	2.25	12.17	55.00	-42.83	Average	P
8	0.17	9.92	20.67	30.59	65.00	-34.41	QP	P
9	0.68	9.95	10.00	19.95	46.00	-26.05	Average	P
10	0.68	9.95	19.89	29.84	56.00	-26.16	QP	P
11	0.69	9.95	9.80	19.75	46.00	-26.25	Average	P
12	0.69	9.95	20.12	30.07	56.00	-25.93	QP	P

Note: Level=Reading+Factor
 Margin=Level-Limit
 Factor=(LISN or ISN or Current Probe)Factor + Cable Loss



Power	: AC 120V / 60Hz	Pol/Phase	: NEUTRAL
Test Mode	: Mode 1, CH165		

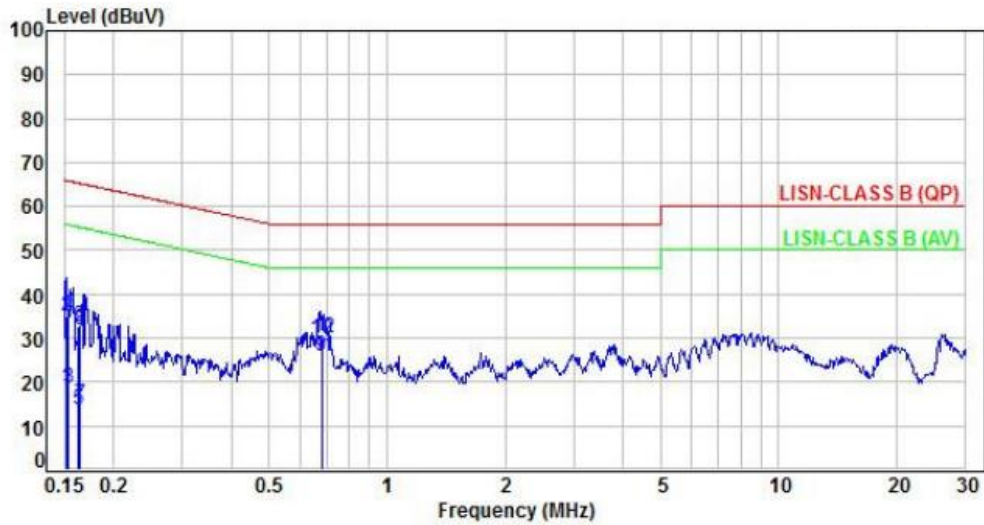

No.	Frequency (MHz)	Factor (dB)	Reading (dBuV)	Level (dBuV)	Limit (dBuV)	Margin (dB)	Detector	P/F
1	0.15	9.95	8.54	18.49	55.92	-37.43	Average	P
2	0.15	9.95	25.06	35.01	65.92	-30.91	QP	P
3	0.15	9.95	8.56	18.51	55.78	-37.27	Average	P
4	0.15	9.95	25.05	35.00	65.78	-30.78	QP	P
5	0.16	9.95	3.89	13.84	55.36	-41.52	Average	P
6	0.16	9.95	22.76	32.71	65.36	-32.65	QP	P
7	0.16	9.95	4.80	14.75	55.24	-40.49	Average	P
8	0.16	9.95	21.95	31.90	65.24	-33.34	QP	P
9	0.68	9.97	15.76	25.73	46.00	-20.27	Average	P
10	0.68	9.97	19.77	29.74	56.00	-26.26	QP	P
11	0.68	9.97	16.02	25.99	46.00	-20.01	Average	P
12	0.68	9.97	20.17	30.14	56.00	-25.86	QP	P

Note: Level=Reading+Factor
 Margin=Level-Limit
 Factor=(LISN or ISN or Current Probe)Factor + Cable Loss



6. Test of Spurious Emission (Radiated)

6.1. Test Limit

Undesirable emission limits. Except as shown in paragraph (b)(7) of this section, the maximum emissions outside of the frequency bands of operation shall be attenuated in accordance with the following limits:

- (1) For transmitters operating in the 5.15-5.25 GHz band: All emissions outside of the 5.15-5.35 GHz band shall not exceed an e.i.r.p. of -27 dBm/MHz.
- (2) For transmitters operating in the 5.25-5.35 GHz band: All emissions outside of the 5.15-5.35 GHz band shall not exceed an e.i.r.p. of -27 dBm/MHz.
- (3) For transmitters operating in the 5.47-5.725 GHz band: All emissions outside of the 5.47-5.725 GHz band shall not exceed an e.i.r.p. of -27 dBm/MHz.
- (4) For transmitters operating in the 5.725-5.85 GHz band:
All emissions shall be limited to a level of -27 dBm/MHz at 75 MHz or more above or below the band edge increasing linearly to 10 dBm/MHz at 25 MHz above or below the band edge, and from 25MHz above or below the band edge increasing linearly to a level of 15.6 dBm/MHz at 5 MHz above or below the band edge, and from 5 MHz above or below the band edge increasing linearly to a level of 27dBm/MHz at the band edge.
- (5) The emission measurements shall be performed using a minimum resolution bandwidth of 1 MHz. A lower resolution bandwidth may be employed near the band edge, when necessary, provided the measured energy is integrated to show the total power over 1 MHz.
- (6) Unwanted emissions below 1 GHz must comply with the general field strength limits set forth in §15.209. Further, any U-NII devices using an AC power line are required to comply also with the conducted limits set forth in §15.207.
- (7) The provisions of §15.205 apply to intentional radiators operating under this section.
- (8) When measuring the emission limits, the nominal carrier frequency shall be adjusted as close to the upper and lower frequency band edges as the design of the equipment permits.



6.2. Test Procedures

- a. The EUT was placed on a rotatable table top 0.8 meter above ground.
- b. The EUT was set 3 meters from the interference receiving antenna which was mounted on the top of a variable height antenna tower.
- c. The table was rotated 360 degrees to determine the position of the highest radiation.
- d. The antenna is a broadband antenna and its height is varied between one meter and four meters above ground to find the maximum value of the field strength both horizontal polarization and vertical polarization of the antenna are set to make the measurement.
- e. For each suspected emission the EUT was arranged to its worst case and then tune the antenna tower (from 1 M to 4 M) and turn table (from 0 degree to 360 degrees) to find the maximum reading.
- f. Set the test-receiver system to Peak or CISPR quasi-peak Detect Function and specified bandwidth with Maximum Hold Mode.
- g. If the emission level of the EUT in peak mode was 3 dB lower than the limit specified, then testing will be stopped and peak values of EUT will be reported, otherwise, the emissions which do not have 3 dB margin will be repeated one by one using the quasi-peak method and reported.
- h. For testing above 1GHz, the emission level of the EUT in peak mode was 20dB lower than average limit (that means the emission level in peak mode also complies with the limit in average mode), then testing will be stopped and peak values of EUT will be reported, otherwise, the emissions will be measured in average mode again and reported.
- i. "Cone of radiation" has been considered to be 3dB bandwidth of the measurement antenna.



6.3. Typical Test Setup

Below 30MHz test setup

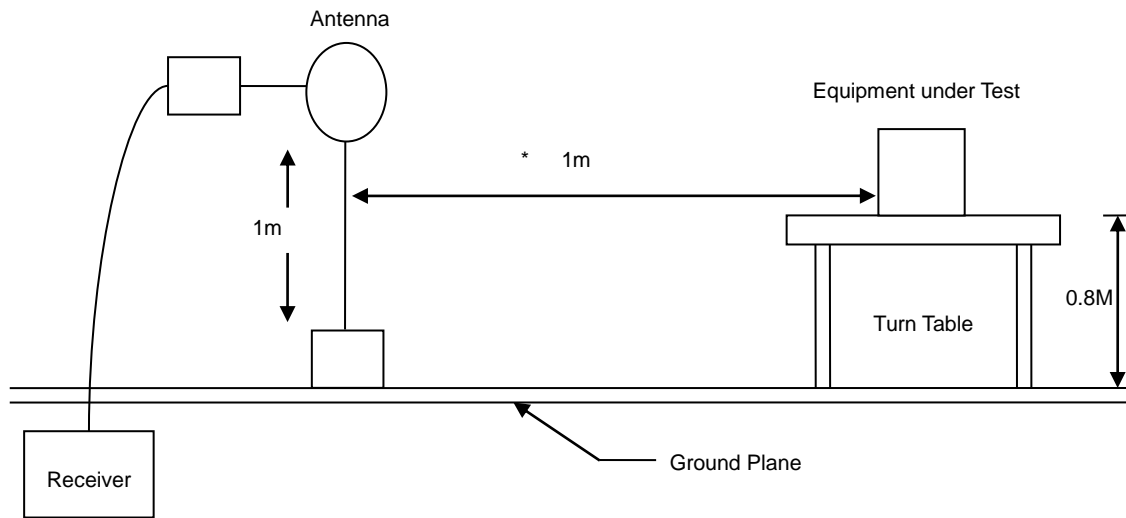

30MHz- 1GHz Test Setup

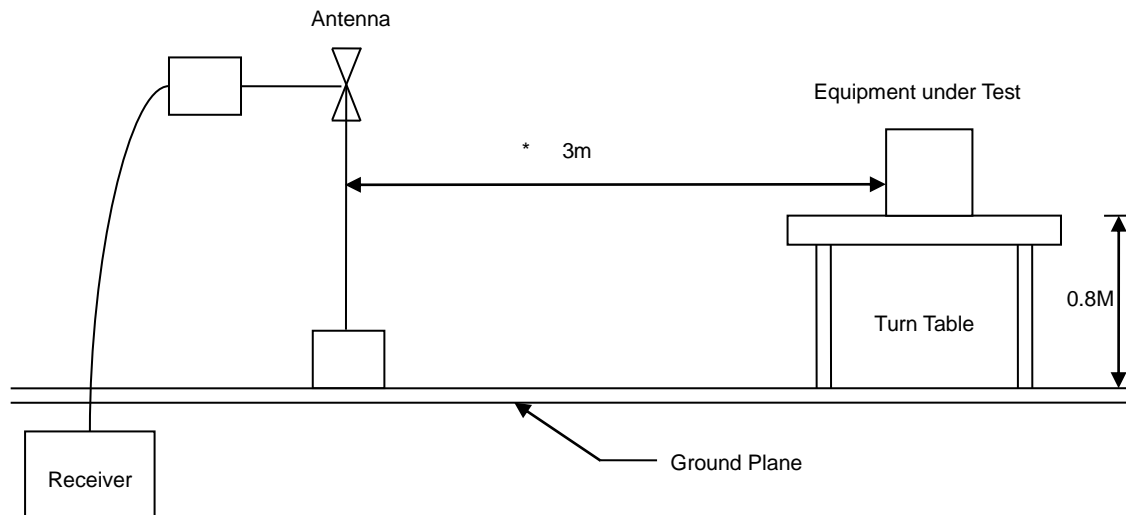

Above 1GHz Test Setup

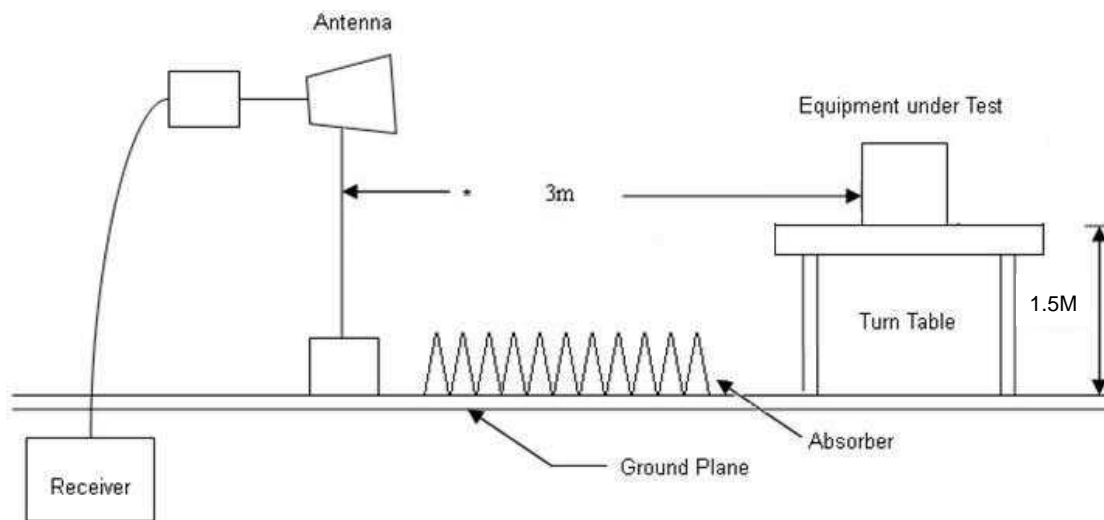



6.4. Test Result and Data (9kHz ~ 30MHz)

The 9kHz - 30MHz spurious emission is under limit 20dB more.

6.5. Test Result and Data (30MHz ~ 1GHz)

Power	: AC 120V / 60Hz	Pol/Phase	: VERTICAL
Test Mode	: Mode 1, CH165		:

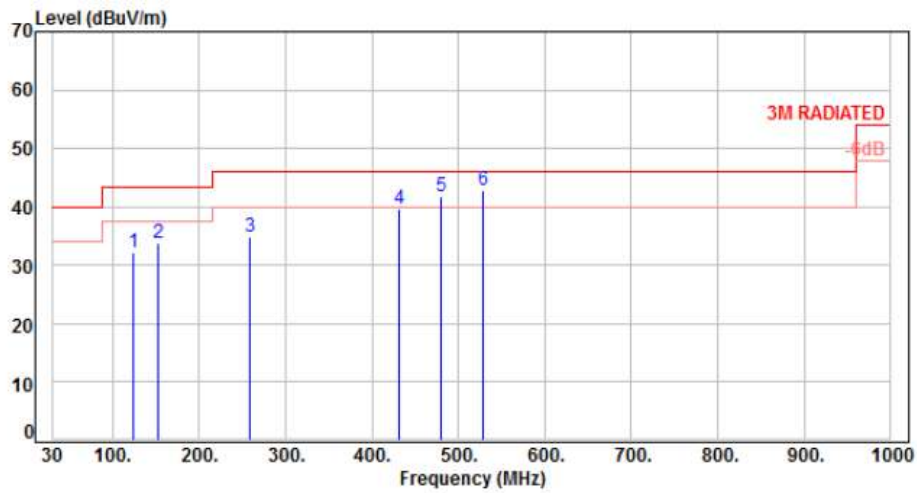

No.	Frequency (MHz)	Factor (dB)	Reading (dBuV)	Level (dBuV/m)	Limit (dBuV/m)	Margin (dB)	Detector	Height (cm)	Azimuth (deg)	P/F
1	123.12	-11.90	44.19	32.29	43.50	-11.21	Peak	400	0	P
2	153.19	-9.69	43.49	33.80	43.50	-9.70	Peak	400	0	P
3	258.92	-10.11	45.02	34.91	46.00	-11.09	Peak	400	0	P
4	431.58	-5.16	44.89	39.73	46.00	-6.27	Peak	400	0	P
5	480.08	-4.27	46.15	41.88	46.00	-4.12	Peak	400	0	P
6	528.00	-3.35	46.20	42.85	46.00	-3.15	QP	115	110	P

Note: Level=Reading+Factor
Margin=Level-Limit
Factor=Antenna Factor + cable loss - Amplifier Factor



Power	: AC 120V / 60Hz	Pol/Phase	: HORIZONTAL
Test Mode	: Mode 1, CH165		:

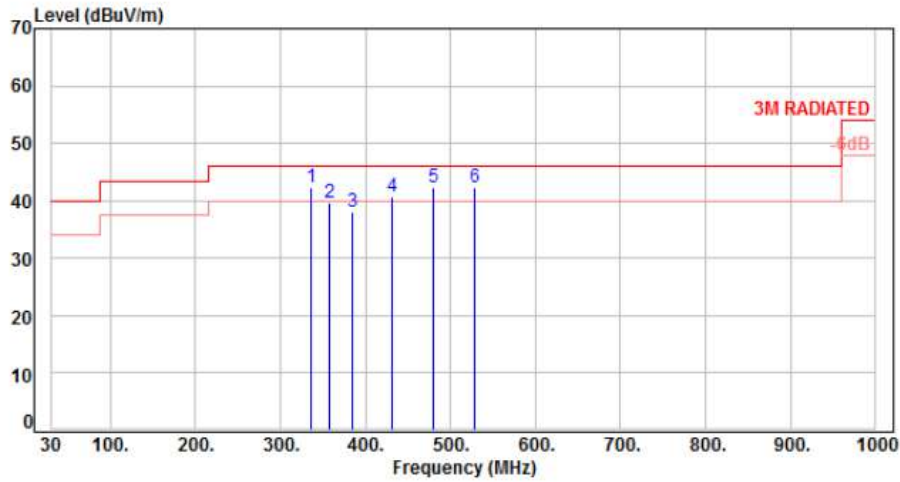

No.	Frequency (MHz)	Factor (dB)	Reading (dBuV)	Level (dBuV/m)	Limit (dBuV/m)	Margin (dB)	Detector	Height (cm)	Azimuth (deg)	P/F
1	335.55	-7.66	50.06	42.40	46.00	-3.60	Peak	100	0	P
2	356.89	-7.15	46.72	39.57	46.00	-6.43	Peak	100	0	P
3	384.05	-6.31	44.49	38.18	46.00	-7.82	Peak	100	0	P
4	431.58	-5.16	45.92	40.76	46.00	-5.24	Peak	100	0	P
5	480.08	-4.27	46.55	42.28	46.00	-3.72	Peak	100	0	P
6	528.00	-3.35	45.70	42.35	46.00	-3.65	QP	100	195	P

Note: Level=Reading+Factor
Margin=Level-Limit
Factor=Antenna Factor + cable loss - Amplifier Factor



6.6. Test Result and Data (1GHz ~ 40GHz)

Power	: AC 120V / 60Hz	Pol/Phase	: VERTICAL
Test Mode	: Mode 1, Band 1, CH36		:

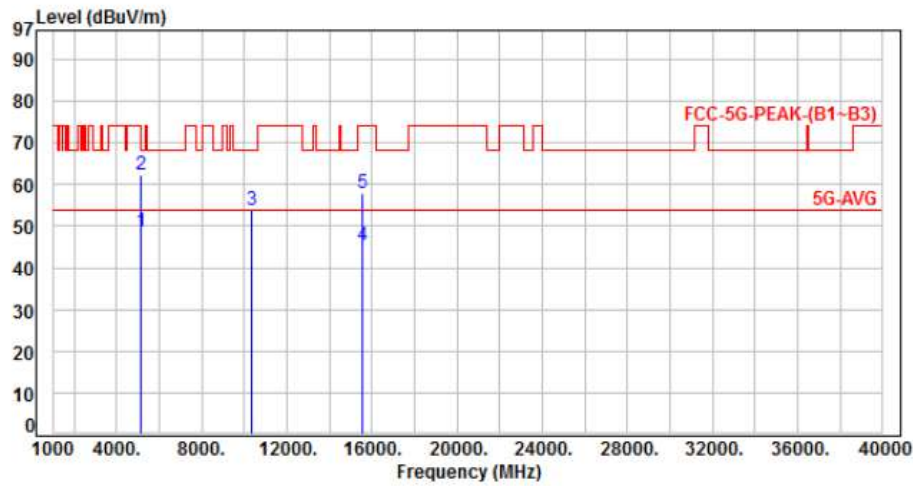

No.	Frequency (MHz)	Factor (dB)	Reading (dBuV)	Level (dBuV/m)	Limit (dBuV/m)	Margin (dB)	Detector	Height (cm)	Azimuth (deg)	P/F
1	5150.00	5.92	42.75	48.67	54.00	-5.33	Average	100	66	P
2	5150.00	5.92	56.40	62.32	74.00	-11.68	Peak	100	66	P
3	10360.00	12.95	40.95	53.90	68.20	-14.30	Peak	100	145	P
4	15540.00	15.69	29.65	45.34	54.00	-8.66	Average	100	122	P
5	15540.00	15.69	42.35	58.04	74.00	-15.96	Peak	100	122	P

Note: Level=Reading+Factor
Margin=Level-Limit
Factor=Antenna Factor + cable loss - Amplifier Factor



Power	: AC 120V / 60Hz	Pol/Phase	: HORIZONTAL
Test Mode	: Mode 1, Band 1, CH36		:

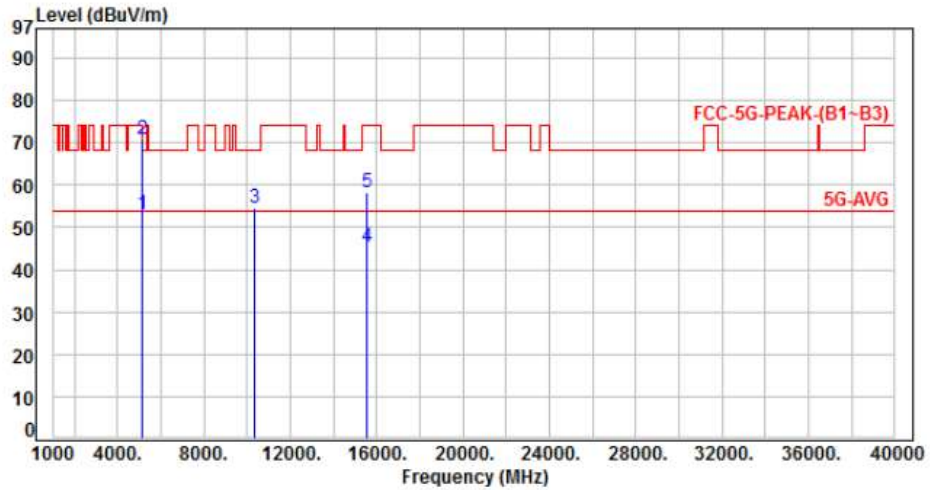

No.	Frequency (MHz)	Factor (dB)	Reading (dBuV)	Level (dBuV/m)	Limit (dBuV/m)	Margin (dB)	Detector	Height (cm)	Azimuth (deg)	P/F
1	5150.00	5.92	47.07	52.99	54.00	-1.01	Average	100	0	P
2	5150.00	5.92	64.95	70.87	74.00	-3.13	Peak	100	0	P
3	10360.00	12.95	41.73	54.68	68.20	-13.52	Peak	100	138	P
4	15540.00	15.69	29.78	45.47	54.00	-8.53	Average	100	86	P
5	15540.00	15.69	42.41	58.10	74.00	-15.90	Peak	100	86	P

Note: Level=Reading+Factor
Margin=Level-Limit
Factor=Antenna Factor + cable loss - Amplifier Factor



Power	: AC 120V / 60Hz	Pol/Phase	: VERTICAL
Test Mode	: Mode 1, Band 1, CH40		:

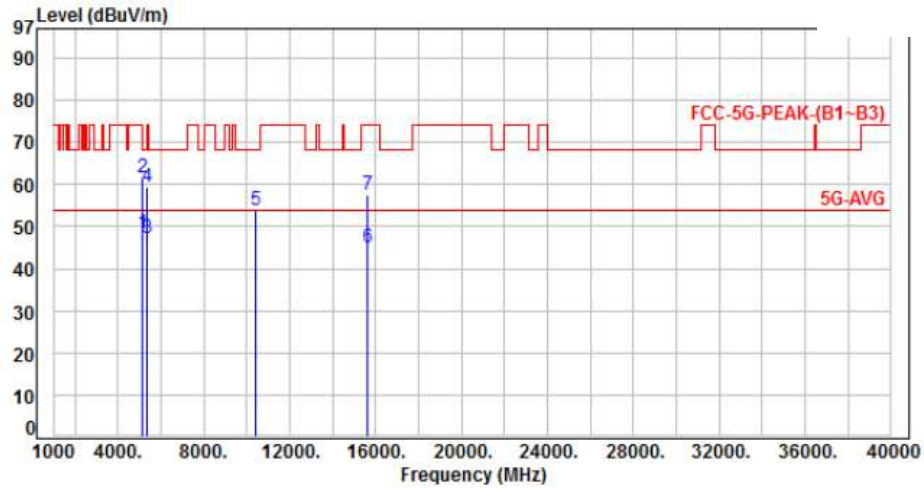

No.	Frequency (MHz)	Factor (dB)	Reading (dBuV)	Level (dBuV/m)	Limit (dBuV/m)	Margin (dB)	Detector	Height (cm)	Azimuth (deg)	P/F
1	5150.00	5.92	42.33	48.25	54.00	-5.75	Average	100	65	P
2	5150.00	5.92	55.80	61.72	74.00	-12.28	Peak	100	65	P
3	5350.00	6.22	41.06	47.28	54.00	-6.72	Average	100	65	P
4	5350.00	6.22	53.30	59.52	74.00	-14.48	Peak	100	65	P
5	10400.00	13.00	40.97	53.97	68.20	-14.23	Peak	100	101	P
6	15600.00	15.35	29.68	45.03	54.00	-8.97	Average	100	72	P
7	15600.00	15.35	42.08	57.43	74.00	-16.57	Peak	100	72	P

Note: Level=Reading+Factor
 Margin=Level-Limit
 Factor=Antenna Factor + cable loss - Amplifier Factor



Power	: AC 120V / 60Hz	Pol/Phase	: HORIZONTAL
Test Mode	: Mode 1, Band 1, CH40		:

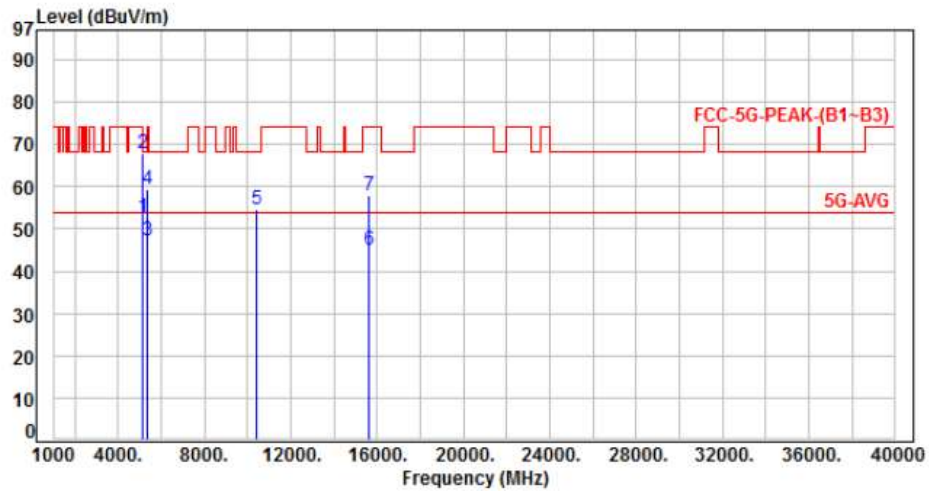

No.	Frequency (MHz)	Factor (dB)	Reading (dBuV)	Level (dBuV/m)	Limit (dBuV/m)	Margin (dB)	Detector	Height (cm)	Azimuth (deg)	P/F
1	5150.00	5.92	46.85	52.77	54.00	-1.23	Average	100	0	P
2	5150.00	5.92	61.78	67.70	74.00	-6.30	Peak	100	0	P
3	5350.00	6.22	40.94	47.16	54.00	-6.84	Average	100	0	P
4	5350.00	6.22	52.99	59.21	74.00	-14.79	Peak	100	0	P
5	10400.00	13.00	41.67	54.67	68.20	-13.53	Peak	100	118	P
6	15600.00	15.35	29.74	45.09	54.00	-8.91	Average	100	66	P
7	15600.00	15.35	42.38	57.73	74.00	-16.27	Peak	100	66	P

Note: Level=Reading+Factor
 Margin=Level-Limit
 Factor=Antenna Factor + cable loss - Amplifier Factor



Power	: AC 120V / 60Hz	Pol/Phase	: VERTICAL
Test Mode	: Mode 1, Band 1, CH48		:

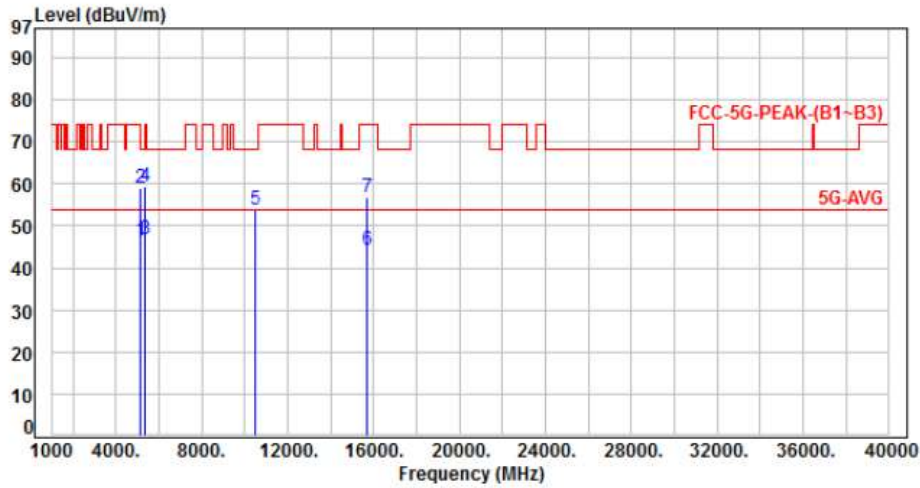

No.	Frequency (MHz)	Factor (dB)	Reading (dBUV)	Level (dBUV/m)	Limit (dBUV/m)	Margin (dB)	Detector	Height (cm)	Azimuth (deg)	P/F
1	5150.00	5.92	40.54	46.46	54.00	-7.54	Average	100	76	P
2	5150.00	5.92	53.12	59.04	74.00	-14.96	Peak	100	76	P
3	5350.00	6.22	40.79	47.01	54.00	-6.99	Average	100	76	P
4	5350.00	6.22	53.20	59.42	74.00	-14.58	Peak	100	76	P
5	10480.00	13.21	40.82	54.03	68.20	-14.17	Peak	100	108	P
6	15720.00	14.83	29.51	44.34	54.00	-9.66	Average	100	75	P
7	15720.00	14.83	41.92	56.75	74.00	-17.25	Peak	100	75	P

Note: Level=Reading+Factor
 Margin=Level-Limit
 Factor=Antenna Factor + cable loss - Amplifier Factor



Power	: AC 120V / 60Hz	Pol/Phase	: HORIZONTAL
Test Mode	: Mode 1, Band 1, CH48		:

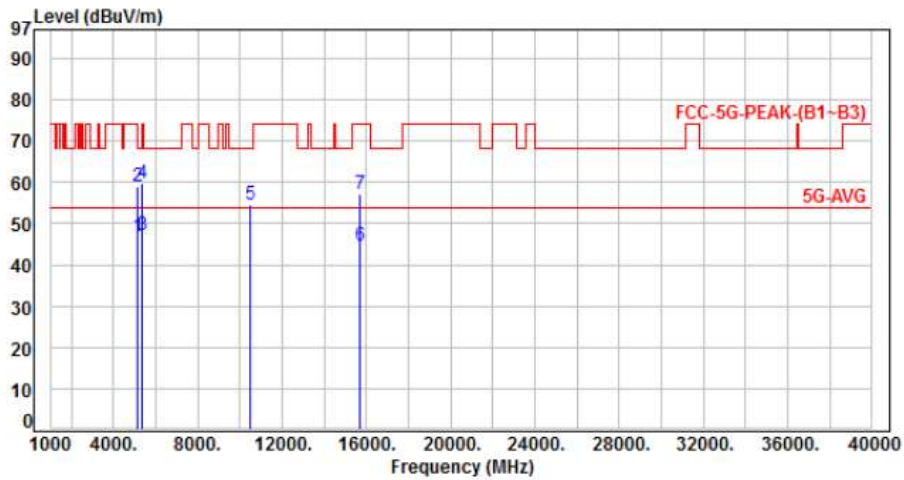

No.	Frequency (MHz)	Factor (dB)	Reading (dBuV)	Level (dBuV/m)	Limit (dBuV/m)	Margin (dB)	Detector	Height (cm)	Azimuth (deg)	P/F
1	5150.00	5.92	40.93	46.85	54.00	-7.15	Average	100	0	P
2	5150.00	5.92	53.06	58.98	74.00	-15.02	Peak	100	0	P
3	5350.00	6.22	40.86	47.08	54.00	-6.92	Average	100	0	P
4	5350.00	6.22	53.53	59.75	74.00	-14.25	Peak	100	0	P
5	10480.00	13.21	41.51	54.72	68.20	-13.48	Peak	100	115	P
6	15720.00	14.83	29.83	44.66	54.00	-9.34	Average	100	64	P
7	15720.00	14.83	42.47	57.30	74.00	-16.70	Peak	100	64	P

Note: Level=Reading+Factor
 Margin=Level-Limit
 Factor=Antenna Factor + cable loss - Amplifier Factor



Power	: AC 120V / 60Hz	Pol/Phase	: VERTICAL
Test Mode	: Mode 2, Band 1, CH36		:

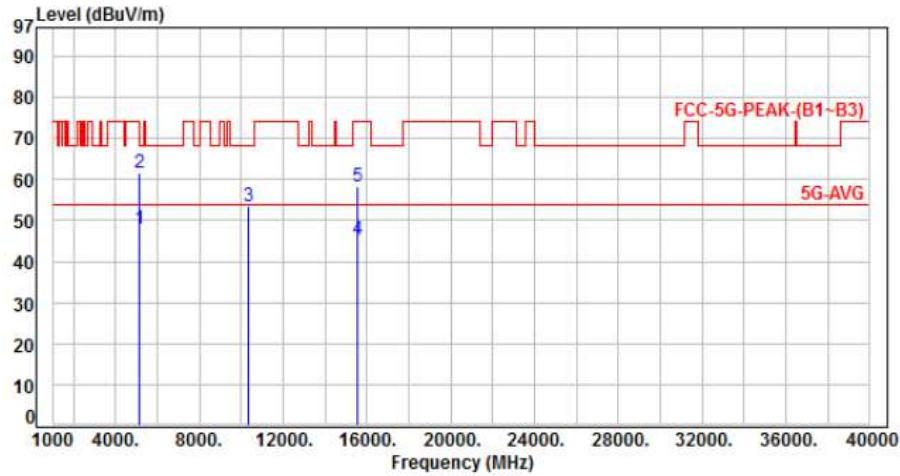

No.	Frequency (MHz)	Factor (dB)	Reading (dBuV)	Level (dBuV/m)	Limit (dBuV/m)	Margin (dB)	Detector	Height (cm)	Azimuth (deg)	P/F
1	5150.00	5.92	42.17	48.09	54.00	-5.91	Average	100	65	P
2	5150.00	5.92	55.70	61.62	74.00	-12.38	Peak	100	65	P
3	10360.00	12.95	40.70	53.65	68.20	-14.55	Peak	100	142	P
4	15540.00	15.69	29.72	45.41	54.00	-8.59	Average	100	120	P
5	15540.00	15.69	42.51	58.20	74.00	-15.80	Peak	100	120	P

Note: Level=Reading+Factor
Margin=Level-Limit
Factor=Antenna Factor + cable loss - Amplifier Factor



Power	: AC 120V / 60Hz	Pol/Phase	: HORIZONTAL
Test Mode	: Mode 2, Band 1, CH36		:

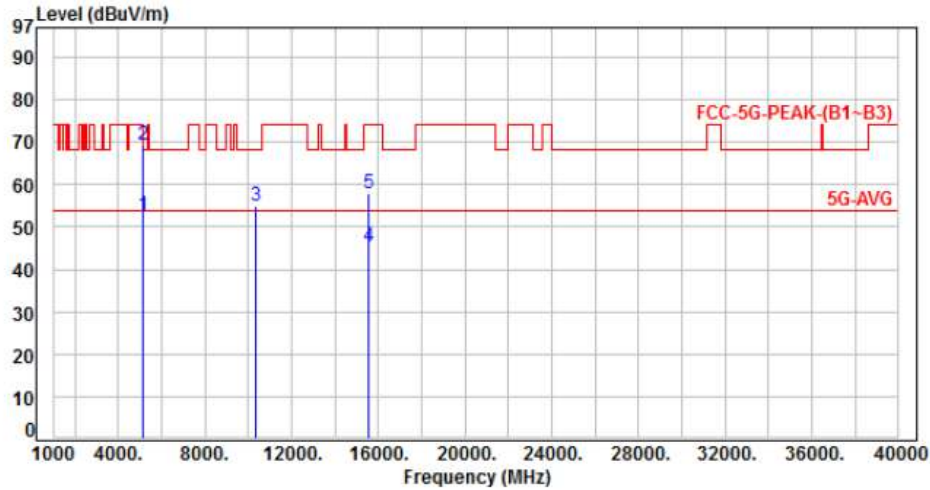

No.	Frequency (MHz)	Factor (dB)	Reading (dBuV)	Level (dBuV/m)	Limit (dBuV/m)	Margin (dB)	Detector	Height (cm)	Azimuth (deg)	P/F
1	5150.00	5.92	46.90	52.82	54.00	-1.18	Average	100	0	P
2	5150.00	5.92	63.52	69.44	74.00	-4.56	Peak	100	0	P
3	10360.00	12.95	41.85	54.80	68.20	-13.40	Peak	100	136	P
4	15540.00	15.69	29.68	45.37	54.00	-8.63	Average	100	83	P
5	15540.00	15.69	42.32	58.01	74.00	-15.99	Peak	100	83	P

Note: Level=Reading+Factor
Margin=Level-Limit
Factor=Antenna Factor + cable loss - Amplifier Factor



Power	: AC 120V / 60Hz	Pol/Phase	: VERTICAL
Test Mode	: Mode 2, Band 1, CH40		

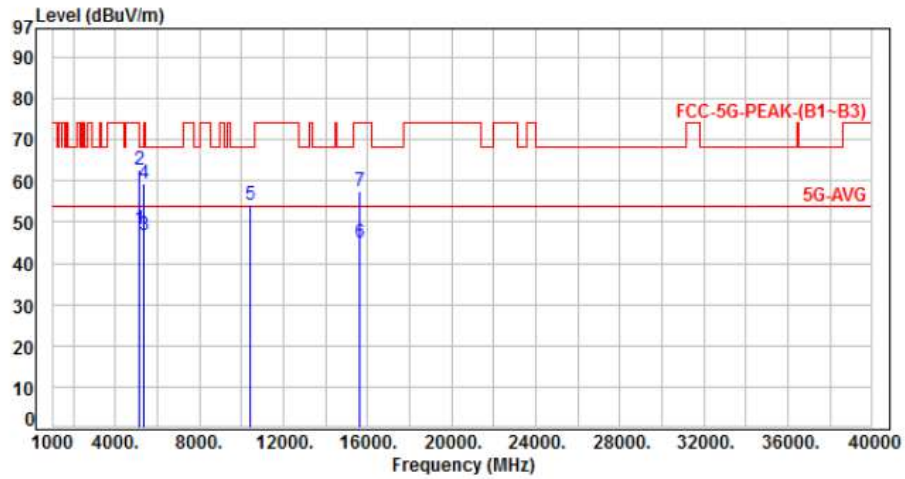

No.	Frequency (MHz)	Factor (dB)	Reading (dBUV)	Level (dBUV/m)	Limit (dBUV/m)	Margin (dB)	Detector	Height (cm)	Azimuth (deg)	P/F
1	5150.00	5.92	42.28	48.20	54.00	-5.80	Average	100	69	P
2	5150.00	5.92	56.60	62.52	74.00	-11.48	Peak	100	69	P
3	5350.00	6.22	40.74	46.96	54.00	-7.04	Average	100	69	P
4	5350.00	6.22	53.02	59.24	74.00	-14.76	Peak	100	69	P
5	10400.00	13.00	41.23	54.23	68.20	-13.97	Peak	100	104	P
6	15600.00	15.35	29.53	44.88	54.00	-9.12	Average	100	70	P
7	15600.00	15.35	42.28	57.63	74.00	-16.37	Peak	100	70	P

Note: Level=Reading+Factor
 Margin=Level-Limit
 Factor=Antenna Factor + cable loss - Amplifier Factor



Power	: AC 120V / 60Hz	Pol/Phase	: HORIZONTAL
Test Mode	: Mode 2, Band 1, CH40		:

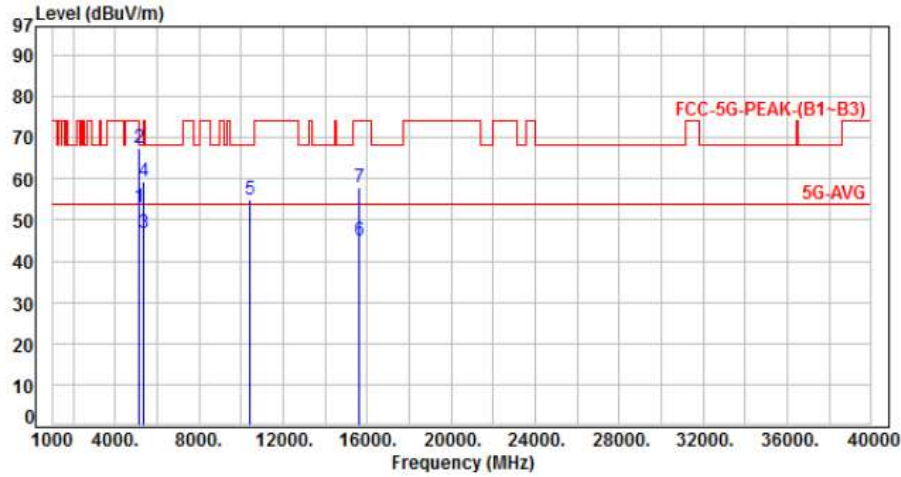

No.	Frequency (MHz)	Factor (dB)	Reading (dBuV)	Level (dBuV/m)	Limit (dBuV/m)	Margin (dB)	Detector	Height (cm)	Azimuth (deg)	P/F
1	5150.00	5.92	47.06	52.98	54.00	-1.02	Average	100	0	P
2	5150.00	5.92	61.40	67.32	74.00	-6.68	Peak	100	0	P
3	5350.00	6.22	40.77	46.99	54.00	-7.01	Average	100	0	P
4	5350.00	6.22	53.10	59.32	74.00	-14.68	Peak	100	0	P
5	10400.00	13.00	41.82	54.82	68.20	-13.38	Peak	100	117	P
6	15600.00	15.35	29.64	44.99	54.00	-9.01	Average	100	72	P
7	15600.00	15.35	42.58	57.93	74.00	-16.07	Peak	100	72	P

Note: Level=Reading+Factor
Margin=Level-Limit
Factor=Antenna Factor + cable loss - Amplifier Factor



Power	: AC 120V / 60Hz	Pol/Phase	: VERTICAL
Test Mode	: Mode 2, Band 1, CH48		:

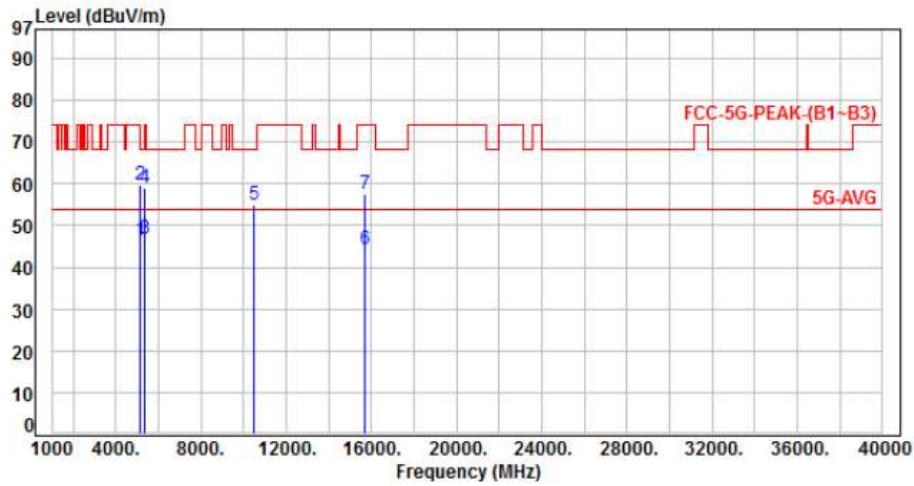

No.	Frequency (MHz)	Factor (dB)	Reading (dBUV)	Level (dBUV/m)	Limit (dBUV/m)	Margin (dB)	Detector	Height (cm)	Azimuth (deg)	P/F
1	5150.00	5.92	40.58	46.50	54.00	-7.50	Average	100	77	P
2	5150.00	5.92	53.74	59.66	74.00	-14.34	Peak	100	77	P
3	5350.00	6.22	40.76	46.98	54.00	-7.02	Average	100	77	P
4	5350.00	6.22	52.80	59.02	74.00	-14.98	Peak	100	77	P
5	10480.00	13.21	41.71	54.92	68.20	-13.28	Peak	100	110	P
6	15720.00	14.83	29.43	44.26	54.00	-9.74	Average	100	73	P
7	15720.00	14.83	42.85	57.68	74.00	-16.32	Peak	100	73	P

Note: Level=Reading+Factor
Margin=Level-Limit
Factor=Antenna Factor + cable loss - Amplifier Factor



Power	: AC 120V / 60Hz	Pol/Phase	: HORIZONTAL
Test Mode	: Mode 2, Band 1, CH48		:

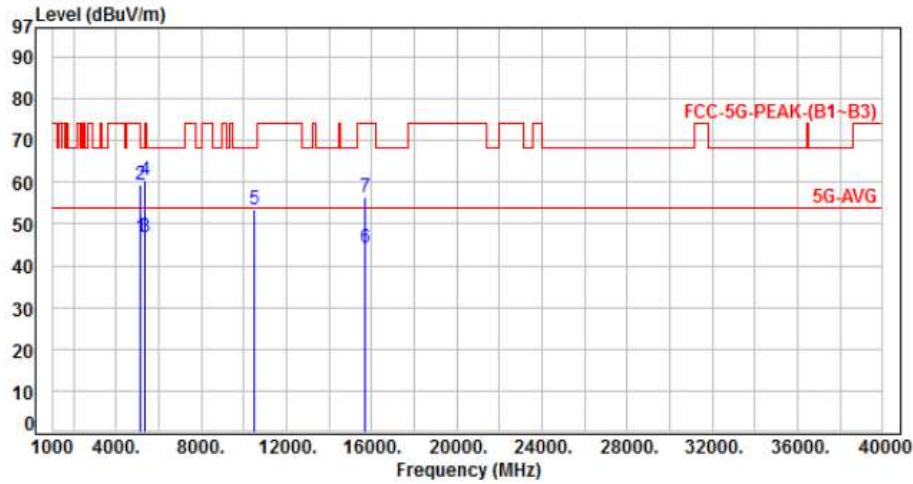

No.	Frequency (MHz)	Factor (dB)	Reading (dBuV)	Level (dBuV/m)	Limit (dBuV/m)	Margin (dB)	Detector	Height (cm)	Azimuth (deg)	P/F
1	5150.00	5.92	40.90	46.82	54.00	-7.18	Average	100	0	P
2	5150.00	5.92	53.30	59.22	74.00	-14.78	Peak	100	0	P
3	5350.00	6.22	40.69	46.91	54.00	-7.09	Average	100	0	P
4	5350.00	6.22	54.10	60.32	74.00	-13.68	Peak	100	0	P
5	10480.00	13.21	40.42	53.63	68.20	-14.57	Peak	100	113	P
6	15720.00	14.83	29.61	44.44	54.00	-9.56	Average	100	61	P
7	15720.00	14.83	41.55	56.38	74.00	-17.62	Peak	100	61	P

Note: Level=Reading+Factor
 Margin=Level-Limit
 Factor=Antenna Factor + cable loss - Amplifier Factor



Power	: AC 120V / 60Hz	Pol/Phase	: VERTICAL
Test Mode	: Mode 3, Band 1, CH38		:

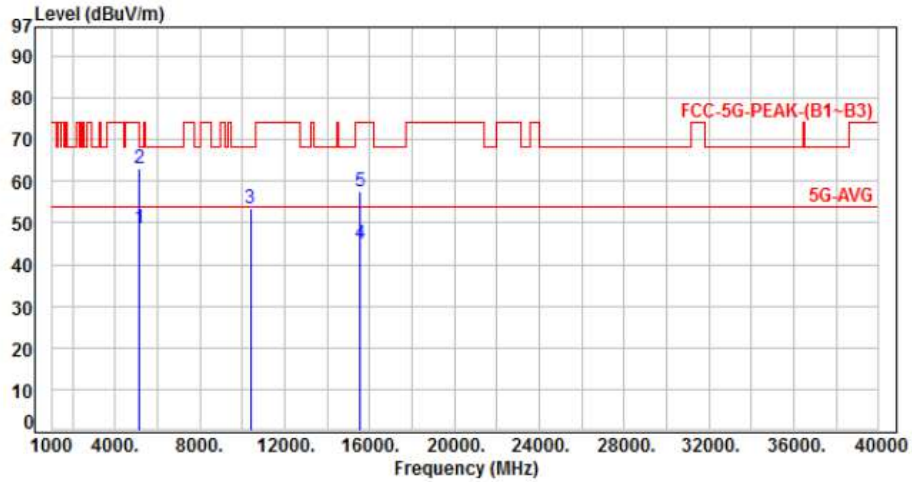

No.	Frequency (MHz)	Factor (dB)	Reading (dBuV)	Level (dBuV/m)	Limit (dBuV/m)	Margin (dB)	Detector	Height (cm)	Azimuth (deg)	P/F
1	5150.00	5.92	42.75	48.67	54.00	-5.33	Average	100	60	P
2	5150.00	5.92	57.00	62.92	74.00	-11.08	Peak	100	60	P
3	10380.00	12.97	40.47	53.44	68.20	-14.76	Peak	100	125	P
4	15570.00	15.52	29.42	44.94	54.00	-9.06	Average	100	119	P
5	15570.00	15.52	41.88	57.40	74.00	-16.60	Peak	100	119	P

Note: Level=Reading+Factor
 Margin=Level-Limit
 Factor=Antenna Factor + cable loss - Amplifier Factor



Power	: AC 120V / 60Hz	Pol/Phase	: HORIZONTAL
Test Mode	: Mode 3, Band 1, CH38		:

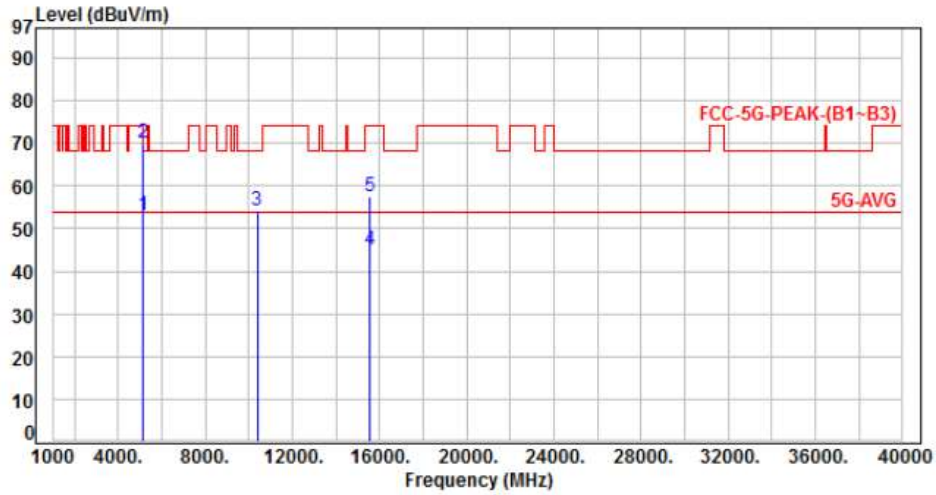

No.	Frequency (MHz)	Factor (dB)	Reading (dBuV)	Level (dBuV/m)	Limit (dBuV/m)	Margin (dB)	Detector	Height (cm)	Azimuth (deg)	P/F
1	5150.00	5.92	47.07	52.99	54.00	-1.01	Average	100	0	P
2	5150.00	5.92	64.08	70.00	74.00	-4.00	Peak	100	0	P
3	10380.00	12.97	41.42	54.39	68.20	-13.81	Peak	100	140	P
4	15570.00	15.52	29.59	45.11	54.00	-8.89	Average	100	88	P
5	15570.00	15.52	42.16	57.68	74.00	-16.32	Peak	100	88	P

Note: Level=Reading+Factor
Margin=Level-Limit
Factor=Antenna Factor + cable loss - Amplifier Factor



Power	: AC 120V / 60Hz	Pol/Phase	: VERTICAL
Test Mode	: Mode 3, Band 1, CH46		:

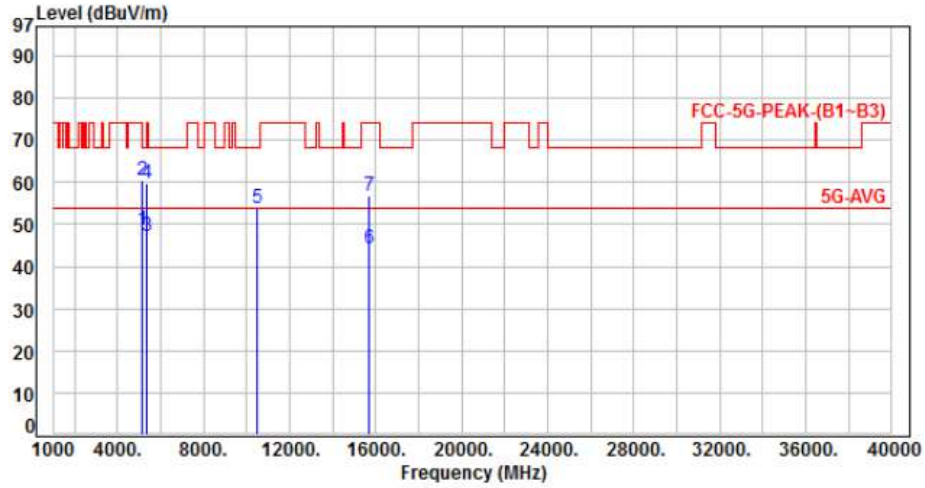

No.	Frequency (MHz)	Factor (dB)	Reading (dBuV)	Level (dBuV/m)	Limit (dBuV/m)	Margin (dB)	Detector	Height (cm)	Azimuth (deg)	P/F
1	5150.00	5.92	42.58	48.50	54.00	-5.50	Average	100	65	P
2	5150.00	5.92	54.52	60.44	74.00	-13.56	Peak	100	65	P
3	5350.00	6.22	41.05	47.27	54.00	-6.73	Average	100	65	P
4	5350.00	6.22	53.53	59.75	74.00	-14.25	Peak	100	65	P
5	10460.00	13.16	40.82	53.98	68.20	-14.22	Peak	100	105	P
6	15690.00	14.84	29.51	44.35	54.00	-9.65	Average	100	76	P
7	15690.00	14.84	41.88	56.72	74.00	-17.28	Peak	100	76	P

Note: Level=Reading+Factor
 Margin=Level-Limit
 Factor=Antenna Factor + cable loss - Amplifier Factor



Power	: AC 120V / 60Hz	Pol/Phase	: HORIZONTAL
Test Mode	: Mode 3, Band 1, CH46		:

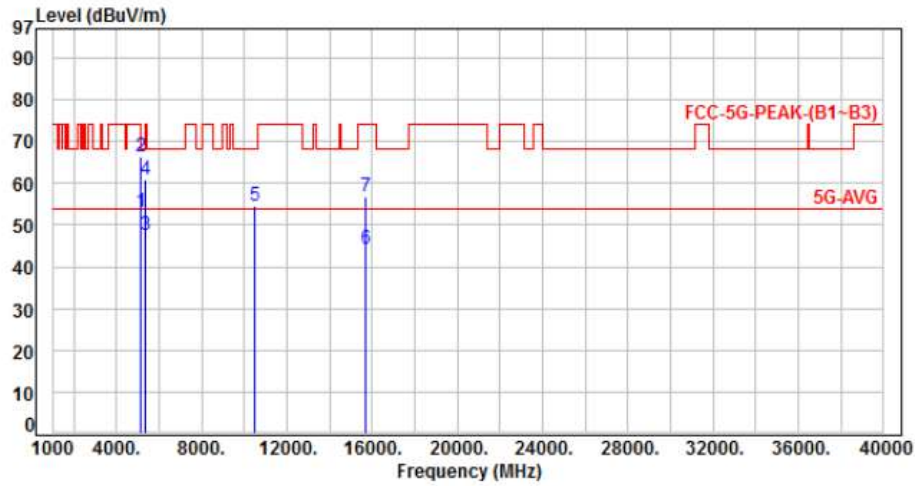

No.	Frequency (MHz)	Factor (dB)	Reading (dBuV)	Level (dBuV/m)	Limit (dBuV/m)	Margin (dB)	Detector	Height (cm)	Azimuth (deg)	P/F
1	5150.00	5.92	47.07	52.99	54.00	-1.01	Average	100	0	P
2	5150.00	5.92	60.40	66.32	74.00	-7.68	Peak	100	0	P
3	5350.00	6.22	41.50	47.72	54.00	-6.28	Average	100	0	P
4	5350.00	6.22	54.50	60.72	74.00	-13.28	Peak	100	0	P
5	10460.00	13.16	41.38	54.54	68.20	-13.66	Peak	100	115	P
6	15690.00	14.84	29.52	44.36	54.00	-9.64	Average	100	69	P
7	15690.00	14.84	42.13	56.97	74.00	-17.03	Peak	100	69	P

Note: Level=Reading+Factor
 Margin=Level-Limit
 Factor=Antenna Factor + cable loss - Amplifier Factor



Power	: AC 120V / 60Hz	Pol/Phase	: VERTICAL
Test Mode	: Mode 4, Band 1, CH42		:

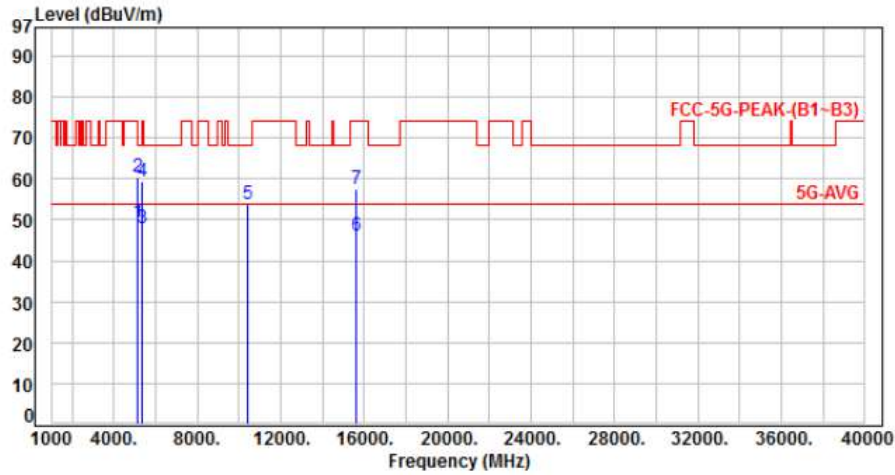

No.	Frequency (MHz)	Factor (dB)	Reading (dBuV)	Level (dBuV/m)	Limit (dBuV/m)	Margin (dB)	Detector	Height (cm)	Azimuth (deg)	P/F
1	5150.00	5.92	43.38	49.30	54.00	-4.70	Average	100	63	P
2	5150.00	5.92	54.45	60.37	74.00	-13.63	Peak	100	63	P
3	5350.00	6.22	41.57	47.79	54.00	-6.21	Average	100	63	P
4	5350.00	6.22	53.08	59.30	74.00	-14.70	Peak	100	63	P
5	10420.00	13.06	40.88	53.94	68.20	-14.26	Peak	100	111	P
6	15630.00	15.18	30.86	46.04	54.00	-7.96	Average	100	62	P
7	15630.00	15.18	42.40	57.58	74.00	-16.42	Peak	100	62	P

Note: Level=Reading+Factor
 Margin=Level-Limit
 Factor=Antenna Factor + cable loss - Amplifier Factor



Power	: AC 120V / 60Hz	Pol/Phase	: HORIZONTAL
Test Mode	: Mode 4, Band 1, CH42		:

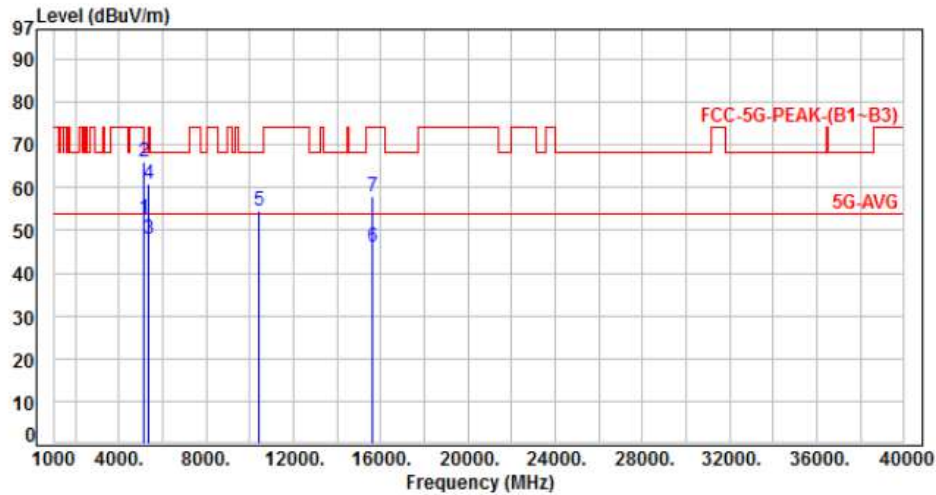

No.	Frequency (MHz)	Factor (dB)	Reading (dBuV)	Level (dBuV/m)	Limit (dBuV/m)	Margin (dB)	Detector	Height (cm)	Azimuth (deg)	P/F
1	5150.00	5.92	47.00	52.92	54.00	-1.08	Average	100	0	P
2	5150.00	5.92	60.03	65.95	74.00	-8.05	Peak	100	0	P
3	5350.00	6.22	41.67	47.89	54.00	-6.11	Average	100	0	P
4	5350.00	6.22	54.50	60.72	74.00	-13.28	Peak	100	0	P
5	10420.00	13.06	41.60	54.66	68.20	-13.54	Peak	100	72	P
6	15630.00	15.18	31.03	46.21	54.00	-7.79	Average	100	85	P
7	15630.00	15.18	42.56	57.74	74.00	-16.26	Peak	100	85	P

Note: Level=Reading+Factor
 Margin=Level-Limit
 Factor=Antenna Factor + cable loss - Amplifier Factor



Power	: AC 120V / 60Hz	Pol/Phase	: VERTICAL
Test Mode	: Mode 1, Band 2, CH52		:

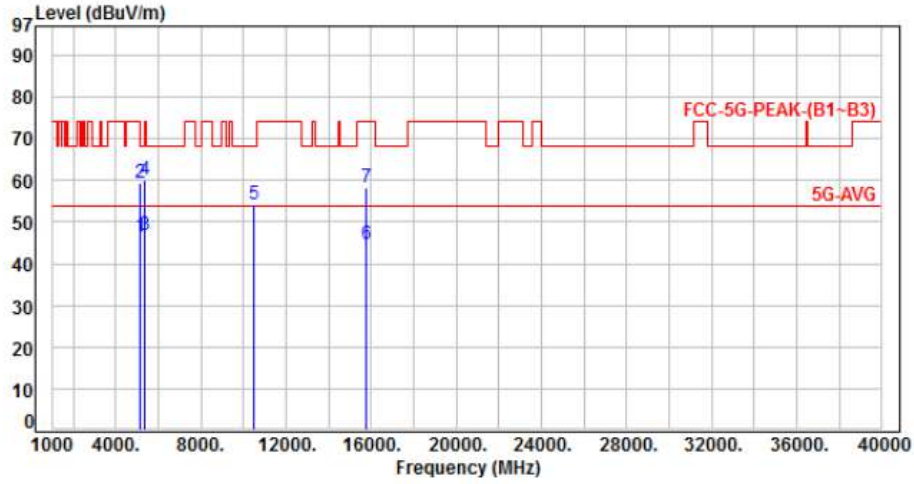

No.	Frequency (MHz)	Factor (dB)	Reading (dBuV)	Level (dBuV/m)	Limit (dBuV/m)	Margin (dB)	Detector	Height (cm)	Azimuth (deg)	P/F
1	5150.00	5.92	40.59	46.51	54.00	-7.49	Average	100	59	P
2	5150.00	5.92	53.49	59.41	74.00	-14.59	Peak	100	59	P
3	5350.00	6.22	40.45	46.67	54.00	-7.33	Average	100	59	P
4	5350.00	6.22	54.01	60.23	74.00	-13.77	Peak	100	59	P
5	10520.00	13.30	41.00	54.30	68.20	-13.90	Peak	100	100	P
6	15780.00	14.97	29.66	44.63	54.00	-9.37	Average	100	166	P
7	15780.00	14.97	43.35	58.32	74.00	-15.68	Peak	100	166	P

Note: Level=Reading+Factor
Margin=Level-Limit
Factor=Antenna Factor + cable loss - Amplifier Factor



Power	: AC 120V / 60Hz	Pol/Phase	: HORIZONTAL
Test Mode	: Mode 1, Band 2, CH52		:

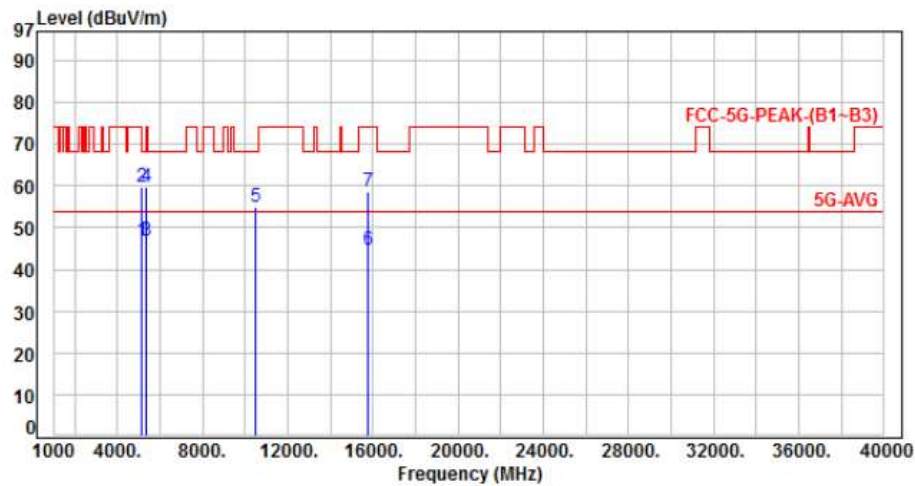

No.	Frequency (MHz)	Factor (dB)	Reading (dBuV)	Level (dBuV/m)	Limit (dBuV/m)	Margin (dB)	Detector	Height (cm)	Azimuth (deg)	P/F
1	5150.00	5.92	41.01	46.93	54.00	-7.07	Average	100	254	P
2	5150.00	5.92	53.83	59.75	74.00	-14.25	Peak	100	254	P
3	5350.00	6.22	40.54	46.76	54.00	-7.24	Average	100	254	P
4	5350.00	6.22	53.70	59.92	74.00	-14.08	Peak	100	254	P
5	10520.00	13.30	41.83	55.13	68.20	-13.07	Peak	100	134	P
6	15780.00	14.97	29.67	44.64	54.00	-9.36	Average	100	83	P
7	15780.00	14.97	43.83	58.80	74.00	-15.20	Peak	100	83	P

Note: Level=Reading+Factor
 Margin=Level-Limit
 Factor=Antenna Factor + cable loss - Amplifier Factor



Power	: AC 120V / 60Hz	Pol/Phase	: VERTICAL
Test Mode	: Mode 1, Band 2, CH60		:

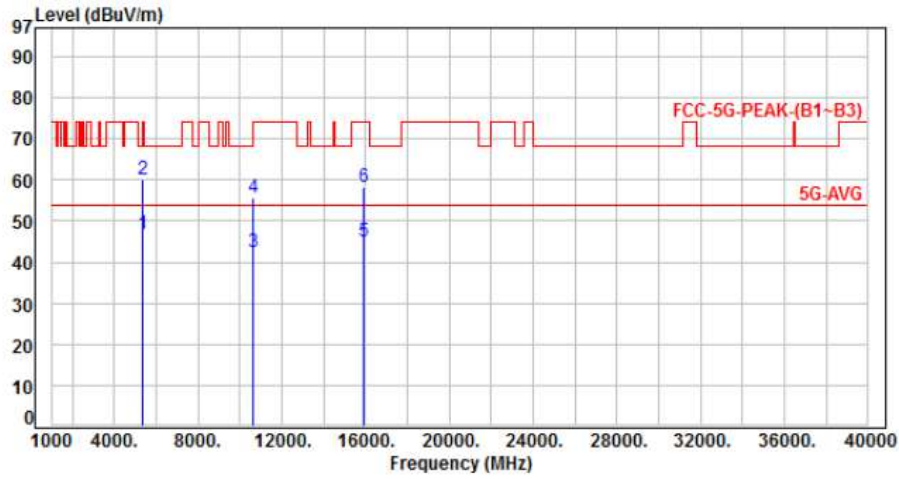

No.	Frequency (MHz)	Factor (dB)	Reading (dBuV)	Level (dBuV/m)	Limit (dBuV/m)	Margin (dB)	Detector	Height (cm)	Azimuth (deg)	P/F
1	5350.00	6.22	40.76	46.98	54.00	-7.02	Average	100	176	P
2	5350.00	6.22	53.87	60.09	74.00	-13.91	Peak	100	176	P
3	10600.00	13.47	29.01	42.48	54.00	-11.52	Average	100	101	P
4	10600.00	13.47	42.29	55.76	74.00	-18.24	Peak	100	101	P
5	15900.00	14.95	29.94	44.89	54.00	-9.11	Average	100	247	P
6	15900.00	14.95	43.47	58.42	74.00	-15.58	Peak	100	247	P

Note: Level=Reading+Factor
 Margin=Level-Limit
 Factor=Antenna Factor + cable loss - Amplifier Factor



Power	: AC 120V / 60Hz	Pol/Phase	: HORIZONTAL
Test Mode	: Mode 1, Band 2, CH60		:

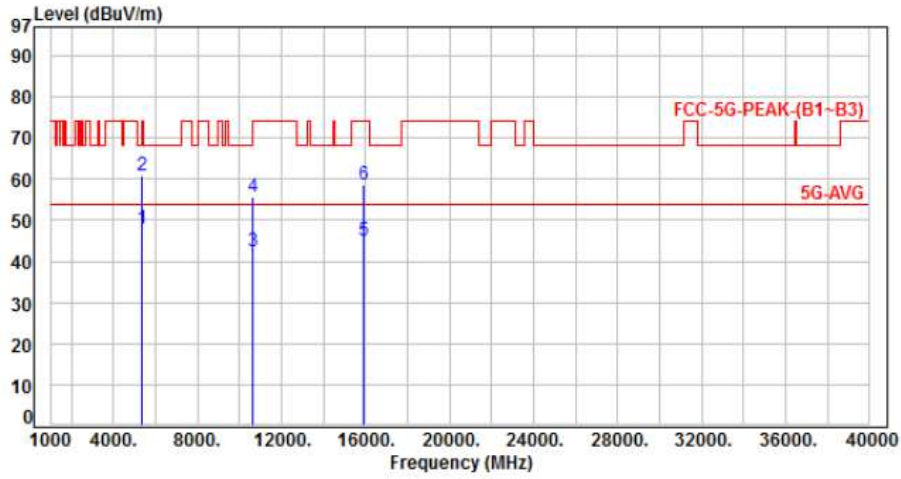

No.	Frequency (MHz)	Factor (dB)	Reading (dBuV)	Level (dBuV/m)	Limit (dBuV/m)	Margin (dB)	Detector	Height (cm)	Azimuth (deg)	P/F
1	5350.00	6.22	41.61	47.83	54.00	-6.17	Average	100	258	P
2	5350.00	6.22	54.54	60.76	74.00	-13.24	Peak	100	258	P
3	10600.00	13.47	28.80	42.27	54.00	-11.73	Average	100	12	P
4	10600.00	13.47	42.12	55.59	74.00	-18.41	Peak	100	12	P
5	15900.00	14.95	30.16	45.11	54.00	-8.89	Average	100	116	P
6	15900.00	14.95	43.82	58.77	74.00	-15.23	Peak	100	116	P

Note: Level=Reading+Factor
 Margin=Level-Limit
 Factor=Antenna Factor + cable loss - Amplifier Factor



Power	: AC 120V / 60Hz	Pol/Phase	: VERTICAL
Test Mode	: Mode 1, Band 2, CH64		:

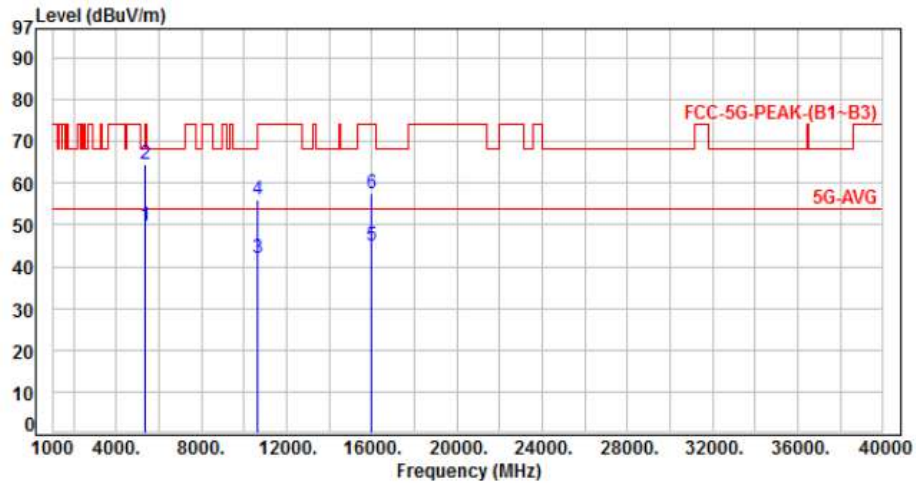

No.	Frequency (MHz)	Factor (dB)	Reading (dBuV)	Level (dBuV/m)	Limit (dBuV/m)	Margin (dB)	Detector	Height (cm)	Azimuth (deg)	P/F
1	5350.00	6.22	43.43	49.65	54.00	-4.35	Average	100	70	P
2	5350.00	6.22	58.45	64.67	74.00	-9.33	Peak	100	70	P
3	10640.00	13.52	28.70	42.22	54.00	-11.78	Average	100	71	P
4	10640.00	13.52	42.70	56.22	74.00	-17.78	Peak	100	71	P
5	15960.00	14.67	30.44	45.11	54.00	-8.89	Average	100	144	P
6	15960.00	14.67	42.90	57.57	74.00	-16.43	Peak	100	144	P

Note: Level=Reading+Factor
 Margin=Level-Limit
 Factor=Antenna Factor + cable loss - Amplifier Factor



Power	: AC 120V / 60Hz	Pol/Phase	: HORIZONTAL
Test Mode	: Mode 1, Band 2, CH64		:

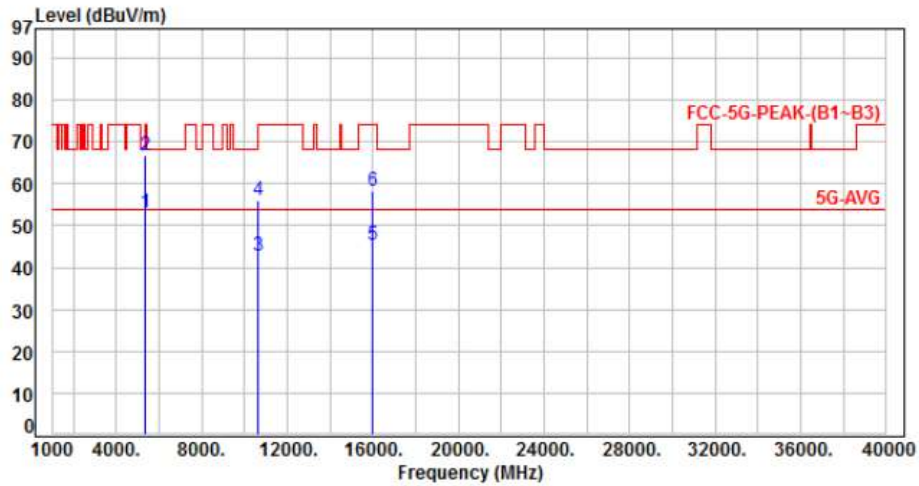

No.	Frequency (MHz)	Factor (dB)	Reading (dBuV)	Level (dBuV/m)	Limit (dBuV/m)	Margin (dB)	Detector	Height (cm)	Azimuth (deg)	P/F
1	5350.00	6.22	46.77	52.99	54.00	-1.01	Average	100	25	P
2	5350.00	6.22	60.62	66.84	74.00	-7.16	Peak	100	25	P
3	10640.00	13.52	29.43	42.95	54.00	-11.05	Average	100	44	P
4	10640.00	13.52	42.62	56.14	74.00	-17.86	Peak	100	44	P
5	15960.00	14.67	30.59	45.26	54.00	-8.74	Average	100	264	P
6	15960.00	14.67	43.64	58.31	74.00	-15.69	Peak	100	264	P

Note: Level=Reading+Factor
 Margin=Level-Limit
 Factor=Antenna Factor + cable loss - Amplifier Factor



Power	: AC 120V / 60Hz	Pol/Phase	: VERTICAL
Test Mode	: Mode 2, Band 2, CH52		:

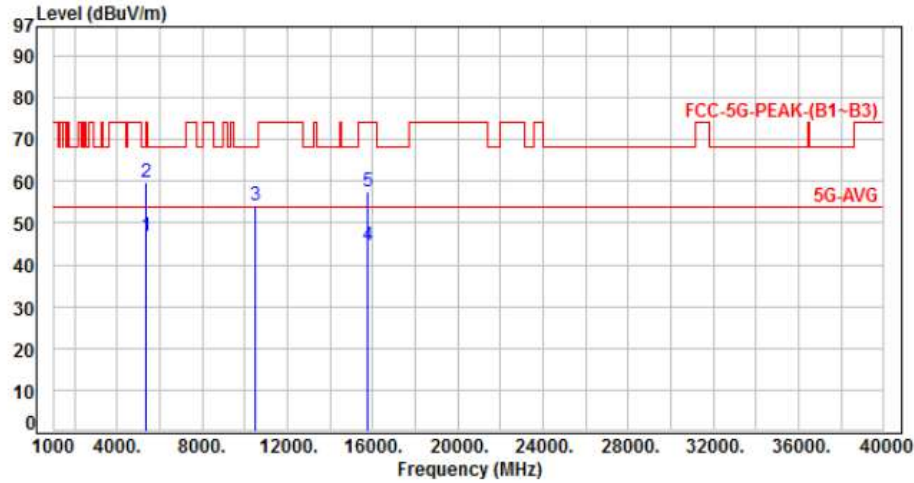

No.	Frequency (MHz)	Factor (dB)	Reading (dBuV)	Level (dBuV/m)	Limit (dBuV/m)	Margin (dB)	Detector	Height (cm)	Azimuth (deg)	P/F
1	5350.00	6.22	40.62	46.84	54.00	-7.16	Average	100	65	P
2	5350.00	6.22	53.57	59.79	74.00	-14.21	Peak	100	65	P
3	10520.00	13.30	41.00	54.30	68.20	-13.90	Peak	100	7	P
4	15780.00	14.97	29.73	44.70	54.00	-9.30	Average	100	66	P
5	15780.00	14.97	42.66	57.63	74.00	-16.37	Peak	100	66	P

Note: Level=Reading+Factor
Margin=Level-Limit
Factor=Antenna Factor + cable loss - Amplifier Factor



Power	: AC 120V / 60Hz	Pol/Phase	: HORIZONTAL
Test Mode	: Mode 2, Band 2, CH52		:

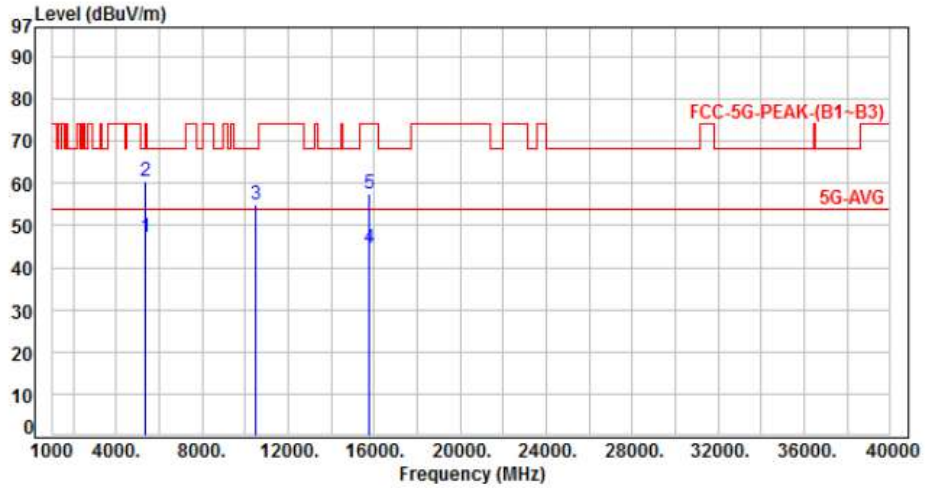

No.	Frequency (MHz)	Factor (dB)	Reading (dBUV)	Level (dBUV/m)	Limit (dBUV/m)	Margin (dB)	Detector	Height (cm)	Azimuth (deg)	P/F
1	5350.00	6.22	40.89	47.11	54.00	-6.89	Average	100	336	P
2	5350.00	6.22	54.13	60.35	74.00	-13.65	Peak	100	336	P
3	10520.00	13.30	41.60	54.90	68.20	-13.30	Peak	100	60	P
4	15780.00	14.97	29.76	44.73	54.00	-9.27	Average	100	176	P
5	15780.00	14.97	42.62	57.59	74.00	-16.41	Peak	100	176	P

Note: Level=Reading+Factor
 Margin=Level-Limit
 Factor=Antenna Factor + cable loss - Amplifier Factor



Power	: AC 120V / 60Hz	Pol/Phase	: VERTICAL
Test Mode	: Mode 2, Band 2, CH60		

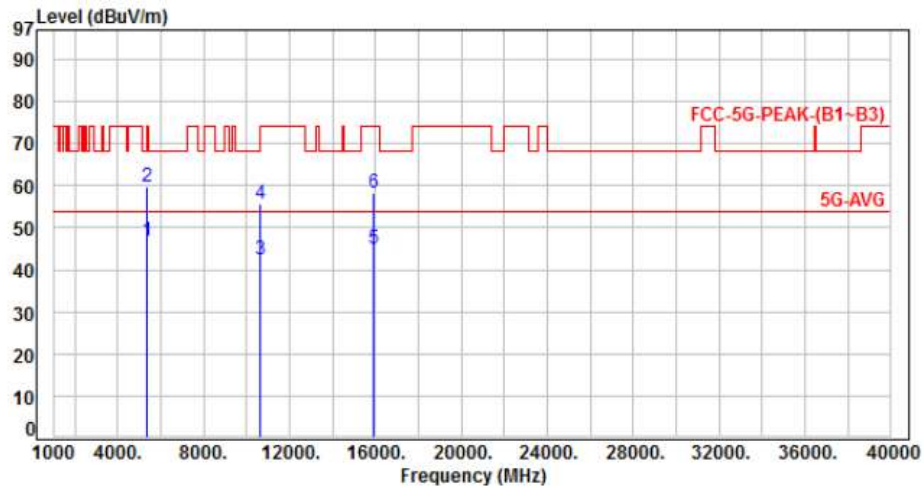

No.	Frequency (MHz)	Factor (dB)	Reading (dBuV)	Level (dBuV/m)	Limit (dBuV/m)	Margin (dB)	Detector	Height (cm)	Azimuth (deg)	P/F
1	5350.00	6.22	40.64	46.86	54.00	-7.14	Average	100	164	P
2	5350.00	6.22	53.66	59.88	74.00	-14.12	Peak	100	164	P
3	10600.00	13.47	28.89	42.36	54.00	-11.64	Average	100	189	P
4	10600.00	13.47	42.34	55.81	74.00	-18.19	Peak	100	189	P
5	15900.00	14.95	30.17	45.12	54.00	-8.88	Average	100	29	P
6	15900.00	14.95	43.29	58.24	74.00	-15.76	Peak	100	29	P

Note: Level=Reading+Factor
 Margin=Level-Limit
 Factor=Antenna Factor + cable loss - Amplifier Factor



Power	: AC 120V / 60Hz	Pol/Phase	: HORIZONTAL
Test Mode	: Mode 2, Band 2, CH60		:

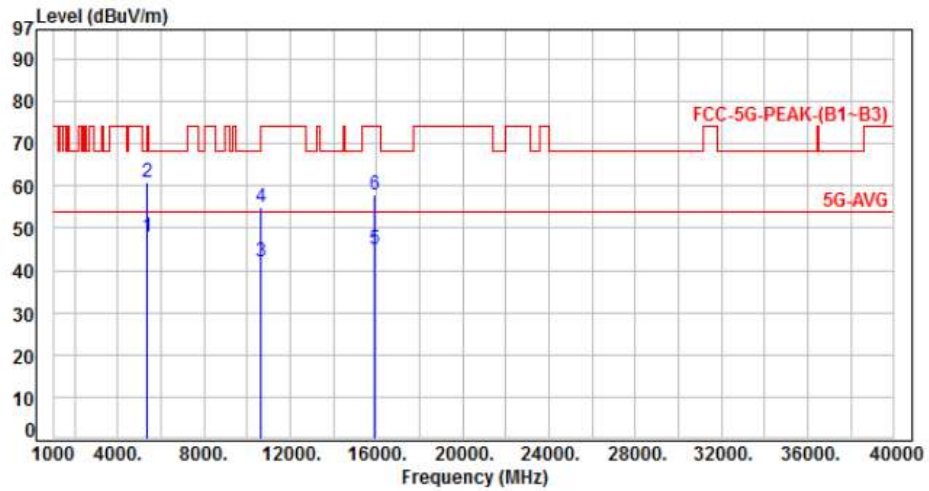

No.	Frequency (MHz)	Factor (dB)	Reading (dBuV)	Level (dBuV/m)	Limit (dBuV/m)	Margin (dB)	Detector	Height (cm)	Azimuth (deg)	P/F
1	5350.00	6.22	41.59	47.81	54.00	-6.19	Average	100	59	P
2	5350.00	6.22	54.57	60.79	74.00	-13.21	Peak	100	59	P
3	10600.00	13.47	28.50	41.97	54.00	-12.03	Average	100	43	P
4	10600.00	13.47	41.43	54.90	74.00	-19.10	Peak	100	43	P
5	15900.00	14.95	30.12	45.07	54.00	-8.93	Average	100	112	P
6	15900.00	14.95	42.81	57.76	74.00	-16.24	Peak	100	112	P

Note: Level=Reading+Factor
 Margin=Level-Limit
 Factor=Antenna Factor + cable loss - Amplifier Factor



Power	: AC 120V / 60Hz	Pol/Phase	: VERTICAL
Test Mode	: Mode 2, Band 2, CH64		:

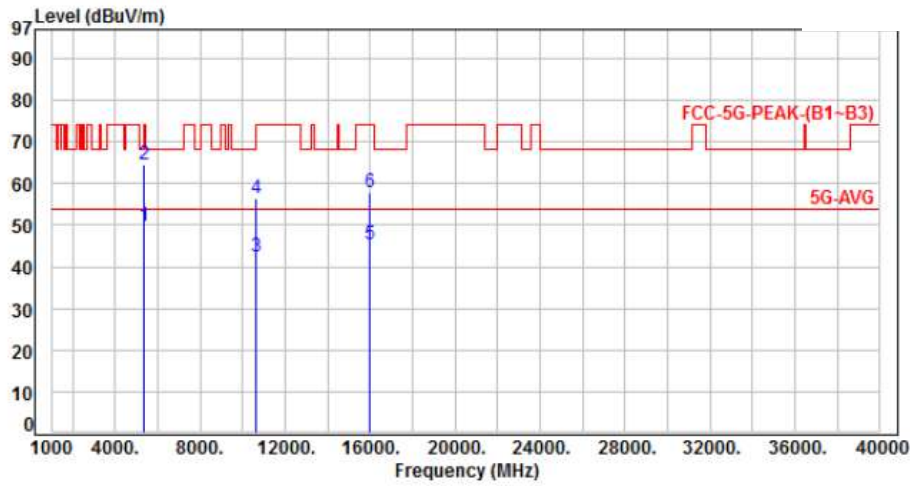

No.	Frequency (MHz)	Factor (dB)	Reading (dBuV)	Level (dBuV/m)	Limit (dBuV/m)	Margin (dB)	Detector	Height (cm)	Azimuth (deg)	P/F
1	5350.00	6.22	43.56	49.78	54.00	-4.22	Average	100	70	P
2	5350.00	6.22	58.24	64.46	74.00	-9.54	Peak	100	70	P
3	10640.00	13.52	28.82	42.34	54.00	-11.66	Average	100	83	P
4	10640.00	13.52	42.80	56.32	74.00	-17.68	Peak	100	83	P
5	15960.00	14.67	30.56	45.23	54.00	-8.77	Average	100	242	P
6	15960.00	14.67	43.42	58.09	74.00	-15.91	Peak	100	242	P

Note: Level=Reading+Factor
 Margin=Level-Limit
 Factor=Antenna Factor + cable loss - Amplifier Factor



Power	: AC 120V / 60Hz	Pol/Phase	: HORIZONTAL
Test Mode	: Mode 2, Band 2, CH64		:

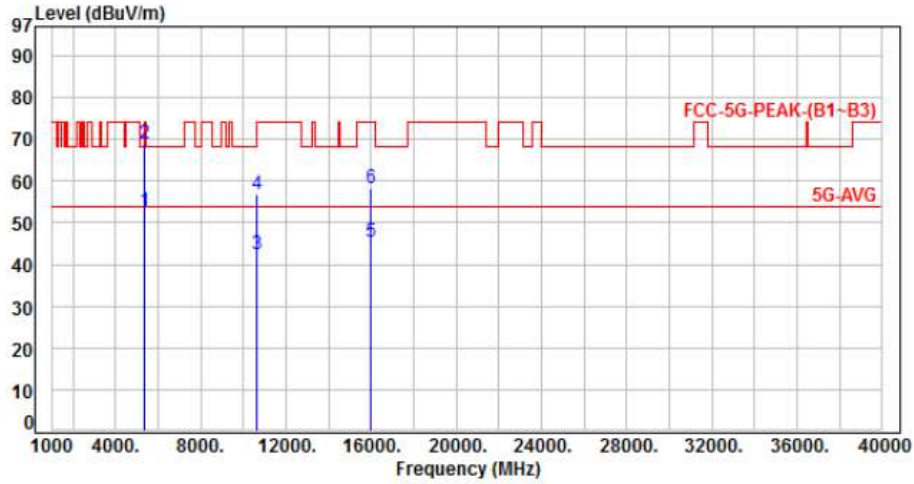

No.	Frequency (MHz)	Factor (dB)	Reading (dBuV)	Level (dBuV/m)	Limit (dBuV/m)	Margin (dB)	Detector	Height (cm)	Azimuth (deg)	P/F
1	5350.00	6.22	46.65	52.87	54.00	-1.13	Average	100	30	P
2	5350.00	6.22	62.59	68.81	74.00	-5.19	Peak	100	30	P
3	10640.00	13.52	28.97	42.49	54.00	-11.51	Average	100	145	P
4	10640.00	13.52	43.44	56.96	74.00	-17.04	Peak	100	145	P
5	15960.00	14.67	30.71	45.38	54.00	-8.62	Average	100	330	P
6	15960.00	14.67	43.55	58.22	74.00	-15.78	Peak	100	330	P

Note: Level=Reading+Factor
Margin=Level-Limit
Factor=Antenna Factor + cable loss - Amplifier Factor



Power	: AC 120V / 60Hz	Pol/Phase	: VERTICAL
Test Mode	: Mode 3, Band 2, CH54		:

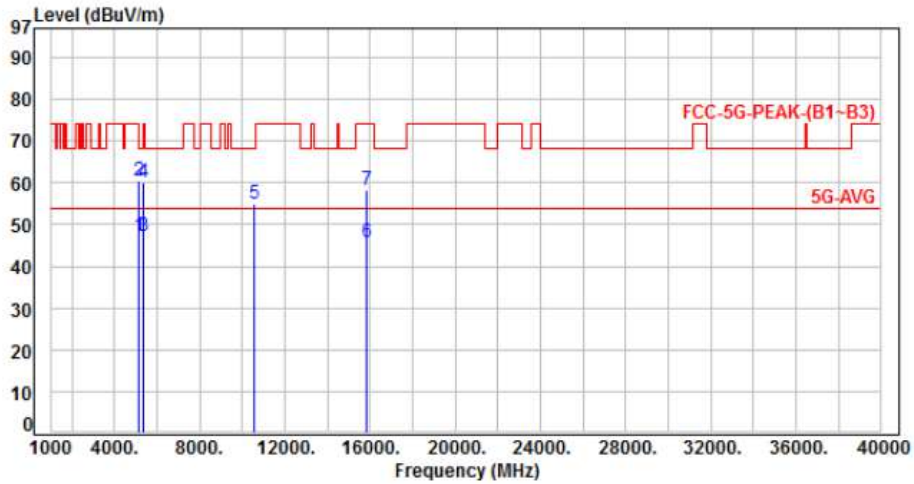

No.	Frequency (MHz)	Factor (dB)	Reading (dBuV)	Level (dBuV/m)	Limit (dBuV/m)	Margin (dB)	Detector	Height (cm)	Azimuth (deg)	P/F
1	5150.00	5.92	41.19	47.11	54.00	-6.89	Average	100	75	P
2	5150.00	5.92	54.38	60.30	74.00	-13.70	Peak	100	75	P
3	5350.00	6.22	41.01	47.23	54.00	-6.77	Average	100	75	P
4	5350.00	6.22	53.81	60.03	74.00	-13.97	Peak	100	75	P
5	10540.00	13.34	41.62	54.96	68.20	-13.24	Peak	100	62	P
6	15810.00	15.01	30.66	45.67	54.00	-8.33	Average	100	166	P
7	15810.00	15.01	43.13	58.14	74.00	-15.86	Peak	100	166	P

Note: Level=Reading+Factor
Margin=Level-Limit
Factor=Antenna Factor + cable loss - Amplifier Factor



Power	: AC 120V / 60Hz	Pol/Phase	: HORIZONTAL
Test Mode	: Mode 3, Band 2, CH54		:

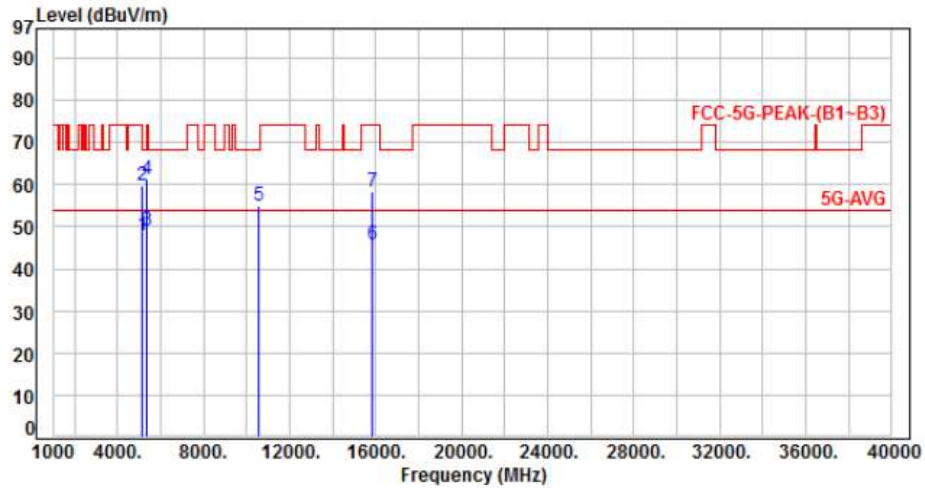

No.	Frequency (MHz)	Factor (dB)	Reading (dBuV)	Level (dBuV/m)	Limit (dBuV/m)	Margin (dB)	Detector	Height (cm)	Azimuth (deg)	P/F
1	5150.00	5.92	41.87	47.79	54.00	-6.21	Average	100	355	P
2	5150.00	5.92	53.92	59.84	74.00	-14.16	Peak	100	355	P
3	5350.00	6.22	42.78	49.00	54.00	-5.00	Average	100	355	P
4	5350.00	6.22	54.94	61.16	74.00	-12.84	Peak	100	355	P
5	10540.00	13.34	41.44	54.78	68.20	-13.42	Peak	100	83	P
6	15810.00	15.01	30.71	45.72	54.00	-8.28	Average	100	118	P
7	15810.00	15.01	43.18	58.19	74.00	-15.81	Peak	100	118	P

Note: Level=Reading+Factor
 Margin=Level-Limit
 Factor=Antenna Factor + cable loss - Amplifier Factor



Power	: AC 120V / 60Hz	Pol/Phase	: VERTICAL
Test Mode	: Mode 3, Band 2, CH62		:

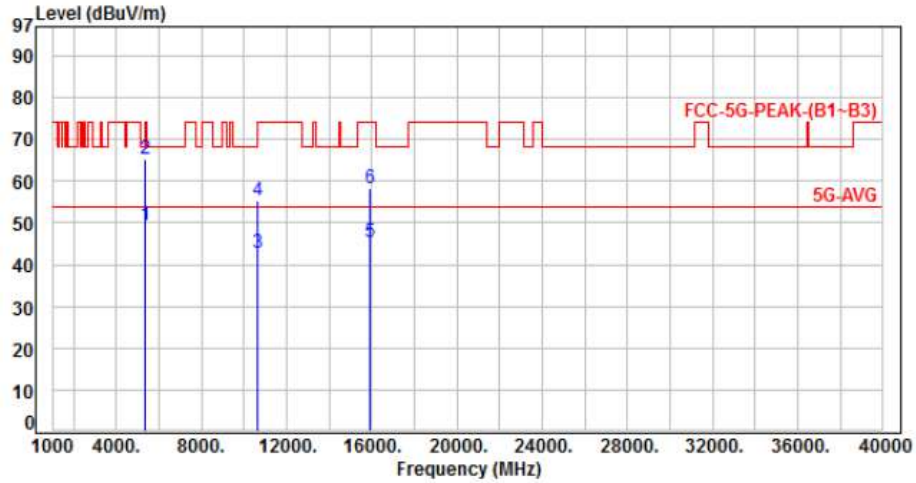

No.	Frequency (MHz)	Factor (dB)	Reading (dBuV)	Level (dBuV/m)	Limit (dBuV/m)	Margin (dB)	Detector	Height (cm)	Azimuth (deg)	P/F
1	5350.00	6.22	43.23	49.45	54.00	-4.55	Average	100	70	P
2	5350.00	6.22	59.07	65.29	74.00	-8.71	Peak	100	70	P
3	10620.00	13.49	29.35	42.84	54.00	-11.16	Average	100	35	P
4	10620.00	13.49	41.80	55.29	74.00	-18.71	Peak	100	35	P
5	15930.00	14.81	30.68	45.49	54.00	-8.51	Average	100	129	P
6	15930.00	14.81	43.29	58.10	74.00	-15.90	Peak	100	129	P

Note: Level=Reading+Factor
 Margin=Level-Limit
 Factor=Antenna Factor + cable loss - Amplifier Factor



Power	: AC 120V / 60Hz	Pol/Phase	: HORIZONTAL
Test Mode	: Mode 3, Band 2, CH62		:

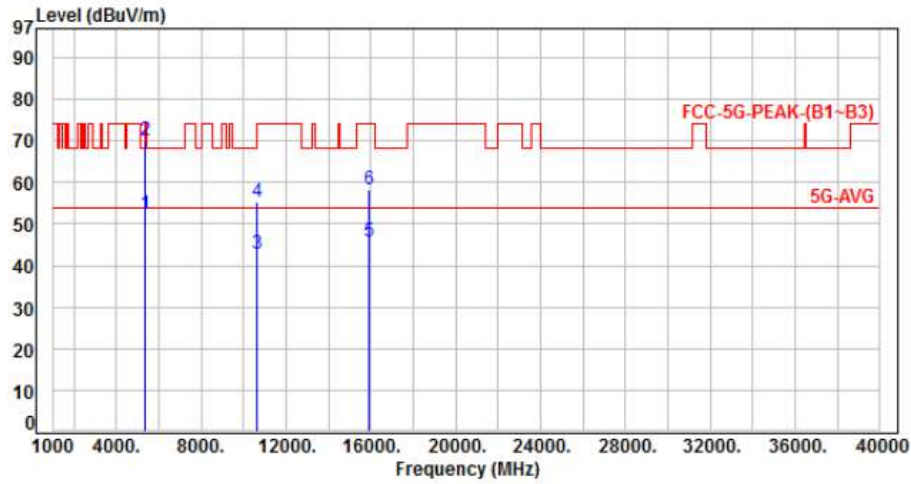

No.	Frequency (MHz)	Factor (dB)	Reading (dBuV)	Level (dBuV/m)	Limit (dBuV/m)	Margin (dB)	Detector	Height (cm)	Azimuth (deg)	P/F
1	5350.00	6.22	46.26	52.48	54.00	-1.52	Average	100	350	P
2	5350.00	6.22	63.95	70.17	74.00	-3.83	Peak	100	350	P
3	10620.00	13.49	29.33	42.82	54.00	-11.18	Average	100	11	P
4	10620.00	13.49	42.01	55.50	74.00	-18.50	Peak	100	11	P
5	15930.00	14.81	30.98	45.79	54.00	-8.21	Average	100	330	P
6	15930.00	14.81	43.59	58.40	74.00	-15.60	Peak	100	330	P

Note: Level=Reading+Factor
 Margin=Level-Limit
 Factor=Antenna Factor + cable loss - Amplifier Factor



Power	: AC 120V / 60Hz	Pol/Phase	: VERTICAL
Test Mode	: Mode 4, Band 2, CH58		:

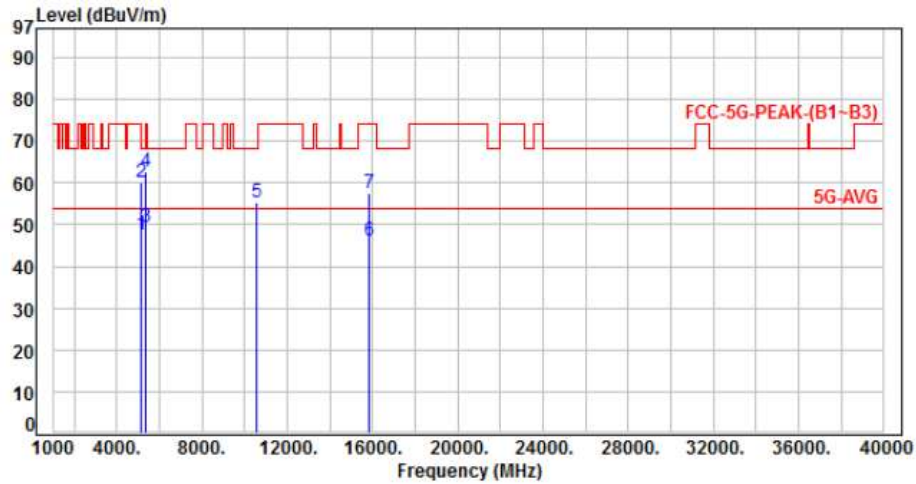

No.	Frequency (MHz)	Factor (dB)	Reading (dBuV)	Level (dBuV/m)	Limit (dBuV/m)	Margin (dB)	Detector	Height (cm)	Azimuth (deg)	P/F
1	5150.00	5.92	41.82	47.74	54.00	-6.26	Average	100	75	P
2	5150.00	5.92	54.37	60.29	74.00	-13.71	Peak	100	75	P
3	5350.00	6.22	43.31	49.53	54.00	-4.47	Average	100	75	P
4	5350.00	6.22	56.50	62.72	74.00	-11.28	Peak	100	75	P
5	10580.00	13.42	41.78	55.20	68.20	-13.00	Peak	100	89	P
6	15870.00	14.97	31.25	46.22	54.00	-7.78	Average	100	174	P
7	15870.00	14.97	42.74	57.71	74.00	-16.29	Peak	100	174	P

Note: Level=Reading+Factor
 Margin=Level-Limit
 Factor=Antenna Factor + cable loss - Amplifier Factor



Power	: AC 120V / 60Hz	Pol/Phase	: HORIZONTAL
Test Mode	: Mode 4, Band 2, CH58		:

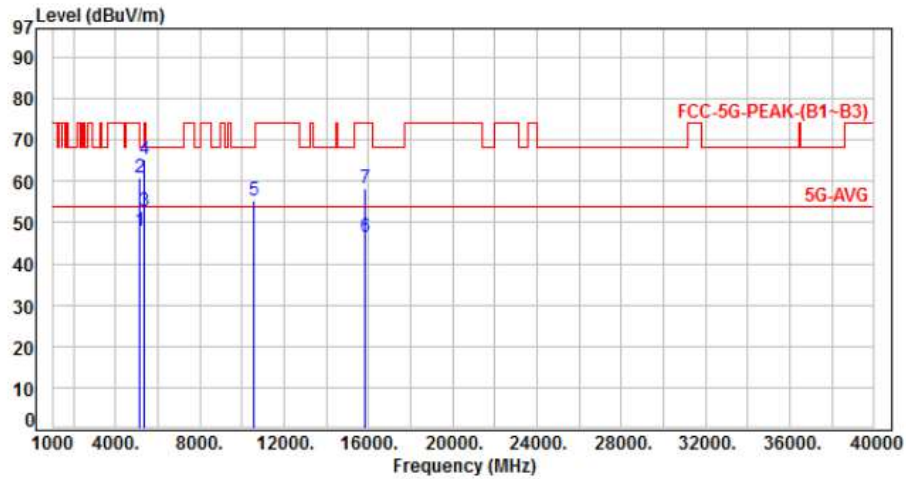

No.	Frequency (MHz)	Factor (dB)	Reading (dBuV)	Level (dBuV/m)	Limit (dBuV/m)	Margin (dB)	Detector	Height (cm)	Azimuth (deg)	P/F
1	5150.00	5.92	41.97	47.89	54.00	-6.11	Average	100	355	P
2	5150.00	5.92	55.03	60.95	74.00	-13.05	Peak	100	355	P
3	5350.00	6.22	46.58	52.80	54.00	-1.20	Average	100	355	P
4	5350.00	6.22	59.06	65.28	74.00	-8.72	Peak	100	355	P
5	10580.00	13.42	41.90	55.32	68.20	-12.88	Peak	100	163	P
6	15870.00	14.97	31.67	46.64	54.00	-7.36	Average	100	67	P
7	15870.00	14.97	43.48	58.45	74.00	-15.55	Peak	100	67	P

Note: Level=Reading+Factor
 Margin=Level-Limit
 Factor=Antenna Factor + cable loss - Amplifier Factor



Power	: AC 120V / 60Hz	Pol/Phase	: VERTICAL
Test Mode	: Mode 1, Band 3, CH100		:

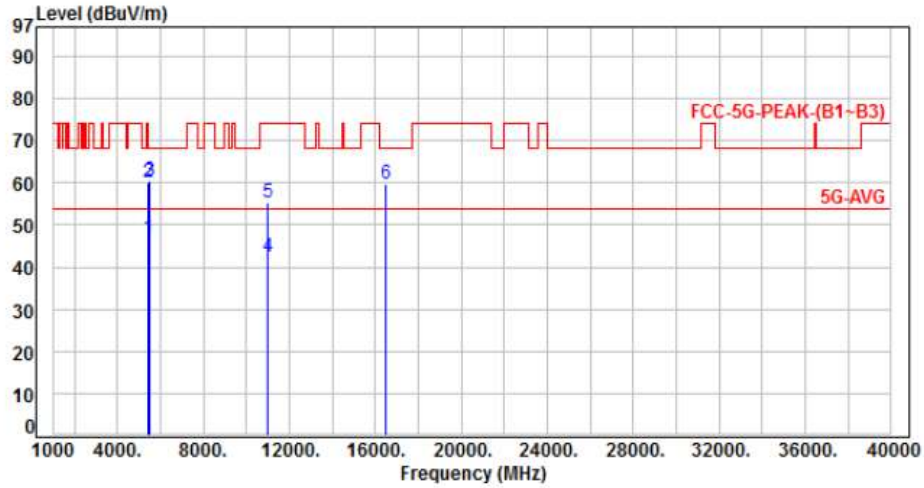

No.	Frequency (MHz)	Factor (dB)	Reading (dBuV)	Level (dBuV/m)	Limit (dBuV/m)	Margin (dB)	Detector	Height (cm)	Azimuth (deg)	P/F
1	5460.00	6.54	40.46	47.00	54.00	-7.00	Average	100	95	P
2	5460.00	6.54	53.58	60.12	74.00	-13.88	Peak	100	95	P
3	5470.00	6.58	53.93	60.51	68.20	-7.69	Peak	100	95	P
4	11000.00	13.91	28.37	42.28	54.00	-11.72	Average	100	35	P
5	11000.00	13.91	41.35	55.26	74.00	-18.74	Peak	100	35	P
6	16500.00	16.13	43.67	59.80	68.20	-8.40	Peak	100	267	P

Note: Level=Reading+Factor
 Margin=Level-Limit
 Factor=Antenna Factor + cable loss - Amplifier Factor



Power	: AC 120V / 60Hz	Pol/Phase	: HORIZONTAL
Test Mode	: Mode 1, Band 3, CH100		:

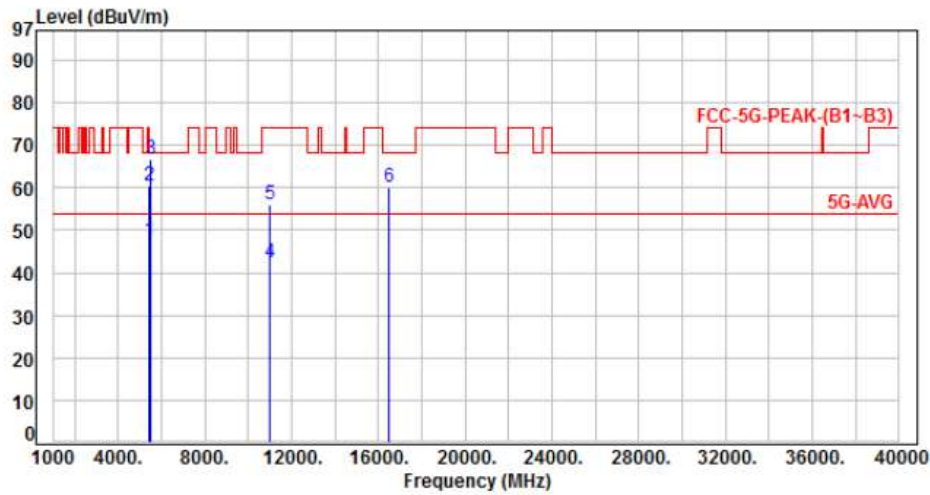

No.	Frequency (MHz)	Factor (dB)	Reading (dBuV)	Level (dBuV/m)	Limit (dBuV/m)	Margin (dB)	Detector	Height (cm)	Azimuth (deg)	P/F
1	5460.00	6.54	41.09	47.63	54.00	-6.37	Average	100	20	P
2	5460.00	6.54	54.12	60.66	74.00	-13.34	Peak	100	20	P
3	5470.00	6.58	60.04	66.62	68.20	-1.58	Peak	100	20	P
4	11000.00	13.91	28.63	42.54	54.00	-11.46	Average	100	63	P
5	11000.00	13.91	42.18	56.09	74.00	-17.91	Peak	100	63	P
6	16500.00	16.13	43.93	60.06	68.20	-8.14	Peak	100	293	P

Note: Level=Reading+Factor
 Margin=Level-Limit
 Factor=Antenna Factor + cable loss - Amplifier Factor



Power	: AC 120V / 60Hz	Pol/Phase	: VERTICAL
Test Mode	: Mode 1, Band 3, CH120		:

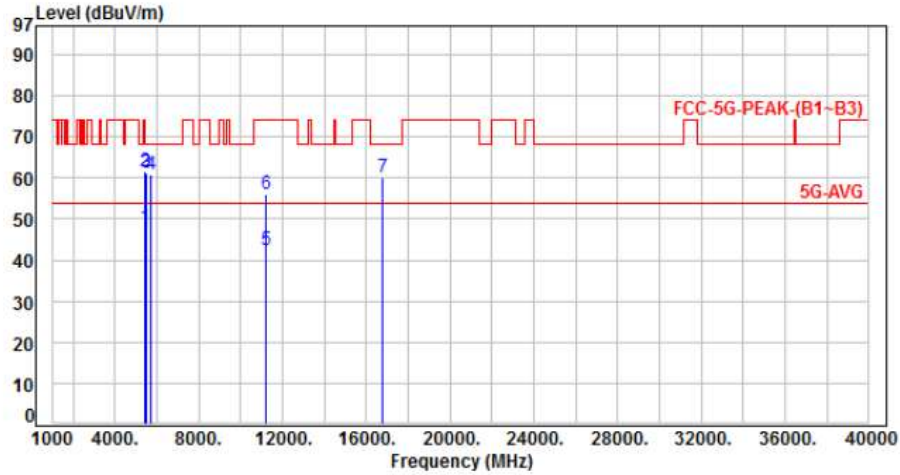

No.	Frequency (MHz)	Factor (dB)	Reading (dBuV)	Level (dBuV/m)	Limit (dBuV/m)	Margin (dB)	Detector	Height (cm)	Azimuth (deg)	P/F
1	5460.00	6.54	41.24	47.78	54.00	-6.22	Average	100	122	P
2	5460.00	6.54	54.98	61.52	74.00	-12.48	Peak	100	122	P
3	5470.00	6.58	54.47	61.05	68.20	-7.15	Peak	100	122	P
4	5725.00	6.52	54.22	60.74	68.20	-7.46	Peak	100	122	P
5	11200.00	14.19	28.32	42.51	54.00	-11.49	Average	100	131	P
6	11200.00	14.19	41.94	56.13	74.00	-17.87	Peak	100	131	P
7	16800.00	17.85	42.19	60.04	68.20	-8.16	Peak	100	81	P

Note: Level=Reading+Factor
 Margin=Level-Limit
 Factor=Antenna Factor + cable loss - Amplifier Factor



Power	: AC 120V / 60Hz	Pol/Phase	: HORIZONTAL
Test Mode	: Mode 1, Band 3, CH120		:

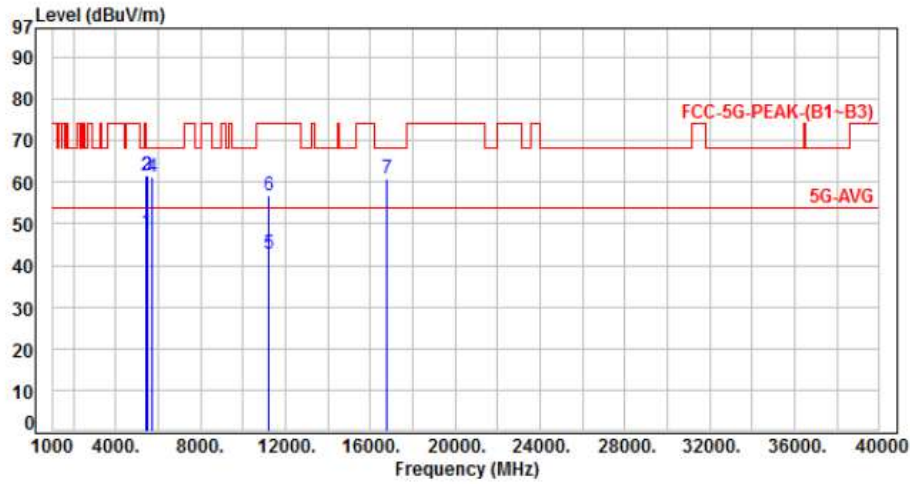

No.	Frequency (MHz)	Factor (dB)	Reading (dBuV)	Level (dBuV/m)	Limit (dBuV/m)	Margin (dB)	Detector	Height (cm)	Azimuth (deg)	P/F
1	5460.00	6.54	41.32	47.86	54.00	-6.14	Average	100	52	P
2	5460.00	6.54	55.21	61.75	74.00	-12.25	Peak	100	52	P
3	5470.00	6.58	54.91	61.49	68.20	-6.71	Peak	100	52	P
4	5725.00	6.52	54.79	61.31	68.20	-6.89	Peak	100	52	P
5	11200.00	14.19	28.54	42.73	54.00	-11.27	Average	100	153	P
6	11200.00	14.19	42.51	56.70	74.00	-17.30	Peak	100	153	P
7	16800.00	17.85	42.88	60.73	68.20	-7.47	Peak	100	307	P

Note: Level=Reading+Factor
 Margin=Level-Limit
 Factor=Antenna Factor + cable loss - Amplifier Factor



Power	: AC 120V / 60Hz	Pol/Phase	: VERTICAL
Test Mode	: Mode 1, Band 3, CH140		:

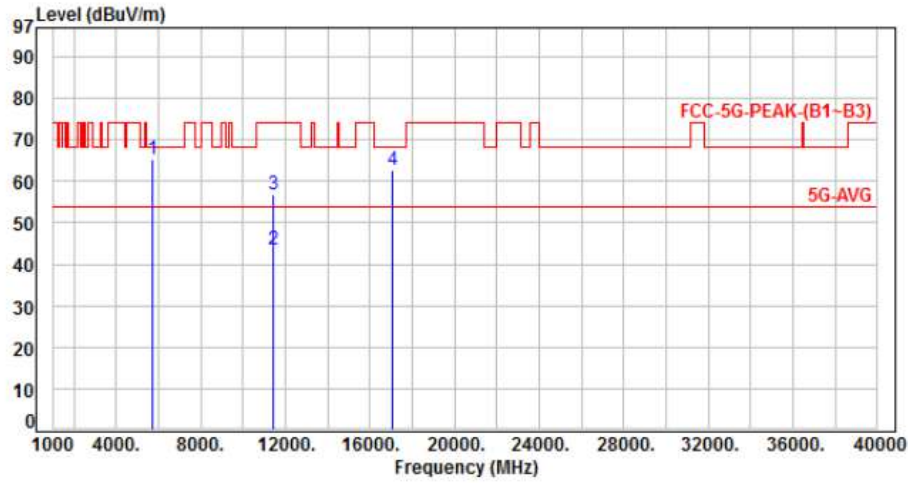

No.	Frequency (MHz)	Factor (dB)	Reading (dBuV)	Level (dBuV/m)	Limit (dBuV/m)	Margin (dB)	Detector	Height (cm)	Azimuth (deg)	P/F
1	5725.00	6.52	58.59	65.11	68.20	-3.09	Peak	100	65	P
2	11400.00	14.39	29.16	43.55	54.00	-10.45	Average	100	134	P
3	11400.00	14.39	42.34	56.73	74.00	-17.27	Peak	100	134	P
4	17100.00	19.30	43.42	62.72	68.20	-5.48	Peak	100	42	P

Note: Level=Reading+Factor
 Margin=Level-Limit
 Factor=Antenna Factor + cable loss - Amplifier Factor



Power	: AC 120V / 60Hz	Pol/Phase	: HORIZONTAL
Test Mode	: Mode 1, Band 3, CH140		:

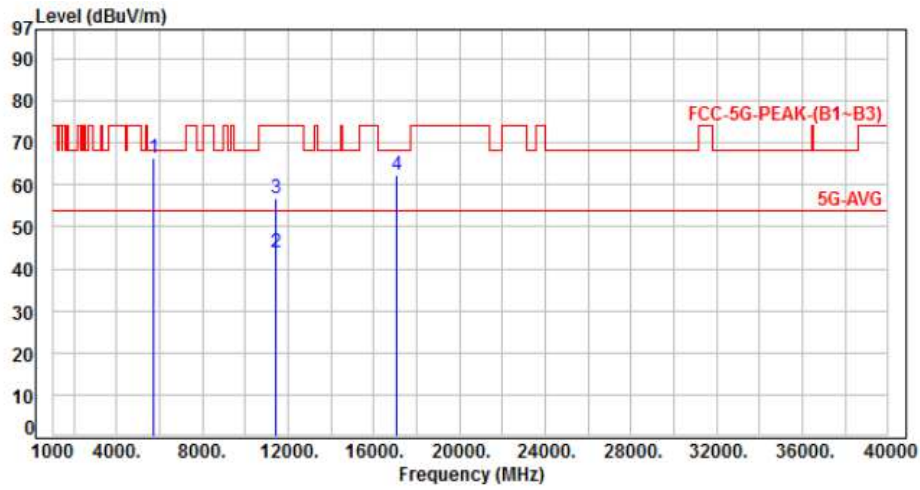

No.	Frequency (MHz)	Factor (dB)	Reading (dBuV)	Level (dBuV/m)	Limit (dBuV/m)	Margin (dB)	Detector	Height (cm)	Azimuth (deg)	P/F
1	5725.00	6.52	59.79	66.31	68.20	-1.89	Peak	100	20	P
2	11400.00	14.39	29.39	43.78	54.00	-10.22	Average	100	39	P
3	11400.00	14.39	42.50	56.89	74.00	-17.11	Peak	100	39	P
4	17100.00	19.30	43.12	62.42	68.20	-5.78	Peak	100	112	P

Note: Level=Reading+Factor
 Margin=Level-Limit
 Factor=Antenna Factor + cable loss - Amplifier Factor



Power	: AC 120V / 60Hz	Pol/Phase	: VERTICAL
Test Mode	: Mode 2, Band 3, CH100		:

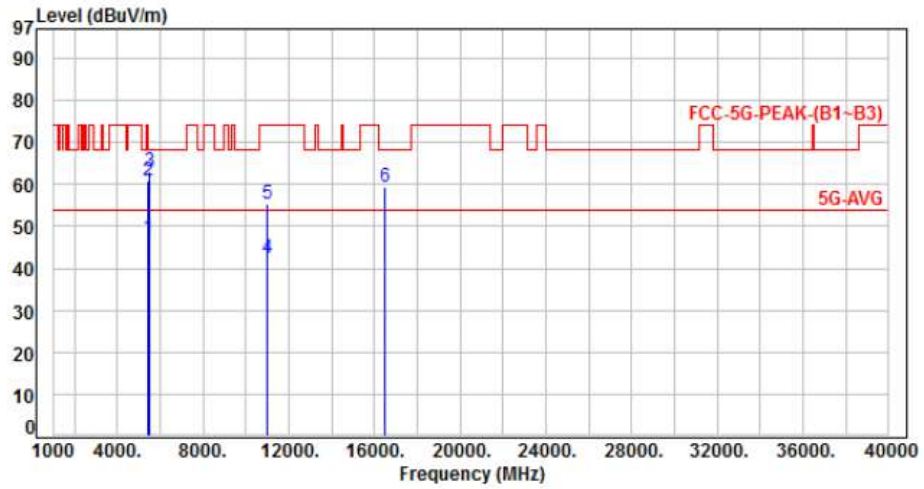

No.	Frequency (MHz)	Factor (dB)	Reading (dBuV)	Level (dBuV/m)	Limit (dBuV/m)	Margin (dB)	Detector	Height (cm)	Azimuth (deg)	P/F
1	5460.00	6.54	40.81	47.35	54.00	-6.65	Average	100	55	P
2	5460.00	6.54	54.38	60.92	74.00	-13.08	Peak	100	55	P
3	5470.00	6.58	56.41	62.99	68.20	-5.21	Peak	100	55	P
4	11000.00	13.91	28.53	42.44	54.00	-11.56	Average	100	153	P
5	11000.00	13.91	41.55	55.46	74.00	-18.54	Peak	100	153	P
6	16500.00	16.13	43.37	59.50	68.20	-8.70	Peak	100	137	P

Note: Level=Reading+Factor
 Margin=Level-Limit
 Factor=Antenna Factor + cable loss - Amplifier Factor



Power	: AC 120V / 60Hz	Pol/Phase	: HORIZONTAL
Test Mode	: Mode 2, Band 3, CH100		:

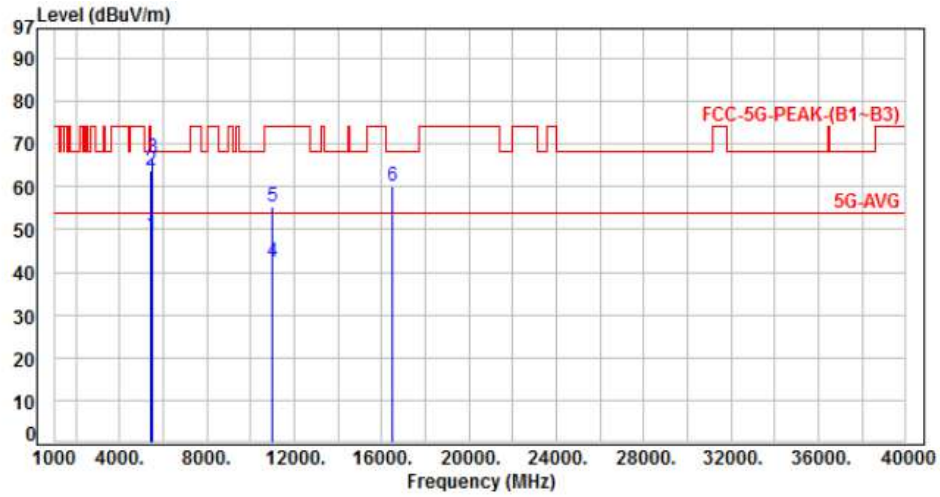

No.	Frequency (MHz)	Factor (dB)	Reading (dBuV)	Level (dBuV/m)	Limit (dBuV/m)	Margin (dB)	Detector	Height (cm)	Azimuth (deg)	P/F
1	5460.00	6.54	41.96	48.50	54.00	-5.50	Average	100	20	P
2	5460.00	6.54	57.11	63.65	74.00	-10.35	Peak	100	20	P
3	5470.00	6.58	60.03	66.61	68.20	-1.59	Peak	100	20	P
4	11000.00	13.91	28.36	42.27	54.00	-11.73	Average	100	248	P
5	11000.00	13.91	41.48	55.39	74.00	-18.61	Peak	100	248	P
6	16500.00	16.13	43.95	60.08	68.20	-8.12	Peak	100	95	P

Note: Level=Reading+Factor
Margin=Level-Limit
Factor=Antenna Factor + cable loss - Amplifier Factor



Power	: AC 120V / 60Hz	Pol/Phase	: VERTICAL
Test Mode	: Mode 2, Band 3, CH120		

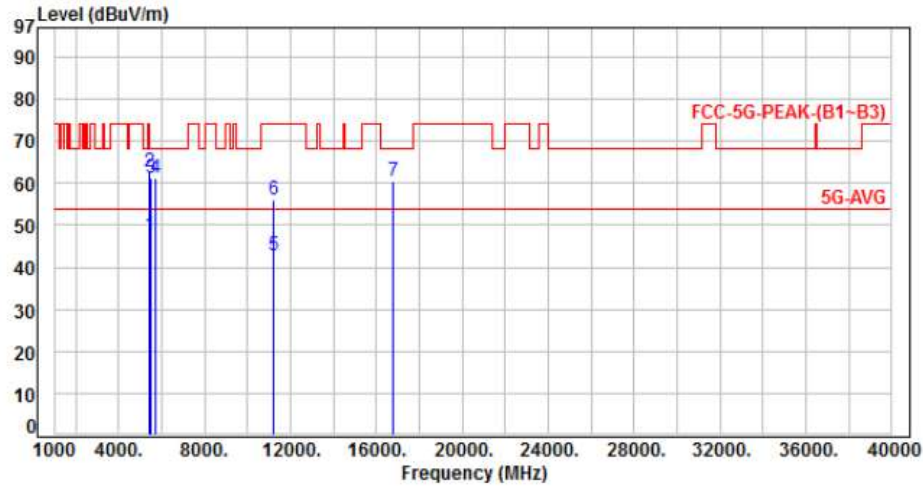

No.	Frequency (MHz)	Factor (dB)	Reading (dBuV)	Level (dBuV/m)	Limit (dBuV/m)	Margin (dB)	Detector	Height (cm)	Azimuth (deg)	P/F
1	5460.00	6.54	41.09	47.63	54.00	-6.37	Average	100	133	P
2	5460.00	6.54	56.13	62.67	74.00	-11.33	Peak	100	133	P
3	5470.00	6.58	54.61	61.19	68.20	-7.01	Peak	100	133	P
4	5725.00	6.52	54.53	61.05	68.20	-7.15	Peak	100	133	P
5	11200.00	14.19	28.57	42.76	54.00	-11.24	Average	100	56	P
6	11200.00	14.19	41.72	55.91	74.00	-18.09	Peak	100	56	P
7	16800.00	17.85	42.54	60.39	68.20	-7.81	Peak	100	154	P

Note: Level=Reading+Factor
 Margin=Level-Limit
 Factor=Antenna Factor + cable loss - Amplifier Factor



Power	: AC 120V / 60Hz	Pol/Phase	: HORIZONTAL
Test Mode	: Mode 2, Band 3, CH120		:

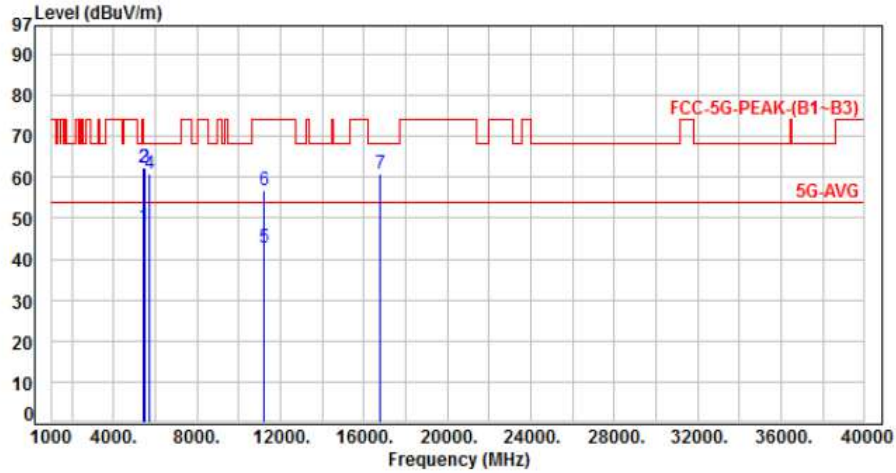

No.	Frequency (MHz)	Factor (dB)	Reading (dBuV)	Level (dBuV/m)	Limit (dBuV/m)	Margin (dB)	Detector	Height (cm)	Azimuth (deg)	P/F
1	5460.00	6.54	41.29	47.83	54.00	-6.17	Average	100	37	P
2	5460.00	6.54	55.86	62.40	74.00	-11.60	Peak	100	37	P
3	5470.00	6.58	55.70	62.28	68.20	-5.92	Peak	100	37	P
4	5725.00	6.52	54.38	60.90	68.20	-7.30	Peak	100	37	P
5	11200.00	14.19	28.70	42.89	54.00	-11.11	Average	100	169	P
6	11200.00	14.19	42.75	56.94	74.00	-17.06	Peak	100	169	P
7	16800.00	17.85	43.11	60.96	68.20	-7.24	Peak	100	111	P

Note: Level=Reading+Factor
Margin=Level-Limit
Factor=Antenna Factor + cable loss - Amplifier Factor



Power	: AC 120V / 60Hz	Pol/Phase	: VERTICAL
Test Mode	: Mode 2, Band 3, CH140		:

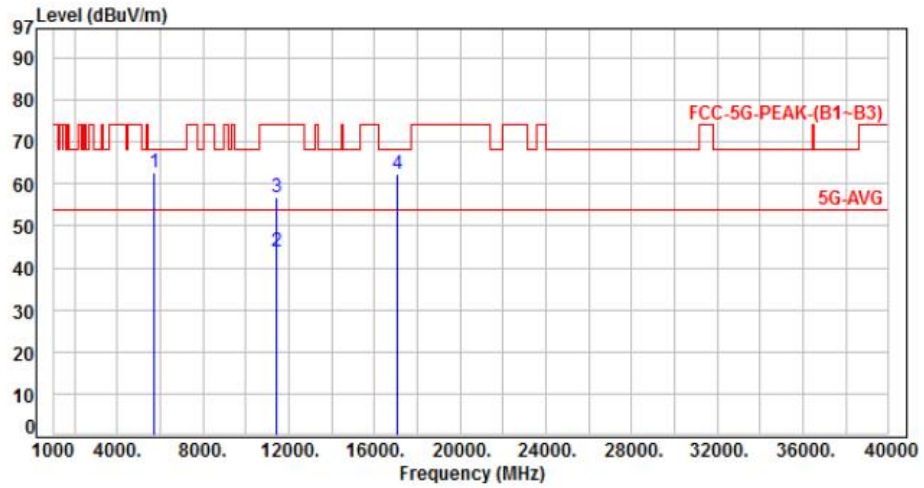

No.	Frequency (MHz)	Factor (dB)	Reading (dBuV)	Level (dBuV/m)	Limit (dBuV/m)	Margin (dB)	Detector	Height (cm)	Azimuth (deg)	P/F
1	5725.00	6.52	56.36	62.88	68.20	-5.32	Peak	100	40	P
2	11400.00	14.39	29.36	43.75	54.00	-10.25	Average	100	36	P
3	11400.00	14.39	42.26	56.65	74.00	-17.35	Peak	100	36	P
4	17100.00	19.30	43.14	62.44	68.20	-5.76	Peak	100	114	P

Note: Level=Reading+Factor
Margin=Level-Limit
Factor=Antenna Factor + cable loss - Amplifier Factor



Power	: AC 120V / 60Hz	Pol/Phase	: HORIZONTAL
Test Mode	: Mode 2, Band 3, CH140		:

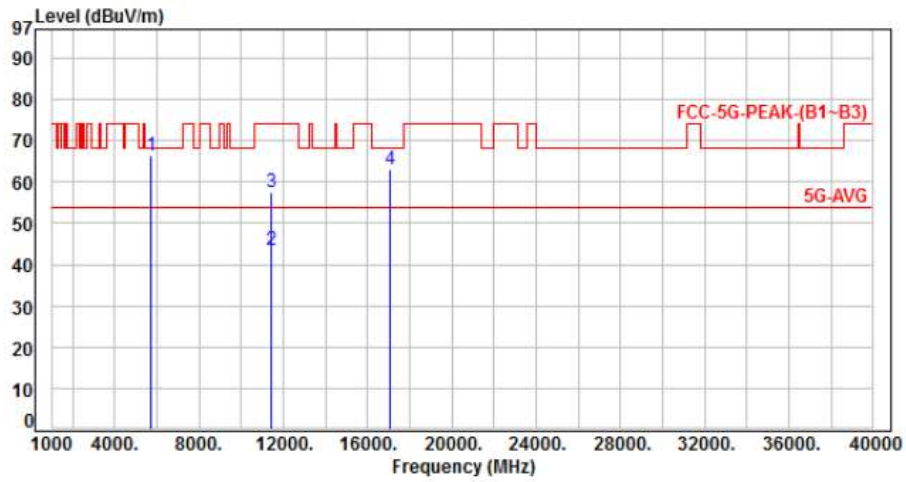

No.	Frequency (MHz)	Factor (dB)	Reading (dBuV)	Level (dBuV/m)	Limit (dBuV/m)	Margin (dB)	Detector	Height (cm)	Azimuth (deg)	P/F
1	5725.00	6.52	59.87	66.39	68.20	-1.81	Peak	105	35	P
2	11400.00	14.39	29.10	43.49	54.00	-10.51	Average	100	105	P
3	11400.00	14.39	43.05	57.44	74.00	-16.56	Peak	100	105	P
4	17100.00	19.30	43.75	63.05	68.20	-5.15	Peak	100	75	P

Note: Level=Reading+Factor
Margin=Level-Limit
Factor=Antenna Factor + cable loss - Amplifier Factor



Power	: AC 120V / 60Hz	Pol/Phase	: VERTICAL
Test Mode	: Mode 3, Band 3, CH102		:

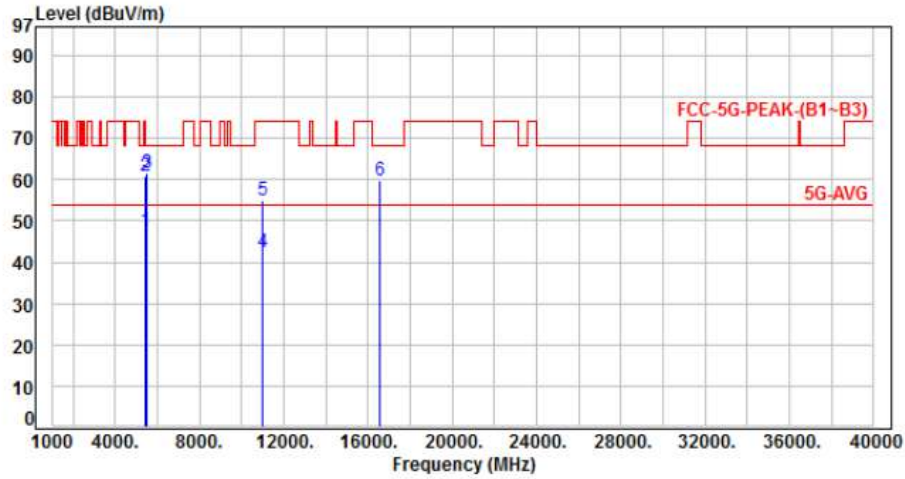

No.	Frequency (MHz)	Factor (dB)	Reading (dBuV)	Level (dBuV/m)	Limit (dBuV/m)	Margin (dB)	Detector	Height (cm)	Azimuth (deg)	P/F
1	5460.00	6.54	41.11	47.65	54.00	-6.35	Average	100	65	P
2	5460.00	6.54	54.34	60.88	74.00	-13.12	Peak	100	65	P
3	5470.00	6.58	55.05	61.63	68.20	-6.57	Peak	100	65	P
4	11020.00	13.96	28.62	42.58	54.00	-11.42	Average	100	97	P
5	11020.00	13.96	40.97	54.93	74.00	-19.07	Peak	100	97	P
6	16530.00	16.35	43.53	59.88	68.20	-8.32	Peak	100	154	P

Note: Level=Reading+Factor
Margin=Level-Limit
Factor=Antenna Factor + cable loss - Amplifier Factor



Power	: AC 120V / 60Hz	Pol/Phase	: HORIZONTAL
Test Mode	: Mode 3, Band 3, CH102		:

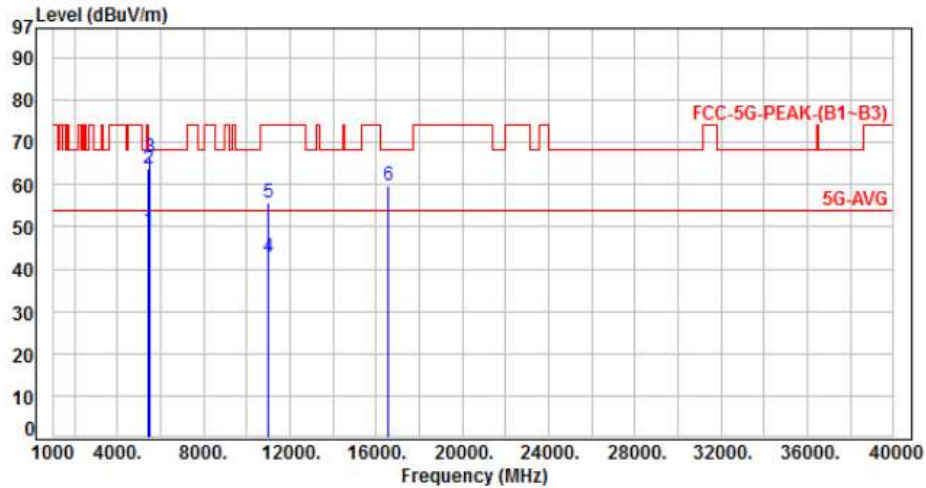

No.	Frequency (MHz)	Factor (dB)	Reading (dBuV)	Level (dBuV/m)	Limit (dBuV/m)	Margin (dB)	Detector	Height (cm)	Azimuth (deg)	P/F
1	5460.00	6.54	42.51	49.05	54.00	-4.95	Average	100	20	P
2	5460.00	6.54	57.25	63.79	74.00	-10.21	Peak	100	20	P
3	5470.00	6.58	59.75	66.33	68.20	-1.87	Peak	100	20	P
4	11020.00	13.96	28.69	42.65	54.00	-11.35	Average	100	69	P
5	11020.00	13.96	41.57	55.53	74.00	-18.47	Peak	100	69	P
6	16530.00	16.35	43.54	59.89	68.20	-8.31	Peak	100	155	P

Note: Level=Reading+Factor
Margin=Level-Limit
Factor=Antenna Factor + cable loss - Amplifier Factor



Power	: AC 120V / 60Hz	Pol/Phase	: VERTICAL
Test Mode	: Mode 3, Band 3, CH118		:

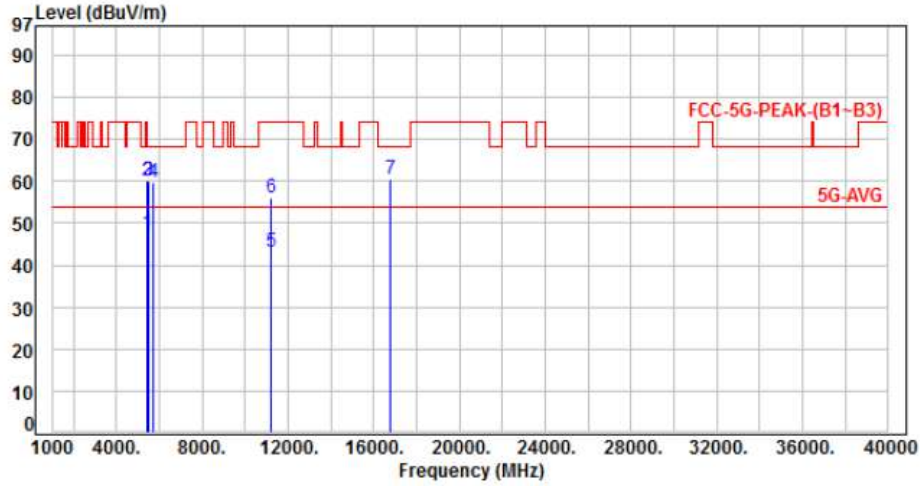

No.	Frequency (MHz)	Factor (dB)	Reading (dBuV)	Level (dBuV/m)	Limit (dBuV/m)	Margin (dB)	Detector	Height (cm)	Azimuth (deg)	P/F
1	5460.00	6.54	41.07	47.61	54.00	-6.39	Average	100	73	P
2	5460.00	6.54	53.44	59.98	74.00	-14.02	Peak	100	73	P
3	5470.00	6.58	53.38	59.96	68.20	-8.24	Peak	100	73	P
4	5725.00	6.52	53.40	59.92	68.20	-8.28	Peak	100	60	P
5	11180.00	14.19	28.87	43.06	54.00	-10.94	Average	100	87	P
6	11180.00	14.19	41.93	56.12	74.00	-17.88	Peak	100	87	P
7	16770.00	17.58	42.79	60.37	68.20	-7.83	Peak	100	179	P

Note: Level=Reading+Factor
 Margin=Level-Limit
 Factor=Antenna Factor + cable loss - Amplifier Factor



Power	: AC 120V / 60Hz	Pol/Phase	: HORIZONTAL
Test Mode	: Mode 3, Band 3, CH118		:

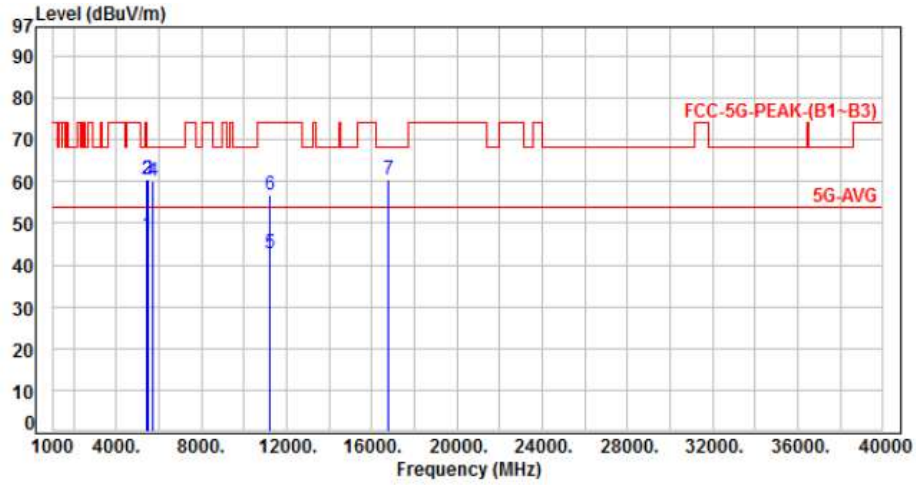

No.	Frequency (MHz)	Factor (dB)	Reading (dBuV)	Level (dBuV/m)	Limit (dBuV/m)	Margin (dB)	Detector	Height (cm)	Azimuth (deg)	P/F
1	5460.00	6.54	40.84	47.38	54.00	-6.62	Average	100	27	P
2	5460.00	6.54	53.96	60.50	74.00	-13.50	Peak	100	27	P
3	5470.00	6.58	54.05	60.63	68.20	-7.57	Peak	100	27	P
4	5725.00	6.52	53.55	60.07	68.20	-8.13	Peak	100	27	P
5	11180.00	14.19	28.51	42.70	54.00	-11.30	Average	100	145	P
6	11180.00	14.19	42.55	56.74	74.00	-17.26	Peak	100	145	P
7	16770.00	17.58	42.91	60.49	68.20	-7.71	Peak	100	355	P

Note: Level=Reading+Factor
 Margin=Level-Limit
 Factor=Antenna Factor + cable loss - Amplifier Factor



Power	: AC 120V / 60Hz	Pol/Phase	: VERTICAL
Test Mode	: Mode 3, Band 3, CH134		:

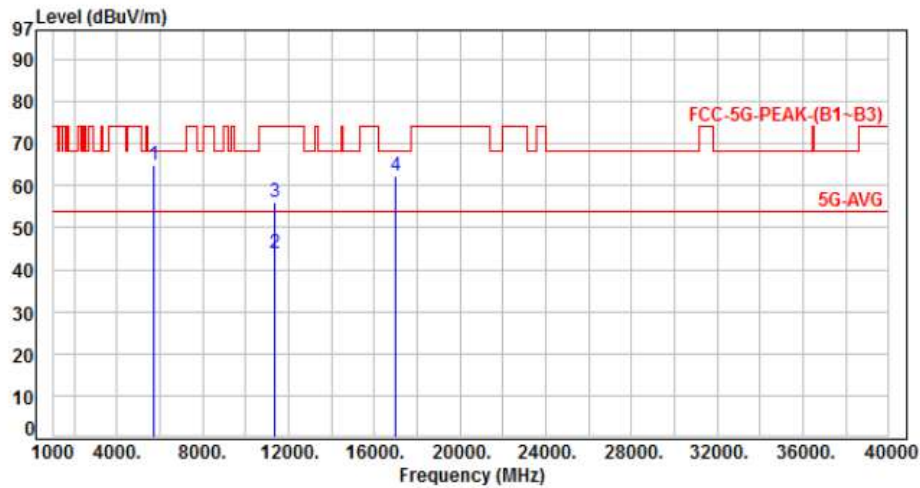

No.	Frequency (MHz)	Factor (dB)	Reading (dBuV)	Level (dBuV/m)	Limit (dBuV/m)	Margin (dB)	Detector	Height (cm)	Azimuth (deg)	P/F
1	5725.00	6.52	58.33	64.85	68.20	-3.35	Peak	100	65	P
2	11340.00	14.30	29.53	43.83	54.00	-10.17	Average	100	218	P
3	11340.00	14.30	41.88	56.18	74.00	-17.82	Peak	100	218	P
4	17010.00	18.99	43.24	62.23	68.20	-5.97	Peak	100	24	P

Note: Level=Reading+Factor
 Margin=Level-Limit
 Factor=Antenna Factor + cable loss - Amplifier Factor



Power	: AC 120V / 60Hz	Pol/Phase	: HORIZONTAL
Test Mode	: Mode 3, Band 3, CH134		:

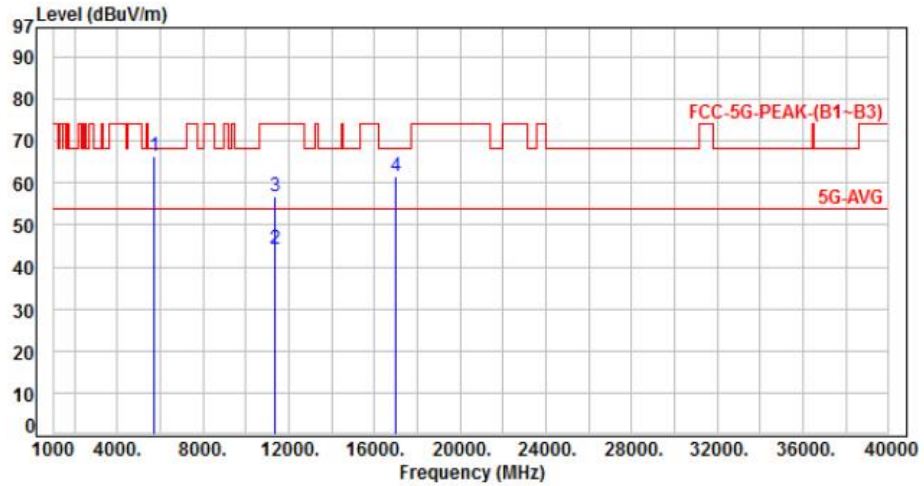

No.	Frequency (MHz)	Factor (dB)	Reading (dBuV)	Level (dBuV/m)	Limit (dBuV/m)	Margin (dB)	Detector	Height (cm)	Azimuth (deg)	P/F
1	5725.00	6.52	59.71	66.23	68.20	-1.97	Peak	100	20	P
2	11340.00	14.30	30.08	44.38	54.00	-9.62	Average	100	49	P
3	11340.00	14.30	42.41	56.71	74.00	-17.29	Peak	100	49	P
4	17010.00	18.99	42.53	61.52	68.20	-6.68	Peak	100	253	P

Note: Level=Reading+Factor
Margin=Level-Limit
Factor=Antenna Factor + cable loss - Amplifier Factor



Power	: AC 120V / 60Hz	Pol/Phase	: VERTICAL
Test Mode	: Mode 4, Band 3, CH106		:

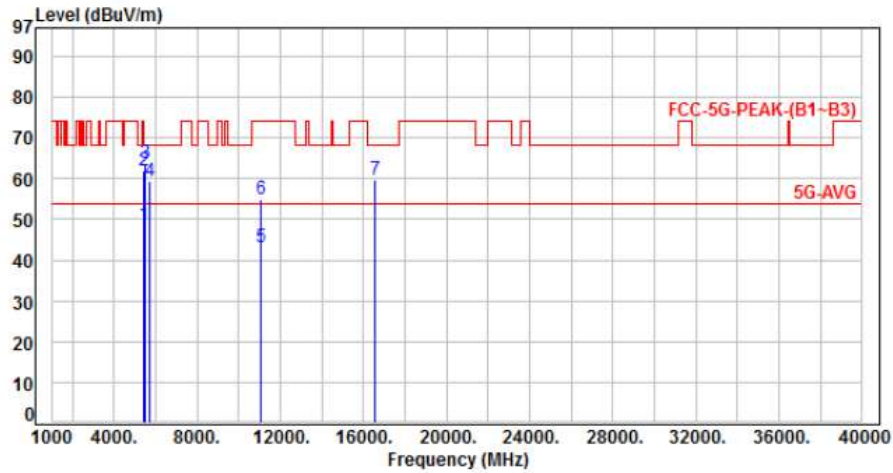

No.	Frequency (MHz)	Factor (dB)	Reading (dBuV)	Level (dBuV/m)	Limit (dBuV/m)	Margin (dB)	Detector	Height (cm)	Azimuth (deg)	P/F
1	5460.00	6.54	42.29	48.83	54.00	-5.17	Average	100	55	P
2	5460.00	6.54	55.44	61.98	74.00	-12.02	Peak	100	55	P
3	5470.00	6.58	57.22	63.80	68.20	-4.40	Peak	100	55	P
4	5725.00	6.52	52.83	59.35	68.20	-8.85	Peak	100	55	P
5	11060.00	14.06	28.97	43.03	54.00	-10.97	Average	100	337	P
6	11060.00	14.06	40.93	54.99	74.00	-19.01	Peak	100	337	P
7	16590.00	16.77	42.99	59.76	68.20	-8.44	Peak	100	139	P

Note: Level=Reading+Factor
 Margin=Level-Limit
 Factor=Antenna Factor + cable loss - Amplifier Factor



Power	: AC 120V / 60Hz	Pol/Phase	: HORIZONTAL
Test Mode	: Mode 4, Band 3, CH106		:

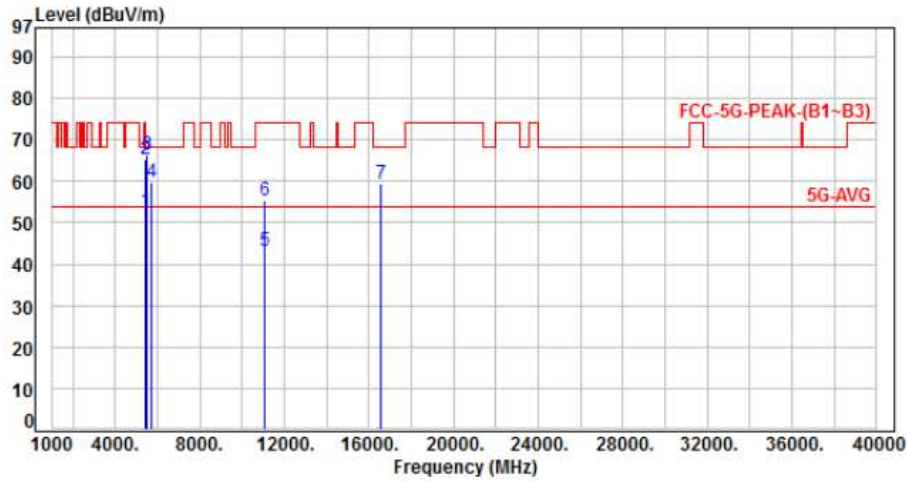

No.	Frequency (MHz)	Factor (dB)	Reading (dBuV)	Level (dBuV/m)	Limit (dBuV/m)	Margin (dB)	Detector	Height (cm)	Azimuth (deg)	P/F
1	5460.00	6.54	46.06	52.60	54.00	-1.40	Average	100	20	P
2	5460.00	6.54	58.69	65.23	74.00	-8.77	Peak	100	20	P
3	5470.00	6.58	59.86	66.44	68.20	-1.76	Peak	100	20	P
4	5725.00	6.52	53.15	59.67	68.20	-8.53	Peak	100	20	P
5	11060.00	14.06	29.00	43.06	54.00	-10.94	Average	100	10	P
6	11060.00	14.06	41.31	55.37	74.00	-18.63	Peak	100	10	P
7	16590.00	16.77	42.47	59.24	68.20	-8.96	Peak	100	47	P

Note: Level=Reading+Factor
 Margin=Level-Limit
 Factor=Antenna Factor + cable loss - Amplifier Factor



Power	: AC 120V / 60Hz	Pol/Phase	: VERTICAL
Test Mode	: Mode 4, Band 3, CH122		:

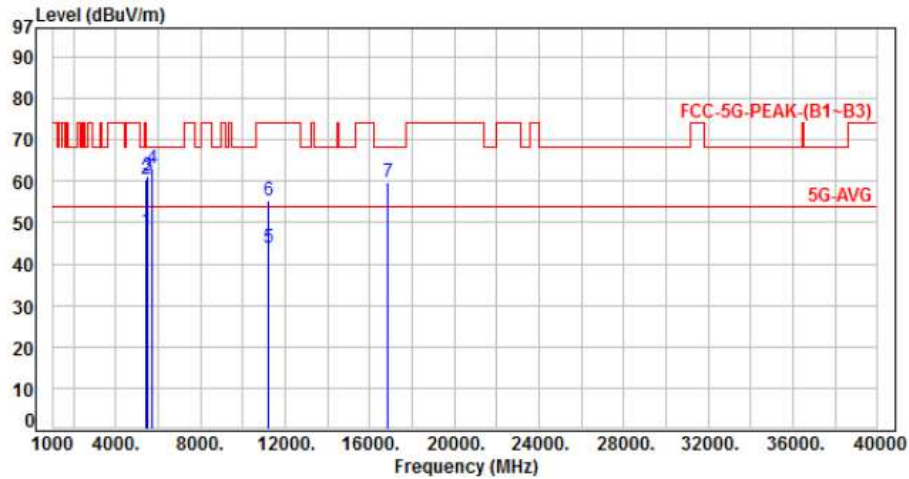

No.	Frequency (MHz)	Factor (dB)	Reading (dBuV)	Level (dBuV/m)	Limit (dBuV/m)	Margin (dB)	Detector	Height (cm)	Azimuth (deg)	P/F
1	5460.00	6.54	41.51	48.05	54.00	-5.95	Average	100	60	P
2	5460.00	6.54	53.96	60.50	74.00	-13.50	Peak	100	60	P
3	5470.00	6.58	54.53	61.11	68.20	-7.09	Peak	100	60	P
4	5725.00	6.52	56.68	63.20	68.20	-5.00	Peak	100	60	P
5	11220.00	14.21	29.83	44.04	54.00	-9.96	Average	100	183	P
6	11220.00	14.21	41.14	55.35	74.00	-18.65	Peak	100	183	P
7	16830.00	18.09	41.83	59.92	68.20	-8.28	Peak	100	103	P

Note: Level=Reading+Factor
Margin=Level-Limit
Factor=Antenna Factor + cable loss - Amplifier Factor



Power	: AC 120V / 60Hz	Pol/Phase	: HORIZONTAL
Test Mode	: Mode 4, Band 3, CH122		

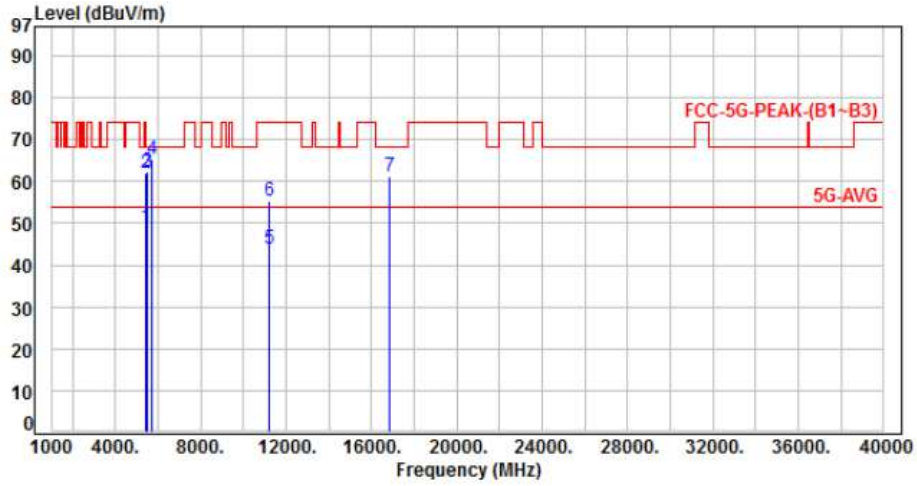

No.	Frequency (MHz)	Factor (dB)	Reading (dBuV)	Level (dBuV/m)	Limit (dBuV/m)	Margin (dB)	Detector	Height (cm)	Azimuth (deg)	P/F
1	5460.00	6.54	42.69	49.23	54.00	-4.77	Average	100	20	P
2	5460.00	6.54	55.29	61.83	74.00	-12.17	Peak	100	20	P
3	5470.00	6.58	55.80	62.38	68.20	-5.82	Peak	100	20	P
4	5725.00	6.52	58.69	65.21	68.20	-2.99	Peak	100	20	P
5	11220.00	14.21	29.75	43.96	54.00	-10.04	Average	100	96	P
6	11220.00	14.21	40.96	55.17	74.00	-18.83	Peak	100	96	P
7	16830.00	18.09	43.06	61.15	68.20	-7.05	Peak	100	60	P

Note: Level=Reading+Factor
 Margin=Level-Limit
 Factor=Antenna Factor + cable loss - Amplifier Factor