

Test Laboratory: BTL Inc.

Date: 2016/8/11

System Check_B2450_0811

DUT: Dipole 2450 MHz D2450V2;SN:919;

Communication System: UID 0, CW (0); Frequency: 2450 MHz; Duty Cycle: 1:1

Medium parameters used: $f = 2450$ MHz; $\sigma = 1.989$ S/m; $\epsilon_r = 50.35$; $\rho = 1000$ kg/m³

Ambient Temperature: 23.5°C; Liquid Temperature: 22.4°C

DASY Configuration:

- Probe: EX3DV4 - SN3932; ConvF(7.52, 7.52, 7.52); Calibrated: 2016/2/19;
- Sensor-Surface: 4mm (Mechanical Surface Detection), $z = 1.0, 31.0$
- Electronics: DAE4 Sn1390; Calibrated: 2015/9/18
- Phantom: ELI v5.0; Type: QDOVA002AA; Serial: TP:1222
- DASY52 52.8.8(1222); SEMCAD X 14.6.10(7331)

Area Scan (6x8x1): Interpolated grid: dx=12 mm, dy=12 mm

Maximum value of SAR (interpolated) = 17.1 W/kg

Zoom Scan (7x7x7)/Cube 0: Measurement grid: dx=5mm, dy=5mm, dz=5mm

Reference Value = 102.1 V/m; Power Drift = -0.04 dB

Peak SAR (extrapolated) = 26.0 W/kg

SAR(1 g) = 13.1 W/kg; SAR(10 g) = 6.29 W/kg

Maximum value of SAR (measured) = 15.1 W/kg

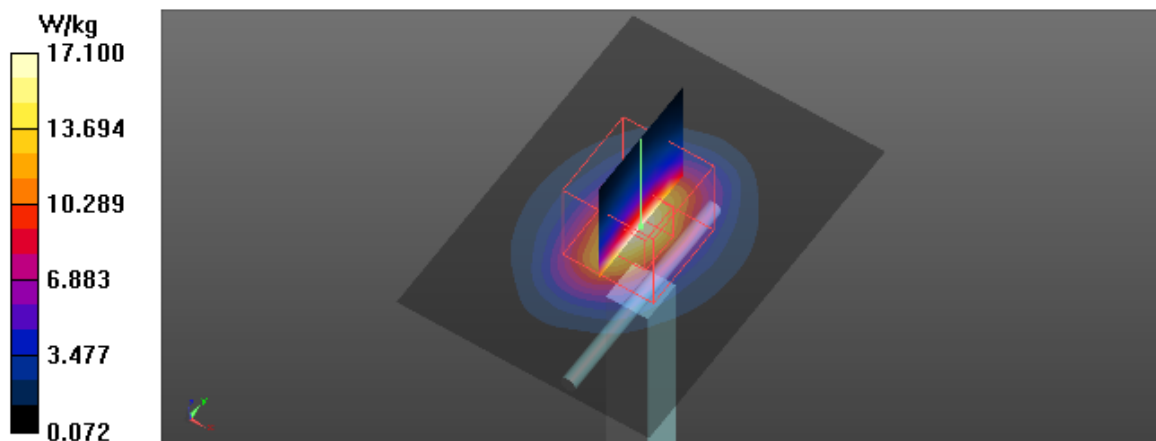

Test Laboratory: BTL Inc.

Date: 2016/8/10

System Check_B5200_0810

DUT: Dipole D5GHzV2;SN;1160;

Communication System: UID 0, CW (0); Frequency: 5200 MHz; Duty Cycle: 1:1

Medium parameters used: $f = 5200$ MHz; $\sigma = 5.307$ S/m; $\epsilon_r = 47.68$; $\rho = 996$ kg/m³

Ambient Temperature: 23.1 °C; Liquid Temperature: 22.6 °C

DASY Configuration:

- Probe: EX3DV4 - SN3932; ConvF(4.45, 4.45, 4.45); Calibrated: 2016/2/19;
- Sensor-Surface: 2mm (Mechanical Surface Detection), $z = 1.0, 23.0$
- Electronics: DAE4 Sn1390; Calibrated: 2015/9/18
- Phantom: ELI v5.0; Type: QDOVA002AA; Serial: TP:1222
- DASY52 52.8.8(1222); SEMCAD X 14.6.10(7331)

Area Scan (5x5x1): Interpolated grid: dx=10 mm, dy=10 mm

Maximum value of SAR (interpolated) = 14.8 W/kg

Zoom Scan (7x7x12)/Cube 0: Measurement grid: dx=4mm, dy=4mm, dz=2mm

Reference Value = 41.47 V/m; Power Drift = -0.03 dB

Peak SAR (extrapolated) = 24.9 W/kg

SAR(1 g) = 7.68 W/kg; SAR(10 g) = 2.29 W/kg

Maximum value of SAR (measured) = 15.3 W/kg

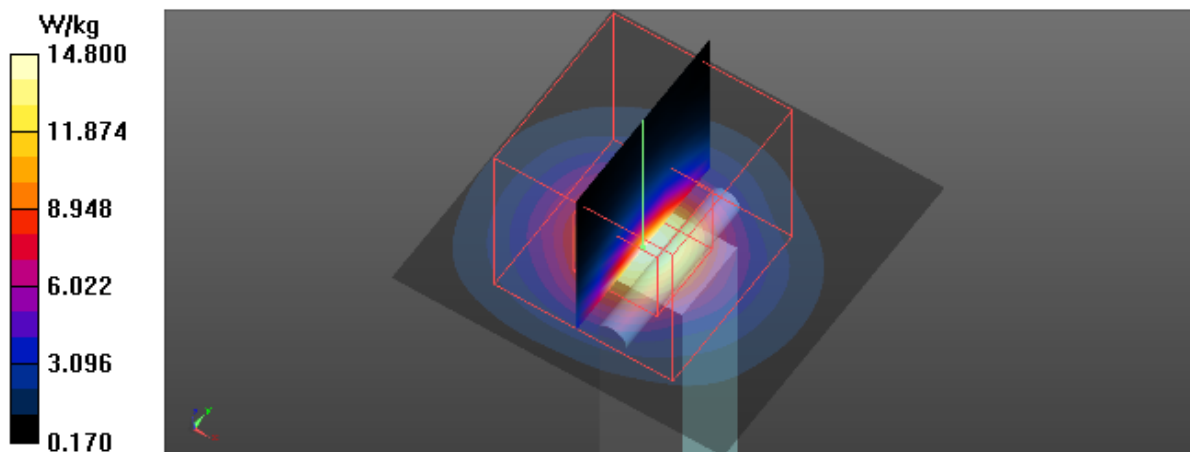

Test Laboratory: BTL Inc.

Date: 2016/8/10

System Check_B5300_0810

DUT: Dipole D5GHzV2;SN;1160;

Communication System: UID 0, CW (0); Frequency: 5300 MHz; Duty Cycle: 1:1

Medium parameters used: $f = 5300$ MHz; $\sigma = 5.506$ S/m; $\epsilon_r = 47.44$; $\rho = 996$ kg/m³

Ambient Temperature: 23.1 °C; Liquid Temperature: 22.6 °C

DASY Configuration:

- Probe: EX3DV4 - SN3932; ConvF(4.29, 4.29, 4.29); Calibrated: 2016/2/19;
- Sensor-Surface: 2mm (Mechanical Surface Detection), $z = 1.0, 23.0$
- Electronics: DAE4 Sn1390; Calibrated: 2015/9/18
- Phantom: ELI v5.0; Type: QDOVA002AA; Serial: TP:1222
- DASY52 52.8.8(1222); SEMCAD X 14.6.10(7331)

Area Scan (5x5x1): Interpolated grid: dx=10 mm, dy=10 mm

Maximum value of SAR (interpolated) = 16.7 W/kg

Zoom Scan (7x7x12)/Cube 0: Measurement grid: dx=4mm, dy=4mm, dz=2mm

Reference Value = 41.30 V/m; Power Drift = -0.08 dB

Peak SAR (extrapolated) = 27.4 W/kg

SAR(1 g) = 8.09 W/kg; SAR(10 g) = 2.39 W/kg

Maximum value of SAR (measured) = 16.3 W/kg

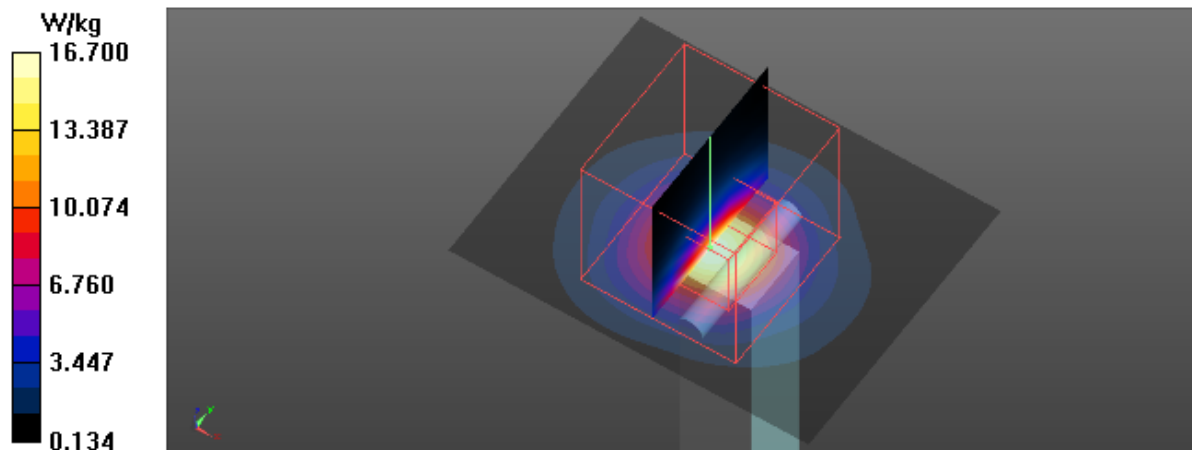

Test Laboratory: BTL Inc.

Date: 2016/8/10

System Check_B5600_0810

DUT: Dipole D5GHzV2;SN;1160;

Communication System: UID 0, CW (0); Frequency: 5600 MHz; Duty Cycle: 1:1

Medium parameters used: $f = 5600$ MHz; $\sigma = 5.818$ S/m; $\epsilon_r = 47$; $\rho = 996$ kg/m³

Ambient Temperature: 23.1 °C; Liquid Temperature: 22.6 °C

DASY Configuration:

- Probe: EX3DV4 - SN3932; ConvF(3.71, 3.71, 3.71); Calibrated: 2016/2/19;
- Sensor-Surface: 2mm (Mechanical Surface Detection), $z = 1.0, 23.0$
- Electronics: DAE4 Sn1390; Calibrated: 2015/9/18
- Phantom: ELI v5.0; Type: QDOVA002AA; Serial: TP:1222
- DASY52 52.8.8(1222); SEMCAD X 14.6.10(7331)

Area Scan (6x5x1): Interpolated grid: dx=10 mm, dy=10 mm

Maximum value of SAR (interpolated) = 18.2 W/kg

Zoom Scan (7x7x12)/Cube 0: Measurement grid: dx=4mm, dy=4mm, dz=2mm

Reference Value = 41.65 V/m; Power Drift = -0.09 dB

Peak SAR (extrapolated) = 29.8 W/kg

SAR(1 g) = 8.69 W/kg; SAR(10 g) = 2.55 W/kg

Maximum value of SAR (measured) = 17.9 W/kg

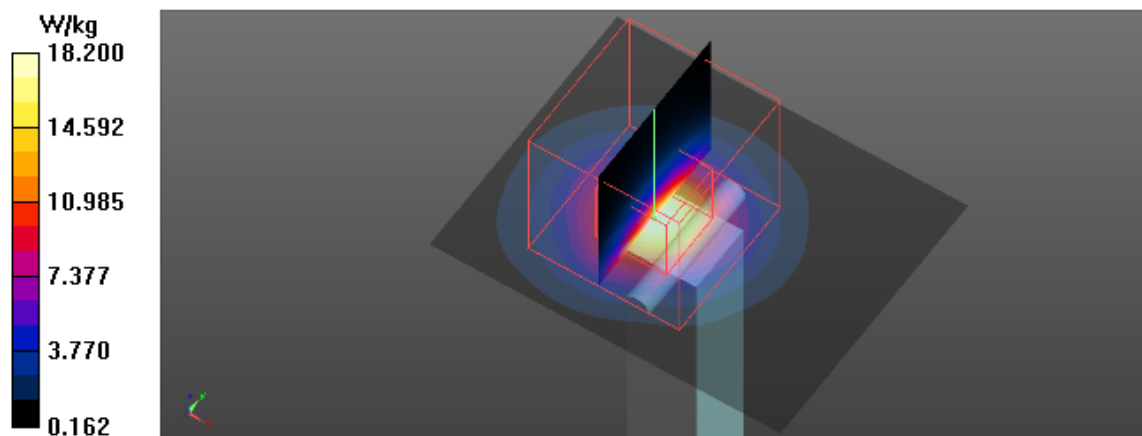

Test Laboratory: BTL Inc.

Date: 2016/8/10

System Check_B5800_0810

DUT: Dipole D5GHzV2;SN;1160;

Communication System: UID 0, CW (0); Frequency: 5800 MHz; Duty Cycle: 1:1

Medium parameters used: $f = 5800$ MHz; $\sigma = 6.141$ S/m; $\epsilon_r = 46.58$; $\rho = 996$ kg/m³

Ambient Temperature: 23.1 °C; Liquid Temperature: 22.6 °C

DASY Configuration:

- Probe: EX3DV4 - SN3932; ConvF(3.88, 3.88, 3.88); Calibrated: 2016/2/19;
- Sensor-Surface: 2mm (Mechanical Surface Detection), $z = 1.0, 31.0$
- Electronics: DAE4 Sn1390; Calibrated: 2015/9/18
- Phantom: ELI v5.0; Type: QDOVA002AA; Serial: TP:1222
- DASY52 52.8.8(1222); SEMCAD X 14.6.10(7331)

Area Scan (6x6x1): Interpolated grid: dx=10 mm, dy=10 mm

Maximum value of SAR (interpolated) = 21.2 W/kg

Zoom Scan (7x7x12)/Cube 0: Measurement grid: dx=4mm, dy=4mm, dz=2mm

Reference Value = 37.19 V/m; Power Drift = -0.06 dB

Peak SAR (extrapolated) = 40.3 W/kg

SAR(1 g) = 8.32 W/kg; SAR(10 g) = 2.82 W/kg

Maximum value of SAR (measured) = 18.9 W/kg

