

STRADDLE CHANNEL 144

HARMONICS AND SPURIOUS EMISSIONS (HORIZONTAL)

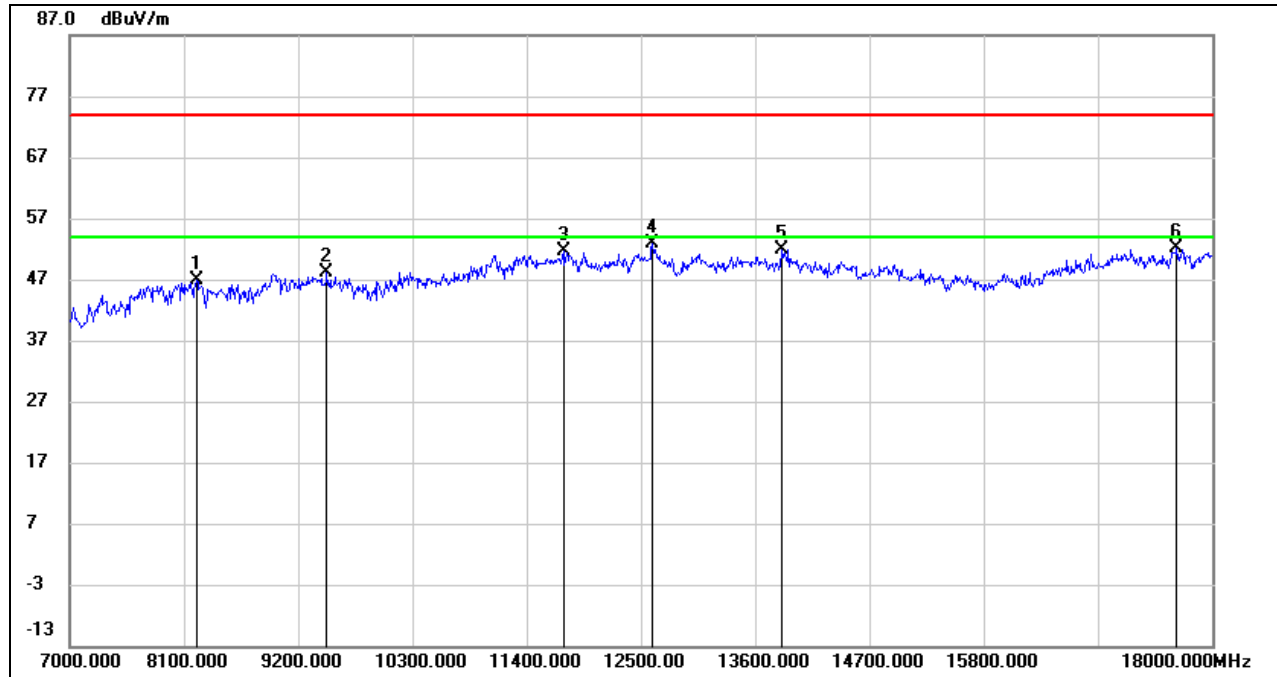

| No. | Frequency (MHz) | Reading (dBuV) | Correct (dB/m) | Result (dBuV/m) | Limit (dBuV/m) | Margin (dB) | Remark |
|-----|-----------------|----------------|----------------|-----------------|----------------|-------------|--------|
| 1 | 8226.500 | 37.15 | 9.79 | 46.94 | 74.00 | -27.06 | peak |
| 2 | 9475.000 | 36.47 | 11.56 | 48.03 | 74.00 | -25.97 | peak |
| 3 | 11752.000 | 33.29 | 18.23 | 51.52 | 74.00 | -22.48 | peak |
| 4 | 12610.000 | 34.64 | 18.16 | 52.80 | 74.00 | -21.20 | peak |
| 5 | 13858.500 | 31.95 | 19.83 | 51.78 | 74.00 | -22.22 | peak |
| 6 | 17659.000 | 29.30 | 22.71 | 52.01 | 74.00 | -21.99 | peak |

- Note:
1. Measurement = Reading Level + Correct Factor.
 2. If Peak Result complies with AV limit, AV Result is deemed to comply with AV limit.
 3. Peak: Peak detector.
 4. AVG: $VBW=1/T_{on}$, where: T_{on} is the transmitting duration.
 5. For the transmitting duration, please refer to clause 7.1.
 6. Filter losses were only considered in the spurious frequency bands and the authorized band was not corrected for High Pass Filter losses.
 7. Proper operation of the transmitter prior to adding the filter to the measurement chain.
 8. Since non-restricted band peak emissions are less than the average limit, they also comply with the -27dBm/MHz (68.2dBuV/m) limit.



HARMONICS AND SPURIOUS EMISSIONS (VERTICAL)

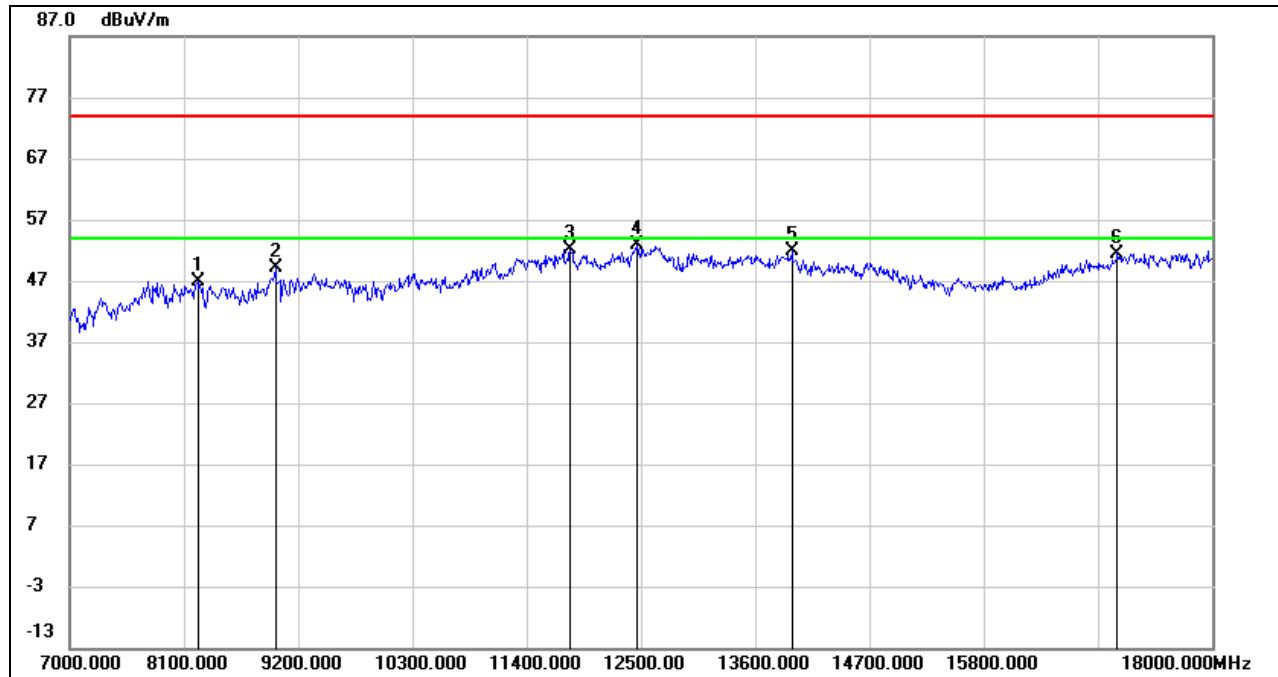

| No. | Frequency (MHz) | Reading (dBuV) | Correct (dB/m) | Result (dBuV/m) | Limit (dBuV/m) | Margin (dB) | Remark |
|-----|-----------------|----------------|----------------|-----------------|----------------|-------------|--------|
| 1 | 8232.000 | 37.16 | 9.77 | 46.93 | 74.00 | -27.07 | peak |
| 2 | 8985.500 | 37.98 | 11.07 | 49.05 | 74.00 | -24.95 | peak |
| 3 | 11818.000 | 33.71 | 18.41 | 52.12 | 74.00 | -21.88 | peak |
| 4 | 12467.000 | 34.72 | 18.04 | 52.76 | 74.00 | -21.24 | peak |
| 5 | 13952.000 | 32.29 | 19.67 | 51.96 | 74.00 | -22.04 | peak |
| 6 | 17092.500 | 31.14 | 20.36 | 51.50 | 74.00 | -22.50 | peak |

- Note:
1. Measurement = Reading Level + Correct Factor.
 2. If Peak Result complies with AV limit, AV Result is deemed to comply with AV limit.
 3. Peak: Peak detector.
 4. AVG: $VBW=1/Ton$, where: Ton is the transmitting duration.
 5. For the transmitting duration, please refer to clause 7.1.
 6. Filter losses were only considered in the spurious frequency bands and the authorized band was not corrected for High Pass Filter losses.
 7. Proper operation of the transmitter prior to adding the filter to the measurement chain.
 8. Since non-restricted band peak emissions are less than the average limit, they also comply with the -27dBm/MHz (68.2dBuV/m) limit.



UNII-3 BAND

HARMONICS AND SPURIOUS EMISSIONS (LOW CHANNEL, HORIZONTAL)

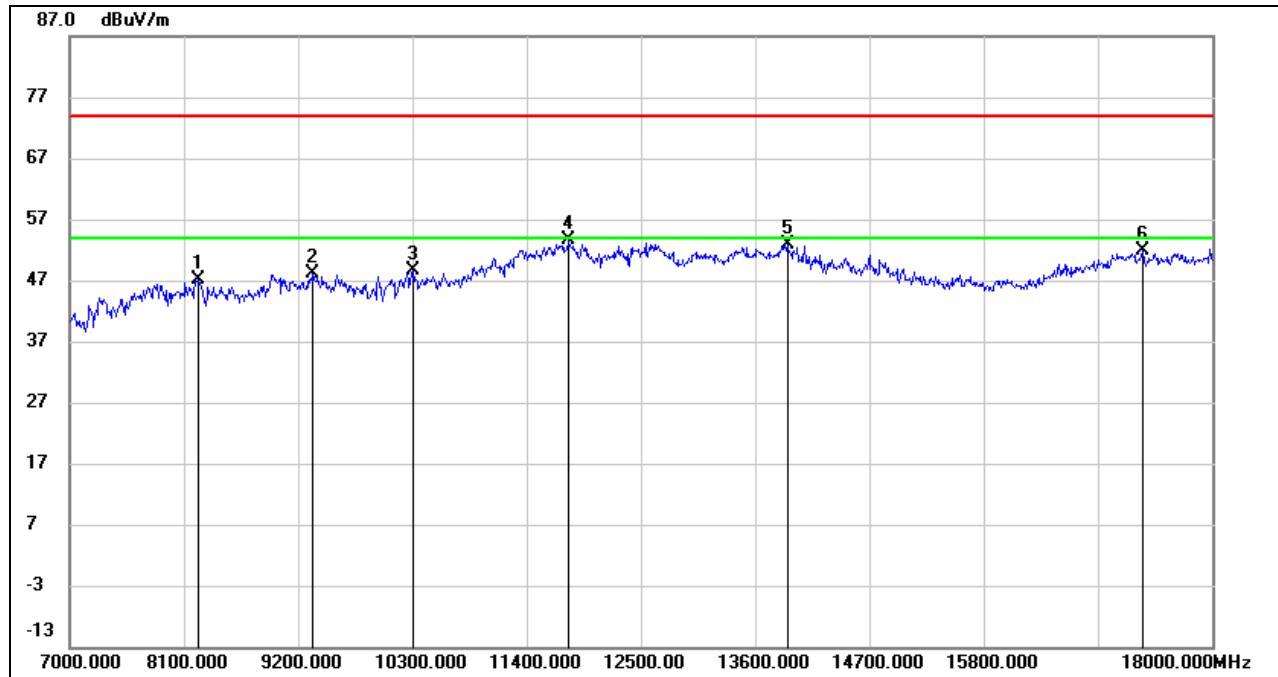

| No. | Frequency (MHz) | Reading (dBuV) | Correct (dB/m) | Result (dBuV/m) | Limit (dBuV/m) | Margin (dB) | Remark |
|-----|-----------------|----------------|----------------|-----------------|----------------|-------------|--------|
| 1 | 8243.000 | 37.33 | 9.72 | 47.05 | 74.00 | -26.95 | peak |
| 2 | 9343.000 | 37.11 | 10.97 | 48.08 | 74.00 | -25.92 | peak |
| 3 | 10311.000 | 35.75 | 12.79 | 48.54 | 74.00 | -25.46 | peak |
| 4 | 11807.000 | 35.10 | 18.44 | 53.54 | 74.00 | -20.46 | peak |
| 5 | 13908.000 | 33.05 | 19.75 | 52.80 | 74.00 | -21.20 | peak |
| 6 | 17334.500 | 30.74 | 21.02 | 51.76 | 74.00 | -22.24 | peak |

- Note:
1. Measurement = Reading Level + Correct Factor.
 2. If Peak Result complies with AV limit, AV Result is deemed to comply with AV limit.
 3. Peak: Peak detector.
 4. AVG: $VBW=1/Ton$, where: Ton is the transmitting duration.
 5. For the transmitting duration, please refer to clause 7.1.
 6. Filter losses were only considered in the spurious frequency bands and the authorized band was not corrected for High Pass Filter losses.
 7. Proper operation of the transmitter prior to adding the filter to the measurement chain.
 8. Since non-restricted band peak emissions are less than the average limit, they also comply with the -27dBm/MHz (68.2dBuV/m) limit.

HARMONICS AND SPURIOUS EMISSIONS (LOW CHANNEL, VERTICAL)

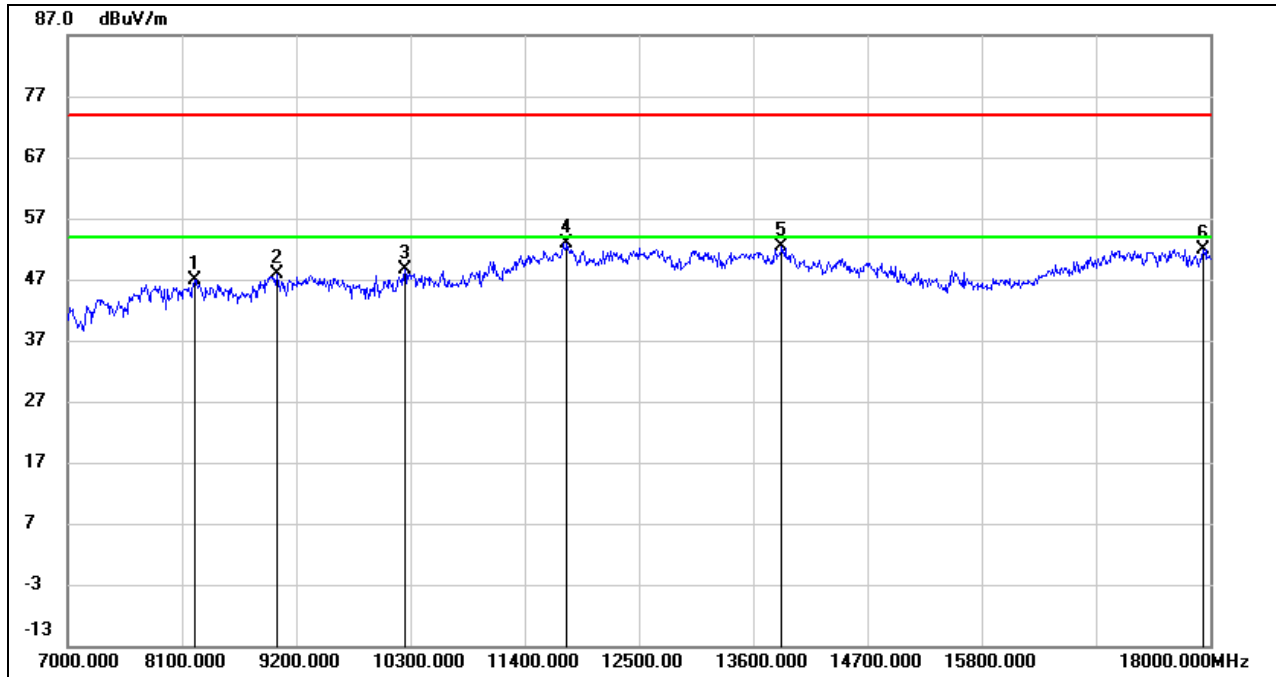

| No. | Frequency (MHz) | Reading (dBuV) | Correct (dB/m) | Result (dBuV/m) | Limit (dBuV/m) | Margin (dB) | Remark |
|-----|-----------------|----------------|----------------|-----------------|----------------|-------------|--------|
| 1 | 8226.500 | 37.18 | 9.79 | 46.97 | 74.00 | -27.03 | peak |
| 2 | 9018.500 | 36.70 | 11.13 | 47.83 | 74.00 | -26.17 | peak |
| 3 | 10250.500 | 36.00 | 12.53 | 48.53 | 74.00 | -25.47 | peak |
| 4 | 11812.500 | 34.51 | 18.43 | 52.94 | 74.00 | -21.06 | peak |
| 5 | 13875.000 | 32.63 | 19.81 | 52.44 | 74.00 | -21.56 | peak |
| 6 | 17939.500 | 27.45 | 24.53 | 51.98 | 74.00 | -22.02 | peak |

- Note: 1. Measurement = Reading Level + Correct Factor.
 2. If Peak Result complies with AV limit, AV Result is deemed to comply with AV limit.
 3. Peak: Peak detector.
 4. AVG: $VBW=1/Ton$, where: Ton is the transmitting duration.
 5. For the transmitting duration, please refer to clause 7.1.
 6. Filter losses were only considered in the spurious frequency bands and the authorized band was not corrected for High Pass Filter losses.
 7. Proper operation of the transmitter prior to adding the filter to the measurement chain.
 8. Since non-restricted band peak emissions are less than the average limit, they also comply with the -27dBm/MHz (68.2dBuV/m) limit.



HARMONICS AND SPURIOUS EMISSIONS (MID CHANNEL, HORIZONTAL)

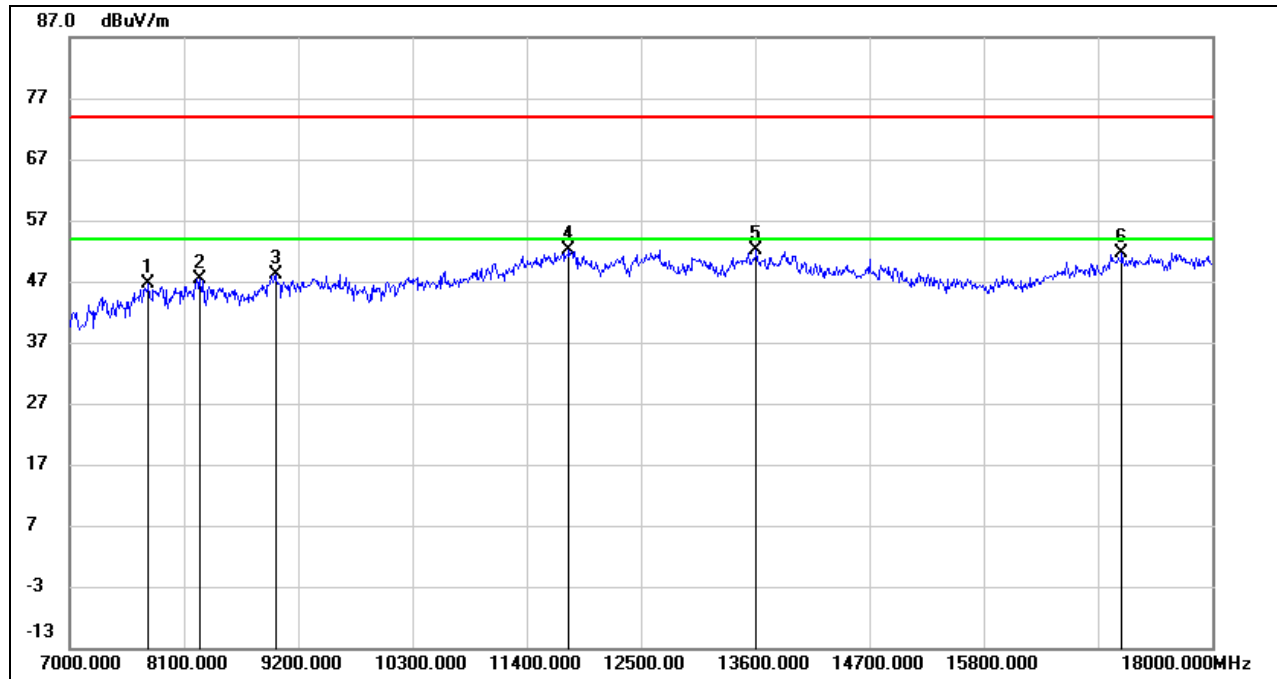

| No. | Frequency (MHz) | Reading (dBuV) | Correct (dB/m) | Result (dBuV/m) | Limit (dBuV/m) | Margin (dB) | Remark |
|-----|-----------------|----------------|----------------|-----------------|----------------|-------------|--------|
| 1 | 7764.500 | 37.81 | 8.70 | 46.51 | 74.00 | -27.49 | peak |
| 2 | 8259.500 | 37.77 | 9.67 | 47.44 | 74.00 | -26.56 | peak |
| 3 | 8985.500 | 37.09 | 11.07 | 48.16 | 74.00 | -25.84 | peak |
| 4 | 11812.500 | 33.69 | 18.43 | 52.12 | 74.00 | -21.88 | peak |
| 5 | 13616.500 | 32.63 | 19.41 | 52.04 | 74.00 | -21.96 | peak |
| 6 | 17136.500 | 30.88 | 20.69 | 51.57 | 74.00 | -22.43 | peak |

- Note:
1. Measurement = Reading Level + Correct Factor.
 2. If Peak Result complies with AV limit, AV Result is deemed to comply with AV limit.
 3. Peak: Peak detector.
 4. AVG: $VBW=1/Ton$, where: Ton is the transmitting duration.
 5. For the transmitting duration, please refer to clause 7.1.
 6. Filter losses were only considered in the spurious frequency bands and the authorized band was not corrected for High Pass Filter losses.
 7. Proper operation of the transmitter prior to adding the filter to the measurement chain.
 8. Since non-restricted band peak emissions are less than the average limit, they also comply with the -27dBm/MHz (68.2dBuV/m) limit.

HARMONICS AND SPURIOUS EMISSIONS (MID CHANNEL, VERTICAL)

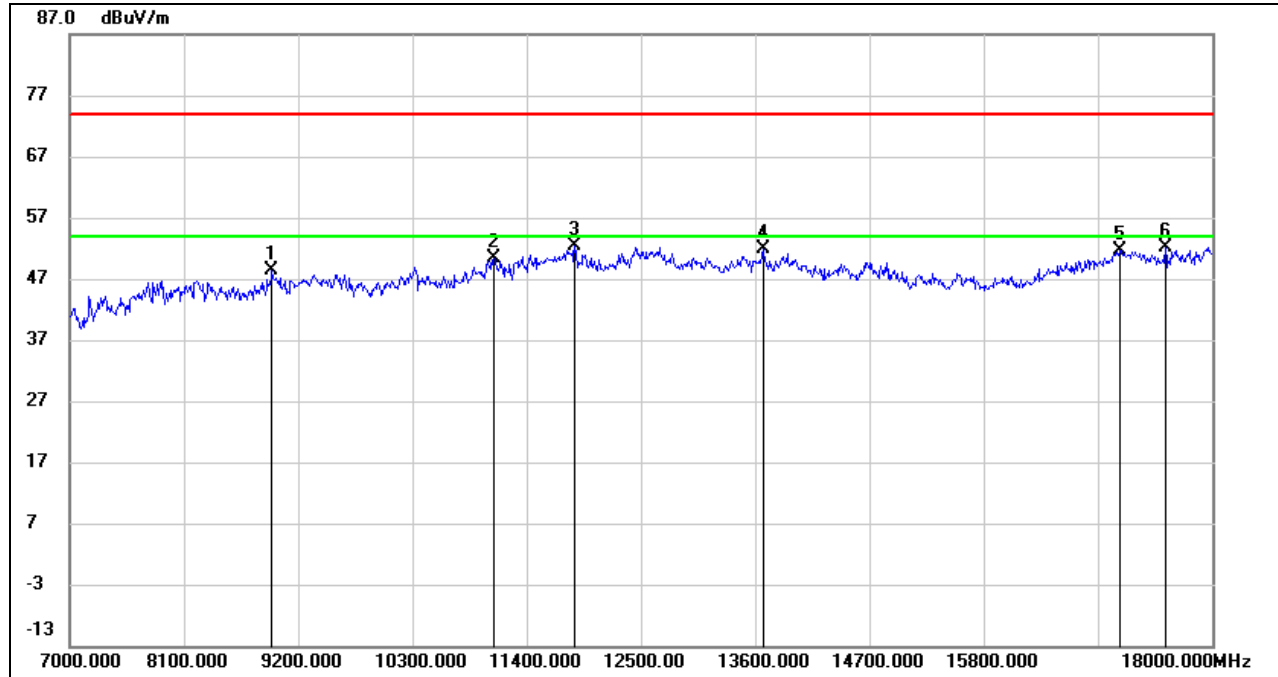

| No. | Frequency (MHz) | Reading (dBuV) | Correct (dB/m) | Result (dBuV/m) | Limit (dBuV/m) | Margin (dB) | Remark |
|-----|-----------------|----------------|----------------|-----------------|----------------|-------------|--------|
| 1 | 8947.000 | 37.71 | 10.69 | 48.40 | 74.00 | -25.60 | peak |
| 2 | 11086.500 | 34.67 | 15.69 | 50.36 | 74.00 | -23.64 | peak |
| 3 | 11867.500 | 34.01 | 18.36 | 52.37 | 74.00 | -21.63 | peak |
| 4 | 13682.500 | 32.26 | 19.61 | 51.87 | 74.00 | -22.13 | peak |
| 5 | 17114.500 | 31.21 | 20.53 | 51.74 | 74.00 | -22.26 | peak |
| 6 | 17554.500 | 30.44 | 21.80 | 52.24 | 74.00 | -21.76 | peak |

- Note:
1. Measurement = Reading Level + Correct Factor.
 2. If Peak Result complies with AV limit, AV Result is deemed to comply with AV limit.
 3. Peak: Peak detector.
 4. AVG: $VBW=1/Ton$, where: Ton is the transmitting duration.
 5. For the transmitting duration, please refer to clause 7.1.
 6. Filter losses were only considered in the spurious frequency bands and the authorized band was not corrected for High Pass Filter losses.
 7. Proper operation of the transmitter prior to adding the filter to the measurement chain.
 8. Since non-restricted band peak emissions are less than the average limit, they also comply with the -27dBm/MHz (68.2dBuV/m) limit.



HARMONICS AND SPURIOUS EMISSIONS (HIGH CHANNEL, HORIZONTAL)

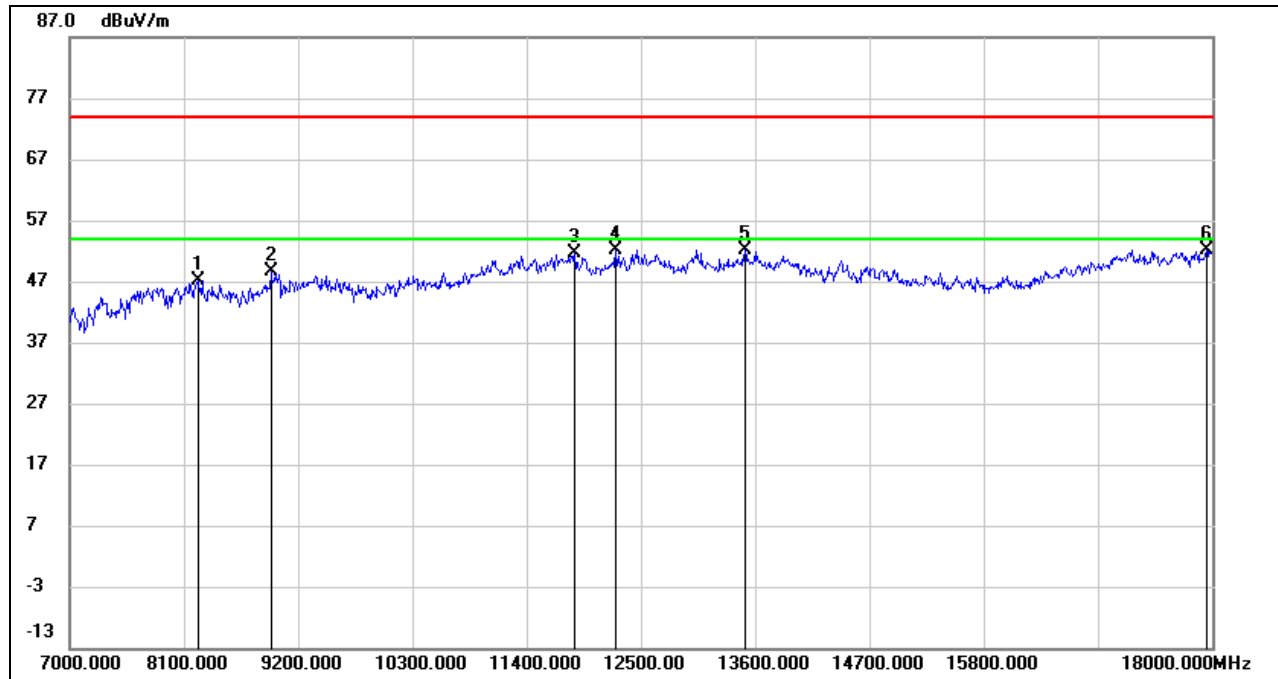

| No. | Frequency (MHz) | Reading (dBuV) | Correct (dB/m) | Result (dBuV/m) | Limit (dBuV/m) | Margin (dB) | Remark |
|-----|-----------------|----------------|----------------|-----------------|----------------|-------------|--------|
| 1 | 8232.000 | 37.36 | 9.77 | 47.13 | 74.00 | -26.87 | peak |
| 2 | 8941.500 | 37.90 | 10.63 | 48.53 | 74.00 | -25.47 | peak |
| 3 | 11867.500 | 33.25 | 18.36 | 51.61 | 74.00 | -22.39 | peak |
| 4 | 12263.500 | 34.20 | 17.96 | 52.16 | 74.00 | -21.84 | peak |
| 5 | 13501.000 | 32.66 | 19.47 | 52.13 | 74.00 | -21.87 | peak |
| 6 | 17945.000 | 27.58 | 24.54 | 52.12 | 74.00 | -21.88 | peak |

- Note:
1. Measurement = Reading Level + Correct Factor.
 2. If Peak Result complies with AV limit, AV Result is deemed to comply with AV limit.
 3. Peak: Peak detector.
 4. AVG: $VBW=1/Ton$, where: Ton is the transmitting duration.
 5. For the transmitting duration, please refer to clause 7.1.
 6. Filter losses were only considered in the spurious frequency bands and the authorized band was not corrected for High Pass Filter losses.
 7. Proper operation of the transmitter prior to adding the filter to the measurement chain.
 8. Since non-restricted band peak emissions are less than the average limit, they also comply with the -27dBm/MHz (68.2dBuV/m) limit.



HARMONICS AND SPURIOUS EMISSIONS (HIGH CHANNEL, VERTICAL)

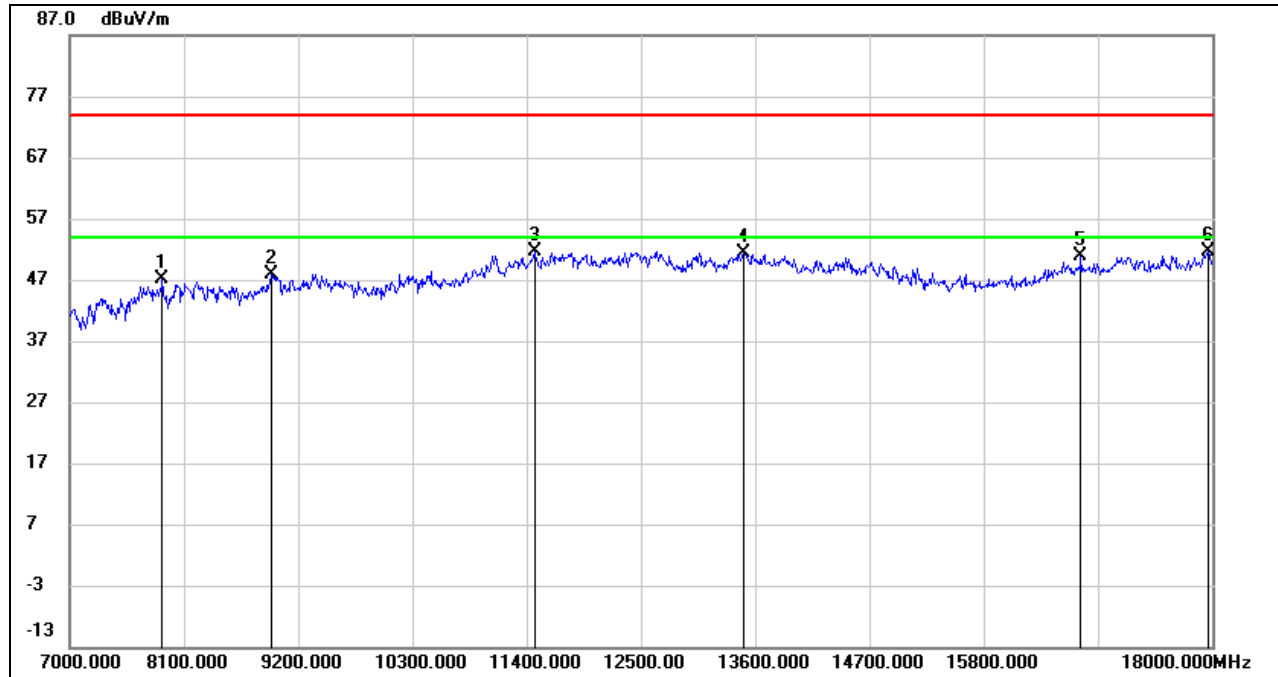

| No. | Frequency (MHz) | Reading (dBuV) | Correct (dB/m) | Result (dBuV/m) | Limit (dBuV/m) | Margin (dB) | Remark |
|-----|-----------------|----------------|----------------|-----------------|----------------|-------------|--------|
| 1 | 7891.000 | 38.52 | 8.61 | 47.13 | 74.00 | -26.87 | peak |
| 2 | 8936.000 | 37.37 | 10.57 | 47.94 | 74.00 | -26.06 | peak |
| 3 | 11477.000 | 34.35 | 17.32 | 51.67 | 74.00 | -22.33 | peak |
| 4 | 13495.500 | 31.86 | 19.46 | 51.32 | 74.00 | -22.68 | peak |
| 5 | 16740.500 | 32.13 | 18.86 | 50.99 | 74.00 | -23.01 | peak |
| 6 | 17967.000 | 27.10 | 24.61 | 51.71 | 74.00 | -22.29 | peak |

- Note:
1. Measurement = Reading Level + Correct Factor.
 2. If Peak Result complies with AV limit, AV Result is deemed to comply with AV limit.
 3. Peak: Peak detector.
 4. AVG: $VBW=1/Ton$, where: Ton is the transmitting duration.
 5. For the transmitting duration, please refer to clause 7.1.
 6. Filter losses were only considered in the spurious frequency bands and the authorized band was not corrected for High Pass Filter losses.
 7. Proper operation of the transmitter prior to adding the filter to the measurement chain.
 8. Since non-restricted band peak emissions are less than the average limit, they also comply with the -27dBm/MHz (68.2dBuV/m) limit.

8.3.3. 802.11n HT40 MIMO MODE

UNII-1 BAND

HARMONICS AND SPURIOUS EMISSIONS (LOW CHANNEL, HORIZONTAL)

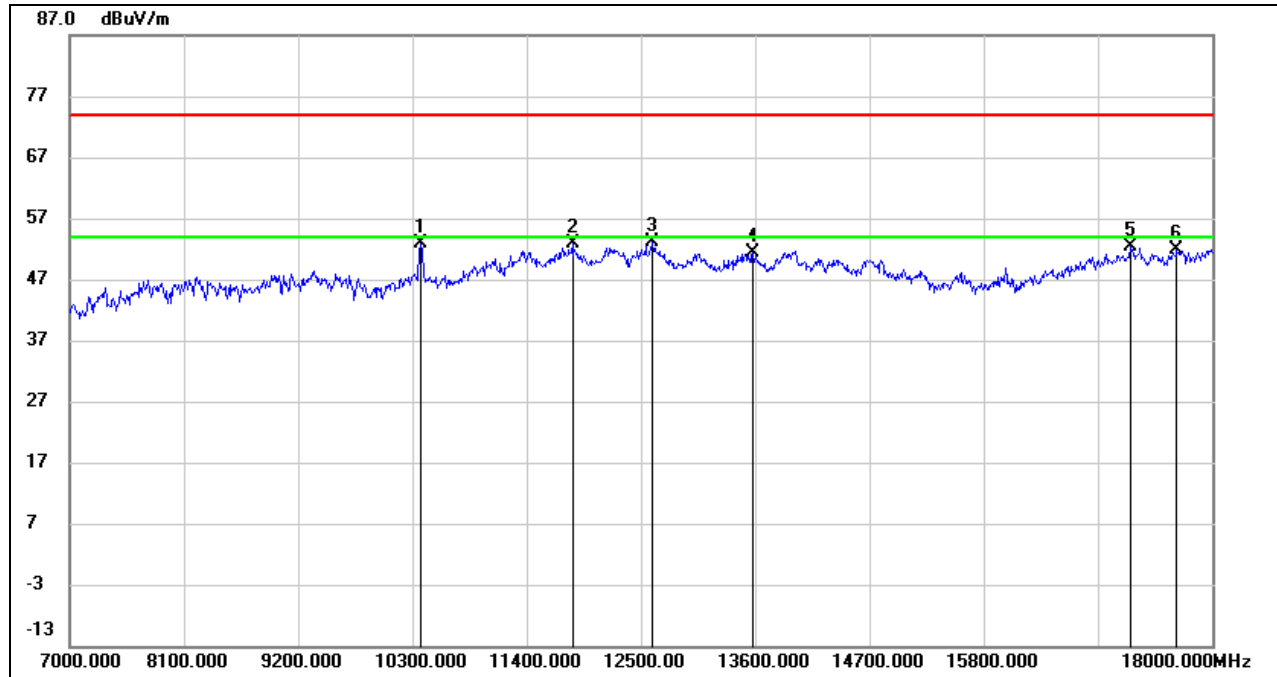

| No. | Frequency (MHz) | Reading (dBuV) | Correct (dB/m) | Result (dBuV/m) | Limit (dBuV/m) | Margin (dB) | Remark |
|-----|-----------------|----------------|----------------|-----------------|----------------|-------------|--------|
| 1 | 10377.000 | 39.88 | 13.05 | 52.93 | 74.00 | -21.07 | peak |
| 2 | 11840.000 | 34.43 | 18.39 | 52.82 | 74.00 | -21.18 | peak |
| 3 | 12610.000 | 34.93 | 18.16 | 53.09 | 74.00 | -20.91 | peak |
| 4 | 13578.000 | 31.94 | 19.39 | 51.33 | 74.00 | -22.67 | peak |
| 5 | 17219.000 | 31.21 | 21.14 | 52.35 | 74.00 | -21.65 | peak |
| 6 | 17659.000 | 29.11 | 22.71 | 51.82 | 74.00 | -22.18 | peak |

- Note:
1. Measurement = Reading Level + Correct Factor.
 2. If Peak Result complies with AV limit, AV Result is deemed to comply with AV limit.
 3. Peak: Peak detector.
 4. AVG: $VBW=1/Ton$, where: Ton is the transmitting duration.
 5. For the transmitting duration, please refer to clause 7.1.
 6. Filter losses were only considered in the spurious frequency bands and the authorized band was not corrected for High Pass Filter losses.
 7. Proper operation of the transmitter prior to adding the filter to the measurement chain.
 8. Since non-restricted band peak emissions are less than the average limit, they also comply with the -27dBm/MHz (68.2dBuV/m) limit.

HARMONICS AND SPURIOUS EMISSIONS (LOW CHANNEL, VERTICAL)

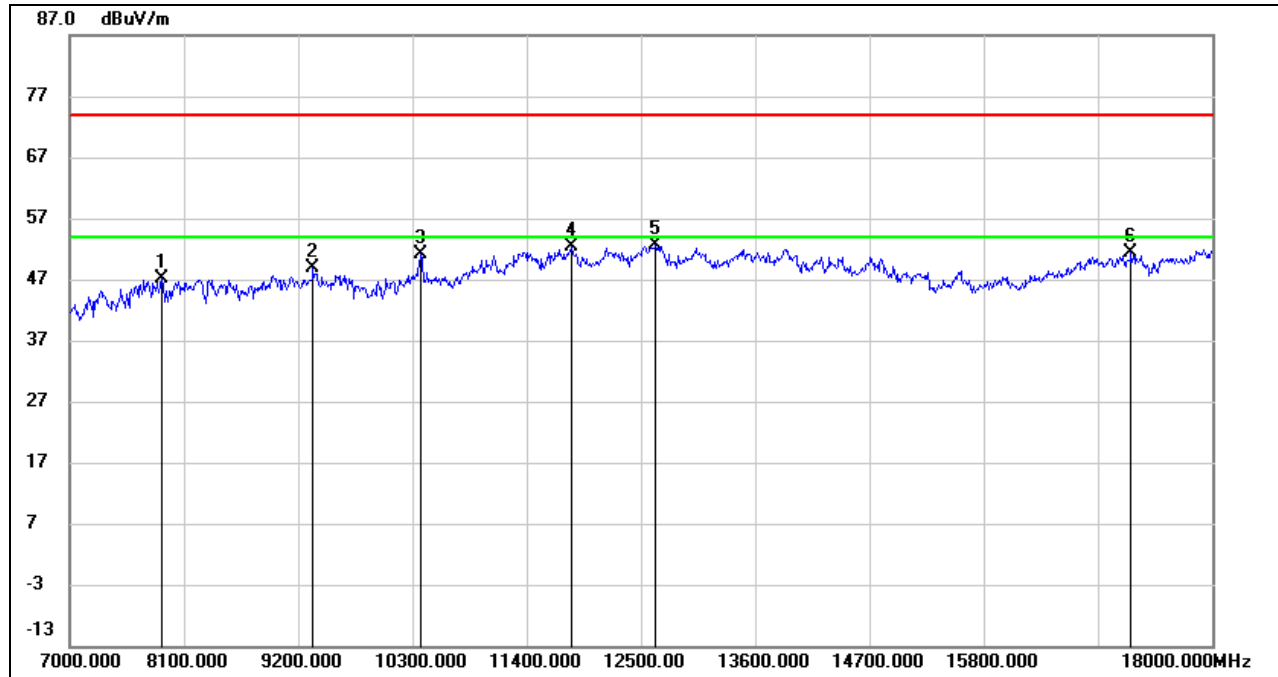

| No. | Frequency (MHz) | Reading (dBuV) | Correct (dB/m) | Result (dBuV/m) | Limit (dBuV/m) | Margin (dB) | Remark |
|-----|-----------------|----------------|----------------|-----------------|----------------|-------------|--------|
| 1 | 7880.000 | 38.54 | 8.64 | 47.18 | 74.00 | -26.82 | peak |
| 2 | 9343.000 | 37.88 | 10.97 | 48.85 | 74.00 | -25.15 | peak |
| 3 | 10377.000 | 38.18 | 13.05 | 51.23 | 74.00 | -22.77 | peak |
| 4 | 11829.000 | 34.05 | 18.40 | 52.45 | 74.00 | -21.55 | peak |
| 5 | 12643.000 | 34.38 | 18.18 | 52.56 | 74.00 | -21.44 | peak |
| 6 | 17219.000 | 30.20 | 21.14 | 51.34 | 74.00 | -22.66 | peak |

- Note: 1. Measurement = Reading Level + Correct Factor.
 2. If Peak Result complies with AV limit, AV Result is deemed to comply with AV limit.
 3. Peak: Peak detector.
 4. AVG: $VBW=1/Ton$, where: Ton is the transmitting duration.
 5. For the transmitting duration, please refer to clause 7.1.
 6. Filter losses were only considered in the spurious frequency bands and the authorized band was not corrected for High Pass Filter losses.
 7. Proper operation of the transmitter prior to adding the filter to the measurement chain.
 8. Since non-restricted band peak emissions are less than the average limit, they also comply with the -27dBm/MHz (68.2dBuV/m) limit.



HARMONICS AND SPURIOUS EMISSIONS (HIGH CHANNEL, HORIZONTAL)

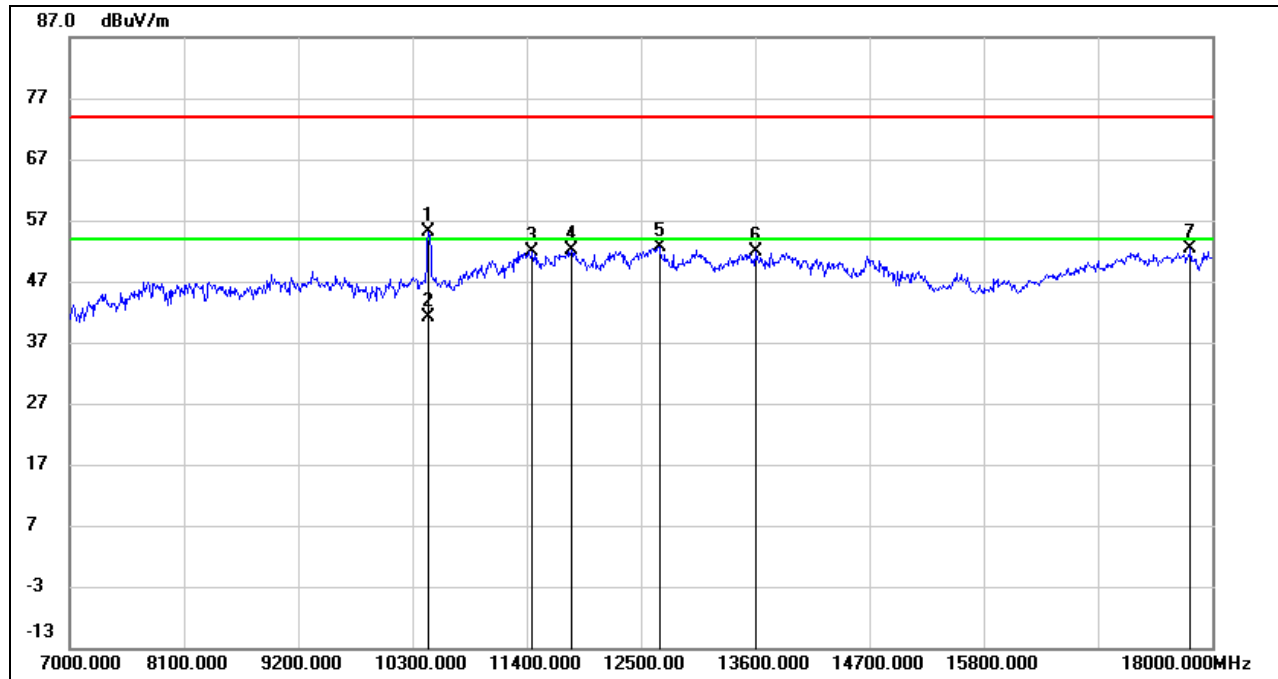

| No. | Frequency (MHz) | Reading (dBuV) | Correct (dB/m) | Result (dBuV/m) | Limit (dBuV/m) | Margin (dB) | Remark |
|-----|-----------------|----------------|----------------|-----------------|----------------|-------------|--------|
| 1 | 10454.000 | 41.66 | 13.39 | 55.05 | 74.00 | -18.95 | peak |
| 2 | 10454.000 | 27.86 | 13.39 | 41.25 | 54.00 | -12.75 | AVG |
| 3 | 11455.000 | 34.63 | 17.24 | 51.87 | 74.00 | -22.13 | peak |
| 4 | 11829.000 | 33.81 | 18.40 | 52.21 | 74.00 | -21.79 | peak |
| 5 | 12676.000 | 34.53 | 18.18 | 52.71 | 74.00 | -21.29 | peak |
| 6 | 13600.000 | 32.58 | 19.37 | 51.95 | 74.00 | -22.05 | peak |
| 7 | 17791.000 | 28.28 | 24.00 | 52.28 | 74.00 | -21.72 | peak |

- Note: 1. Measurement = Reading Level + Correct Factor.
 2. If Peak Result complies with AV limit, AV Result is deemed to comply with AV limit.
 3. Peak: Peak detector.
 4. AVG: $VBW=1/Ton$, where: Ton is the transmitting duration.
 5. For the transmitting duration, please refer to clause 7.1.
 6. Filter losses were only considered in the spurious frequency bands and the authorized band was not corrected for High Pass Filter losses.
 7. Proper operation of the transmitter prior to adding the filter to the measurement chain.
 8. Since non-restricted band peak emissions are less than the average limit, they also comply with the -27dBm/MHz (68.2dBuV/m) limit.



HARMONICS AND SPURIOUS EMISSIONS (HIGH CHANNEL, VERTICAL)

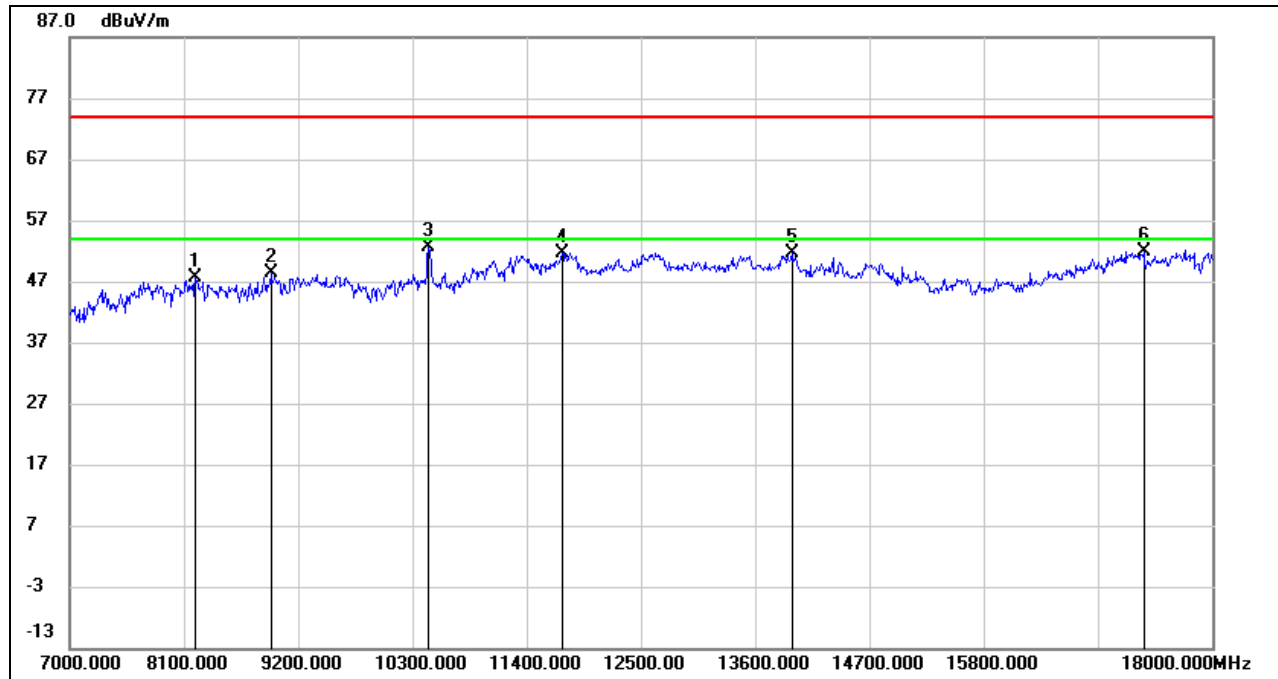

| No. | Frequency (MHz) | Reading (dBuV) | Correct (dB/m) | Result (dBuV/m) | Limit (dBuV/m) | Margin (dB) | Remark |
|-----|-----------------|----------------|----------------|-----------------|----------------|-------------|--------|
| 1 | 8210.000 | 37.84 | 9.86 | 47.70 | 74.00 | -26.30 | peak |
| 2 | 8936.000 | 37.82 | 10.57 | 48.39 | 74.00 | -25.61 | peak |
| 3 | 10454.000 | 39.33 | 13.39 | 52.72 | 74.00 | -21.28 | peak |
| 4 | 11741.000 | 33.49 | 18.18 | 51.67 | 74.00 | -22.33 | peak |
| 5 | 13952.000 | 31.87 | 19.67 | 51.54 | 74.00 | -22.46 | peak |
| 6 | 17340.000 | 30.96 | 21.01 | 51.97 | 74.00 | -22.03 | peak |

- Note: 1. Measurement = Reading Level + Correct Factor.
 2. If Peak Result complies with AV limit, AV Result is deemed to comply with AV limit.
 3. Peak: Peak detector.
 4. AVG: $VBW=1/Ton$, where: Ton is the transmitting duration.
 5. For the transmitting duration, please refer to clause 7.1.
 6. Filter losses were only considered in the spurious frequency bands and the authorized band was not corrected for High Pass Filter losses.
 7. Proper operation of the transmitter prior to adding the filter to the measurement chain.
 8. Since non-restricted band peak emissions are less than the average limit, they also comply with the -27dBm/MHz (68.2dBuV/m) limit.

UNII-2A BAND

HARMONICS AND SPURIOUS EMISSIONS (LOW CHANNEL, HORIZONTAL)

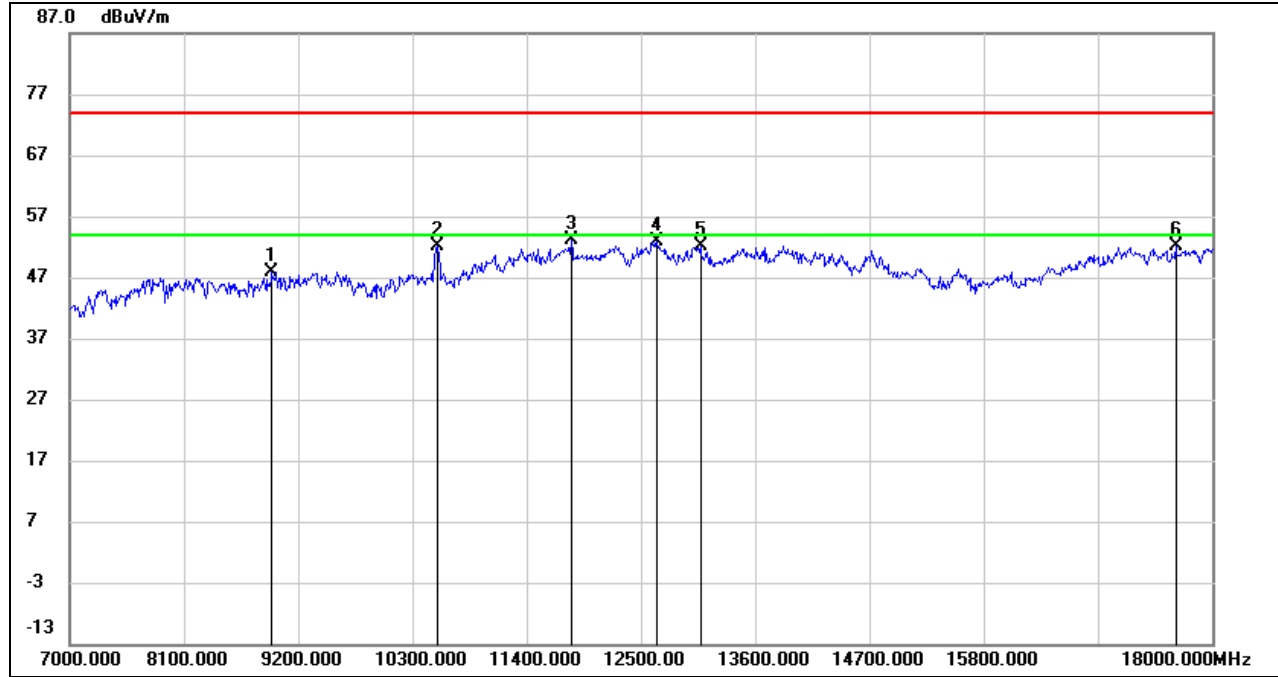

| No. | Frequency (MHz) | Reading (dBuV) | Correct (dB/m) | Result (dBuV/m) | Limit (dBuV/m) | Margin (dB) | Remark |
|-----|-----------------|----------------|----------------|-----------------|----------------|-------------|--------|
| 1 | 8947.000 | 37.27 | 10.69 | 47.96 | 74.00 | -26.04 | peak |
| 2 | 10542.000 | 38.24 | 13.78 | 52.02 | 74.00 | -21.98 | peak |
| 3 | 11829.000 | 34.74 | 18.40 | 53.14 | 74.00 | -20.86 | peak |
| 4 | 12654.000 | 34.71 | 18.17 | 52.88 | 74.00 | -21.12 | peak |
| 5 | 13072.000 | 33.81 | 18.38 | 52.19 | 74.00 | -21.81 | peak |
| 6 | 17648.000 | 29.46 | 22.61 | 52.07 | 74.00 | -21.93 | peak |

- Note:
1. Measurement = Reading Level + Correct Factor.
 2. If Peak Result complies with AV limit, AV Result is deemed to comply with AV limit.
 3. Peak: Peak detector.
 4. AVG: $VBW=1/Ton$, where: Ton is the transmitting duration.
 5. For the transmitting duration, please refer to clause 7.1.
 6. Filter losses were only considered in the spurious frequency bands and the authorized band was not corrected for High Pass Filter losses.
 7. Proper operation of the transmitter prior to adding the filter to the measurement chain.
 8. Since non-restricted band peak emissions are less than the average limit, they also comply with the -27dBm/MHz (68.2dBuV/m) limit.

HARMONICS AND SPURIOUS EMISSIONS (LOW CHANNEL, VERTICAL)

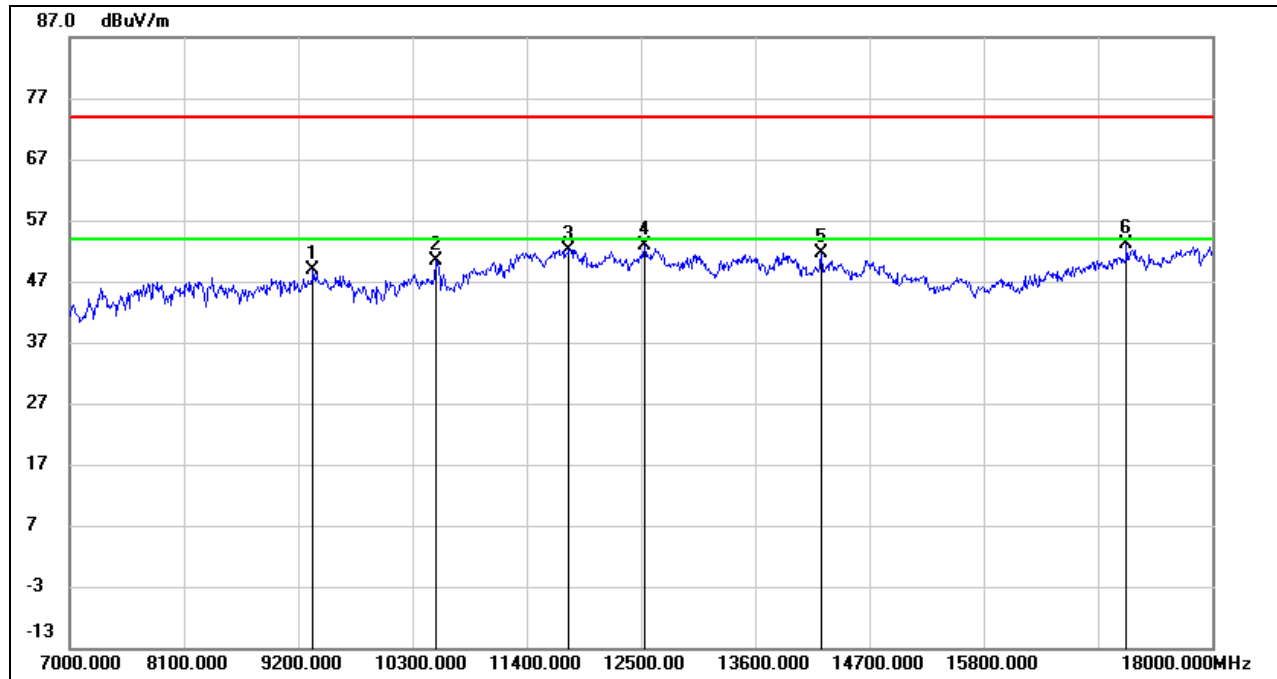

| No. | Frequency (MHz) | Reading (dBuV) | Correct (dB/m) | Result (dBuV/m) | Limit (dBuV/m) | Margin (dB) | Remark |
|-----|-----------------|----------------|----------------|-----------------|----------------|-------------|--------|
| 1 | 9343.000 | 37.97 | 10.97 | 48.94 | 74.00 | -25.06 | peak |
| 2 | 10531.000 | 36.68 | 13.73 | 50.41 | 74.00 | -23.59 | peak |
| 3 | 11807.000 | 33.79 | 18.44 | 52.23 | 74.00 | -21.77 | peak |
| 4 | 12533.000 | 34.81 | 18.07 | 52.88 | 74.00 | -21.12 | peak |
| 5 | 14238.000 | 32.72 | 18.94 | 51.66 | 74.00 | -22.34 | peak |
| 6 | 17175.000 | 32.24 | 20.98 | 53.22 | 74.00 | -20.78 | peak |

- Note: 1. Measurement = Reading Level + Correct Factor.
 2. If Peak Result complies with AV limit, AV Result is deemed to comply with AV limit.
 3. Peak: Peak detector.
 4. AVG: $VBW=1/Ton$, where: Ton is the transmitting duration.
 5. For the transmitting duration, please refer to clause 7.1.
 6. Filter losses were only considered in the spurious frequency bands and the authorized band was not corrected for High Pass Filter losses.
 7. Proper operation of the transmitter prior to adding the filter to the measurement chain.
 8. Since non-restricted band peak emissions are less than the average limit, they also comply with the -27dBm/MHz (68.2dBuV/m) limit.



HARMONICS AND SPURIOUS EMISSIONS (HIGH CHANNEL, HORIZONTAL)

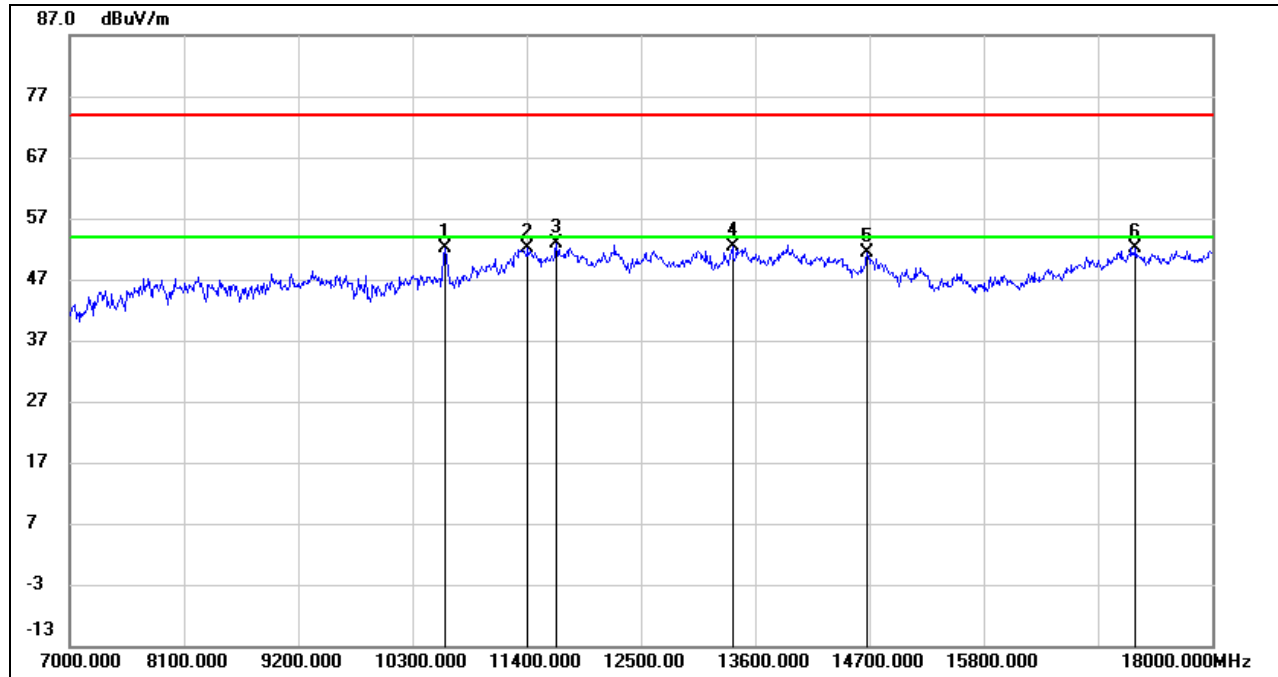

| No. | Frequency (MHz) | Reading (dBuV) | Correct (dB/m) | Result (dBuV/m) | Limit (dBuV/m) | Margin (dB) | Remark |
|-----|-----------------|----------------|----------------|-----------------|----------------|-------------|--------|
| 1 | 10608.000 | 38.01 | 14.06 | 52.07 | 74.00 | -21.93 | peak |
| 2 | 11411.000 | 35.16 | 17.08 | 52.24 | 74.00 | -21.76 | peak |
| 3 | 11686.000 | 34.85 | 17.95 | 52.80 | 74.00 | -21.20 | peak |
| 4 | 13380.000 | 33.15 | 19.23 | 52.38 | 74.00 | -21.62 | peak |
| 5 | 14678.000 | 33.81 | 17.51 | 51.32 | 74.00 | -22.68 | peak |
| 6 | 17263.000 | 31.03 | 21.11 | 52.14 | 74.00 | -21.86 | peak |

- Note:
1. Measurement = Reading Level + Correct Factor.
 2. If Peak Result complies with AV limit, AV Result is deemed to comply with AV limit.
 3. Peak: Peak detector.
 4. AVG: $VBW=1/Ton$, where: Ton is the transmitting duration.
 5. For the transmitting duration, please refer to clause 7.1.
 6. Filter losses were only considered in the spurious frequency bands and the authorized band was not corrected for High Pass Filter losses.
 7. Proper operation of the transmitter prior to adding the filter to the measurement chain.
 8. Since non-restricted band peak emissions are less than the average limit, they also comply with the -27dBm/MHz (68.2dBuV/m) limit.



HARMONICS AND SPURIOUS EMISSIONS (HIGH CHANNEL, VERTICAL)

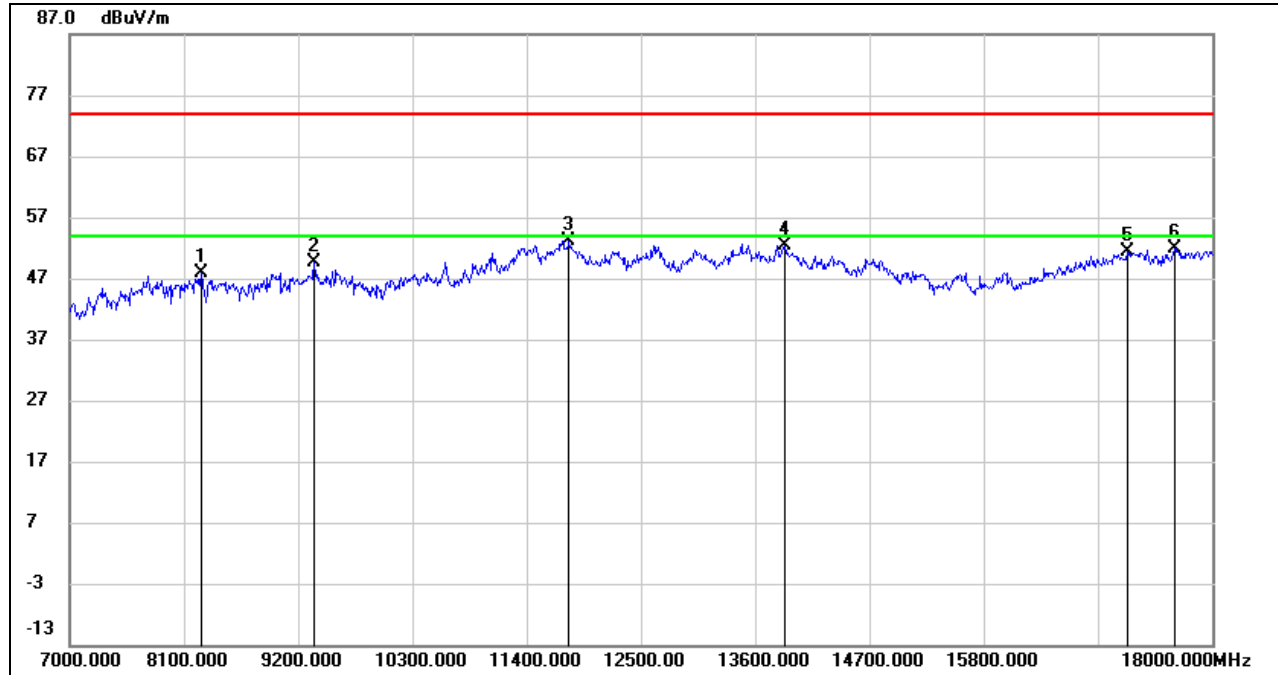

| No. | Frequency (MHz) | Reading (dBuV) | Correct (dB/m) | Result (dBuV/m) | Limit (dBuV/m) | Margin (dB) | Remark |
|-----|-----------------|----------------|----------------|-----------------|----------------|-------------|--------|
| 1 | 8265.000 | 38.13 | 9.64 | 47.77 | 74.00 | -26.23 | peak |
| 2 | 9354.000 | 38.49 | 11.02 | 49.51 | 74.00 | -24.49 | peak |
| 3 | 11807.000 | 34.60 | 18.44 | 53.04 | 74.00 | -20.96 | peak |
| 4 | 13886.000 | 32.68 | 19.79 | 52.47 | 74.00 | -21.53 | peak |
| 5 | 17186.000 | 30.43 | 21.06 | 51.49 | 74.00 | -22.51 | peak |
| 6 | 17637.000 | 29.49 | 22.50 | 51.99 | 74.00 | -22.01 | peak |

- Note:
1. Measurement = Reading Level + Correct Factor.
 2. If Peak Result complies with AV limit, AV Result is deemed to comply with AV limit.
 3. Peak: Peak detector.
 4. AVG: $VBW=1/Ton$, where: Ton is the transmitting duration.
 5. For the transmitting duration, please refer to clause 7.1.
 6. Filter losses were only considered in the spurious frequency bands and the authorized band was not corrected for High Pass Filter losses.
 7. Proper operation of the transmitter prior to adding the filter to the measurement chain.
 8. Since non-restricted band peak emissions are less than the average limit, they also comply with the -27dBm/MHz (68.2dBuV/m) limit.



UNII-2C BAND

HARMONICS AND SPURIOUS EMISSIONS (LOW CHANNEL, HORIZONTAL)

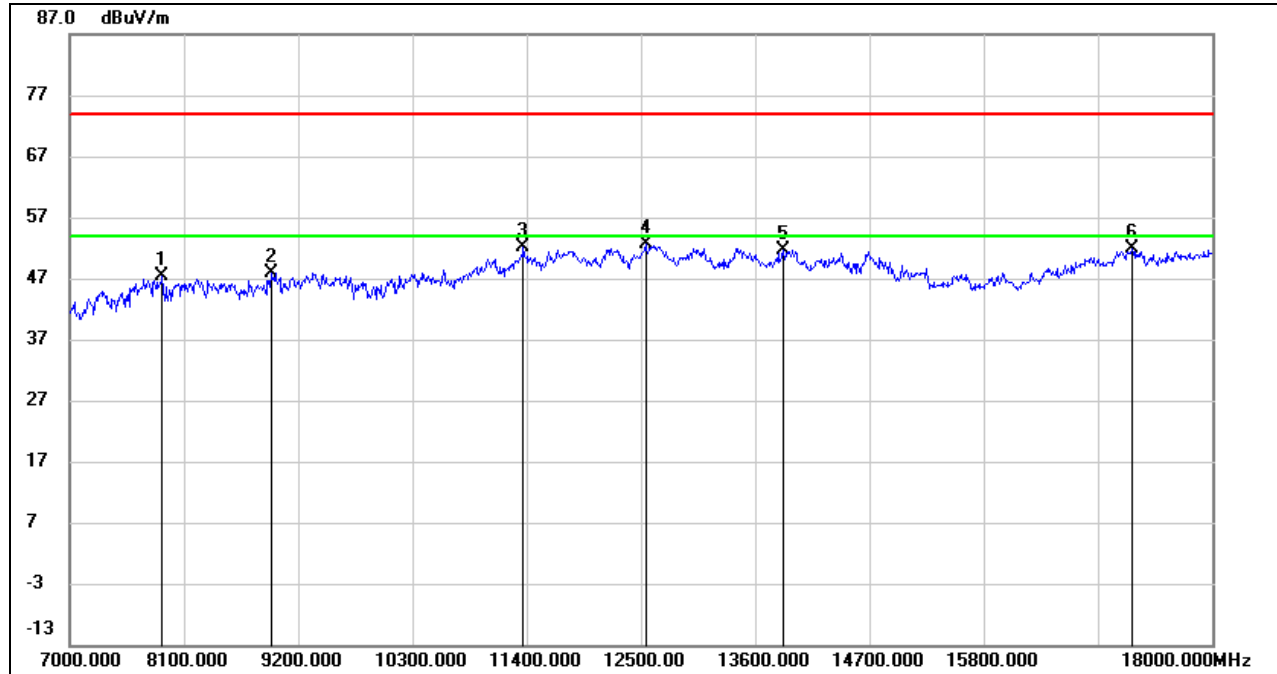

| No. | Frequency (MHz) | Reading (dBuV) | Correct (dB/m) | Result (dBuV/m) | Limit (dBuV/m) | Margin (dB) | Remark |
|-----|-----------------|----------------|----------------|-----------------|----------------|-------------|--------|
| 1 | 7891.000 | 38.85 | 8.61 | 47.46 | 74.00 | -26.54 | peak |
| 2 | 8947.000 | 37.22 | 10.69 | 47.91 | 74.00 | -26.09 | peak |
| 3 | 11367.000 | 35.12 | 16.89 | 52.01 | 74.00 | -21.99 | peak |
| 4 | 12544.000 | 34.48 | 18.08 | 52.56 | 74.00 | -21.44 | peak |
| 5 | 13875.000 | 31.85 | 19.81 | 51.66 | 74.00 | -22.34 | peak |
| 6 | 17230.000 | 30.77 | 21.13 | 51.90 | 74.00 | -22.10 | peak |

- Note:
1. Measurement = Reading Level + Correct Factor.
 2. If Peak Result complies with AV limit, AV Result is deemed to comply with AV limit.
 3. Peak: Peak detector.
 4. AVG: $VBW=1/Ton$, where: Ton is the transmitting duration.
 5. For the transmitting duration, please refer to clause 7.1.
 6. Filter losses were only considered in the spurious frequency bands and the authorized band was not corrected for High Pass Filter losses.
 7. Proper operation of the transmitter prior to adding the filter to the measurement chain.
 8. Since non-restricted band peak emissions are less than the average limit, they also comply with the -27dBm/MHz (68.2dBuV/m) limit.



HARMONICS AND SPURIOUS EMISSIONS (LOW CHANNEL, VERTICAL)

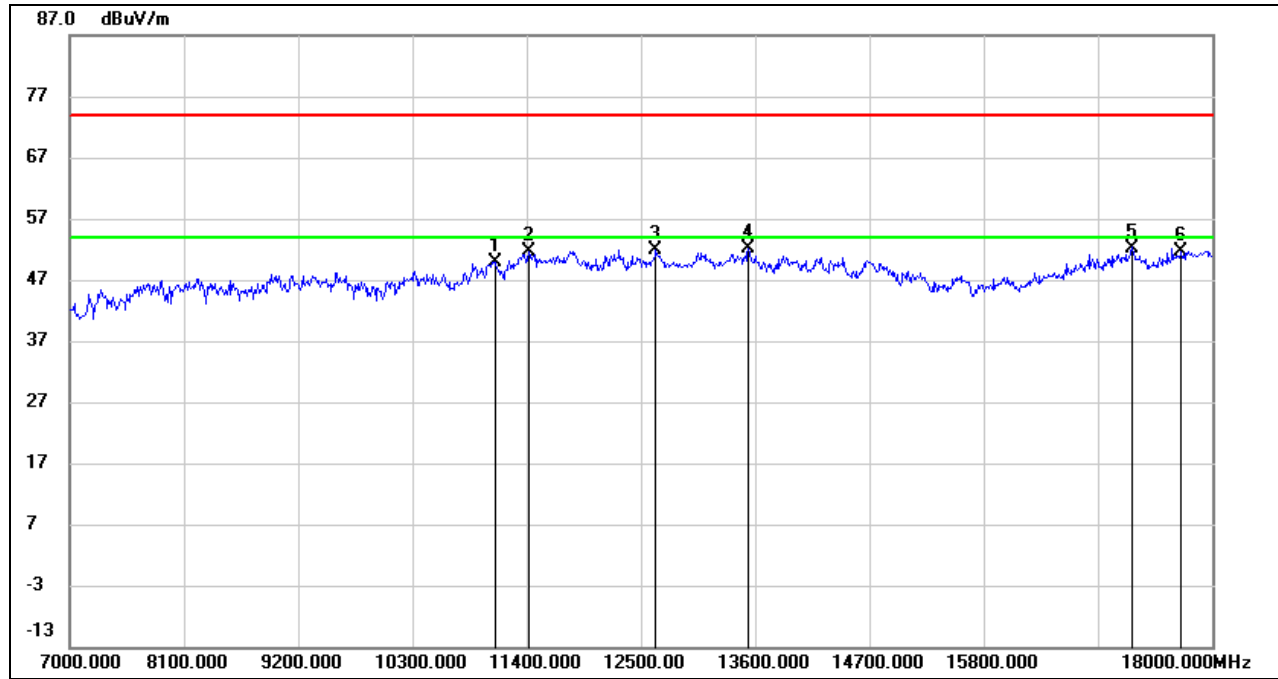

| No. | Frequency (MHz) | Reading (dBuV) | Correct (dB/m) | Result (dBuV/m) | Limit (dBuV/m) | Margin (dB) | Remark |
|-----|-----------------|----------------|----------------|-----------------|----------------|-------------|--------|
| 1 | 11092.000 | 34.28 | 15.71 | 49.99 | 74.00 | -24.01 | peak |
| 2 | 11422.000 | 34.47 | 17.13 | 51.60 | 74.00 | -22.40 | peak |
| 3 | 12643.000 | 33.70 | 18.18 | 51.88 | 74.00 | -22.12 | peak |
| 4 | 13534.000 | 32.60 | 19.44 | 52.04 | 74.00 | -21.96 | peak |
| 5 | 17230.000 | 31.12 | 21.13 | 52.25 | 74.00 | -21.75 | peak |
| 6 | 17703.000 | 28.54 | 23.14 | 51.68 | 74.00 | -22.32 | peak |

- Note:
1. Measurement = Reading Level + Correct Factor.
 2. If Peak Result complies with AV limit, AV Result is deemed to comply with AV limit.
 3. Peak: Peak detector.
 4. AVG: $VBW=1/Ton$, where: Ton is the transmitting duration.
 5. For the transmitting duration, please refer to clause 7.1.
 6. Filter losses were only considered in the spurious frequency bands and the authorized band was not corrected for High Pass Filter losses.
 7. Proper operation of the transmitter prior to adding the filter to the measurement chain.
 8. Since non-restricted band peak emissions are less than the average limit, they also comply with the -27dBm/MHz (68.2dBuV/m) limit.



HARMONICS AND SPURIOUS EMISSIONS (MID CHANNEL, HORIZONTAL)

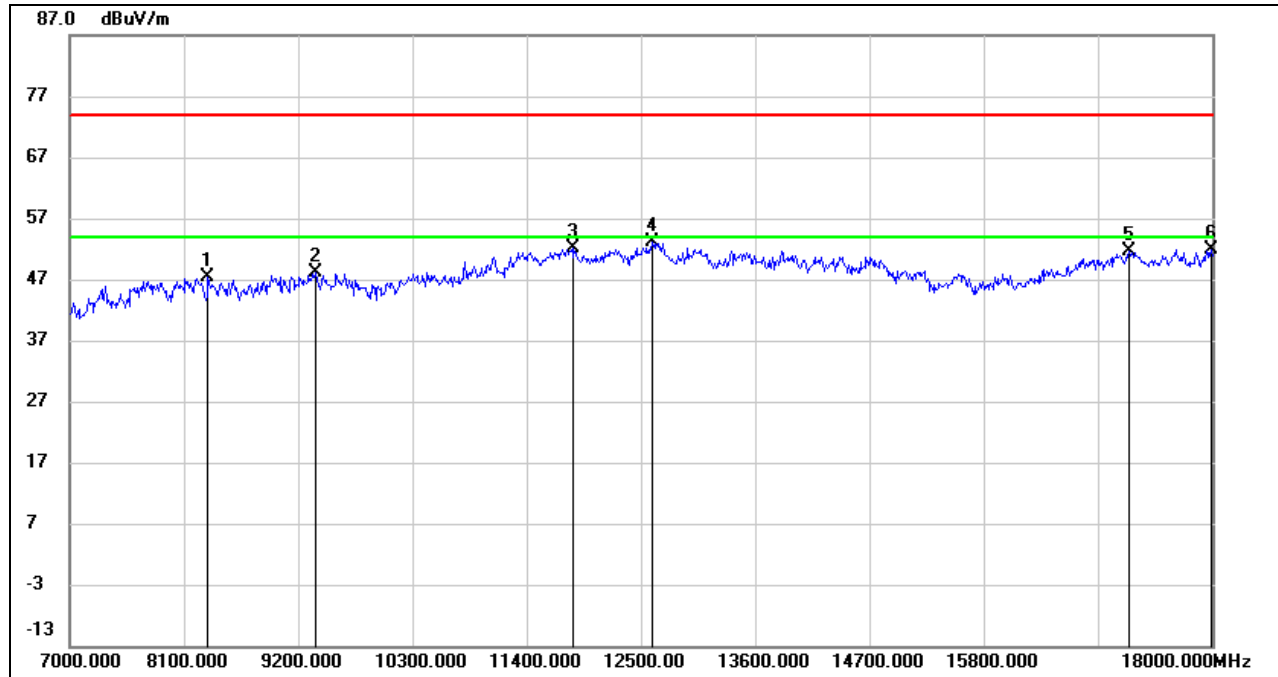

| No. | Frequency (MHz) | Reading (dBuV) | Correct (dB/m) | Result (dBuV/m) | Limit (dBuV/m) | Margin (dB) | Remark |
|-----|-----------------|----------------|----------------|-----------------|----------------|-------------|--------|
| 1 | 8331.000 | 37.95 | 9.39 | 47.34 | 74.00 | -26.66 | peak |
| 2 | 9365.000 | 36.98 | 11.08 | 48.06 | 74.00 | -25.94 | peak |
| 3 | 11840.000 | 33.68 | 18.39 | 52.07 | 74.00 | -21.93 | peak |
| 4 | 12610.000 | 34.87 | 18.16 | 53.03 | 74.00 | -20.97 | peak |
| 5 | 17197.000 | 30.41 | 21.15 | 51.56 | 74.00 | -22.44 | peak |
| 6 | 17989.000 | 27.24 | 24.68 | 51.92 | 74.00 | -22.08 | peak |

- Note:
1. Measurement = Reading Level + Correct Factor.
 2. If Peak Result complies with AV limit, AV Result is deemed to comply with AV limit.
 3. Peak: Peak detector.
 4. AVG: $VBW=1/Ton$, where: Ton is the transmitting duration.
 5. For the transmitting duration, please refer to clause 7.1.
 6. Filter losses were only considered in the spurious frequency bands and the authorized band was not corrected for High Pass Filter losses.
 7. Proper operation of the transmitter prior to adding the filter to the measurement chain.
 8. Since non-restricted band peak emissions are less than the average limit, they also comply with the -27dBm/MHz (68.2dBuV/m) limit.

HARMONICS AND SPURIOUS EMISSIONS (MID CHANNEL, VERTICAL)

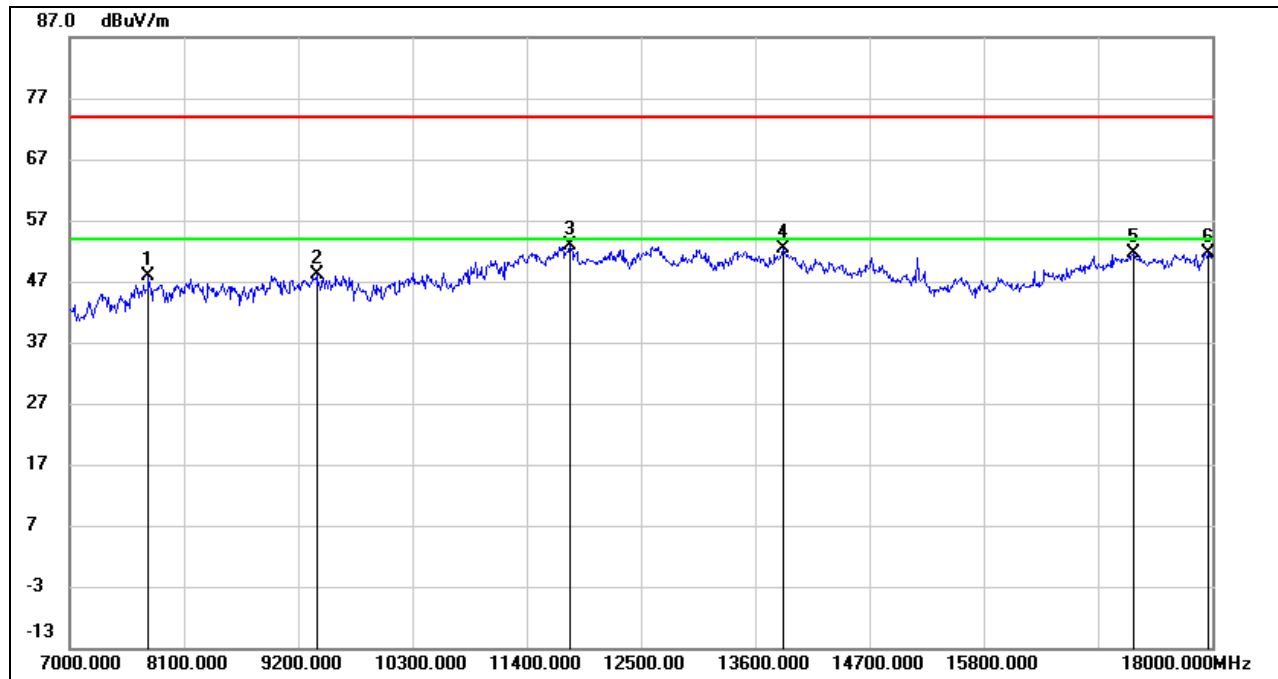

| No. | Frequency (MHz) | Reading (dBuV) | Correct (dB/m) | Result (dBuV/m) | Limit (dBuV/m) | Margin (dB) | Remark |
|-----|-----------------|----------------|----------------|-----------------|----------------|-------------|--------|
| 1 | 7759.000 | 39.21 | 8.69 | 47.90 | 74.00 | -26.10 | peak |
| 2 | 9376.000 | 36.89 | 11.14 | 48.03 | 74.00 | -25.97 | peak |
| 3 | 11818.000 | 34.37 | 18.41 | 52.78 | 74.00 | -21.22 | peak |
| 4 | 13864.000 | 32.48 | 19.81 | 52.29 | 74.00 | -21.71 | peak |
| 5 | 17241.000 | 30.39 | 21.12 | 51.51 | 74.00 | -22.49 | peak |
| 6 | 17967.000 | 27.10 | 24.61 | 51.71 | 74.00 | -22.29 | peak |

- Note: 1. Measurement = Reading Level + Correct Factor.
 2. If Peak Result complies with AV limit, AV Result is deemed to comply with AV limit.
 3. Peak: Peak detector.
 4. AVG: $VBW=1/Ton$, where: Ton is the transmitting duration.
 5. For the transmitting duration, please refer to clause 7.1.
 6. Filter losses were only considered in the spurious frequency bands and the authorized band was not corrected for High Pass Filter losses.
 7. Proper operation of the transmitter prior to adding the filter to the measurement chain.
 8. Since non-restricted band peak emissions are less than the average limit, they also comply with the -27dBm/MHz (68.2dBuV/m) limit.



HARMONICS AND SPURIOUS EMISSIONS (HIGH CHANNEL, HORIZONTAL)

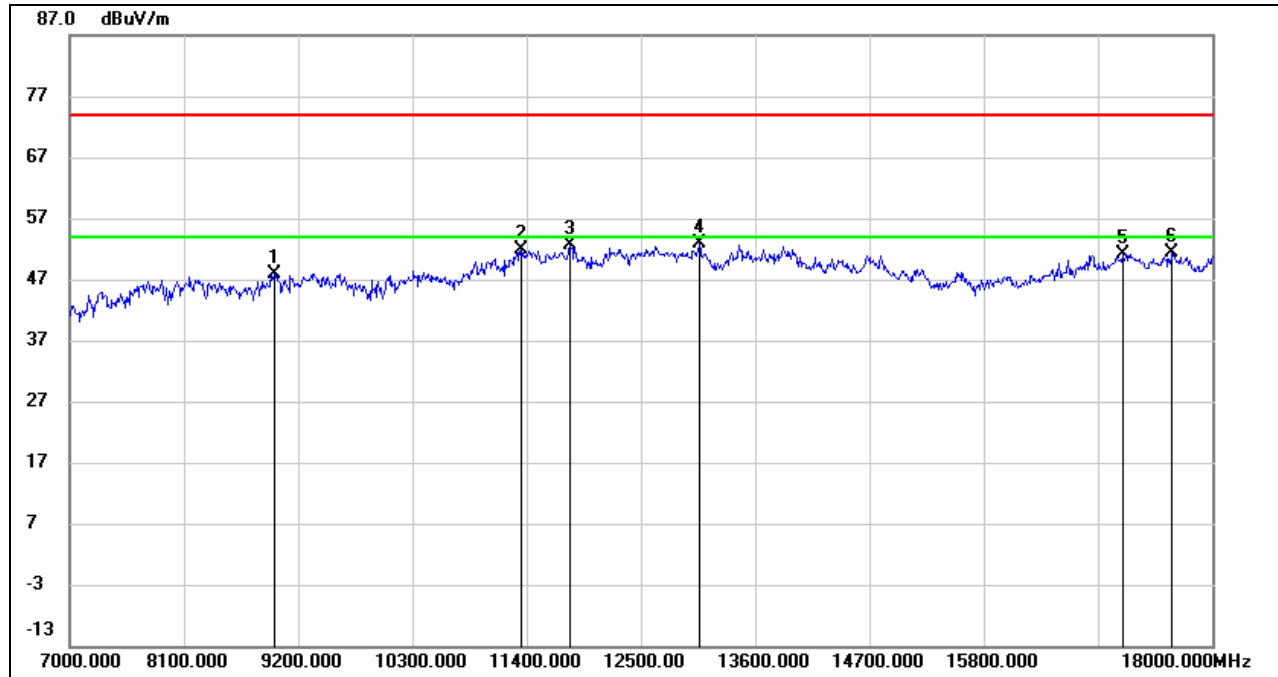

| No. | Frequency (MHz) | Reading (dBuV) | Correct (dB/m) | Result (dBuV/m) | Limit (dBuV/m) | Margin (dB) | Remark |
|-----|-----------------|----------------|----------------|-----------------|----------------|-------------|--------|
| 1 | 8969.000 | 37.05 | 10.90 | 47.95 | 74.00 | -26.05 | peak |
| 2 | 11345.000 | 35.01 | 16.81 | 51.82 | 74.00 | -22.18 | peak |
| 3 | 11818.000 | 34.12 | 18.41 | 52.53 | 74.00 | -21.47 | peak |
| 4 | 13061.000 | 34.55 | 18.38 | 52.93 | 74.00 | -21.07 | peak |
| 5 | 17142.000 | 30.47 | 20.74 | 51.21 | 74.00 | -22.79 | peak |
| 6 | 17615.000 | 29.09 | 22.29 | 51.38 | 74.00 | -22.62 | peak |

- Note: 1. Measurement = Reading Level + Correct Factor.
 2. If Peak Result complies with AV limit, AV Result is deemed to comply with AV limit.
 3. Peak: Peak detector.
 4. AVG: $VBW=1/Ton$, where: Ton is the transmitting duration.
 5. For the transmitting duration, please refer to clause 7.1.
 6. Filter losses were only considered in the spurious frequency bands and the authorized band was not corrected for High Pass Filter losses.
 7. Proper operation of the transmitter prior to adding the filter to the measurement chain.
 8. Since non-restricted band peak emissions are less than the average limit, they also comply with the -27dBm/MHz (68.2dBuV/m) limit.

HARMONICS AND SPURIOUS EMISSIONS (HIGH CHANNEL, VERTICAL)

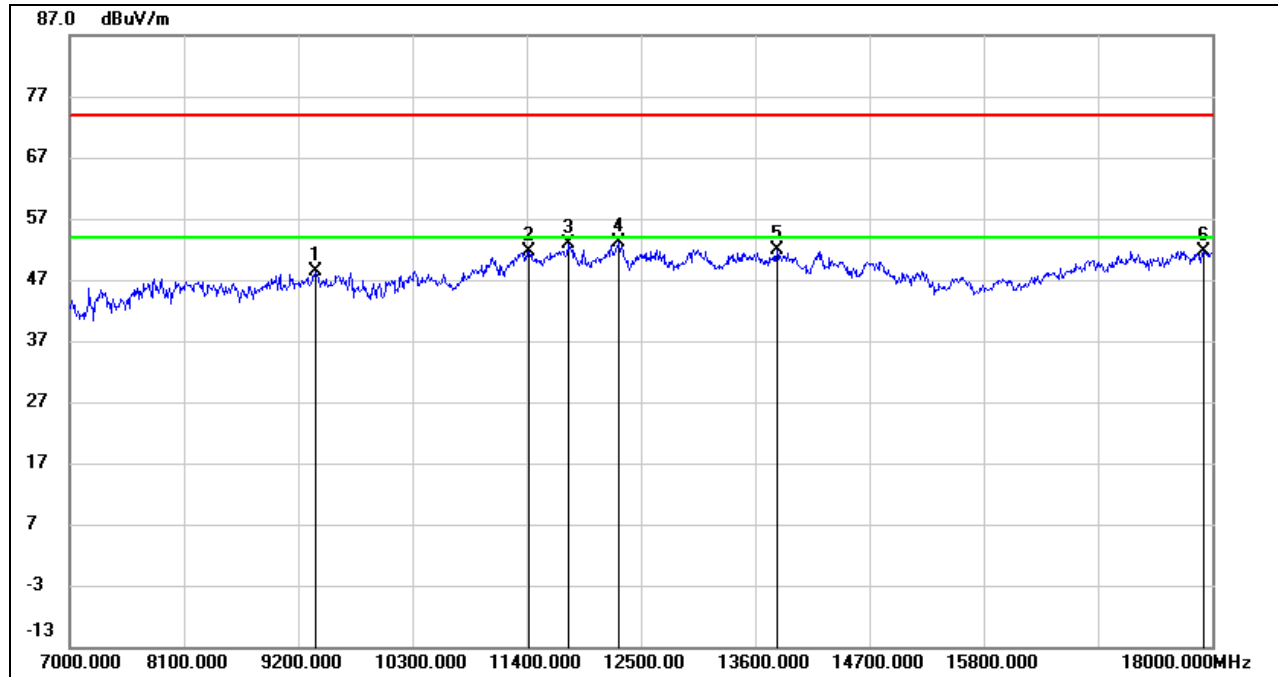

| No. | Frequency (MHz) | Reading (dBuV) | Correct (dB/m) | Result (dBuV/m) | Limit (dBuV/m) | Margin (dB) | Remark |
|-----|-----------------|----------------|----------------|-----------------|----------------|-------------|--------|
| 1 | 9365.000 | 37.35 | 11.08 | 48.43 | 74.00 | -25.57 | peak |
| 2 | 11422.000 | 34.59 | 17.13 | 51.72 | 74.00 | -22.28 | peak |
| 3 | 11796.000 | 34.36 | 18.43 | 52.79 | 74.00 | -21.21 | peak |
| 4 | 12291.000 | 35.03 | 17.98 | 53.01 | 74.00 | -20.99 | peak |
| 5 | 13809.000 | 31.85 | 19.93 | 51.78 | 74.00 | -22.22 | peak |
| 6 | 17923.000 | 27.25 | 24.48 | 51.73 | 74.00 | -22.27 | peak |

- Note:
1. Measurement = Reading Level + Correct Factor.
 2. If Peak Result complies with AV limit, AV Result is deemed to comply with AV limit.
 3. Peak: Peak detector.
 4. AVG: $VBW=1/Ton$, where: Ton is the transmitting duration.
 5. For the transmitting duration, please refer to clause 7.1.
 6. Filter losses were only considered in the spurious frequency bands and the authorized band was not corrected for High Pass Filter losses.
 7. Proper operation of the transmitter prior to adding the filter to the measurement chain.
 8. Since non-restricted band peak emissions are less than the average limit, they also comply with the -27dBm/MHz (68.2dBuV/m) limit.

STRADDLE CHANNEL 142

HARMONICS AND SPURIOUS EMISSIONS (HORIZONTAL)

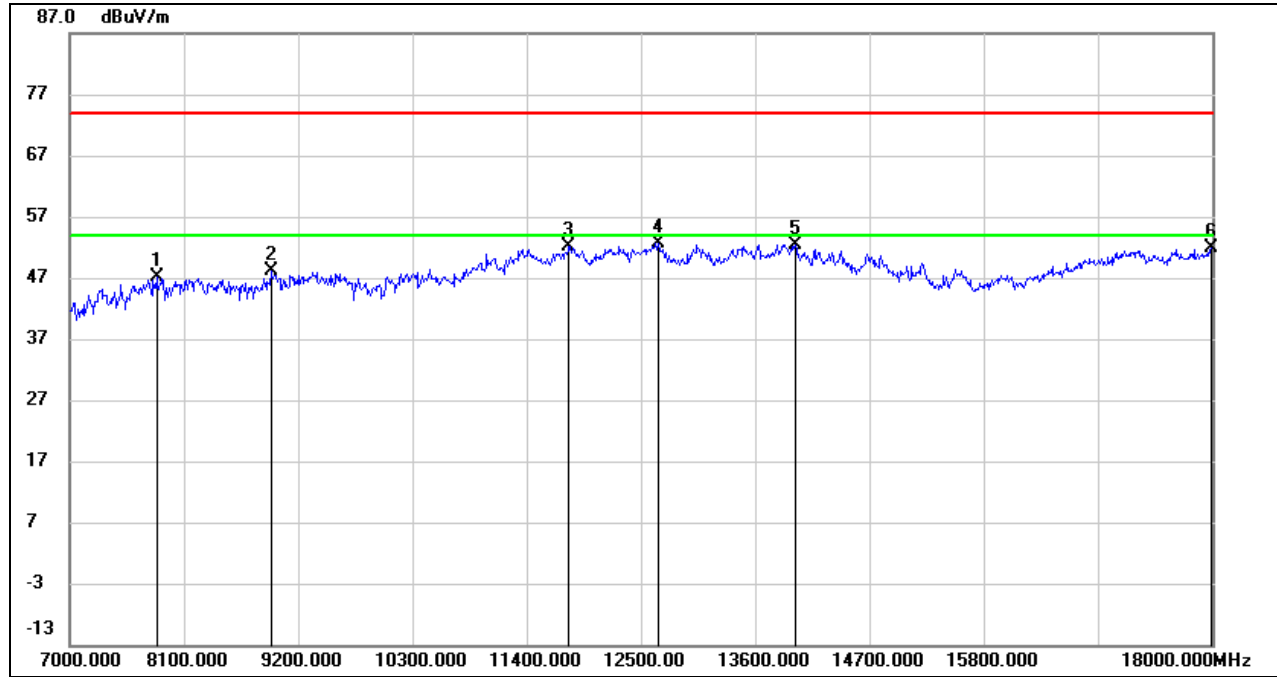

| No. | Frequency (MHz) | Reading (dBuV) | Correct (dB/m) | Result (dBuV/m) | Limit (dBuV/m) | Margin (dB) | Remark |
|-----|-----------------|----------------|----------------|-----------------|----------------|-------------|--------|
| 1 | 7836.000 | 38.33 | 8.75 | 47.08 | 74.00 | -26.92 | peak |
| 2 | 8936.000 | 37.66 | 10.57 | 48.23 | 74.00 | -25.77 | peak |
| 3 | 11807.000 | 33.66 | 18.44 | 52.10 | 74.00 | -21.90 | peak |
| 4 | 12665.000 | 34.48 | 18.19 | 52.67 | 74.00 | -21.33 | peak |
| 5 | 13985.000 | 32.86 | 19.61 | 52.47 | 74.00 | -21.53 | peak |
| 6 | 17989.000 | 27.20 | 24.68 | 51.88 | 74.00 | -22.12 | peak |

- Note:
1. Measurement = Reading Level + Correct Factor.
 2. If Peak Result complies with AV limit, AV Result is deemed to comply with AV limit.
 3. Peak: Peak detector.
 4. AVG: VBW=1/Ton, where: Ton is the transmitting duration.
 5. For the transmitting duration, please refer to clause 7.1.
 6. Filter losses were only considered in the spurious frequency bands and the authorized band was not corrected for High Pass Filter losses.
 7. Proper operation of the transmitter prior to adding the filter to the measurement chain.
 8. Since non-restricted band peak emissions are less than the average limit, they also comply with the -27dBm/MHz (68.2dBuV/m) limit.



HARMONICS AND SPURIOUS EMISSIONS (VERTICAL)

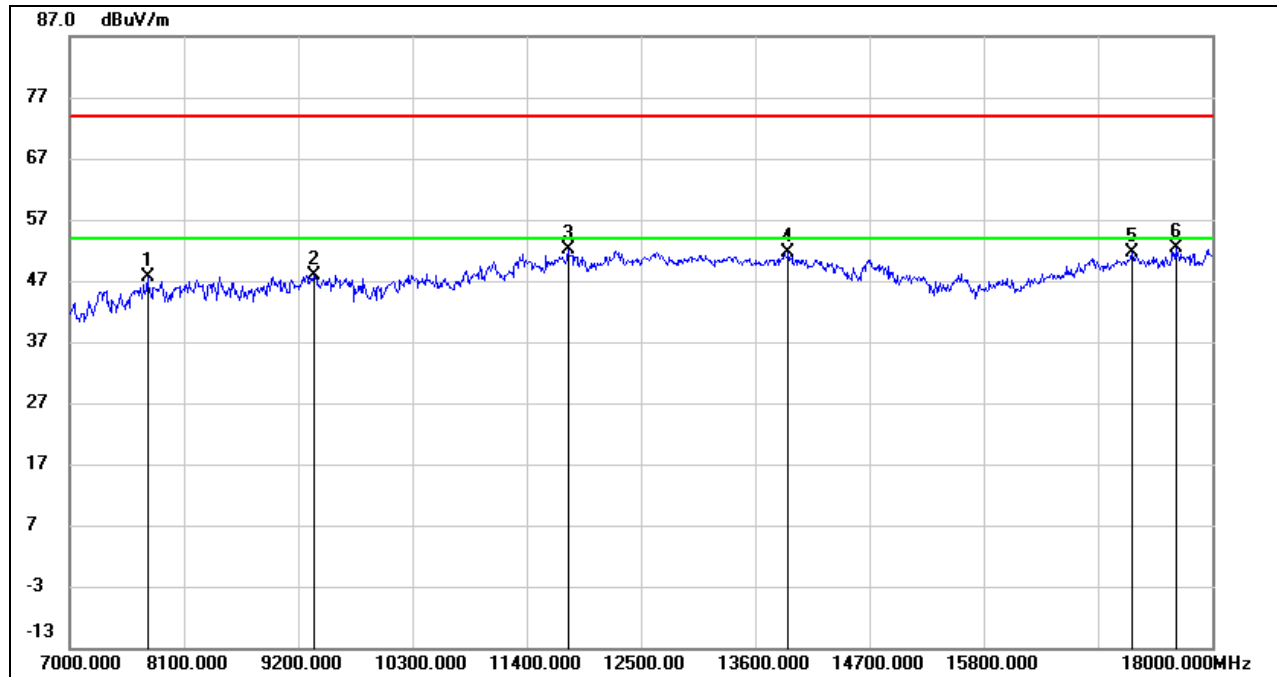

| No. | Frequency (MHz) | Reading (dBuV) | Correct (dB/m) | Result (dBuV/m) | Limit (dBuV/m) | Margin (dB) | Remark |
|-----|-----------------|----------------|----------------|-----------------|----------------|-------------|--------|
| 1 | 7748.000 | 39.01 | 8.64 | 47.65 | 74.00 | -26.35 | peak |
| 2 | 9354.000 | 36.97 | 11.02 | 47.99 | 74.00 | -26.01 | peak |
| 3 | 11796.000 | 33.73 | 18.43 | 52.16 | 74.00 | -21.84 | peak |
| 4 | 13919.000 | 31.94 | 19.72 | 51.66 | 74.00 | -22.34 | peak |
| 5 | 17230.000 | 30.50 | 21.13 | 51.63 | 74.00 | -22.37 | peak |
| 6 | 17648.000 | 29.82 | 22.61 | 52.43 | 74.00 | -21.57 | peak |

- Note:
1. Measurement = Reading Level + Correct Factor.
 2. If Peak Result complies with AV limit, AV Result is deemed to comply with AV limit.
 3. Peak: Peak detector.
 4. AVG: $VBW=1/Ton$, where: Ton is the transmitting duration.
 5. For the transmitting duration, please refer to clause 7.1.
 6. Filter losses were only considered in the spurious frequency bands and the authorized band was not corrected for High Pass Filter losses.
 7. Proper operation of the transmitter prior to adding the filter to the measurement chain.
 8. Since non-restricted band peak emissions are less than the average limit, they also comply with the -27dBm/MHz (68.2dBuV/m) limit.



UNII-3 BAND

HARMONICS AND SPURIOUS EMISSIONS (LOW CHANNEL, HORIZONTAL)

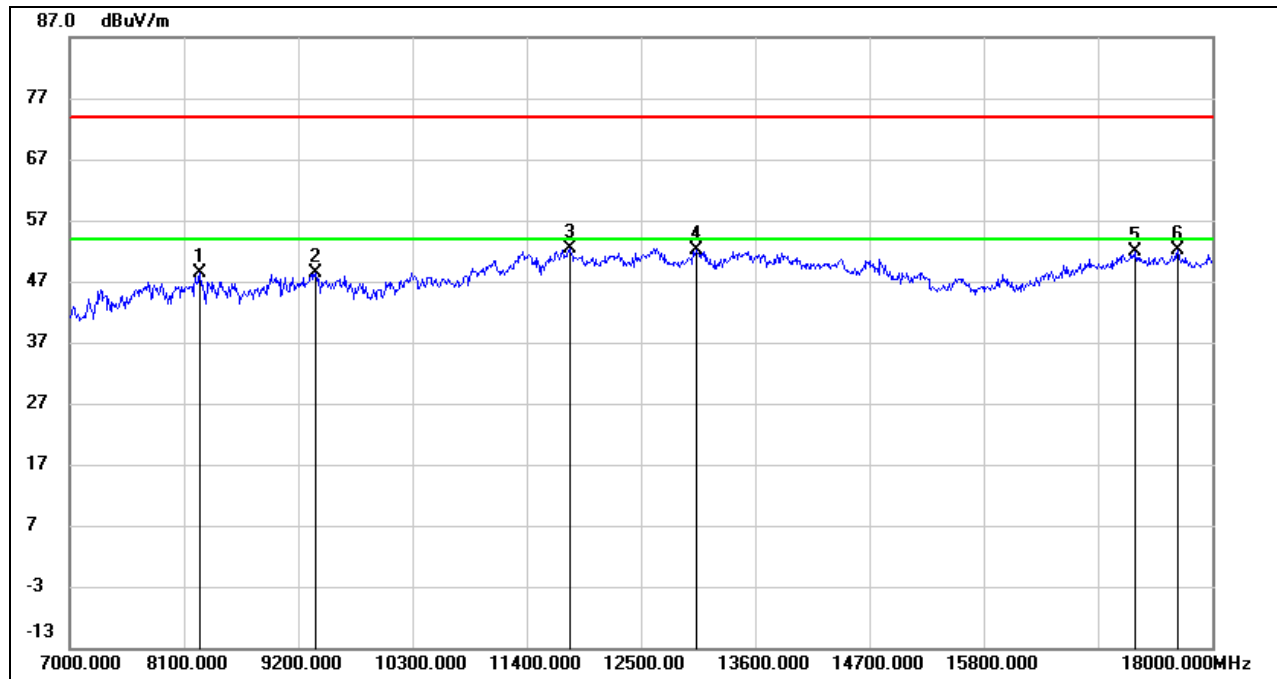

| No. | Frequency (MHz) | Reading (dBuV) | Correct (dB/m) | Result (dBuV/m) | Limit (dBuV/m) | Margin (dB) | Remark |
|-----|-----------------|----------------|----------------|-----------------|----------------|-------------|--------|
| 1 | 8254.000 | 38.63 | 9.69 | 48.32 | 74.00 | -25.68 | peak |
| 2 | 9365.000 | 37.40 | 11.08 | 48.48 | 74.00 | -25.52 | peak |
| 3 | 11818.000 | 34.08 | 18.41 | 52.49 | 74.00 | -21.51 | peak |
| 4 | 13028.000 | 33.86 | 18.38 | 52.24 | 74.00 | -21.76 | peak |
| 5 | 17263.000 | 30.73 | 21.11 | 51.84 | 74.00 | -22.16 | peak |
| 6 | 17670.000 | 29.20 | 22.82 | 52.02 | 74.00 | -21.98 | peak |

- Note: 1. Measurement = Reading Level + Correct Factor.
 2. If Peak Result complies with AV limit, AV Result is deemed to comply with AV limit.
 3. Peak: Peak detector.
 4. AVG: VBW=1/Ton, where: Ton is the transmitting duration.
 5. For the transmitting duration, please refer to clause 7.1.
 6. Filter losses were only considered in the spurious frequency bands and the authorized band was not corrected for High Pass Filter losses.
 7. Proper operation of the transmitter prior to adding the filter to the measurement chain.
 8. Since non-restricted band peak emissions are less than the average limit, they also comply with the -27dBm/MHz (68.2dBuV/m) limit.

HARMONICS AND SPURIOUS EMISSIONS (LOW CHANNEL, VERTICAL)

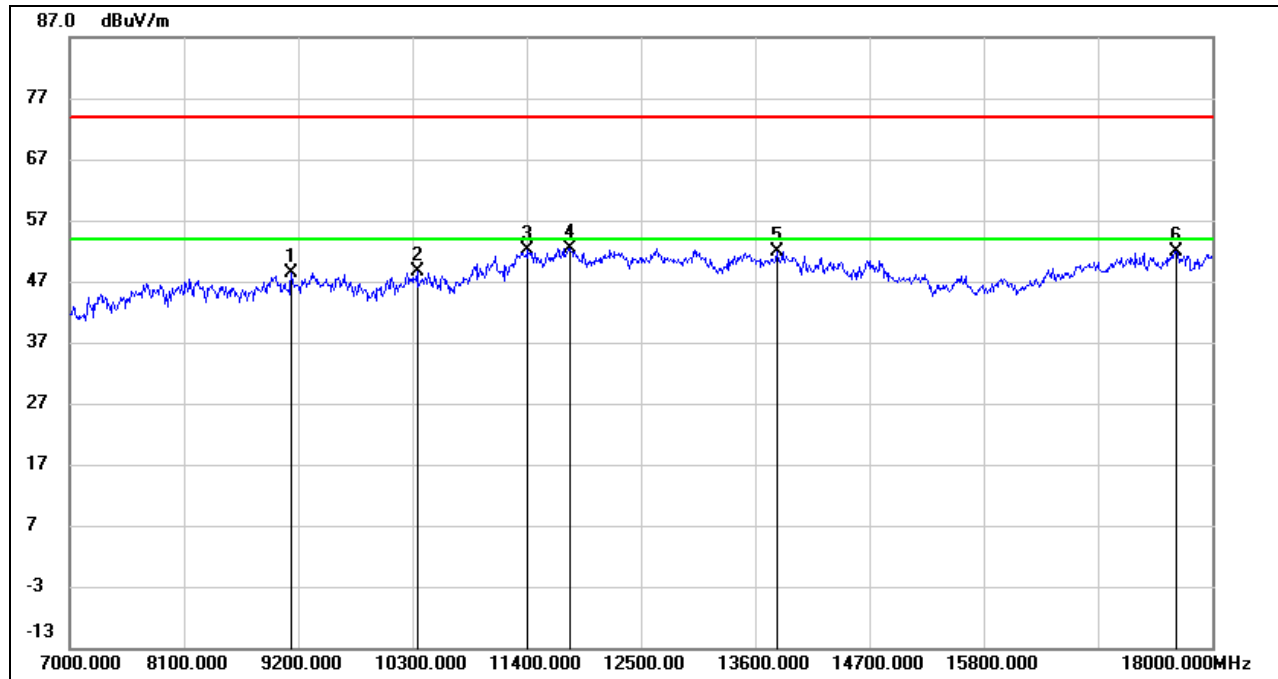

| No. | Frequency (MHz) | Reading (dBuV) | Correct (dB/m) | Result (dBuV/m) | Limit (dBuV/m) | Margin (dB) | Remark |
|-----|-----------------|----------------|----------------|-----------------|----------------|-------------|--------|
| 1 | 9134.000 | 37.73 | 10.55 | 48.28 | 74.00 | -25.72 | peak |
| 2 | 10344.000 | 35.62 | 12.91 | 48.53 | 74.00 | -25.47 | peak |
| 3 | 11411.000 | 35.11 | 17.08 | 52.19 | 74.00 | -21.81 | peak |
| 4 | 11818.000 | 34.06 | 18.41 | 52.47 | 74.00 | -21.53 | peak |
| 5 | 13809.000 | 32.06 | 19.93 | 51.99 | 74.00 | -22.01 | peak |
| 6 | 17648.000 | 29.36 | 22.61 | 51.97 | 74.00 | -22.03 | peak |

- Note: 1. Measurement = Reading Level + Correct Factor.
 2. If Peak Result complies with AV limit, AV Result is deemed to comply with AV limit.
 3. Peak: Peak detector.
 4. AVG: $VBW=1/Ton$, where: Ton is the transmitting duration.
 5. For the transmitting duration, please refer to clause 7.1.
 6. Filter losses were only considered in the spurious frequency bands and the authorized band was not corrected for High Pass Filter losses.
 7. Proper operation of the transmitter prior to adding the filter to the measurement chain.
 8. Since non-restricted band peak emissions are less than the average limit, they also comply with the -27dBm/MHz (68.2dBuV/m) limit.



HARMONICS AND SPURIOUS EMISSIONS (HIGH CHANNEL, HORIZONTAL)

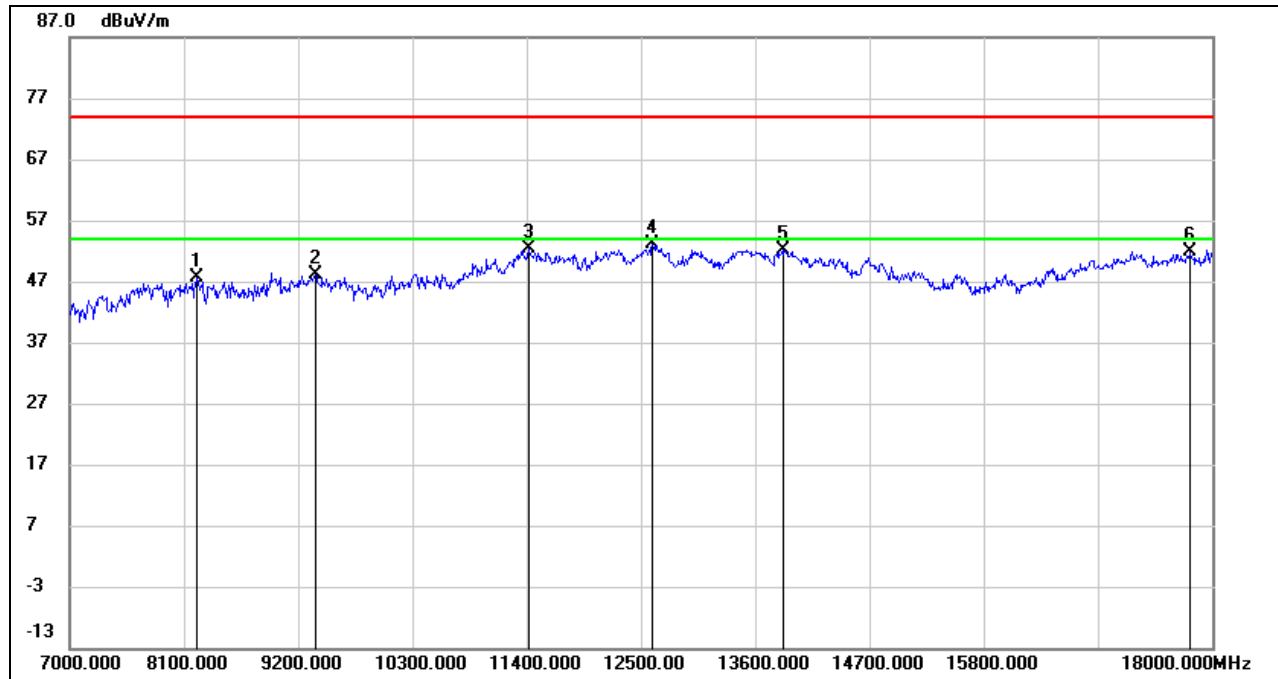

| No. | Frequency (MHz) | Reading (dBuV) | Correct (dB/m) | Result (dBuV/m) | Limit (dBuV/m) | Margin (dB) | Remark |
|-----|-----------------|----------------|----------------|-----------------|----------------|-------------|--------|
| 1 | 8221.000 | 37.83 | 9.81 | 47.64 | 74.00 | -26.36 | peak |
| 2 | 9365.000 | 37.08 | 11.08 | 48.16 | 74.00 | -25.84 | peak |
| 3 | 11422.000 | 35.20 | 17.13 | 52.33 | 74.00 | -21.67 | peak |
| 4 | 12610.000 | 34.88 | 18.16 | 53.04 | 74.00 | -20.96 | peak |
| 5 | 13864.000 | 32.21 | 19.81 | 52.02 | 74.00 | -21.98 | peak |
| 6 | 17791.000 | 27.85 | 24.00 | 51.85 | 74.00 | -22.15 | peak |

- Note: 1. Measurement = Reading Level + Correct Factor.
 2. If Peak Result complies with AV limit, AV Result is deemed to comply with AV limit.
 3. Peak: Peak detector.
 4. Filter losses were only considered in the spurious frequency bands and the authorized band was not corrected for High Pass Filter losses.
 5. Proper operation of the transmitter prior to adding the filter to the measurement chain.
 6. Since non-restricted band peak emissions are less than the average limit, they also comply with the -27dBm/MHz (68.2dBuV/m) limit.



HARMONICS AND SPURIOUS EMISSIONS (HIGH CHANNEL, VERTICAL)

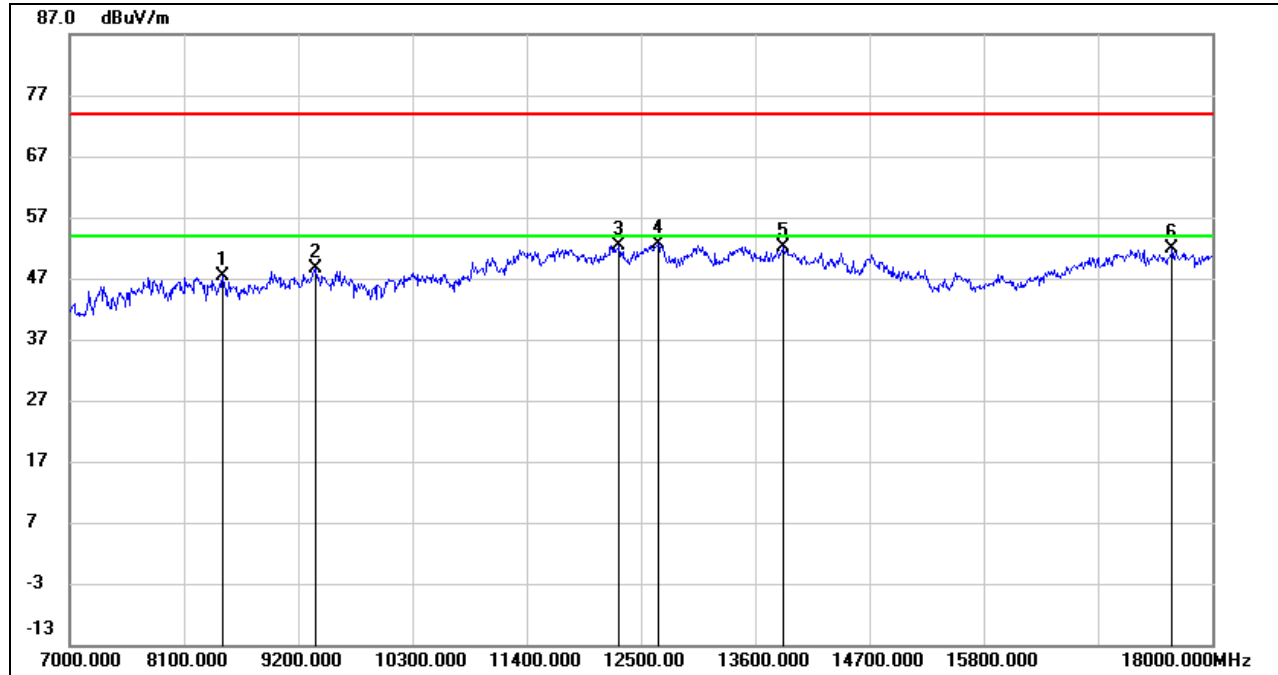

| No. | Frequency (MHz) | Reading (dBuV) | Correct (dB/m) | Result (dBuV/m) | Limit (dBuV/m) | Margin (dB) | Remark |
|-----|-----------------|----------------|----------------|-----------------|----------------|-------------|--------|
| 1 | 8474.000 | 38.23 | 9.04 | 47.27 | 74.00 | -26.73 | peak |
| 2 | 9365.000 | 37.60 | 11.08 | 48.68 | 74.00 | -25.32 | peak |
| 3 | 12291.000 | 34.49 | 17.98 | 52.47 | 74.00 | -21.53 | peak |
| 4 | 12665.000 | 34.34 | 18.19 | 52.53 | 74.00 | -21.47 | peak |
| 5 | 13864.000 | 32.31 | 19.81 | 52.12 | 74.00 | -21.88 | peak |
| 6 | 17615.000 | 29.54 | 22.29 | 51.83 | 74.00 | -22.17 | peak |

- Note: 1. Measurement = Reading Level + Correct Factor.
 2. If Peak Result complies with AV limit, AV Result is deemed to comply with AV limit.
 3. Peak: Peak detector.
 4. AVG: $VBW=1/Ton$, where: Ton is the transmitting duration.
 5. For the transmitting duration, please refer to clause 7.1.
 6. Filter losses were only considered in the spurious frequency bands and the authorized band was not corrected for High Pass Filter losses.
 7. Proper operation of the transmitter prior to adding the filter to the measurement chain.
 8. Since non-restricted band peak emissions are less than the average limit, they also comply with the -27dBm/MHz (68.2dBuV/m) limit.

8.3.4. 802.11ac VHT80 MIMO MODE

UNII-1 BAND

HARMONICS AND SPURIOUS EMISSIONS (LOW CHANNEL, HORIZONTAL)

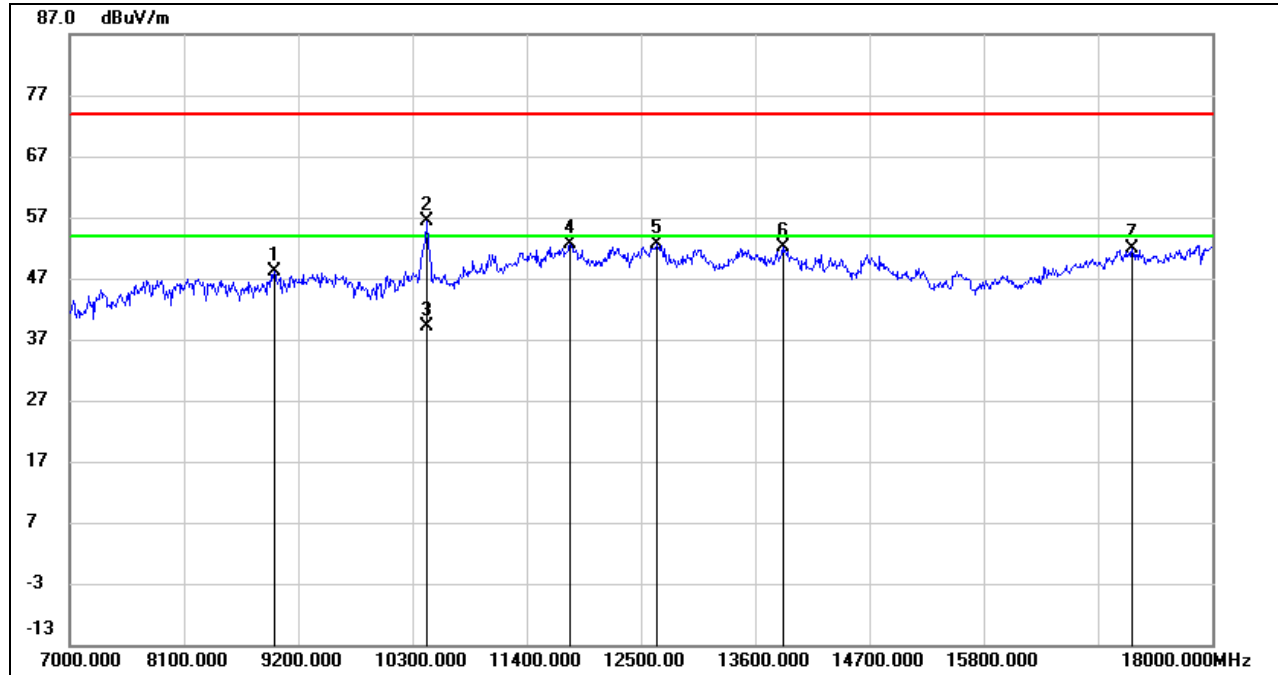

| No. | Frequency (MHz) | Reading (dBuV) | Correct (dB/m) | Result (dBuV/m) | Limit (dBuV/m) | Margin (dB) | Remark |
|-----|-----------------|----------------|----------------|-----------------|----------------|-------------|--------|
| 1 | 8969.000 | 37.19 | 10.90 | 48.09 | 74.00 | -25.91 | peak |
| 2 | 10443.000 | 43.01 | 13.34 | 56.35 | 74.00 | -17.65 | peak |
| 3 | 10443.000 | 25.82 | 13.34 | 39.16 | 54.00 | -14.84 | AVG |
| 4 | 11818.000 | 34.24 | 18.41 | 52.65 | 74.00 | -21.35 | peak |
| 5 | 12654.000 | 34.34 | 18.17 | 52.51 | 74.00 | -21.49 | peak |
| 6 | 13864.000 | 32.31 | 19.81 | 52.12 | 74.00 | -21.88 | peak |
| 7 | 17230.000 | 30.63 | 21.13 | 51.76 | 74.00 | -22.24 | peak |

- Note: 1. Measurement = Reading Level + Correct Factor.
 2. If Peak Result complies with AV limit, AV Result is deemed to comply with AV limit.
 3. Peak: Peak detector.
 4. AVG: $VBW=1/T_{on}$, where: T_{on} is the transmitting duration.
 5. For the transmitting duration, please refer to clause 7.1.
 6. Filter losses were only considered in the spurious frequency bands and the authorized band was not corrected for High Pass Filter losses.
 7. Proper operation of the transmitter prior to adding the filter to the measurement chain.
 8. Since non-restricted band peak emissions are less than the average limit, they also comply with the -27dBm/MHz (68.2dBuV/m) limit.

HARMONICS AND SPURIOUS EMISSIONS (LOW CHANNEL, VERTICAL)

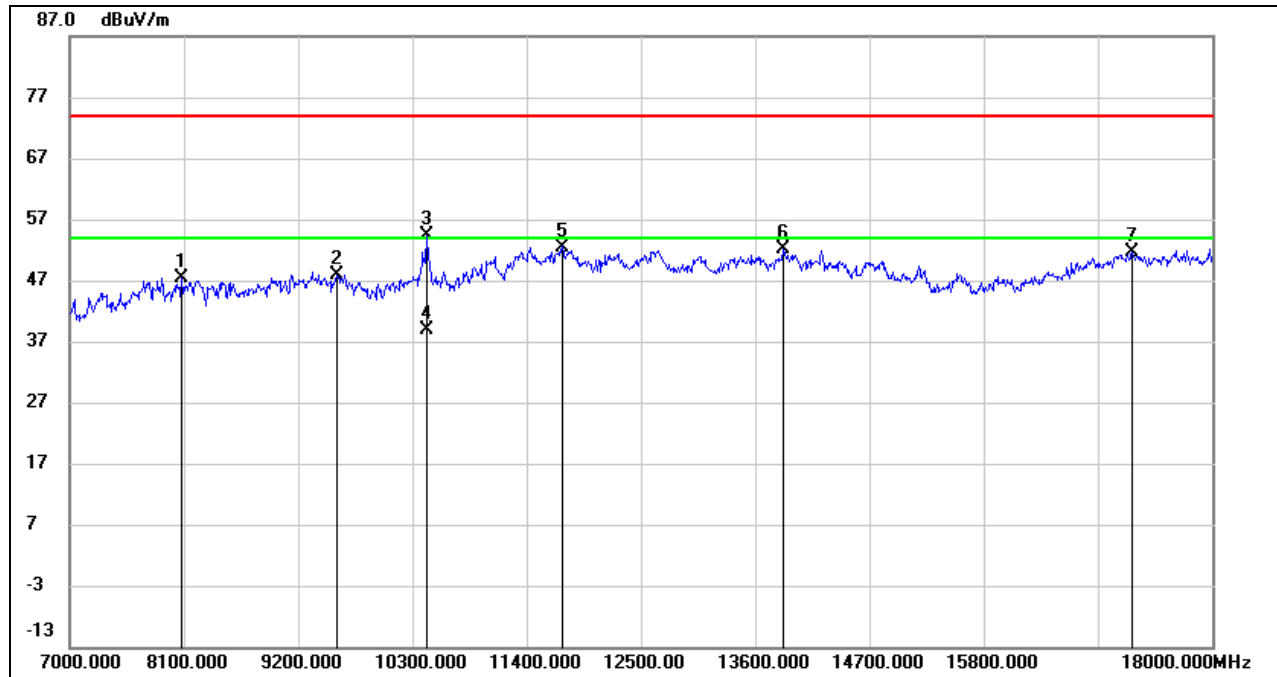

| No. | Frequency (MHz) | Reading (dBuV) | Correct (dB/m) | Result (dBuV/m) | Limit (dBuV/m) | Margin (dB) | Remark |
|-----|-----------------|----------------|----------------|-----------------|----------------|-------------|--------|
| 1 | 8078.000 | 38.49 | 8.96 | 47.45 | 74.00 | -26.55 | peak |
| 2 | 9574.000 | 36.00 | 11.90 | 47.90 | 74.00 | -26.10 | peak |
| 3 | 10432.000 | 40.99 | 13.28 | 54.27 | 74.00 | -19.73 | peak |
| 4 | 10432.000 | 25.48 | 13.28 | 38.76 | 54.00 | -15.24 | AVG |
| 5 | 11741.000 | 34.32 | 18.18 | 52.50 | 74.00 | -21.50 | peak |
| 6 | 13875.000 | 32.23 | 19.81 | 52.04 | 74.00 | -21.96 | peak |
| 7 | 17230.000 | 30.43 | 21.13 | 51.56 | 74.00 | -22.44 | peak |

Note: 1. Measurement = Reading Level + Correct Factor.
 2. If Peak Result complies with AV limit, AV Result is deemed to comply with AV limit.
 3. Peak: Peak detector.
 4. AVG: VBW=1/Ton, where: Ton is the transmitting duration.
 5. For the transmitting duration, please refer to clause 7.1.
 6. Filter losses were only considered in the spurious frequency bands and the authorized band was not corrected for High Pass Filter losses.
 7. Proper operation of the transmitter prior to adding the filter to the measurement chain.
 8. Since non-restricted band peak emissions are less than the average limit, they also comply with the -27dBm/MHz (68.2dBuV/m) limit.

UNII-2A BAND

HARMONICS AND SPURIOUS EMISSIONS (LOW CHANNEL, HORIZONTAL)

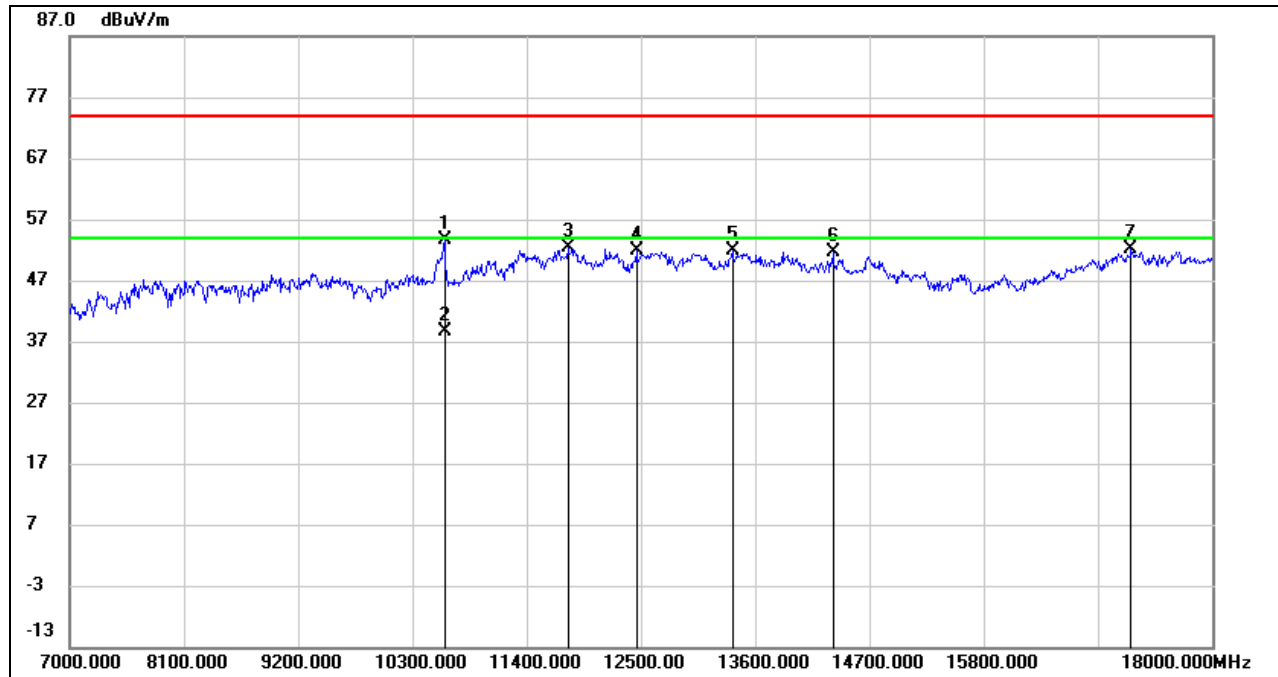

| No. | Frequency (MHz) | Reading (dBuV) | Correct (dB/m) | Result (dBuV/m) | Limit (dBuV/m) | Margin (dB) | Remark |
|-----|-----------------|----------------|----------------|-----------------|----------------|-------------|--------|
| 1 | 10608.000 | 39.56 | 14.06 | 53.62 | 74.00 | -20.38 | peak |
| 2 | 10608.000 | 24.59 | 14.06 | 38.65 | 54.00 | -15.35 | AVG |
| 3 | 11796.000 | 33.95 | 18.43 | 52.38 | 74.00 | -21.62 | peak |
| 4 | 12456.000 | 33.74 | 18.05 | 51.79 | 74.00 | -22.21 | peak |
| 5 | 13380.000 | 32.68 | 19.23 | 51.91 | 74.00 | -22.09 | peak |
| 6 | 14348.000 | 33.03 | 18.66 | 51.69 | 74.00 | -22.31 | peak |
| 7 | 17219.000 | 31.02 | 21.14 | 52.16 | 74.00 | -21.84 | peak |

Note: 1. Measurement = Reading Level + Correct Factor.
 2. If Peak Result complies with AV limit, AV Result is deemed to comply with AV limit.
 3. Peak: Peak detector.
 4. Filter losses were only considered in the spurious frequency bands and the authorized band was not corrected for High Pass Filter losses.
 5. Proper operation of the transmitter prior to adding the filter to the measurement chain.
 6. Since non-restricted band peak emissions are less than the average limit, they also comply with the -27dBm/MHz (68.2dBuV/m) limit.



HARMONICS AND SPURIOUS EMISSIONS (LOW CHANNEL, VERTICAL)

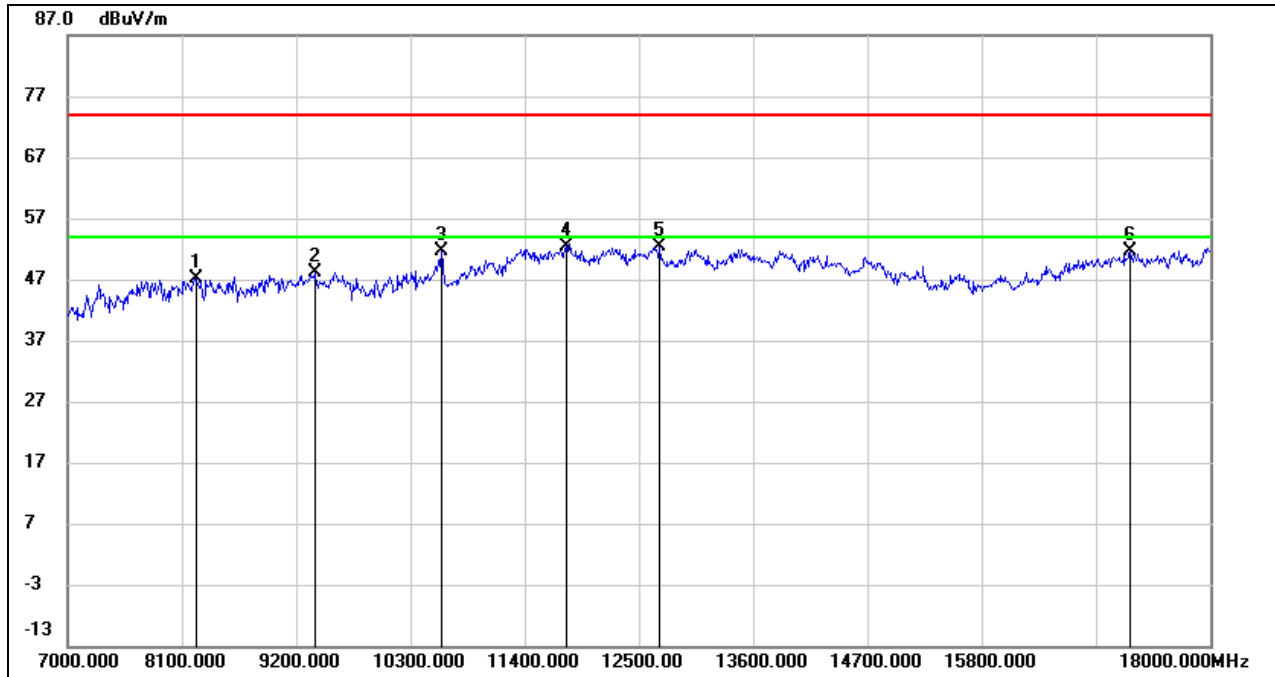

| No. | Frequency (MHz) | Reading (dBuV) | Correct (dB/m) | Result (dBuV/m) | Limit (dBuV/m) | Margin (dB) | Remark |
|-----|-----------------|----------------|----------------|-----------------|----------------|-------------|--------|
| 1 | 8232.000 | 37.46 | 9.77 | 47.23 | 74.00 | -26.77 | peak |
| 2 | 9376.000 | 37.03 | 11.14 | 48.17 | 74.00 | -25.83 | peak |
| 3 | 10597.000 | 37.53 | 14.03 | 51.56 | 74.00 | -22.44 | peak |
| 4 | 11807.000 | 34.02 | 18.44 | 52.46 | 74.00 | -21.54 | peak |
| 5 | 12698.000 | 34.15 | 18.19 | 52.34 | 74.00 | -21.66 | peak |
| 6 | 17230.000 | 30.48 | 21.13 | 51.61 | 74.00 | -22.39 | peak |

- Note: 1. Measurement = Reading Level + Correct Factor.
 2. If Peak Result complies with AV limit, AV Result is deemed to comply with AV limit.
 3. Peak: Peak detector.
 4. AVG: $VBW=1/Ton$, where: Ton is the transmitting duration.
 5. For the transmitting duration, please refer to clause 7.1.
 6. Filter losses were only considered in the spurious frequency bands and the authorized band was not corrected for High Pass Filter losses.
 7. Proper operation of the transmitter prior to adding the filter to the measurement chain.
 8. Since non-restricted band peak emissions are less than the average limit, they also comply with the -27dBm/MHz (68.2dBuV/m) limit.



UNII-2C BAND

HARMONICS AND SPURIOUS EMISSIONS (LOW CHANNEL, HORIZONTAL)

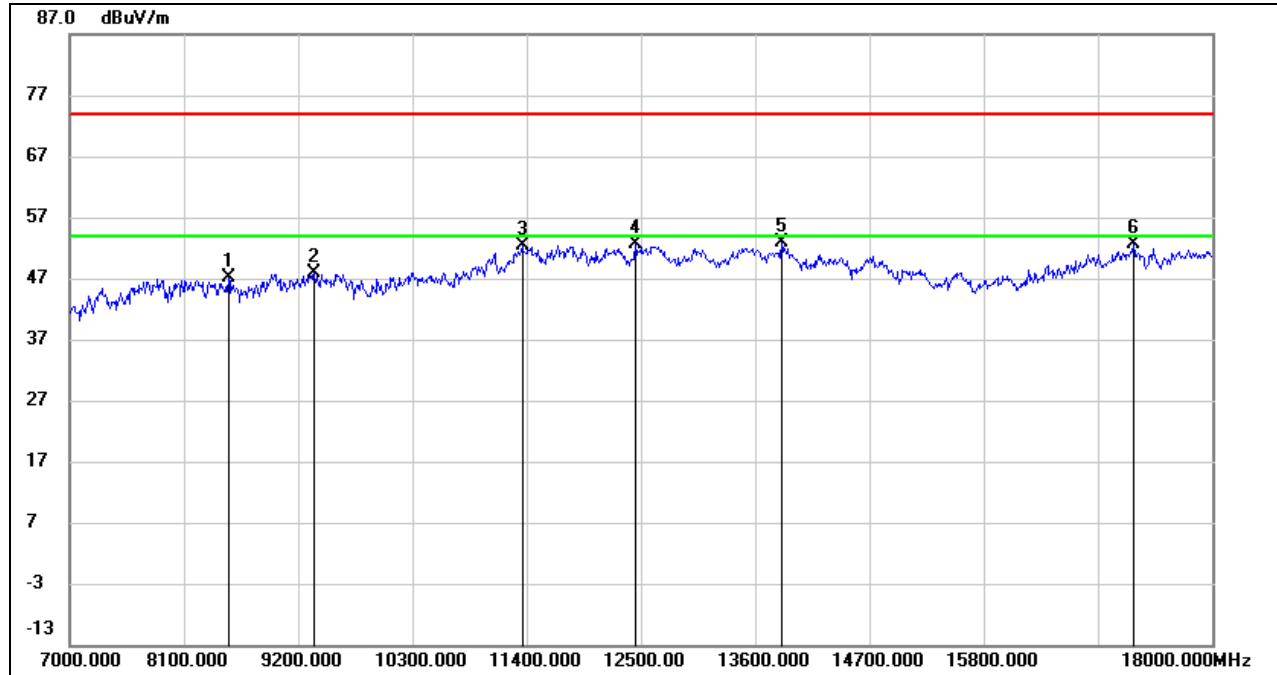

| No. | Frequency (MHz) | Reading (dBuV) | Correct (dB/m) | Result (dBuV/m) | Limit (dBuV/m) | Margin (dB) | Remark |
|-----|-----------------|----------------|----------------|-----------------|----------------|-------------|--------|
| 1 | 8529.000 | 38.21 | 9.01 | 47.22 | 74.00 | -26.78 | peak |
| 2 | 9354.000 | 36.96 | 11.02 | 47.98 | 74.00 | -26.02 | peak |
| 3 | 11356.000 | 35.54 | 16.86 | 52.40 | 74.00 | -21.60 | peak |
| 4 | 12445.000 | 34.67 | 18.04 | 52.71 | 74.00 | -21.29 | peak |
| 5 | 13853.000 | 32.93 | 19.84 | 52.77 | 74.00 | -21.23 | peak |
| 6 | 17241.000 | 31.52 | 21.12 | 52.64 | 74.00 | -21.36 | peak |

- Note:
1. Measurement = Reading Level + Correct Factor.
 2. If Peak Result complies with AV limit, AV Result is deemed to comply with AV limit.
 3. Peak: Peak detector.
 4. AVG: $VBW=1/Ton$, where: Ton is the transmitting duration.
 5. For the transmitting duration, please refer to clause 7.1.
 6. Filter losses were only considered in the spurious frequency bands and the authorized band was not corrected for High Pass Filter losses.
 7. Proper operation of the transmitter prior to adding the filter to the measurement chain.
 8. Since non-restricted band peak emissions are less than the average limit, they also comply with the -27dBm/MHz (68.2dBuV/m) limit.



HARMONICS AND SPURIOUS EMISSIONS (LOW CHANNEL, VERTICAL)

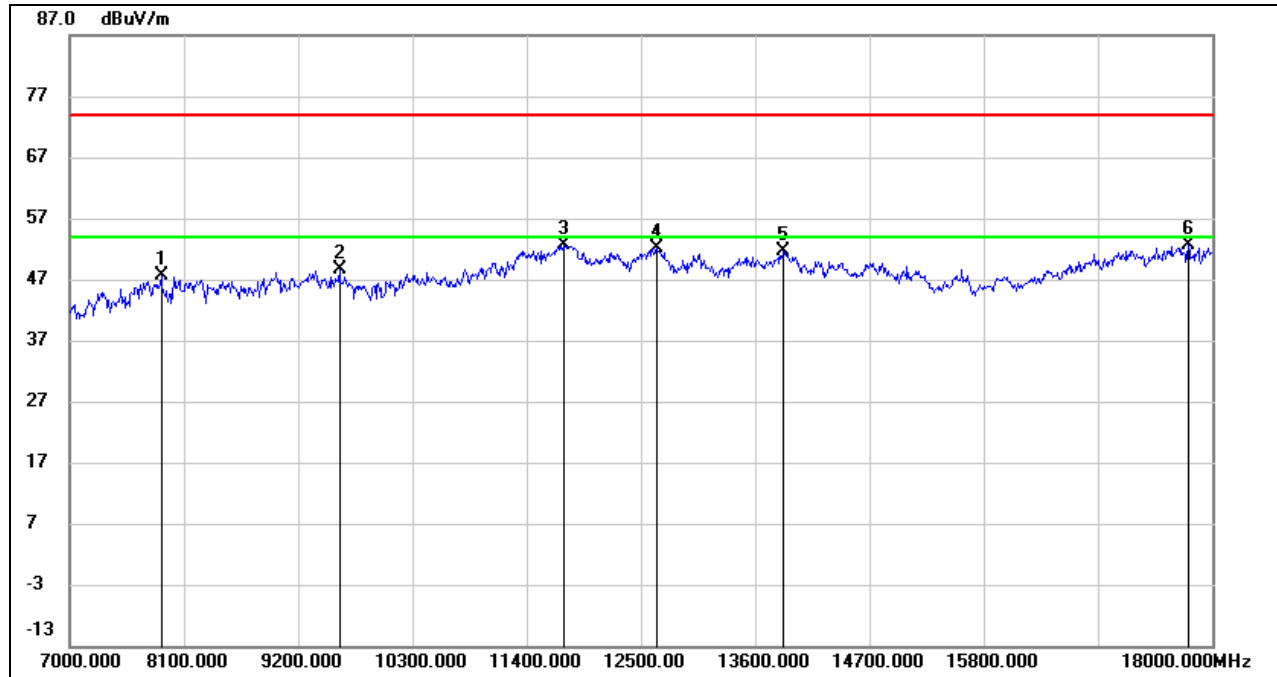

| No. | Frequency (MHz) | Reading (dBuV) | Correct (dB/m) | Result (dBuV/m) | Limit (dBuV/m) | Margin (dB) | Remark |
|-----|-----------------|----------------|----------------|-----------------|----------------|-------------|--------|
| 1 | 7880.000 | 38.93 | 8.64 | 47.57 | 74.00 | -26.43 | peak |
| 2 | 9596.000 | 36.75 | 11.98 | 48.73 | 74.00 | -25.27 | peak |
| 3 | 11752.000 | 34.35 | 18.23 | 52.58 | 74.00 | -21.42 | peak |
| 4 | 12654.000 | 34.07 | 18.17 | 52.24 | 74.00 | -21.76 | peak |
| 5 | 13875.000 | 31.87 | 19.81 | 51.68 | 74.00 | -22.32 | peak |
| 6 | 17769.000 | 28.77 | 23.78 | 52.55 | 74.00 | -21.45 | peak |

- Note:
1. Measurement = Reading Level + Correct Factor.
 2. If Peak Result complies with AV limit, AV Result is deemed to comply with AV limit.
 3. Peak: Peak detector.
 4. AVG: $VBW=1/Ton$, where: Ton is the transmitting duration.
 5. For the transmitting duration, please refer to clause 7.1.
 6. Filter losses were only considered in the spurious frequency bands and the authorized band was not corrected for High Pass Filter losses.
 7. Proper operation of the transmitter prior to adding the filter to the measurement chain.
 8. Since non-restricted band peak emissions are less than the average limit, they also comply with the -27dBm/MHz (68.2dBuV/m) limit.



HARMONICS AND SPURIOUS EMISSIONS (HIGH CHANNEL, HORIZONTAL)

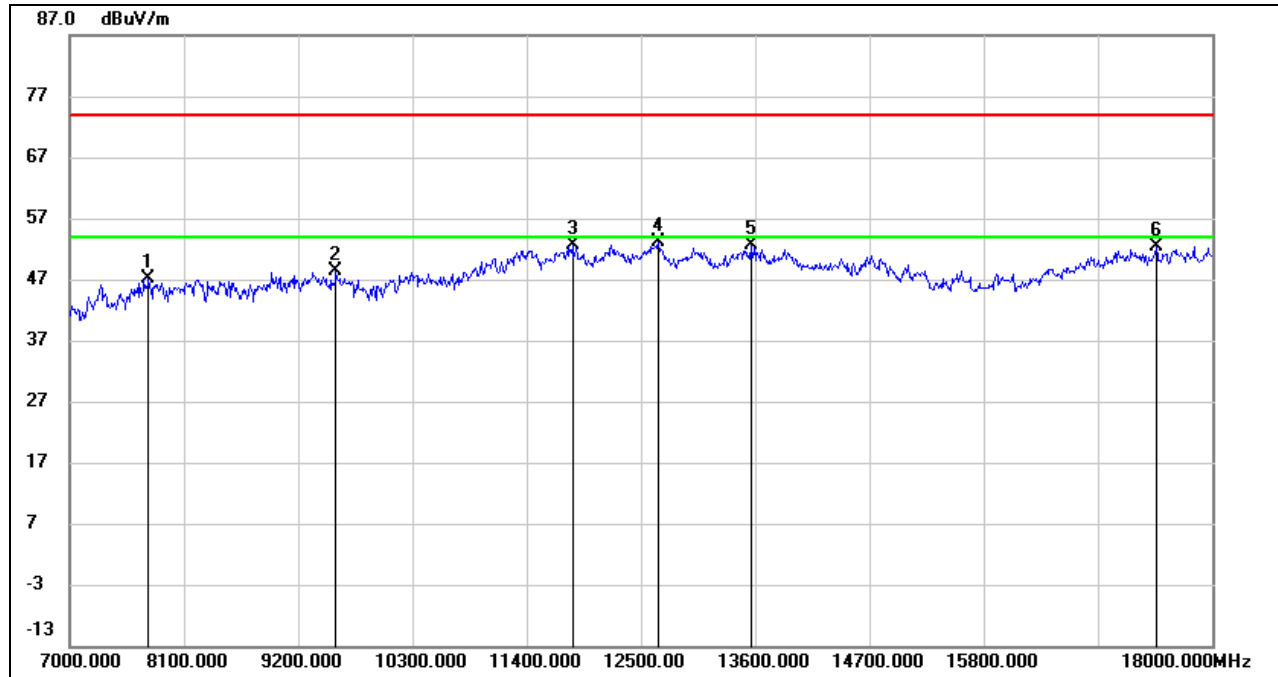

| No. | Frequency (MHz) | Reading (dBuV) | Correct (dB/m) | Result (dBuV/m) | Limit (dBuV/m) | Margin (dB) | Remark |
|-----|-----------------|----------------|----------------|-----------------|----------------|-------------|--------|
| 1 | 7759.000 | 38.44 | 8.69 | 47.13 | 74.00 | -26.87 | peak |
| 2 | 9563.000 | 36.64 | 11.86 | 48.50 | 74.00 | -25.50 | peak |
| 3 | 11840.000 | 34.28 | 18.39 | 52.67 | 74.00 | -21.33 | peak |
| 4 | 12665.000 | 34.83 | 18.19 | 53.02 | 74.00 | -20.98 | peak |
| 5 | 13556.000 | 33.33 | 19.41 | 52.74 | 74.00 | -21.26 | peak |
| 6 | 17461.000 | 31.21 | 21.21 | 52.42 | 74.00 | -21.58 | peak |

- Note: 1. Measurement = Reading Level + Correct Factor.
 2. If Peak Result complies with AV limit, AV Result is deemed to comply with AV limit.
 3. Peak: Peak detector.
 4. AVG: $VBW=1/Ton$, where: Ton is the transmitting duration.
 5. For the transmitting duration, please refer to clause 7.1.
 6. Filter losses were only considered in the spurious frequency bands and the authorized band was not corrected for High Pass Filter losses.
 7. Proper operation of the transmitter prior to adding the filter to the measurement chain.
 8. Since non-restricted band peak emissions are less than the average limit, they also comply with the -27dBm/MHz (68.2dBuV/m) limit.

HARMONICS AND SPURIOUS EMISSIONS (HIGH CHANNEL, VERTICAL)

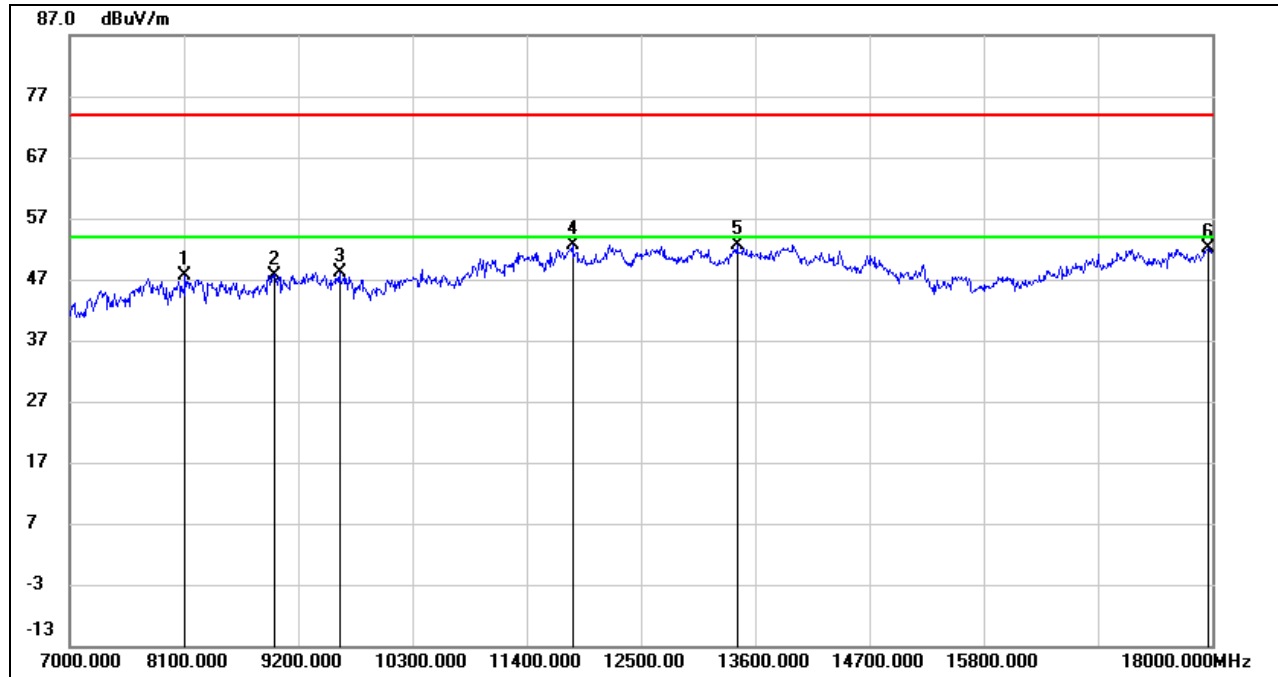

| No. | Frequency (MHz) | Reading (dBuV) | Correct (dB/m) | Result (dBuV/m) | Limit (dBuV/m) | Margin (dB) | Remark |
|-----|-----------------|----------------|----------------|-----------------|----------------|-------------|--------|
| 1 | 8111.000 | 38.30 | 9.21 | 47.51 | 74.00 | -26.49 | peak |
| 2 | 8969.000 | 36.85 | 10.90 | 47.75 | 74.00 | -26.25 | peak |
| 3 | 9596.000 | 36.25 | 11.98 | 48.23 | 74.00 | -25.77 | peak |
| 4 | 11840.000 | 34.13 | 18.39 | 52.52 | 74.00 | -21.48 | peak |
| 5 | 13424.000 | 33.38 | 19.35 | 52.73 | 74.00 | -21.27 | peak |
| 6 | 17967.000 | 27.47 | 24.61 | 52.08 | 74.00 | -21.92 | peak |

- Note:
1. Measurement = Reading Level + Correct Factor.
 2. If Peak Result complies with AV limit, AV Result is deemed to comply with AV limit.
 3. Peak: Peak detector.
 4. AVG: $VBW=1/Ton$, where: Ton is the transmitting duration.
 5. For the transmitting duration, please refer to clause 7.1.
 6. Filter losses were only considered in the spurious frequency bands and the authorized band was not corrected for High Pass Filter losses.
 7. Proper operation of the transmitter prior to adding the filter to the measurement chain.
 8. Since non-restricted band peak emissions are less than the average limit, they also comply with the -27dBm/MHz (68.2dBuV/m) limit.



STRADDLE CHANNEL 138

HARMONICS AND SPURIOUS EMISSIONS (HIGH CHANNEL, HORIZONTAL)

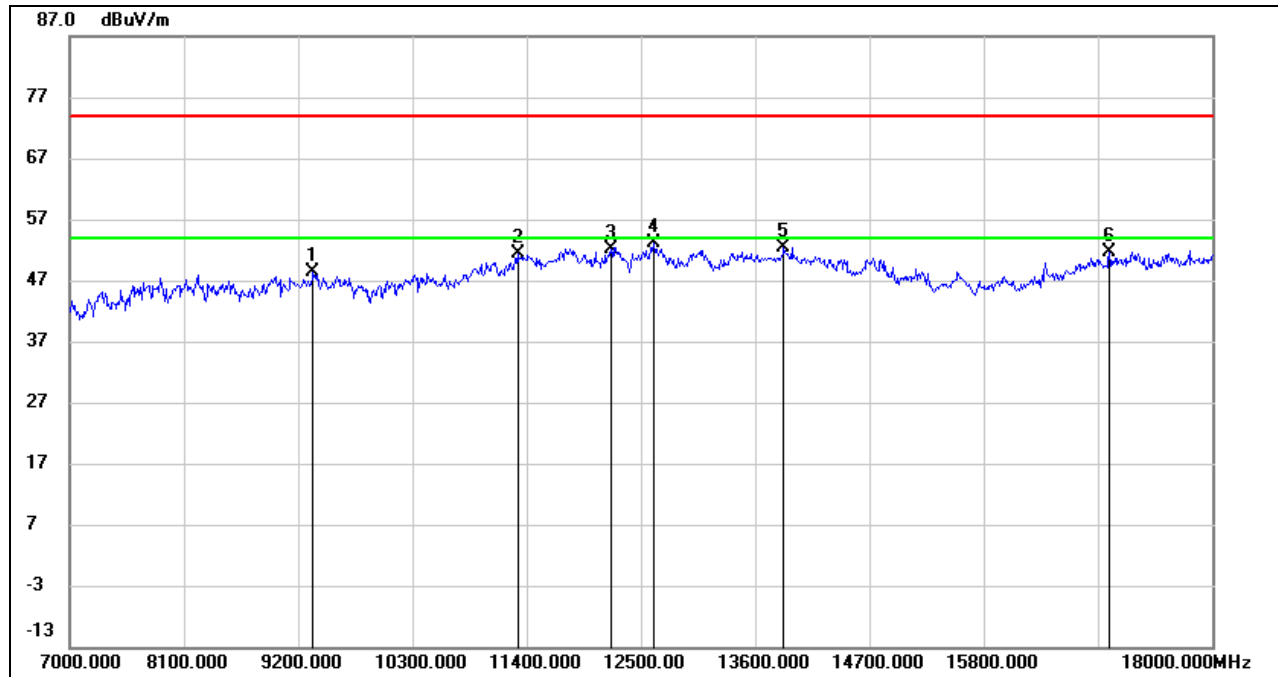

| No. | Frequency (MHz) | Reading (dBuV) | Correct (dB/m) | Result (dBuV/m) | Limit (dBuV/m) | Margin (dB) | Remark |
|-----|-----------------|----------------|----------------|-----------------|----------------|-------------|--------|
| 1 | 9343.000 | 37.40 | 10.97 | 48.37 | 74.00 | -25.63 | peak |
| 2 | 11312.000 | 34.67 | 16.66 | 51.33 | 74.00 | -22.67 | peak |
| 3 | 12214.000 | 34.23 | 17.93 | 52.16 | 74.00 | -21.84 | peak |
| 4 | 12621.000 | 34.97 | 18.18 | 53.15 | 74.00 | -20.85 | peak |
| 5 | 13875.000 | 32.57 | 19.81 | 52.38 | 74.00 | -21.62 | peak |
| 6 | 17010.000 | 31.87 | 19.75 | 51.62 | 74.00 | -22.38 | peak |

- Note: 1. Measurement = Reading Level + Correct Factor.
 2. If Peak Result complies with AV limit, AV Result is deemed to comply with AV limit.
 3. Peak: Peak detector.
 4. AVG: $VBW=1/Ton$, where: Ton is the transmitting duration.
 5. For the transmitting duration, please refer to clause 7.1.
 6. Filter losses were only considered in the spurious frequency bands and the authorized band was not corrected for High Pass Filter losses.
 7. Proper operation of the transmitter prior to adding the filter to the measurement chain.
 8. Since non-restricted band peak emissions are less than the average limit, they also comply with the -27dBm/MHz (68.2dBuV/m) limit.



HARMONICS AND SPURIOUS EMISSIONS (HIGH CHANNEL, VERTICAL)

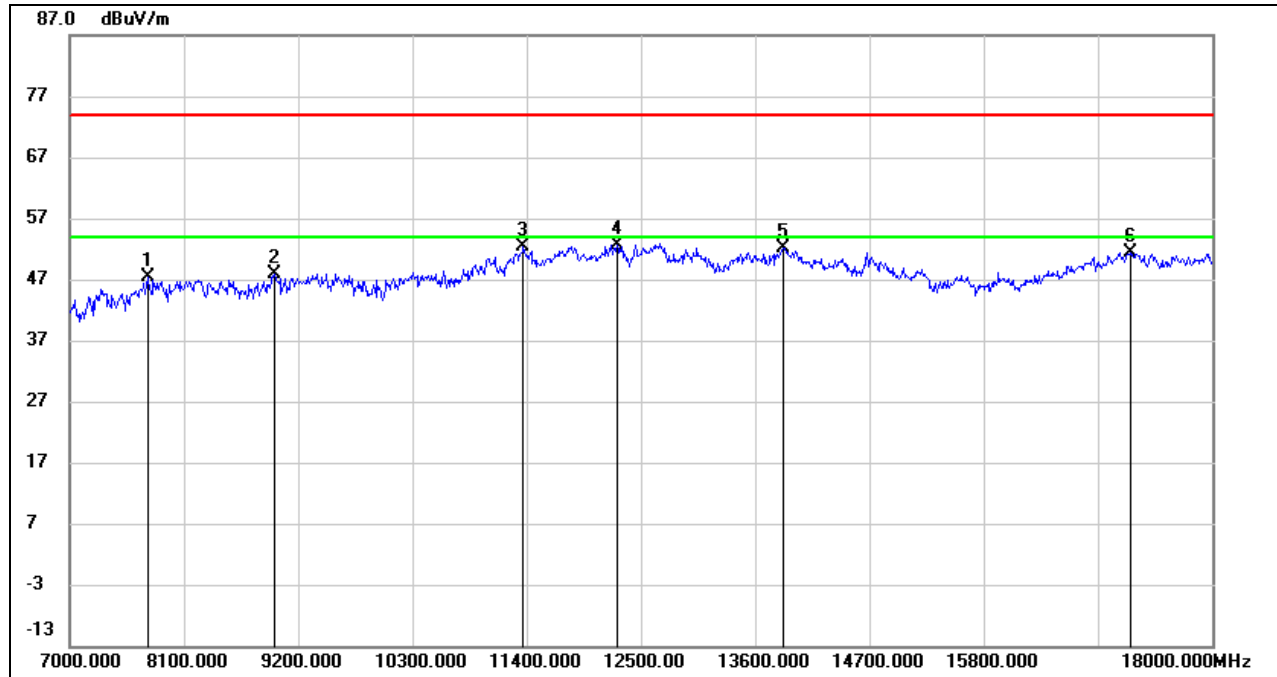

| No. | Frequency (MHz) | Reading (dBuV) | Correct (dB/m) | Result (dBuV/m) | Limit (dBuV/m) | Margin (dB) | Remark |
|-----|-----------------|----------------|----------------|-----------------|----------------|-------------|--------|
| 1 | 7748.000 | 38.67 | 8.64 | 47.31 | 74.00 | -26.69 | peak |
| 2 | 8969.000 | 36.97 | 10.90 | 47.87 | 74.00 | -26.13 | peak |
| 3 | 11367.000 | 35.56 | 16.89 | 52.45 | 74.00 | -21.55 | peak |
| 4 | 12269.000 | 34.71 | 17.96 | 52.67 | 74.00 | -21.33 | peak |
| 5 | 13875.000 | 32.34 | 19.81 | 52.15 | 74.00 | -21.85 | peak |
| 6 | 17208.000 | 30.17 | 21.16 | 51.33 | 74.00 | -22.67 | peak |

- Note:
1. Measurement = Reading Level + Correct Factor.
 2. If Peak Result complies with AV limit, AV Result is deemed to comply with AV limit.
 3. Peak: Peak detector.
 4. AVG: $VBW=1/Ton$, where: Ton is the transmitting duration.
 5. For the transmitting duration, please refer to clause 7.1.
 6. Filter losses were only considered in the spurious frequency bands and the authorized band was not corrected for High Pass Filter losses.
 7. Proper operation of the transmitter prior to adding the filter to the measurement chain.
 8. Since non-restricted band peak emissions are less than the average limit, they also comply with the -27dBm/MHz (68.2dBuV/m) limit.



UNII-3 BAND

HARMONICS AND SPURIOUS EMISSIONS (LOW CHANNEL, HORIZONTAL)

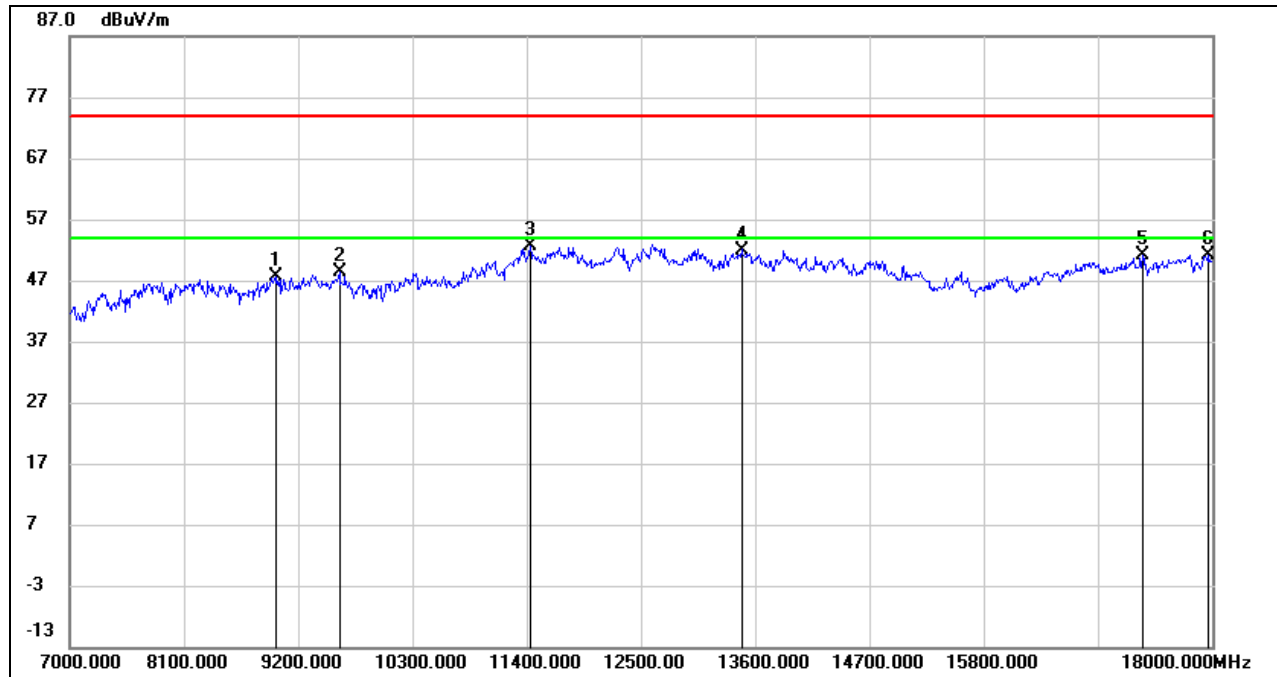

| No. | Frequency (MHz) | Reading (dBuV) | Correct (dB/m) | Result (dBuV/m) | Limit (dBuV/m) | Margin (dB) | Remark |
|-----|-----------------|----------------|----------------|-----------------|----------------|-------------|--------|
| 1 | 8991.000 | 36.38 | 11.13 | 47.51 | 74.00 | -26.49 | peak |
| 2 | 9596.000 | 36.40 | 11.98 | 48.38 | 74.00 | -25.62 | peak |
| 3 | 11433.000 | 35.41 | 17.17 | 52.58 | 74.00 | -21.42 | peak |
| 4 | 13468.000 | 32.58 | 19.42 | 52.00 | 74.00 | -22.00 | peak |
| 5 | 17329.000 | 30.13 | 21.02 | 51.15 | 74.00 | -22.85 | peak |
| 6 | 17967.000 | 26.57 | 24.61 | 51.18 | 74.00 | -22.82 | peak |

Note: 1. Measurement = Reading Level + Correct Factor.
 2. If Peak Result complies with AV limit, AV Result is deemed to comply with AV limit.
 3. Peak: Peak detector.
 4. Filter losses were only considered in the spurious frequency bands and the authorized band was not corrected for High Pass Filter losses.
 5. Proper operation of the transmitter prior to adding the filter to the measurement chain.
 6. Since non-restricted band peak emissions are less than the average limit, they also comply with the -27dBm/MHz (68.2dBuV/m) limit.



HARMONICS AND SPURIOUS EMISSIONS (LOW CHANNEL, VERTICAL)

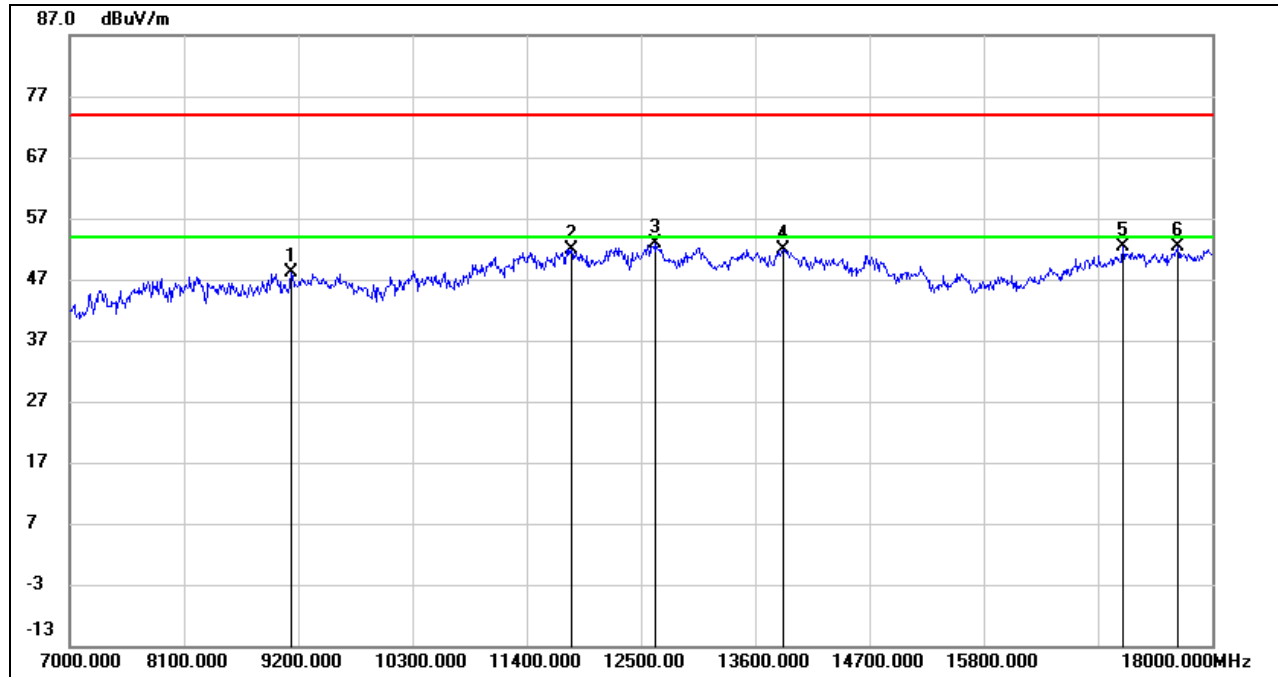

| No. | Frequency (MHz) | Reading (dBuV) | Correct (dB/m) | Result (dBuV/m) | Limit (dBuV/m) | Margin (dB) | Remark |
|-----|-----------------|----------------|----------------|-----------------|----------------|-------------|--------|
| 1 | 9134.000 | 37.50 | 10.55 | 48.05 | 74.00 | -25.95 | peak |
| 2 | 11829.000 | 33.54 | 18.40 | 51.94 | 74.00 | -22.06 | peak |
| 3 | 12632.000 | 34.62 | 18.17 | 52.79 | 74.00 | -21.21 | peak |
| 4 | 13875.000 | 32.14 | 19.81 | 51.95 | 74.00 | -22.05 | peak |
| 5 | 17142.000 | 31.56 | 20.74 | 52.30 | 74.00 | -21.70 | peak |
| 6 | 17670.000 | 29.55 | 22.82 | 52.37 | 74.00 | -21.63 | peak |

- Note: 1. Measurement = Reading Level + Correct Factor.
 2. If Peak Result complies with AV limit, AV Result is deemed to comply with AV limit.
 3. Peak: Peak detector.
 4. AVG: $VBW=1/Ton$, where: Ton is the transmitting duration.
 5. For the transmitting duration, please refer to clause 7.1.
 6. Filter losses were only considered in the spurious frequency bands and the authorized band was not corrected for High Pass Filter losses.
 7. Proper operation of the transmitter prior to adding the filter to the measurement chain.
 8. Since non-restricted band peak emissions are less than the average limit, they also comply with the -27dBm/MHz (68.2dBuV/m) limit.



8.4. SPURIOUS EMISSIONS (18 GHz ~ 26 GHz)

8.4.1. 802.11ac VHT80 MODE

SPURIOUS EMISSIONS (UNII-2A BAND LOW CHANNEL, HORIZONTAL, WORST-CASE CONFIGURATION)

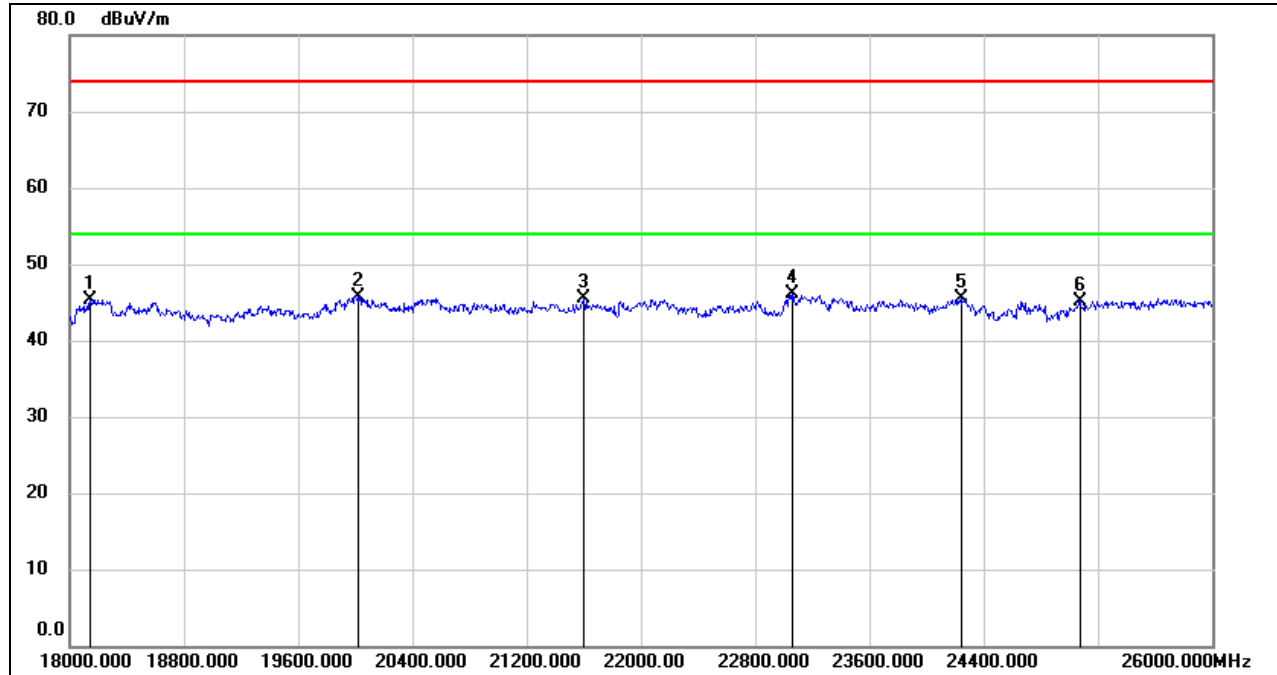

| No. | Frequency (MHz) | Reading (dBuV) | Correct (dB/m) | Result (dBuV/m) | Limit (dBuV/m) | Margin (dB) | Remark |
|-----|-----------------|----------------|----------------|-----------------|----------------|-------------|--------|
| 1 | 18144.000 | 50.77 | -5.48 | 45.29 | 74.00 | -28.71 | peak |
| 2 | 20024.000 | 51.25 | -5.47 | 45.78 | 74.00 | -28.22 | peak |
| 3 | 21600.000 | 50.02 | -4.54 | 45.48 | 74.00 | -28.52 | peak |
| 4 | 23064.000 | 49.49 | -3.42 | 46.07 | 74.00 | -27.93 | peak |
| 5 | 24248.000 | 48.32 | -2.83 | 45.49 | 74.00 | -28.51 | peak |
| 6 | 25072.000 | 47.17 | -1.97 | 45.20 | 74.00 | -28.80 | peak |

- Note: 1. Measurement = Reading Level + Correct Factor.
 2. If Peak Result complies with AV limit, AV Result is deemed to comply with AV limit.
 3. Peak: Peak detector.



SPURIOUS EMISSIONS (UNII-2A BAND LOW CHANNEL, VERTICAL, WORST-CASE CONFIGURATION)

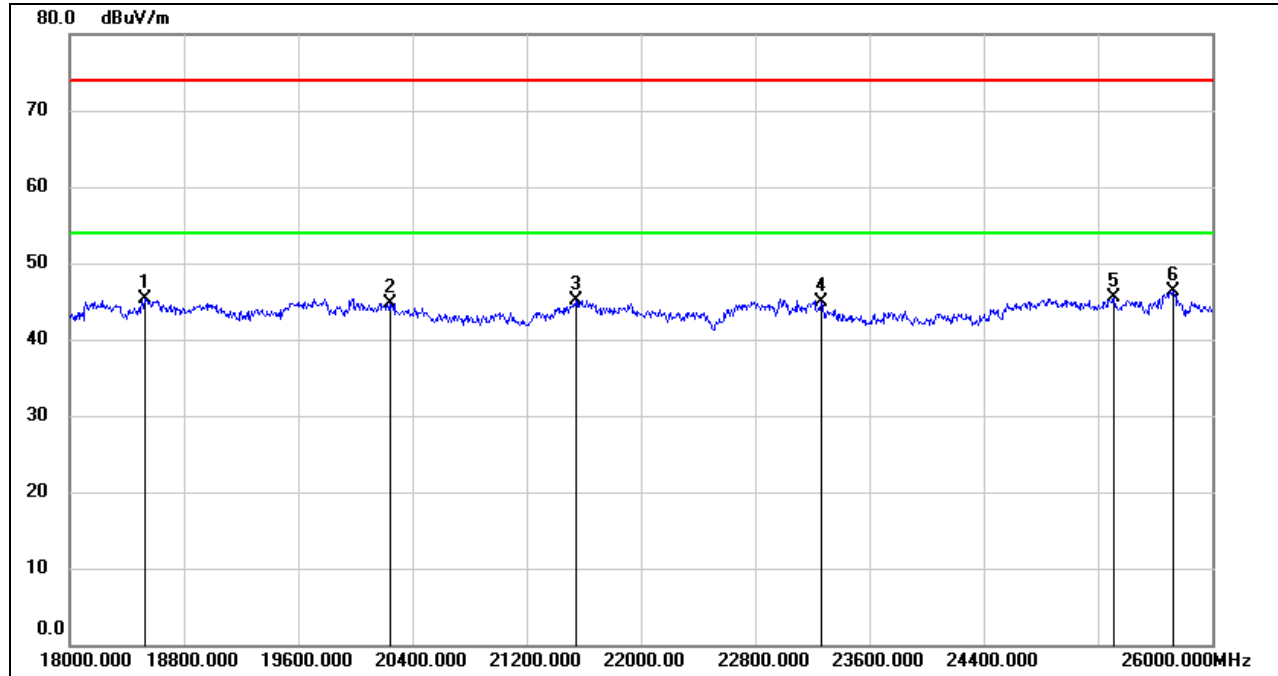

| No. | Frequency (MHz) | Reading (dBuV) | Correct (dB/m) | Result (dBuV/m) | Limit (dBuV/m) | Margin (dB) | Remark |
|-----|-----------------|----------------|----------------|-----------------|----------------|-------------|--------|
| 1 | 18528.000 | 50.61 | -5.26 | 45.35 | 74.00 | -28.65 | peak |
| 2 | 20240.000 | 50.32 | -5.61 | 44.71 | 74.00 | -29.29 | peak |
| 3 | 21544.000 | 49.76 | -4.63 | 45.13 | 74.00 | -28.87 | peak |
| 4 | 23264.000 | 48.26 | -3.36 | 44.90 | 74.00 | -29.10 | peak |
| 5 | 25312.000 | 47.20 | -1.70 | 45.50 | 74.00 | -28.50 | peak |
| 6 | 25728.000 | 47.11 | -0.72 | 46.39 | 74.00 | -27.61 | peak |

- Note: 1. Measurement = Reading Level + Correct Factor.
 2. If Peak Result complies with AV limit, AV Result is deemed to comply with AV limit.
 3. Peak: Peak detector.

Note: All the modes and antennas had been tested, but only the worst data was recorded in the report.



8.5. SPURIOUS EMISSIONS (26 GHz ~ 40 GHz)

8.5.1. 802.11ac VHT80 MODE

SPURIOUS EMISSIONS (UNII-2A BAND LOW CHANNEL, HORIZONTAL, WORST-CASE CONFIGURATION)

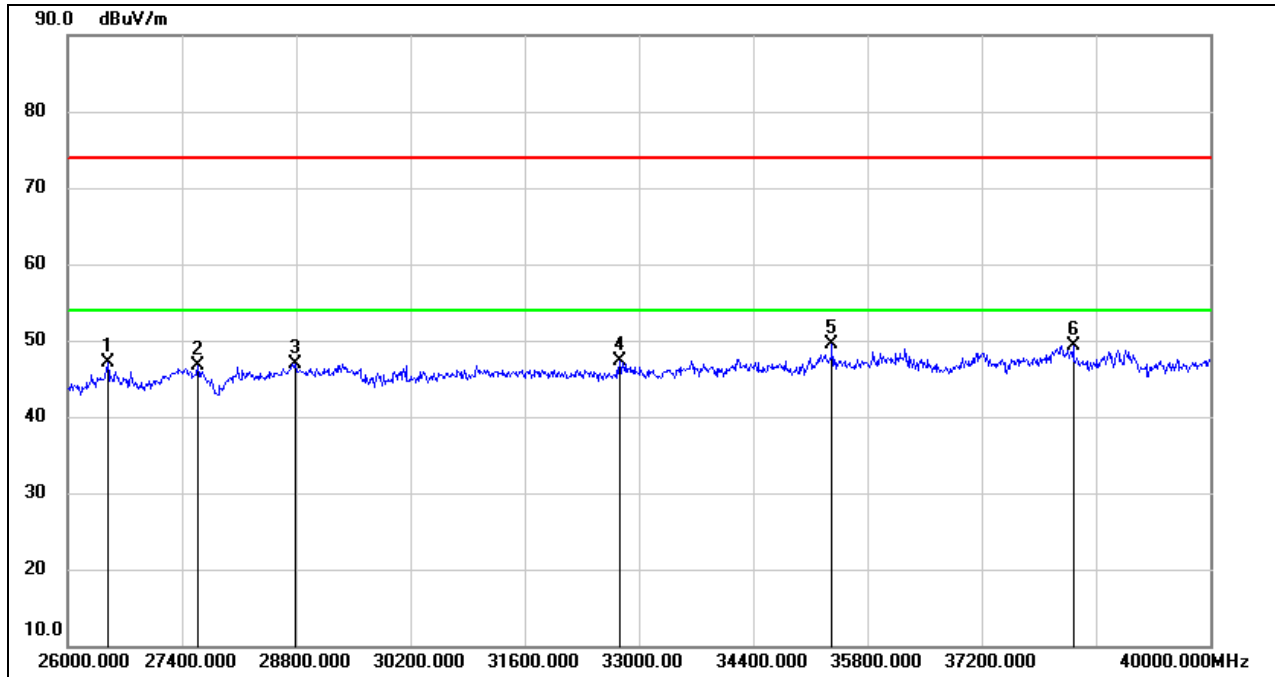

| No. | Frequency (MHz) | Reading (dBuV) | Correct (dB/m) | Result (dBuV/m) | Limit (dBuV/m) | Margin (dB) | Remark |
|-----|-----------------|----------------|----------------|-----------------|----------------|-------------|--------|
| 1 | 26490.000 | 51.79 | -4.74 | 47.05 | 74.00 | -26.95 | peak |
| 2 | 27596.000 | 50.21 | -3.46 | 46.75 | 74.00 | -27.25 | peak |
| 3 | 28786.000 | 47.49 | -0.64 | 46.85 | 74.00 | -27.15 | peak |
| 4 | 32762.000 | 48.45 | -1.21 | 47.24 | 74.00 | -26.76 | peak |
| 5 | 35366.000 | 46.90 | 2.59 | 49.49 | 74.00 | -24.51 | peak |
| 6 | 38320.000 | 45.56 | 3.77 | 49.33 | 74.00 | -24.67 | peak |

Note: 1. Measurement = Reading Level + Correct Factor.
 2. If Peak Result complies with AV limit, AV Result is deemed to comply with AV limit.
 3. Peak: Peak detector.



SPURIOUS EMISSIONS (UNII-2A BAND LOW CHANNEL, VERTICAL, WORST-CASE CONFIGURATION)

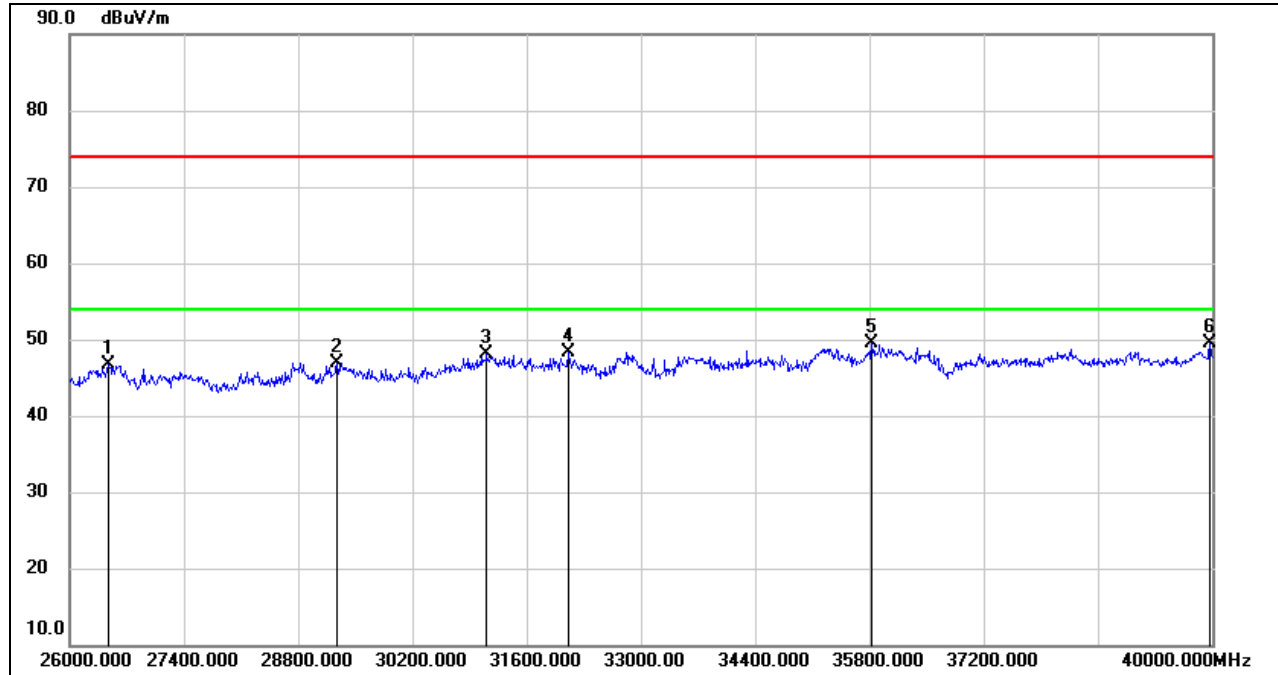

| No. | Frequency (MHz) | Reading (dBuV) | Correct (dB/m) | Result (dBuV/m) | Limit (dBuV/m) | Margin (dB) | Remark |
|-----|-----------------|----------------|----------------|-----------------|----------------|-------------|--------|
| 1 | 26476.000 | 51.53 | -4.78 | 46.75 | 74.00 | -27.25 | peak |
| 2 | 29276.000 | 48.01 | -1.01 | 47.00 | 74.00 | -27.00 | peak |
| 3 | 31110.000 | 48.83 | -0.75 | 48.08 | 74.00 | -25.92 | peak |
| 4 | 32104.000 | 49.99 | -1.75 | 48.24 | 74.00 | -25.76 | peak |
| 5 | 35828.000 | 45.75 | 3.67 | 49.42 | 74.00 | -24.58 | peak |
| 6 | 39972.000 | 44.45 | 5.13 | 49.58 | 74.00 | -24.42 | peak |

- Note: 1. Measurement = Reading Level + Correct Factor.
 2. If Peak Result complies with AV limit, AV Result is deemed to comply with AV limit.
 3. Peak: Peak detector.

Note: All the modes and antennas had been tested, but only the worst data was recorded in the report.



8.6. SPURIOUS EMISSIONS (30 MHz ~ 1 GHz)

8.6.1. 802.11ac VHT80 MODE

SPURIOUS EMISSIONS (UNII-2A BAND LOW CHANNEL, HORIZONTAL, WORST-CASE CONFIGURATION)

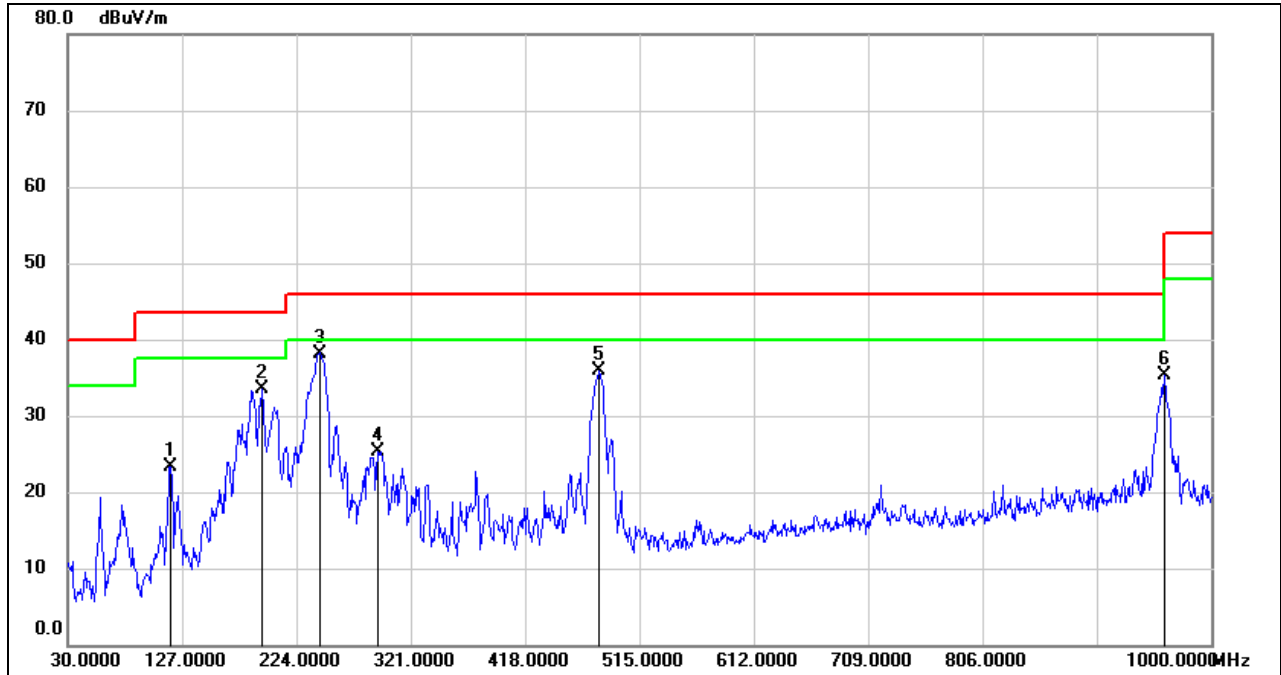

| No. | Frequency (MHz) | Reading (dBuV) | Correct (dB/m) | Result (dBuV/m) | Limit (dBuV/m) | Margin (dB) | Remark |
|-----|-----------------|----------------|----------------|-----------------|----------------|-------------|--------|
| 1 | 117.3000 | 43.38 | -20.03 | 23.35 | 43.50 | -20.15 | QP |
| 2 | 194.9000 | 50.03 | -16.49 | 33.54 | 43.50 | -9.96 | QP |
| 3 | 243.4000 | 57.28 | -19.08 | 38.20 | 46.00 | -7.80 | QP |
| 4 | 292.8700 | 41.10 | -15.73 | 25.37 | 46.00 | -20.63 | QP |
| 5 | 481.0500 | 47.63 | -11.78 | 35.85 | 46.00 | -10.15 | QP |
| 6 | 960.2300 | 39.92 | -4.54 | 35.38 | 54.00 | -18.62 | QP |

- Note: 1. Result Level = Read Level + Correct Factor.
 2. If Peak Result complies with QP limit, QP Result is deemed to comply with QP limit.
 3. Test setup: RBW: 120 kHz, VBW: 300 kHz, Sweep time: auto.



SPURIOUS EMISSIONS (UNII-2A BAND LOW CHANNEL, VERTICAL, WORST-CASE CONFIGURATION)

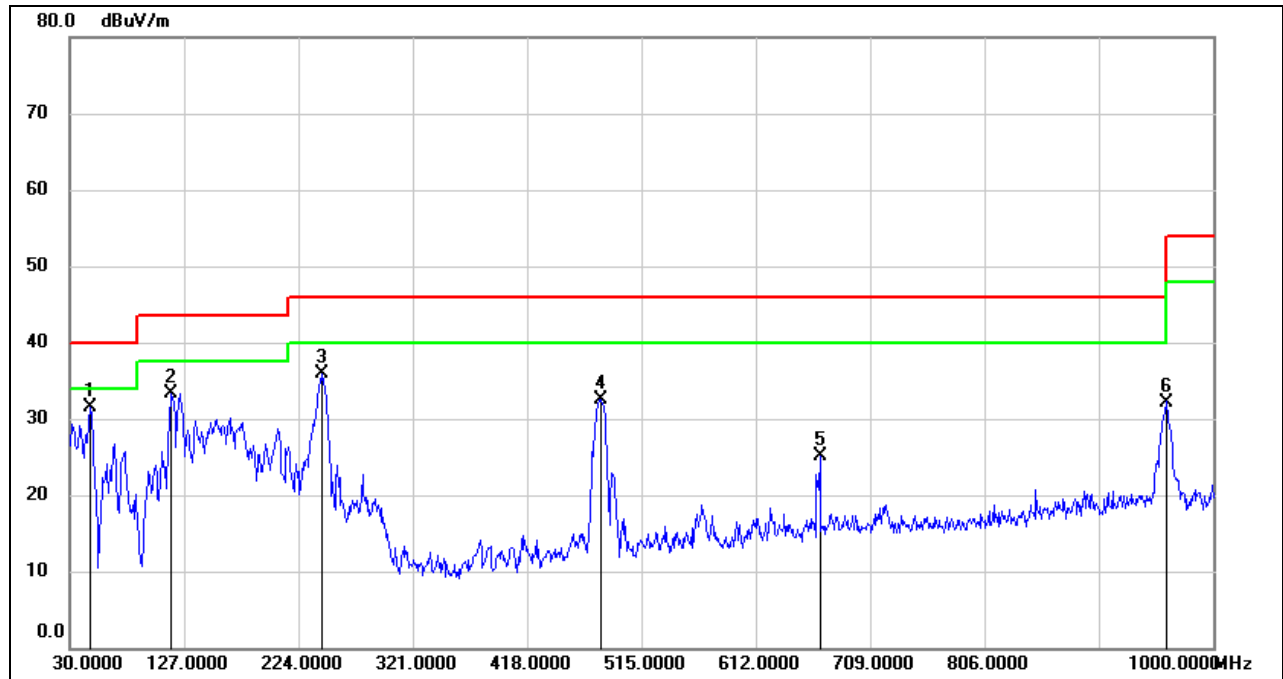

| No. | Frequency (MHz) | Reading (dBuV) | Correct (dB/m) | Result (dBuV/m) | Limit (dBuV/m) | Margin (dB) | Remark |
|-----|-----------------|----------------|----------------|-----------------|----------------|-------------|--------|
| 1 | 47.4600 | 51.98 | -20.55 | 31.43 | 40.00 | -8.57 | QP |
| 2 | 116.3300 | 53.38 | -20.08 | 33.30 | 43.50 | -10.20 | QP |
| 3 | 244.3700 | 54.98 | -19.07 | 35.91 | 46.00 | -10.09 | QP |
| 4 | 480.0800 | 44.32 | -11.79 | 32.53 | 46.00 | -13.47 | QP |
| 5 | 666.3200 | 33.75 | -8.65 | 25.10 | 46.00 | -20.90 | QP |
| 6 | 960.2300 | 36.74 | -4.54 | 32.20 | 54.00 | -21.80 | QP |

- Note: 1. Result Level = Read Level + Correct Factor.
 2. If Peak Result complies with QP limit, QP Result is deemed to comply with QP limit.
 3. Test setup: RBW: 120 kHz, VBW: 300 kHz, Sweep time: auto

Note: All the modes and antennas had been tested, but only the worst data was recorded in the report.

8.7. SPURIOUS EMISSIONS BELOW 30 MHz

8.7.1. 802.11ac VHT80 MODE

SPURIOUS EMISSIONS (UNII-2A BAND LOW CHANNEL, LOOP ANTENNA FACE ON TO THE EUT, WORST-CASE CONFIGURATION)

9 kHz~ 150 kHz

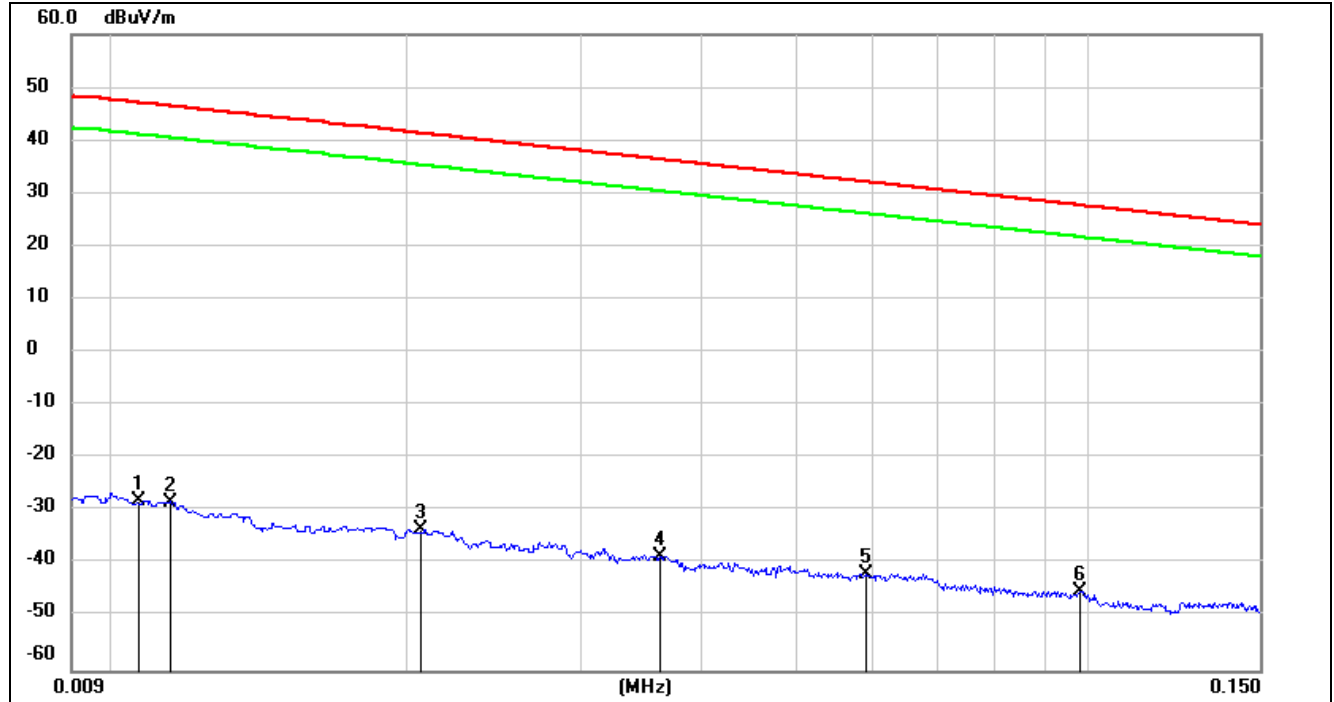

| No. | Frequency (MHz) | Reading (dBuV) | Correct (dB/m) | FCC Result (dBuV/m) | FCC Limit (dBuV/m) | ISED Result (dBuA/m) | ISED Limit (dBuA/m) | Margin (dB) | Remark |
|-----|--------------------|-------------------|-------------------|------------------------|-----------------------|-------------------------|------------------------|----------------|--------|
| 1 | 0.0106 | 73.38 | -101.39 | -28.01 | 47.09 | -79.51 | -4.41 | -75.10 | peak |
| 2 | 0.0114 | 73.00 | -101.40 | -28.4 | 46.46 | -79.90 | -5.04 | -74.86 | peak |
| 3 | 0.0206 | 67.92 | -101.35 | -33.43 | 41.32 | -84.93 | -10.18 | -74.75 | peak |
| 4 | 0.0362 | 63.01 | -101.42 | -38.41 | 36.43 | -89.91 | -15.07 | -74.84 | peak |
| 5 | 0.0589 | 59.81 | -101.52 | -41.71 | 32.2 | -93.21 | -19.30 | -73.91 | peak |
| 6 | 0.0981 | 56.77 | -101.78 | -45.01 | 27.77 | -96.51 | -23.73 | -72.78 | peak |

Note: 1. Measurement = Reading Level + Correct Factor.

2. If Peak Result complies with AV and QP limit, AV and QP Result are deemed to comply with AV limit.

3. All 3 polarizations (Horizontal, Face-on and Face-off) of the loop antenna had been tested, but only the worst data recorded in the report.

4. $\text{dBuA/m} = \text{dBuV/m} - 20\log_{10}(120\pi) = \text{dBuV/m} - 51.5$.



150 kHz ~ 490 kHz

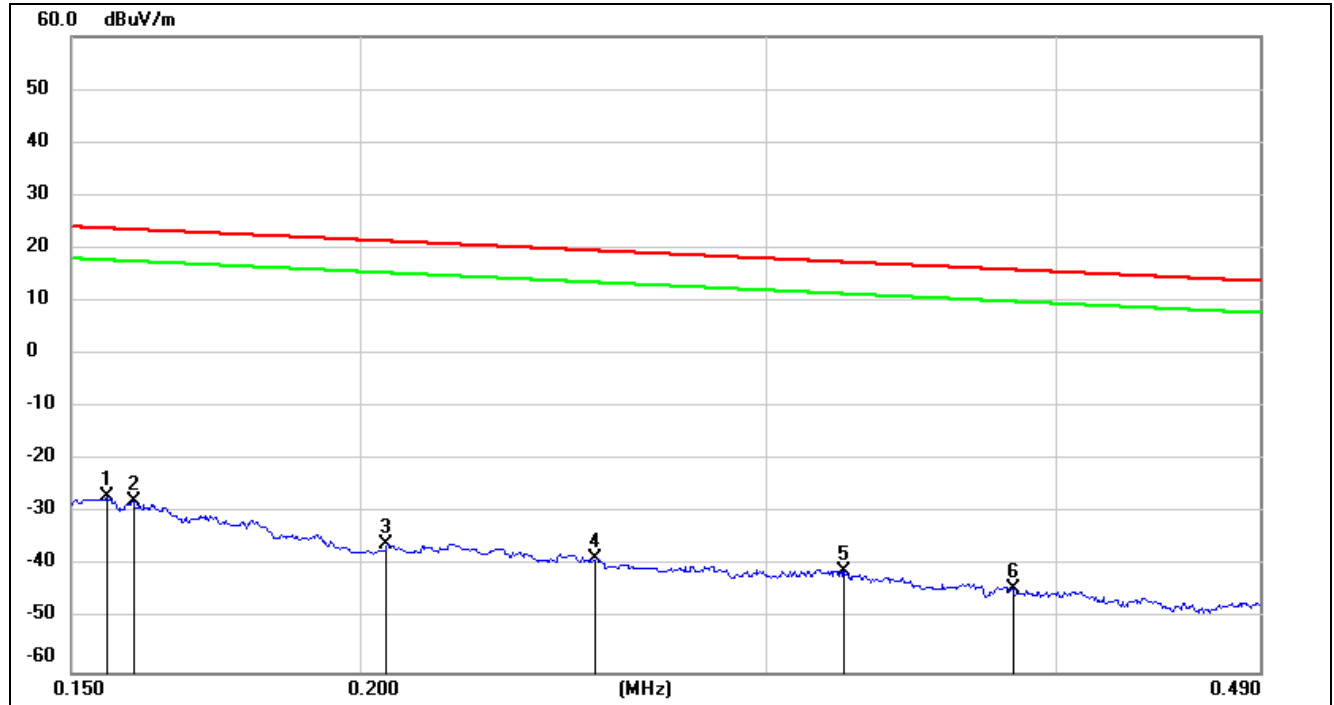

| No. | Frequency (MHz) | Reading (dBuV) | Correct (dB/m) | FCC Result (dBuV/m) | FCC Limit (dBuV/m) | ISED Result (dBuA/m) | ISED Limit (dBuA/m) | Margin (dB) | Remark |
|-----|--------------------|-------------------|-------------------|---------------------------|--------------------------|----------------------------|---------------------------|----------------|--------|
| 1 | 0.1554 | 74.77 | -101.65 | -26.88 | 23.77 | -78.38 | -27.73 | -50.65 | peak |
| 2 | 0.1595 | 73.86 | -101.65 | -27.79 | 23.55 | -79.29 | -27.95 | -51.34 | peak |
| 3 | 0.2053 | 65.79 | -101.73 | -35.94 | 21.35 | -87.44 | -30.15 | -57.29 | peak |
| 4 | 0.2530 | 63.14 | -101.80 | -38.66 | 19.54 | -90.16 | -31.96 | -58.20 | peak |
| 5 | 0.3240 | 60.87 | -101.88 | -41.01 | 17.39 | -92.51 | -34.11 | -58.40 | peak |
| 6 | 0.3830 | 57.70 | -101.94 | -44.24 | 15.94 | -95.74 | -35.56 | -60.18 | peak |

- Note: 1. Measurement = Reading Level + Correct Factor.
 2. If Peak Result complies with AV and QP limit, AV and QP Result are deemed to comply with AV limit.
 3. All 3 polarizations (Horizontal, Face-on and Face-off) of the loop antenna had been tested, but only the worst data recorded in the report.
 4. $\text{dBuA/m} = \text{dBuV/m} - 20\log_{10}(120\pi) = \text{dBuV/m} - 51.5$.

490 kHz ~ 30 MHz

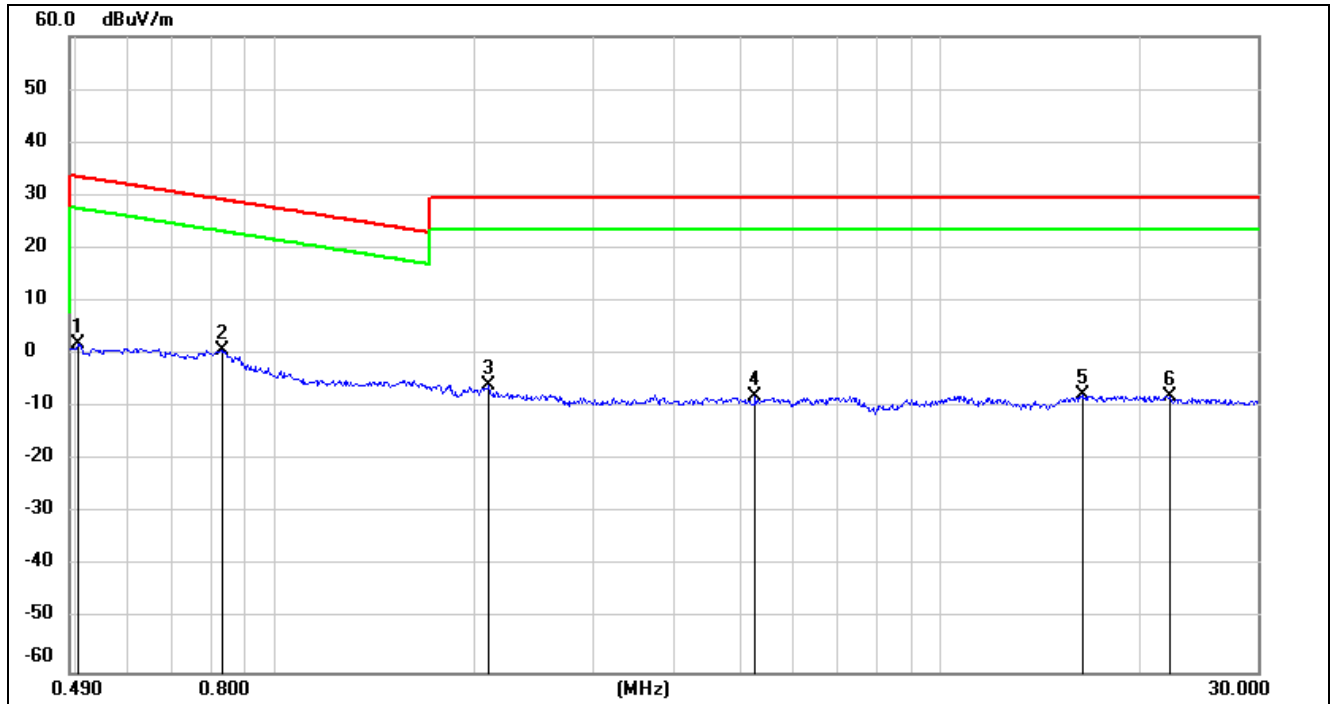

| No. | Frequency (MHz) | Reading (dBuV) | Correct (dB/m) | FCC Result (dBuV/m) | FCC Limit (dBuV/m) | ISED Result (dBuA/m) | ISED Limit (dBuA/m) | Margin (dB) | Remark |
|-----|--------------------|-------------------|-------------------|---------------------------|--------------------------|----------------------------|---------------------------|----------------|--------|
| 1 | 0.5039 | 63.94 | -62.07 | 1.87 | 33.56 | -49.63 | -17.94 | -31.69 | peak |
| 2 | 0.8296 | 62.94 | -62.17 | 0.77 | 29.23 | -50.73 | -22.27 | -28.46 | peak |
| 3 | 2.0939 | 55.89 | -61.79 | -5.9 | 29.54 | -57.40 | -21.96 | -35.44 | peak |
| 4 | 5.2705 | 53.54 | -61.45 | -7.91 | 29.54 | -59.41 | -21.96 | -37.45 | peak |
| 5 | 16.3959 | 53.17 | -60.96 | -7.79 | 29.54 | -59.29 | -21.96 | -37.33 | peak |
| 6 | 22.1503 | 52.70 | -60.67 | -7.97 | 29.54 | -59.47 | -21.96 | -37.51 | peak |

- Note: 1. Measurement = Reading Level + Correct Factor.
 2. If Peak Result complies with AV and QP limit, AV and QP Result are deemed to comply with AV limit.
 3. All 3 polarizations (Horizontal, Face-on and Face-off) of the loop antenna had been tested, but only the worst data recorded in the report.
 4. $\text{dBuA/m} = \text{dBuV/m} - 20\log_{10}(120\pi) = \text{dBuV/m} - 51.5$.

Note: All the modes and antennas had been tested, but only the worst data was recorded in the report.

9. AC POWER LINE CONDUCTED EMISSIONS

LIMITS

Please refer to CFR 47 FCC §15.207 (a) and ISED RSS-Gen Clause 8.8

| FREQUENCY (MHz) | Quasi-peak | Average |
|-----------------|------------|-----------|
| 0.15 -0.5 | 66 - 56 * | 56 - 46 * |
| 0.50 -5.0 | 56.00 | 46.00 |
| 5.0 -30.0 | 60.00 | 50.00 |

TEST SETUP AND PROCEDURE

Refer to ANSI C63.10-2013 clause 6.2.

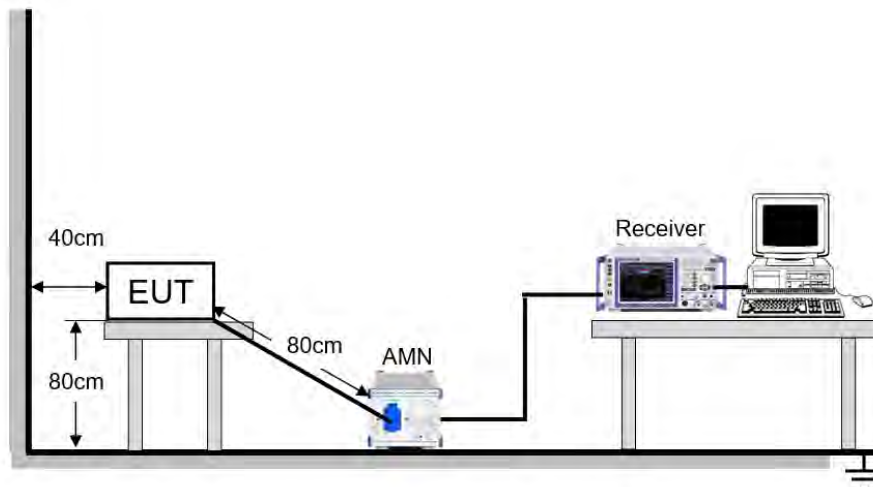

The EUT is put on a table of non-conducting material that is 80 cm high. The vertical conducting wall of shielding is located 40 cm to the rear of the EUT. The power line of the EUT is connected to the AC mains through a Artificial Mains Network (A.M.N.). A EMI Measurement Receiver (R&S Test Receiver ESR3) is used to test the emissions from both sides of AC line. According to the requirements in Section 6.2 of ANSI C63.10-2013. Conducted emissions from the EUT measured in the frequency range between 0.15 MHz and 30 MHz using CISPR Quasi-Peak and average detector mode. The bandwidth of EMI test receiver is set at 9 kHz.

The arrangement of the equipment is installed to meet the standards and operating in a manner, which tends to maximize its emission characteristics in a normal application.

TEST ENVIRONMENT

| | | | |
|---------------------|---------|-------------------|-----------------|
| Temperature | 24.3 °C | Relative Humidity | 69.1 % |
| Atmosphere Pressure | 101 kPa | Test Voltage | AC 120 V, 60 Hz |



RESULTS

9.1.1. 802.11ac VHT80 MODE

LINE L RESULTS (UNII-2A BAND LOW CHANNEL, WORST-CASE CONFIGURATION)

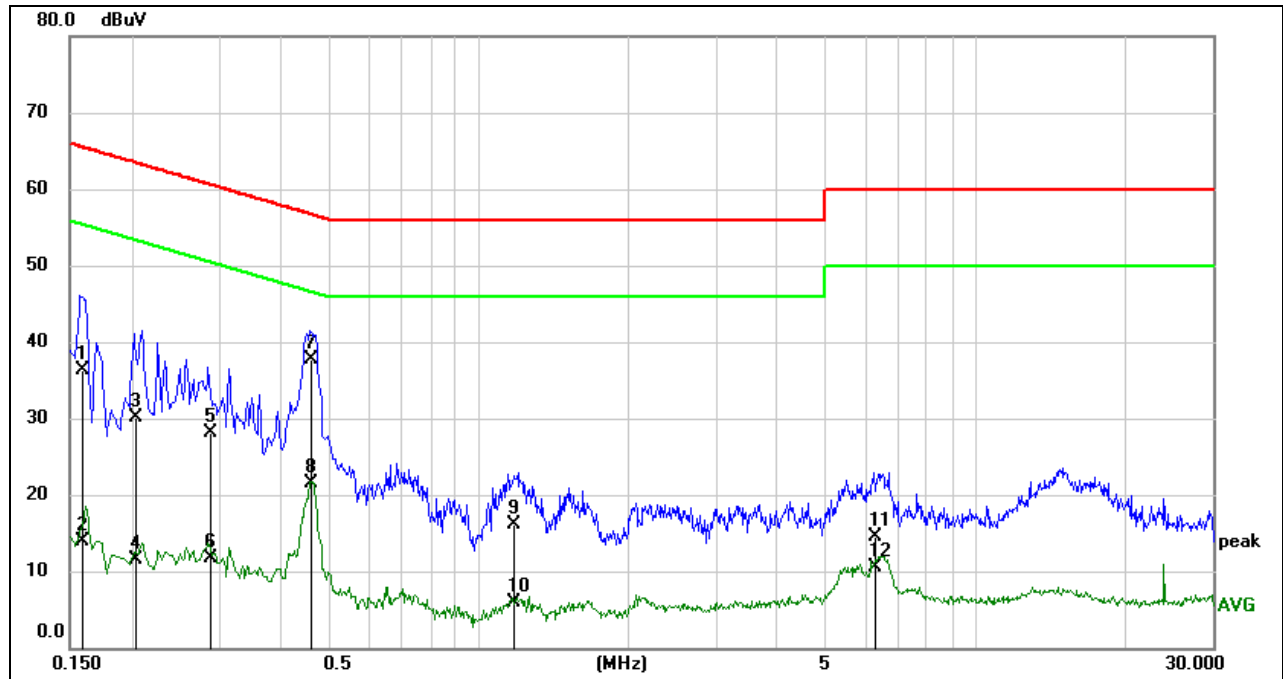

| No. | Frequency (MHz) | Reading (dBuV) | Correct (dB) | Result (dBuV) | Limit (dBuV) | Margin (dB) | Remark |
|-----|-----------------|----------------|--------------|---------------|--------------|-------------|--------|
| 1 | 0.1594 | 26.79 | 9.59 | 36.38 | 65.50 | -29.12 | QP |
| 2 | 0.1594 | 4.38 | 9.59 | 13.97 | 55.50 | -41.53 | AVG |
| 3 | 0.2051 | 20.47 | 9.59 | 30.06 | 63.40 | -33.34 | QP |
| 4 | 0.2051 | 1.86 | 9.59 | 11.45 | 53.40 | -41.95 | AVG |
| 5 | 0.2884 | 18.43 | 9.59 | 28.02 | 60.57 | -32.55 | QP |
| 6 | 0.2884 | 2.03 | 9.59 | 11.62 | 50.57 | -38.95 | AVG |
| 7 | 0.4599 | 28.17 | 9.60 | 37.77 | 56.69 | -18.92 | QP |
| 8 | 0.4599 | 11.93 | 9.60 | 21.53 | 46.69 | -25.16 | AVG |
| 9 | 1.1712 | 6.53 | 9.61 | 16.14 | 56.00 | -39.86 | QP |
| 10 | 1.1712 | -3.68 | 9.61 | 5.93 | 46.00 | -40.07 | AVG |
| 11 | 6.2920 | 4.95 | 9.64 | 14.59 | 60.00 | -45.41 | QP |
| 12 | 6.2920 | 0.88 | 9.64 | 10.52 | 50.00 | -39.48 | AVG |

Note: 1. Result = Reading + Correct Factor.
 2. If QP Result complies with AV limit, AV Result is deemed to comply with AV limit.
 3. Test setup: RBW: 200 Hz (9 kHz ~ 150 kHz), 9 kHz (150 kHz ~ 30 MHz).
 4. Step size: 80 Hz (0.009 MHz ~ 0.15 MHz), 4 kHz (0.15 MHz ~ 30 MHz), Scan time: auto.



LINE N RESULTS (UNII-2A BAND LOW CHANNEL, WORST-CASE CONFIGURATION)

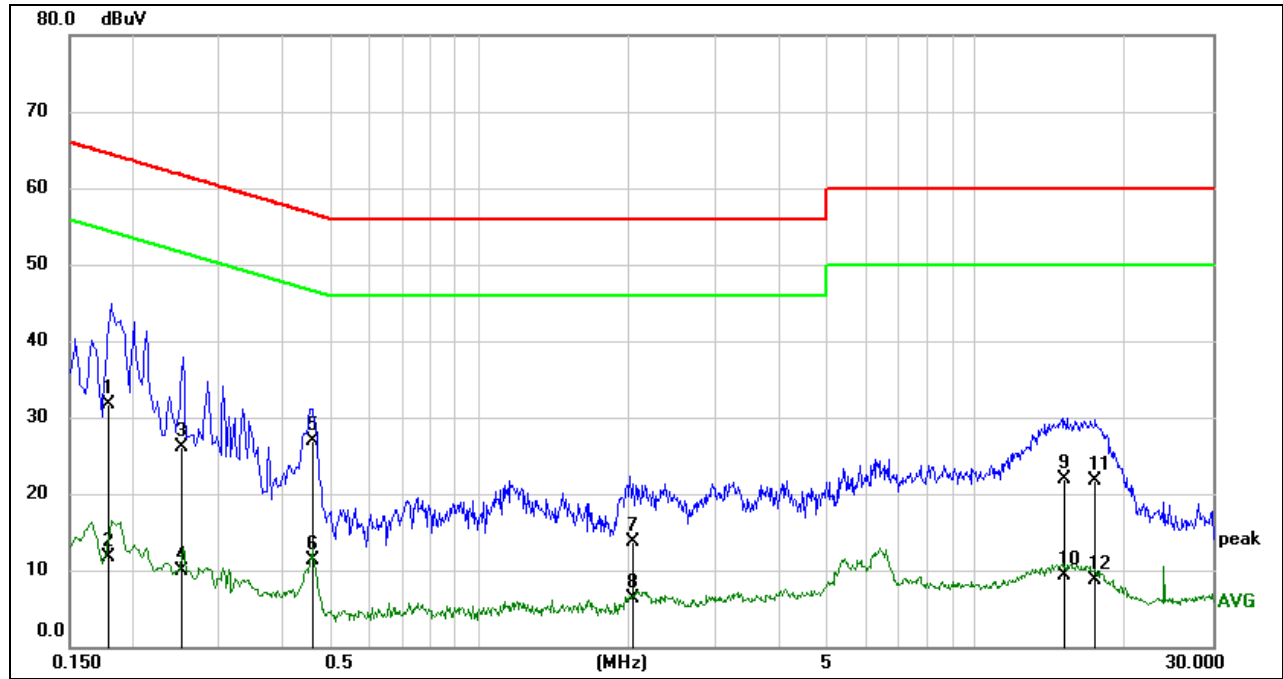

| No. | Frequency (MHz) | Reading (dBuV) | Correct (dB) | Result (dBuV) | Limit (dBuV) | Margin (dB) | Remark |
|-----|-----------------|----------------|--------------|---------------|--------------|-------------|--------|
| 1 | 0.1793 | 22.19 | 9.59 | 31.78 | 64.52 | -32.74 | QP |
| 2 | 0.1793 | 2.20 | 9.59 | 11.79 | 54.52 | -42.73 | AVG |
| 3 | 0.2512 | 16.47 | 9.59 | 26.06 | 61.72 | -35.66 | QP |
| 4 | 0.2512 | 0.37 | 9.59 | 9.96 | 51.72 | -41.76 | AVG |
| 5 | 0.4598 | 17.30 | 9.60 | 26.90 | 56.70 | -29.80 | QP |
| 6 | 0.4598 | 1.69 | 9.60 | 11.29 | 46.70 | -35.41 | AVG |
| 7 | 2.0614 | 4.09 | 9.63 | 13.72 | 56.00 | -42.28 | QP |
| 8 | 2.0614 | -3.39 | 9.63 | 6.24 | 46.00 | -39.76 | AVG |
| 9 | 15.0260 | 12.20 | 9.66 | 21.86 | 60.00 | -38.14 | QP |
| 10 | 15.0260 | -0.29 | 9.66 | 9.37 | 50.00 | -40.63 | AVG |
| 11 | 17.4307 | 12.00 | 9.74 | 21.74 | 60.00 | -38.26 | QP |
| 12 | 17.4307 | -1.05 | 9.74 | 8.69 | 50.00 | -41.31 | AVG |

Note: 1. Result = Reading + Correct Factor.
 2. If QP Result complies with AV limit, AV Result is deemed to comply with AV limit.
 3. Test setup: RBW: 200 Hz (9 kHz ~ 150 kHz), 9 kHz (150 kHz ~ 30 MHz).
 4. Step size: 80 Hz (0.009 MHz ~ 0.15 MHz), 4 kHz (0.15 MHz ~ 30 MHz), Scan time: auto.

Note: All the modes had been tested, but only the worst data was recorded in the report.

10. FREQUENCY STABILITY

LIMITS

The frequency of the carrier signal shall be maintained within band of operation.

TEST PROCEDURE

1. The EUT was placed inside an environmental chamber as the temperature in the chamber was varied between 0 °C ~ 70 °C (declared by customer).
2. The temperature was incremented by 10 °C intervals and the unit allowed to stabilize at each temperature before each measurement. The center frequency of the transmitting channel was evaluated at each temperature and the frequency deviation from the channel's center frequency was recorded.
3. The primary supply voltage is varied from 85 % to 115 % of the nominal value for non hand-carried battery and AC powered equipment. For hand-carried, battery-powered equipment, primary supply voltage is reduced to the battery operating end point which shall be specified by the manufacturer.

Connect the EUT to the spectrum analyser and use the following settings:

| | |
|------------------|--|
| Center Frequency | The center frequency of the channel under test |
| Detector | Peak |
| RBW | 10 kHz |
| VBW | $\geq 3 \times \text{RBW}$ |
| Span | Encompass the entire emissions bandwidth (EBW) of the signal |
| Trace | Max hold |
| Sweep time | Auto |

4. While maintaining a constant temperature inside the environmental chamber, turn the EUT on and record the operating frequency at startup, and at 2 minutes, 5minutes, and 10 minutes after the EUT is energized.
5. Allow the trace to stabilize, find the peak value of the power envelope and record the frequency, then calculated the frequency drift.

TEST SETUP

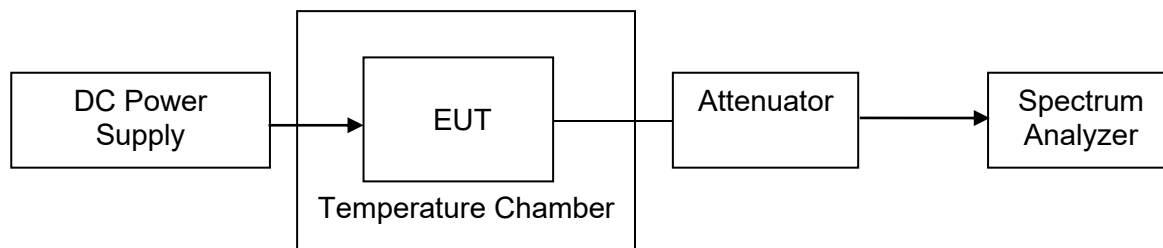



TEST ENVIRONMENT

| | Normal Test Conditions | Extreme Test Conditions |
|----------------------|---|--|
| Relative Humidity | 20 % - 75 % | / |
| Atmospheric Pressure | 100 kPa ~102 kPa | / |
| Temperature | T _N (Normal Temperature): 25.1 °C | T _L (Low Temperature): 0 °C |
| | | T _H (High Temperature): 40 °C |
| Supply Voltage | V _N (Normal Voltage): DC 3.3 V | V _L (Low Voltage): DC 2.97 V |
| | | V _H (High Voltage): DC 3.63 V |

RESULTS

Please refer to Appendix G.

11. DYNAMIC FREQUENCY SELECTION

APPLICABILITY OF DFS REQUIREMENTS

A U-NII network will employ a DFS function to detect signals from radar systems and to avoid co-channel operation with these systems. This applies to the 5250-5350 MHz and/or 5470-5725 MHz bands.

Within the context of the operation of the DFS function, a U-NII device will operate in either Master Mode or Client Mode. U-NII devices operating in Client Mode can only operate in a network controlled by a U-NII device operating in Master Mode.

Table 1: Applicability of DFS Requirements Prior to Use of a Channel

| Requirement | Operational Mode | | |
|---------------------------------|---------------------------------|--|--|
| | <input type="checkbox"/> Master | <input checked="" type="checkbox"/> Client Without Radar Detection | <input type="checkbox"/> Client With Radar Detection |
| Non-Occupancy Period | Yes | Not required | Yes |
| DFS Detection Threshold | Yes | Not required | Yes |
| Channel Availability Check Time | Yes | Not required | Not required |
| U-NII Detection Bandwidth | Yes | Not required | Yes |

Table 2: Applicability of DFS requirements during normal operation

| Requirement | Operational Mode | |
|-----------------------------------|---|--|
| | <input type="checkbox"/> Master Device or Client with Radar Detection | <input checked="" type="checkbox"/> Client Without Radar Detection |
| DFS Detection Threshold | Yes | Not required |
| Channel Closing Transmission Time | Yes | Yes |
| Channel Move Time | Yes | Yes |
| U-NII Detection Bandwidth | Yes | Not required |

| Additional requirements for devices with multiple bandwidth modes | <input type="checkbox"/> Master Device or Client with Radar Detection | <input checked="" type="checkbox"/> Client Without Radar Detection |
|---|---|--|
| U-NII Detection Bandwidth and Statistical Performance Check | All BW modes must be tested | Not required |
| Channel Move Time and Channel Closing Transmission Time | Test using widest BW mode available | Test using the widest BW mode available for the link |
| All other tests | Any single BW mode | Not required |

Note: Frequencies selected for statistical performance check should include several frequencies within the radar detection bandwidth and frequencies near the edge of the radar detection bandwidth. For 802.11 devices it is suggested to select frequencies in each of the bonded 20 MHz channels and the channel center frequency.

LIMITS

(1) DFS Detection Thresholds

Table 3: DFS Detection Thresholds for Master Devices and Client Devices With Radar Detection

| Maximum Transmit Power | Value (See Notes 1, 2, and 3) |
|--|-------------------------------|
| EIRP \geq 200 milliwatt | -64 dBm |
| EIRP < 200 milliwatt and power spectral density < 10 dBm/MHz | -62 dBm |
| EIRP < 200 milliwatt that do not meet the power spectral density requirement | -64 dBm |

Note 1: This is the level at the input of the receiver assuming a 0 dBi receive antenna.
 Note 2: Throughout these test procedures an additional 1 dB has been added to the amplitude of the test transmission waveforms to account for variations in measurement equipment. This will ensure that the test signal is at or above the detection threshold level to trigger a DFS response.
 Note3: EIRP is based on the highest antenna gain. For MIMO devices refer to KDB Publication 662911 D01.

(2) DFS Response Requirements

Table 4: DFS Response Requirement Values

| Parameter | Value |
|-----------------------------------|---|
| Non-occupancy period | Minimum 30 minutes |
| Channel Availability Check Time | 60 seconds |
| Channel Move Time | 10 seconds See Note 1. |
| Channel Closing Transmission Time | 200 milliseconds + an aggregate of 60 milliseconds over remaining 10 second period. See Notes 1 and 2. |
| U-NII Detection Bandwidth | Minimum 100% of the U-NII 99% transmission power bandwidth. See Note 3. |

Note 1: Channel Move Time and the Channel Closing Transmission Time should be performed with Radar Type 0. The measurement timing begins at the end of the Radar Type 0 burst.
 Note 2: The Channel Closing Transmission Time is comprised of 200 milliseconds starting at the beginning of the Channel Move Time plus any additional intermittent control signals required facilitating a Channel move (an aggregate of 60 milliseconds) during the remainder of the 10 second period. The aggregate duration of control signals will not count quiet periods in between transmissions.
 Note 3: During the U-NII Detection Bandwidth detection test, radar type 0 should be used. For each frequency step the minimum percentage of detection is 90 percent. Measurements are performed with no data traffic.

PARAMETERS OF RADAR TEST WAVEFORMS

This section provides the parameters for required test waveforms, minimum percentage of successful detections, and the minimum number of trials that must be used for determining DFS conformance. Step intervals of 0.1 microsecond for Pulse Width, 1 microsecond for PRI, 1 MHz for chirp width and 1 for the number of pulses will be utilized for the random determination of specific test waveforms.

Table 5 Short Pulse Radar Test Waveforms

| Radar Type | Pulse Width (µsec) | PRI (µsec) | Number of Pulses | Minimum Percentage of Successful Detection | Minimum Number of Trials |
|---|--------------------|------------|---|--|--------------------------|
| 0 | 1 | 1428 | 18 | See Note 1 | See Note 1 |
| 1 | 1 | Test A | Roundup $\left\{ \begin{matrix} \frac{1}{360} \\ \frac{19 \cdot 10^9}{PRI_{\mu sec}} \end{matrix} \right\}$ | 60% | 30 |
| | | Test B | | | |
| 2 | 1-5 | 150-230 | 23-29 | 60% | 30 |
| 3 | 6-10 | 200-500 | 16-18 | 60% | 30 |
| 4 | 11-20 | 200-500 | 12-16 | 60% | 30 |
| Aggregate (Radar Types 1-4) | | | | 80% | 120 |
| <p>Note 1: Short Pulse Radar Type 0 should be used for the detection bandwidth test, channel move time, and channel closing time tests.</p> <p>Test A: 15 unique PRI values randomly selected from the list of 23 PRI values in Table 5a.</p> <p>Test B: 15 unique PRI values randomly selected within the range of 518-3066 µsec, with a minimum increment of 1 µsec, excluding PRI values selected in Test A.</p> | | | | | |

A minimum of 30 unique waveforms are required for each of the Short Pulse Radar Types 2 through 4. If more than 30 waveforms are used for Short Pulse Radar Types 2 through 4, then each additional waveform must also be unique and not repeated from the previous waveforms. If more than 30 waveforms are used for Short Pulse Radar Type 1, then each additional waveform is generated with Test B and must also be unique and not repeated from the previous waveforms in Tests A or B. Test aggregate is average of the percentage of successful detections of short pulse radar types 1-4.

TEST SETUP

Setup for Client with injection at the Master

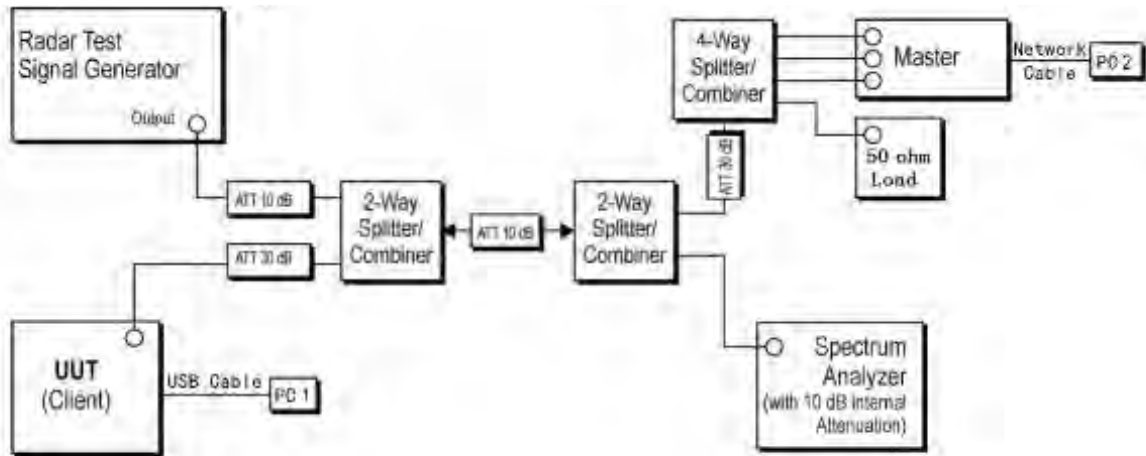

TEST ENVIRONMENT

| | | | |
|---------------------|---------|-------------------|----------|
| Temperature | 26.2 °C | Relative Humidity | 55.8 % |
| Atmosphere Pressure | 101 kPa | Test Voltage | DC 3.3 V |

RESULTS

Please refer to Appendix E & F.



12. ANTENNA REQUIREMENTS

APPLICABLE REQUIREMENTS

Please refer to FCC §15.203

An intentional radiator shall be designed to ensure that no antenna other than that furnished by the responsible party shall be used with the device. The use of a permanently attached antenna or of an antenna that uses a unique coupling to the intentional radiator shall be considered sufficient to comply with the provisions of this section. The manufacturer may design the unit so that a broken antenna can be replaced by the user, but the use of a standard antenna jack or electrical connector is prohibited.

Please refer to FCC §15.247(b)(4)

The conducted output power limit specified in paragraph (b) of this section is based on the use of antennas with directional gains that do not exceed 6 dBi. Except as shown in paragraph (c) of this section, if transmitting antennas of directional gain greater than 6 dBi are used, the conducted output power from the intentional radiator shall be reduced below the stated values in paragraphs (b)(1), (b)(2), and (b)(3) of this section, as appropriate, by the amount in dB that the directional gain of the antenna exceeds 6 dBi.

RESULTS

Complies



12.1. Appendix A1: Emission Bandwidth
12.1.1. Test Result

| Test Mode | Antenna | Channel | 26db EBW [MHz] | FL[MHz] | FH[MHz] | Limit[MHz] | Verdict | |
|-----------|--------------|--------------|----------------|----------|----------|------------|---------|------|
| 11A 20 | Ant1 | 5180 | 20.000 | 5170.000 | 5190.000 | --- | PASS | |
| | Ant2 | 5180 | 20.200 | 5169.920 | 5190.120 | --- | PASS | |
| | Ant1 | 5200 | 20.080 | 5189.800 | 5209.880 | --- | PASS | |
| | Ant2 | 5200 | 20.080 | 5189.880 | 5209.960 | --- | PASS | |
| | Ant1 | 5240 | 20.120 | 5229.920 | 5250.040 | --- | PASS | |
| | Ant2 | 5240 | 20.120 | 5229.880 | 5250.000 | --- | PASS | |
| | Ant1 | 5260 | 20.000 | 5250.080 | 5270.080 | --- | PASS | |
| | Ant2 | 5260 | 20.040 | 5250.000 | 5270.040 | --- | PASS | |
| | Ant1 | 5280 | 20.040 | 5269.960 | 5290.000 | --- | PASS | |
| | Ant2 | 5280 | 20.200 | 5269.920 | 5290.120 | --- | PASS | |
| | Ant1 | 5320 | 19.880 | 5309.960 | 5329.840 | --- | PASS | |
| | Ant2 | 5320 | 20.160 | 5309.800 | 5329.960 | --- | PASS | |
| | Ant1 | 5500 | 20.040 | 5489.920 | 5509.960 | --- | PASS | |
| | Ant2 | 5500 | 19.920 | 5489.920 | 5509.840 | --- | PASS | |
| | Ant1 | 5580 | 20.160 | 5569.880 | 5590.040 | --- | PASS | |
| | Ant2 | 5580 | 20.120 | 5569.920 | 5590.040 | --- | PASS | |
| | Ant1 | 5700 | 20.680 | 5689.600 | 5710.280 | --- | PASS | |
| | Ant2 | 5700 | 19.960 | 5690.000 | 5709.960 | --- | PASS | |
| | Ant1 | 5720 | 21.880 | 5708.520 | 5730.400 | --- | PASS | |
| | Ant2 | 5720 | 20.120 | 5709.880 | 5730.000 | --- | PASS | |
| | Ant1 | 5720_UNII-2C | 16.48 | 5708.520 | 5725 | --- | PASS | |
| | Ant2 | 5720_UNII-2C | 15.12 | 5709.880 | 5725 | --- | PASS | |
| | Ant1 | 5720_UNII-3 | 5.4 | 5725 | 5730.400 | --- | PASS | |
| | Ant2 | 5720_UNII-3 | 5 | 5725 | 5730.000 | --- | PASS | |
| | Ant1 | 5745 | 22.960 | 5733.920 | 5756.880 | --- | PASS | |
| | Ant2 | 5745 | 20.080 | 5734.920 | 5755.000 | --- | PASS | |
| | Ant1 | 5785 | 20.560 | 5774.840 | 5795.400 | --- | PASS | |
| | Ant2 | 5785 | 20.120 | 5774.880 | 5795.000 | --- | PASS | |
| | Ant1 | 5825 | 19.960 | 5815.000 | 5834.960 | --- | PASS | |
| | Ant2 | 5825 | 20.200 | 5814.920 | 5835.120 | --- | PASS | |
| | 11N20MIMO | Ant1 | 5180 | 20.360 | 5169.800 | 5190.160 | --- | PASS |
| | | Ant2 | 5180 | 20.200 | 5169.920 | 5190.120 | --- | PASS |
| Ant1 | | 5200 | 20.200 | 5189.920 | 5210.120 | --- | PASS | |
| Ant2 | | 5200 | 20.280 | 5189.840 | 5210.120 | --- | PASS | |
| Ant1 | | 5240 | 20.280 | 5229.960 | 5250.240 | --- | PASS | |
| Ant2 | | 5240 | 20.200 | 5229.920 | 5250.120 | --- | PASS | |
| Ant1 | | 5260 | 20.480 | 5249.720 | 5270.200 | --- | PASS | |
| Ant2 | | 5260 | 20.400 | 5249.760 | 5270.160 | --- | PASS | |
| Ant1 | | 5280 | 21.000 | 5269.720 | 5290.720 | --- | PASS | |
| Ant2 | | 5280 | 20.320 | 5269.960 | 5290.280 | --- | PASS | |
| Ant1 | | 5320 | 20.440 | 5309.720 | 5330.160 | --- | PASS | |
| Ant2 | | 5320 | 20.360 | 5309.920 | 5330.280 | --- | PASS | |
| Ant1 | | 5500 | 20.120 | 5490.000 | 5510.120 | --- | PASS | |
| Ant2 | | 5500 | 20.240 | 5489.920 | 5510.160 | --- | PASS | |
| Ant1 | | 5580 | 20.680 | 5569.680 | 5590.360 | --- | PASS | |
| Ant2 | | 5580 | 20.360 | 5569.800 | 5590.160 | --- | PASS | |
| Ant1 | | 5700 | 20.120 | 5689.960 | 5710.080 | --- | PASS | |
| Ant2 | | 5700 | 20.240 | 5689.840 | 5710.080 | --- | PASS | |
| Ant1 | | 5720 | 20.920 | 5709.520 | 5730.440 | --- | PASS | |
| Ant2 | | 5720 | 20.200 | 5709.880 | 5730.080 | --- | PASS | |
| Ant1 | 5720_UNII-2C | 15.48 | 5709.520 | 5725 | --- | PASS | | |



| | | | | | | | |
|------------|------|--------------|----------|----------|----------|------|------|
| | Ant2 | 5720_UNII-2C | 15.12 | 5709.880 | 5725 | --- | PASS |
| | Ant1 | 5720_UNII-3 | 5.44 | 5725 | 5730.440 | --- | PASS |
| | Ant2 | 5720_UNII-3 | 5.08 | 5725 | 5730.080 | --- | PASS |
| | Ant1 | 5745 | 20.800 | 5734.680 | 5755.480 | --- | PASS |
| | Ant2 | 5745 | 20.160 | 5734.920 | 5755.080 | --- | PASS |
| | Ant1 | 5785 | 20.440 | 5774.680 | 5795.120 | --- | PASS |
| | Ant2 | 5785 | 20.320 | 5774.800 | 5795.120 | --- | PASS |
| | Ant1 | 5825 | 20.360 | 5814.880 | 5835.240 | --- | PASS |
| | Ant2 | 5825 | 20.280 | 5814.920 | 5835.200 | --- | PASS |
| 11N40MIMO | Ant1 | 5190 | 41.520 | 5169.360 | 5210.880 | --- | PASS |
| | Ant2 | 5190 | 40.880 | 5169.520 | 5210.400 | --- | PASS |
| | Ant1 | 5230 | 41.840 | 5209.280 | 5251.120 | --- | PASS |
| | Ant2 | 5230 | 42.400 | 5209.760 | 5252.160 | --- | PASS |
| | Ant1 | 5270 | 47.200 | 5249.440 | 5296.640 | --- | PASS |
| | Ant2 | 5270 | 40.800 | 5249.600 | 5290.400 | --- | PASS |
| | Ant1 | 5310 | 41.840 | 5289.440 | 5331.280 | --- | PASS |
| | Ant2 | 5310 | 41.120 | 5289.600 | 5330.720 | --- | PASS |
| | Ant1 | 5510 | 41.360 | 5489.280 | 5530.640 | --- | PASS |
| | Ant2 | 5510 | 41.200 | 5489.520 | 5530.720 | --- | PASS |
| | Ant1 | 5550 | 41.840 | 5529.200 | 5571.040 | --- | PASS |
| | Ant2 | 5550 | 40.880 | 5529.520 | 5570.400 | --- | PASS |
| | Ant1 | 5670 | 64.400 | 5639.760 | 5704.160 | --- | PASS |
| | Ant2 | 5670 | 40.960 | 5649.600 | 5690.560 | --- | PASS |
| | Ant1 | 5710 | 41.440 | 5689.280 | 5730.720 | --- | PASS |
| | Ant2 | 5710 | 40.720 | 5689.600 | 5730.320 | --- | PASS |
| | Ant1 | 5710_UNII-2C | 35.72 | 5689.280 | 5725 | --- | PASS |
| | Ant2 | 5710_UNII-2C | 35.4 | 5689.600 | 5725 | --- | PASS |
| | Ant1 | 5710_UNII-3 | 5.72 | 5725 | 5730.720 | --- | PASS |
| | Ant2 | 5710_UNII-3 | 5.32 | 5725 | 5730.320 | --- | PASS |
| | Ant1 | 5755 | 50.720 | 5730.920 | 5781.640 | --- | PASS |
| | Ant2 | 5755 | 40.880 | 5734.520 | 5775.400 | --- | PASS |
| | Ant1 | 5795 | 41.520 | 5774.200 | 5815.720 | --- | PASS |
| | Ant2 | 5795 | 41.120 | 5774.680 | 5815.800 | --- | PASS |
| 11AC80MIMO | Ant1 | 5210 | 81.440 | 5169.200 | 5250.640 | --- | PASS |
| | Ant2 | 5210 | 81.600 | 5169.200 | 5250.800 | --- | PASS |
| | Ant1 | 5290 | 81.600 | 5249.200 | 5330.800 | --- | PASS |
| | Ant2 | 5290 | 81.280 | 5249.520 | 5330.800 | --- | PASS |
| | Ant1 | 5530 | 81.760 | 5489.200 | 5570.960 | --- | PASS |
| | Ant2 | 5530 | 81.280 | 5489.360 | 5570.640 | --- | PASS |
| | Ant1 | 5610 | 81.920 | 5569.040 | 5650.960 | --- | PASS |
| | Ant2 | 5610 | 81.280 | 5569.360 | 5650.640 | --- | PASS |
| | Ant1 | 5690 | 81.760 | 5649.040 | 5730.800 | --- | PASS |
| | Ant2 | 5690 | 81.280 | 5649.520 | 5730.800 | --- | PASS |
| | Ant1 | 5690_UNII-2C | 75.96 | 5649.040 | 5725 | --- | PASS |
| | Ant2 | 5690_UNII-2C | 75.48 | 5649.520 | 5725 | --- | PASS |
| | Ant1 | 5690_UNII-3 | 5.8 | 5725 | 5730.800 | --- | PASS |
| | Ant2 | 5690_UNII-3 | 5.8 | 5725 | 5730.800 | --- | PASS |
| | Ant1 | 5775 | 81.760 | 5734.200 | 5815.960 | --- | PASS |
| Ant2 | 5775 | 81.760 | 5734.200 | 5815.960 | --- | PASS | |

12.1.2. Test Graphs

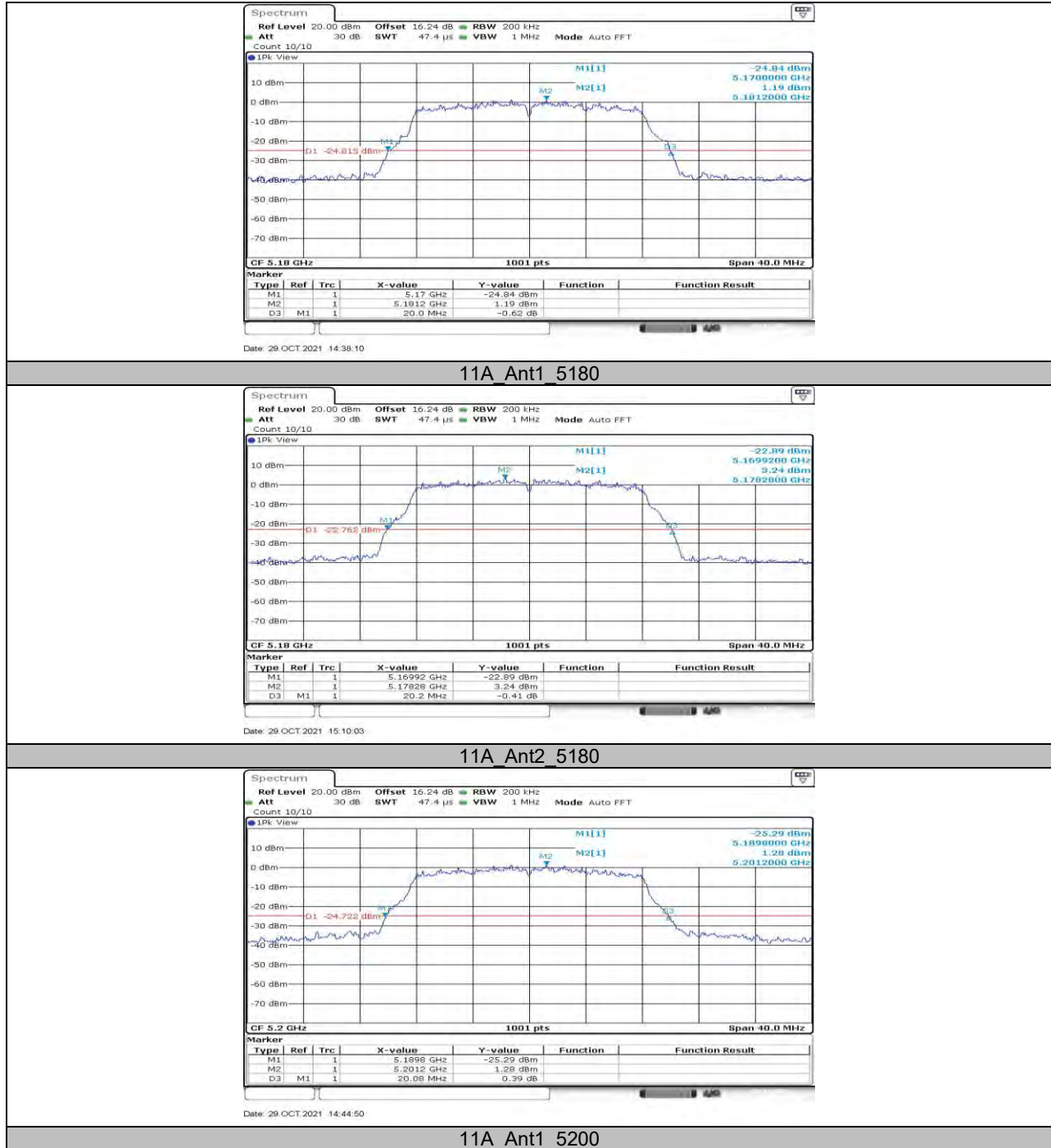

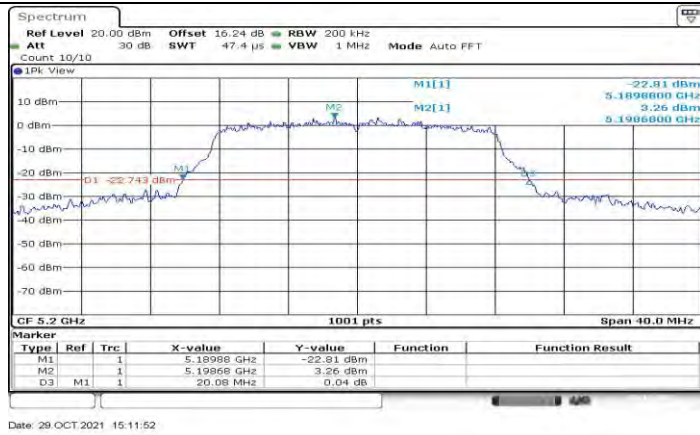

11A Ant2 5200



11A Ant1 5240

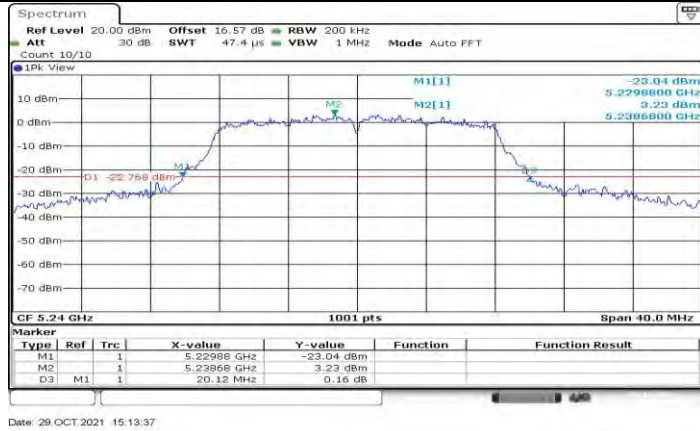

11A Ant2 5240

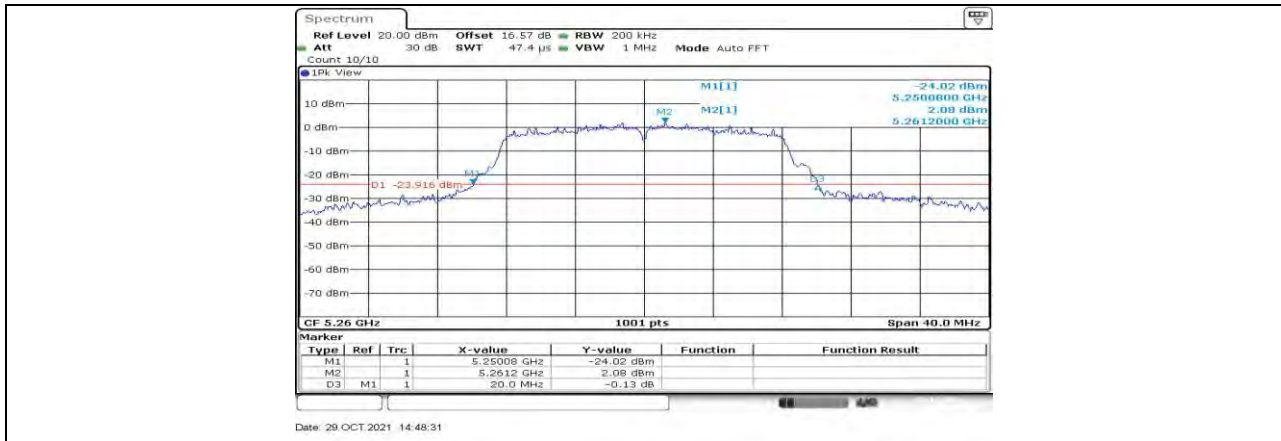

11A Ant1 5260

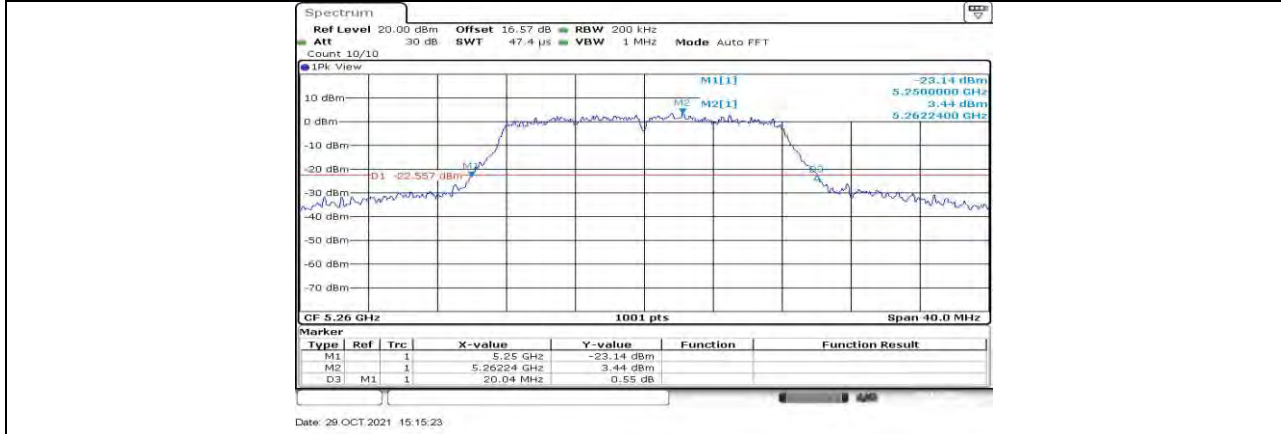

11A Ant2 5260

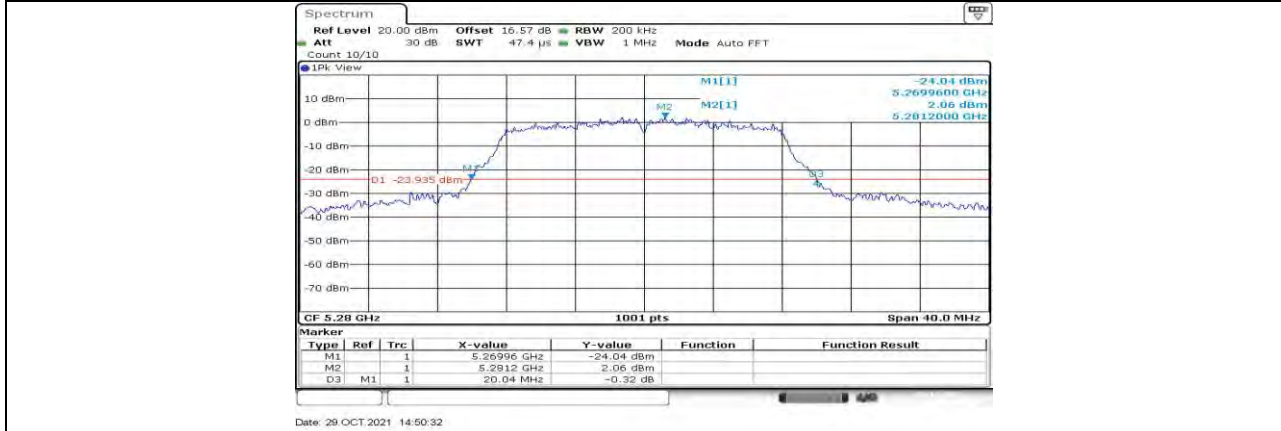

11A Ant1 5280



11A Ant2 5280

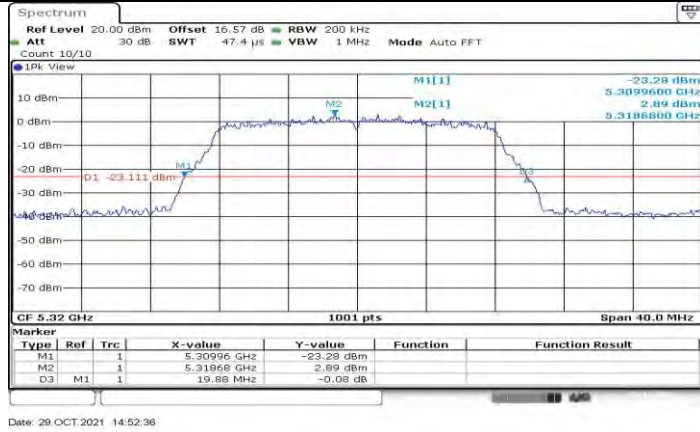

11A Ant1 5320



11A Ant2 5320

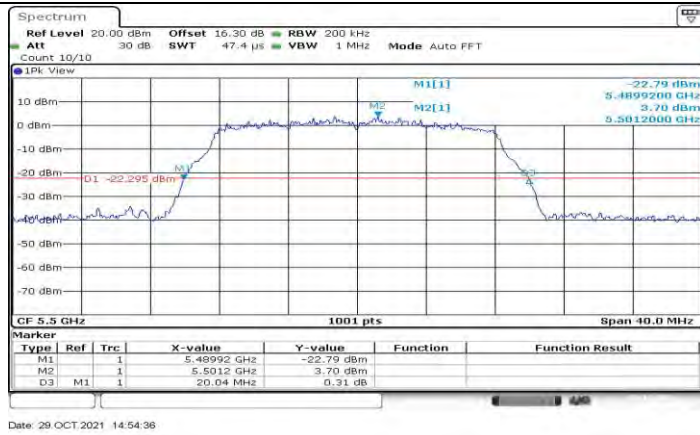

11A Ant1 5500



11A Ant2 5500

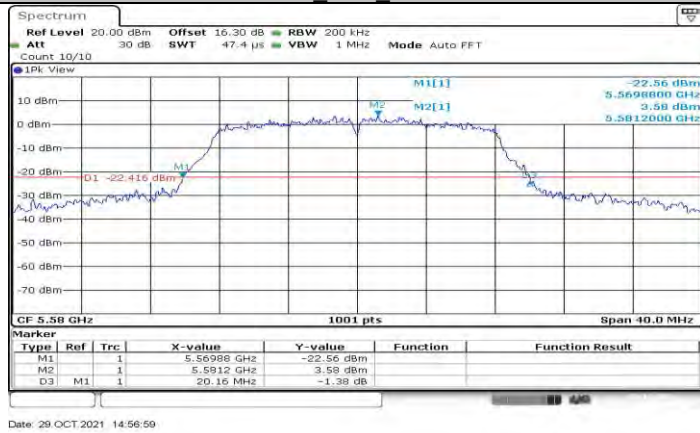

11A Ant1 5580



11A Ant2 5580

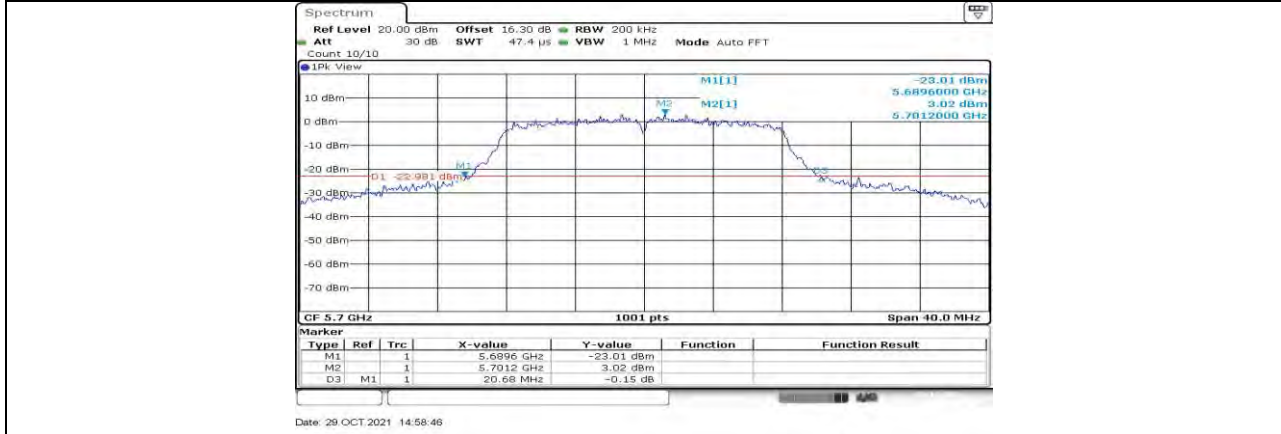

11A Ant1 5700

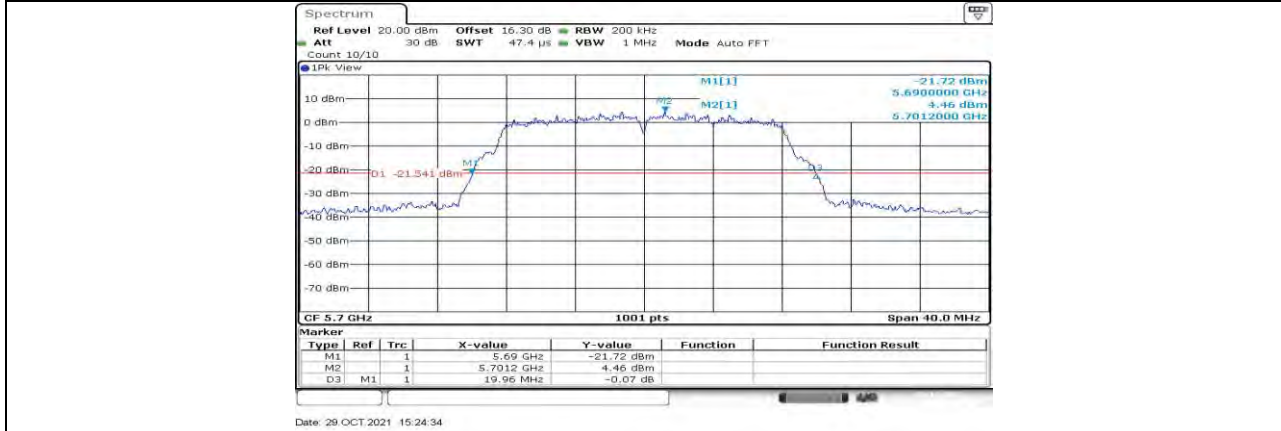

11A Ant2 5700



11A Ant1 5720



11A Ant2 5720



11A Ant1 5745

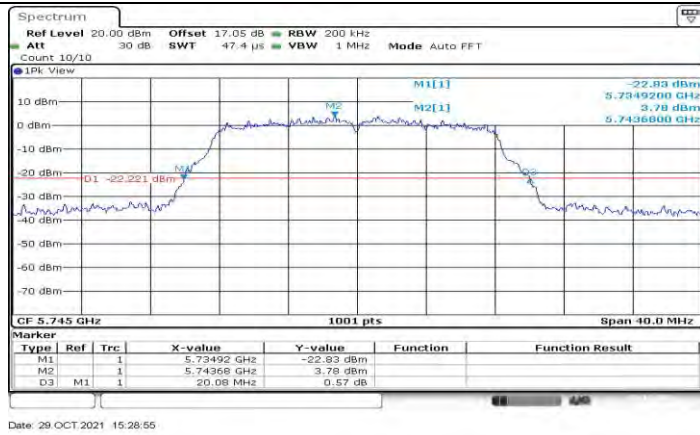

11A Ant2 5745



11A Ant1 5785

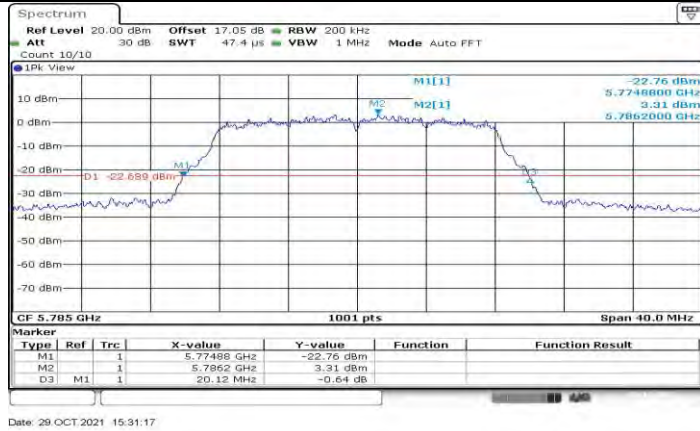

11A Ant2 5785



Date: 29 OCT 2021 15:07:46

11A Ant1 5825



Date: 29 OCT 2021 15:34:47

11A Ant2 5825

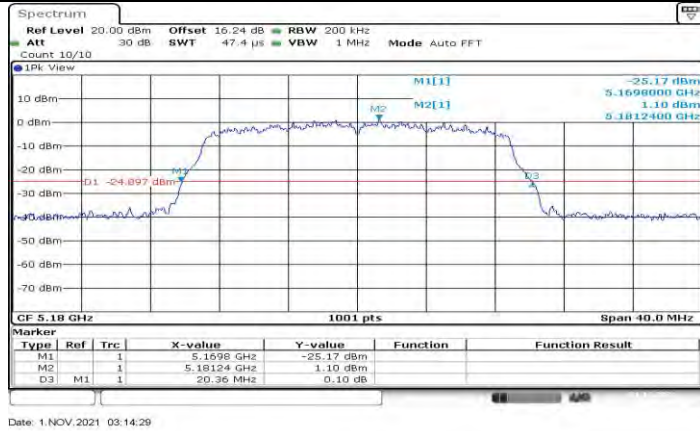

Date: 1 NOV 2021 03:14:29

11N20MIMO Ant1 5180

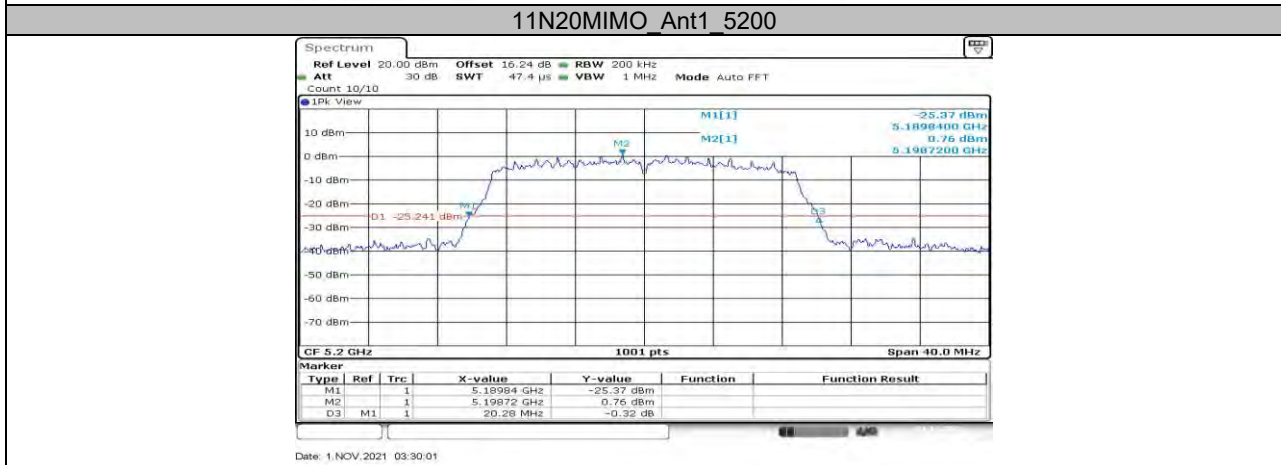
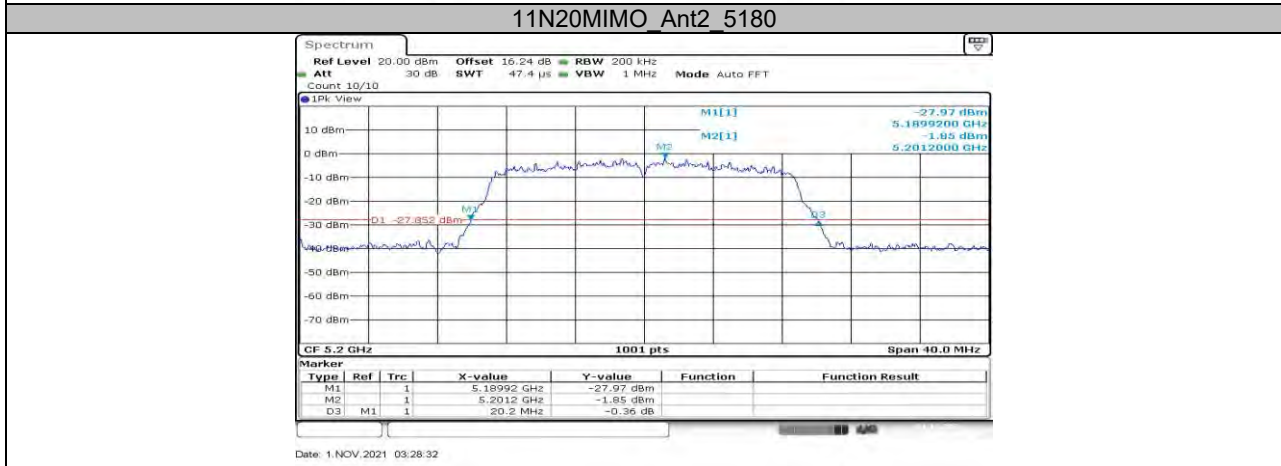
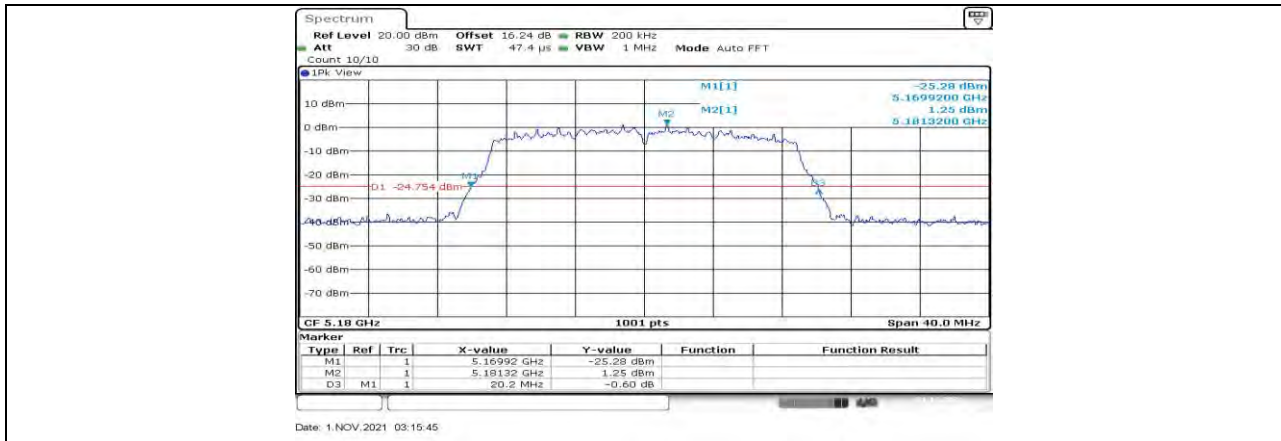

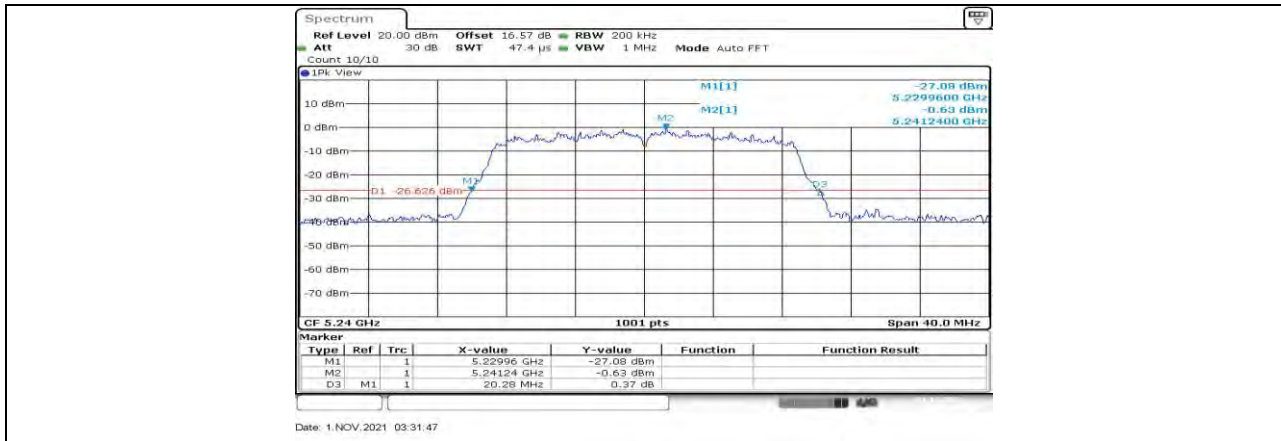

11N20MIMO Ant1 5240

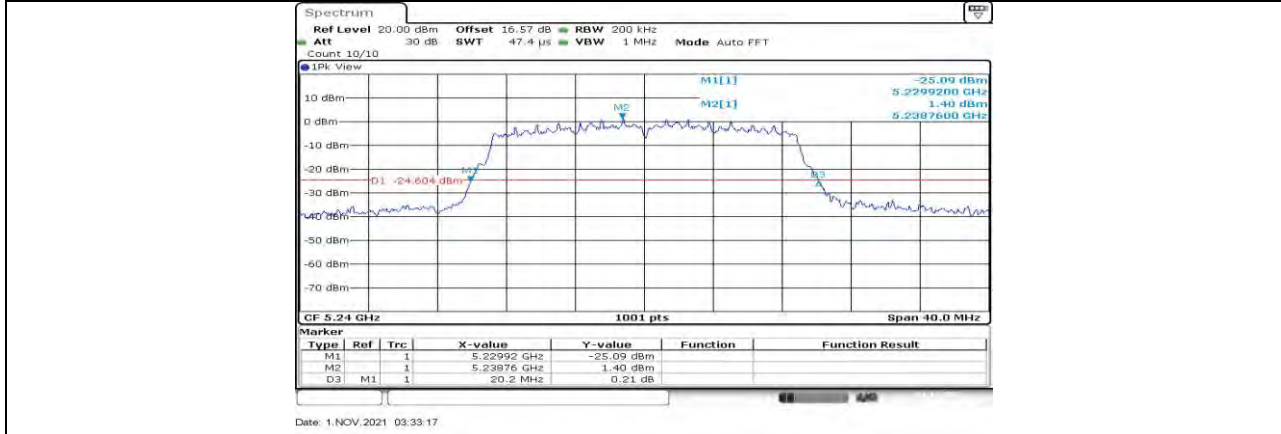

11N20MIMO Ant2 5240

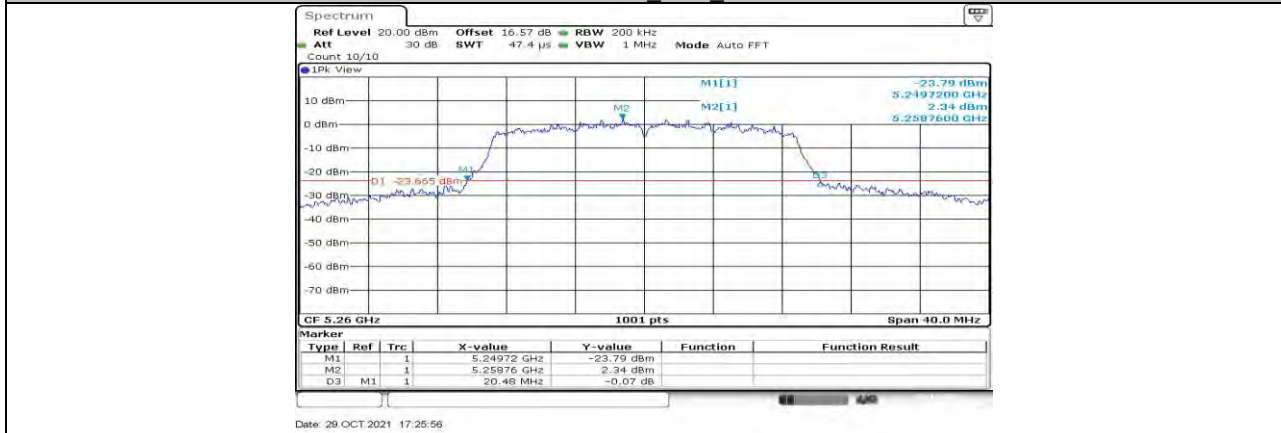

11N20MIMO Ant1 5260

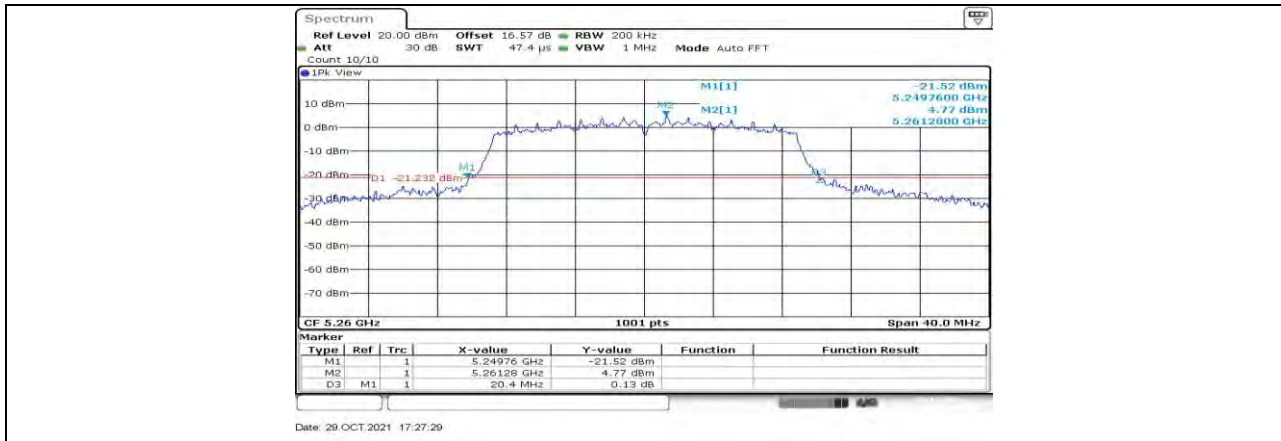

11N20MIMO Ant2 5260



11N20MIMO Ant1 5280

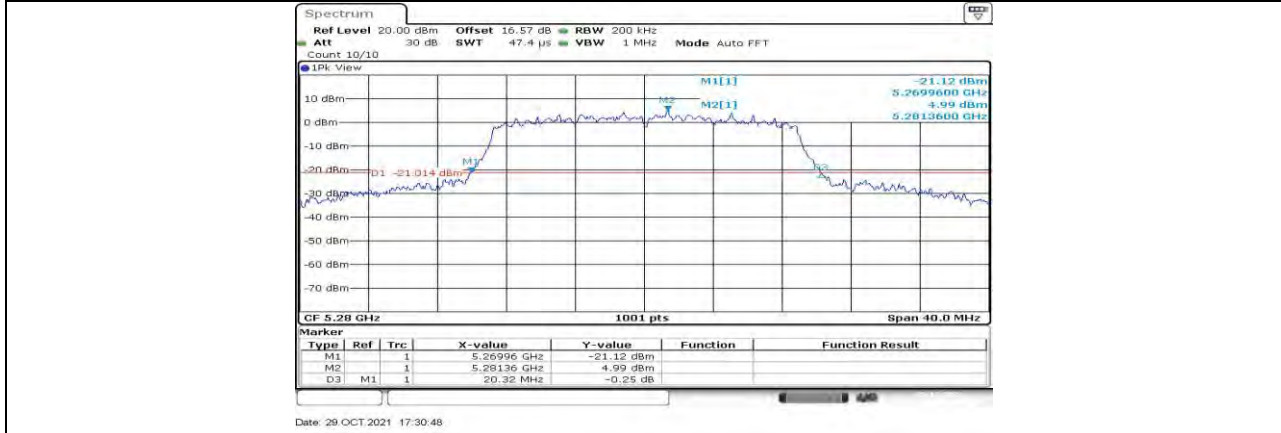

11N20MIMO Ant2 5280



11N20MIMO Ant1 5320

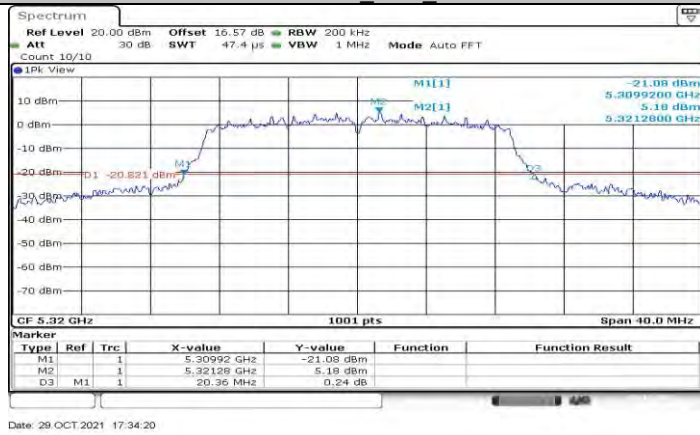

11N20MIMO Ant2 5320



11N20MIMO Ant1 5500



Date: 29 OCT 2021 17:37:41

11N20MIMO Ant2 5500

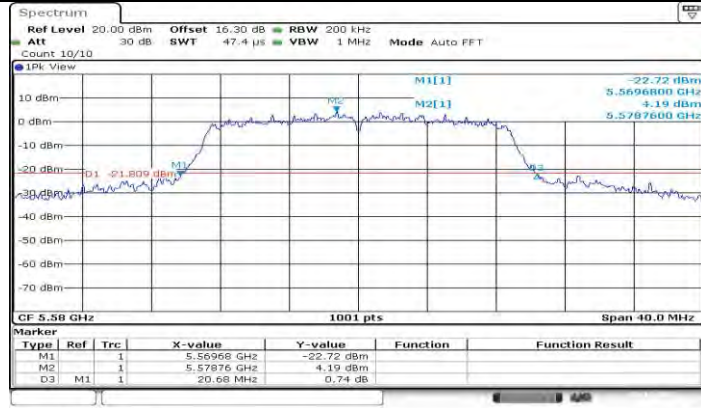

Date: 29 OCT 2021 17:39:24

11N20MIMO Ant1 5580



Date: 29 OCT 2021 17:40:54

11N20MIMO Ant2 5580

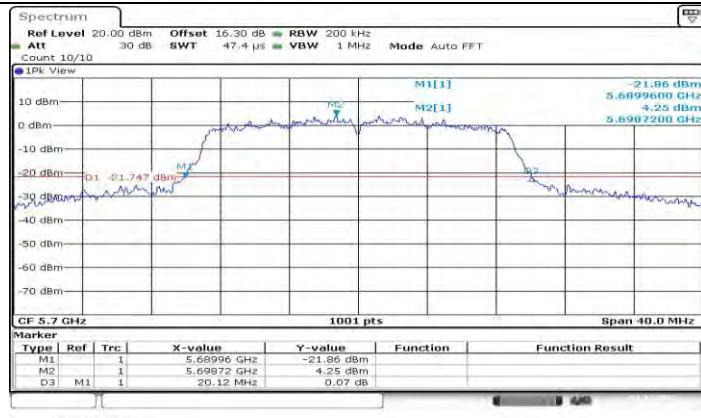

Date: 1. NOV. 2021 07:26:22

11N20MIMO Ant1 5700

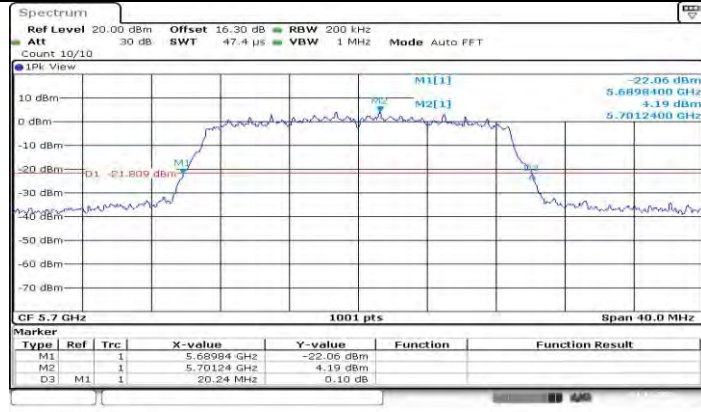

Date: 1. NOV. 2021 07:26:48

11N20MIMO Ant2 5700

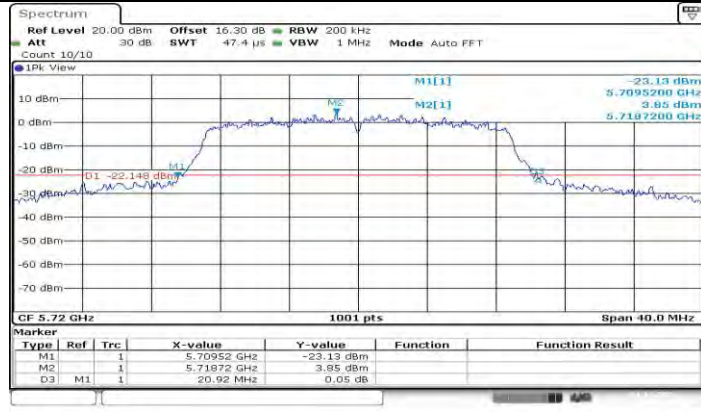

Date: 1. NOV. 2021 07:28:45

11N20MIMO Ant1 5720

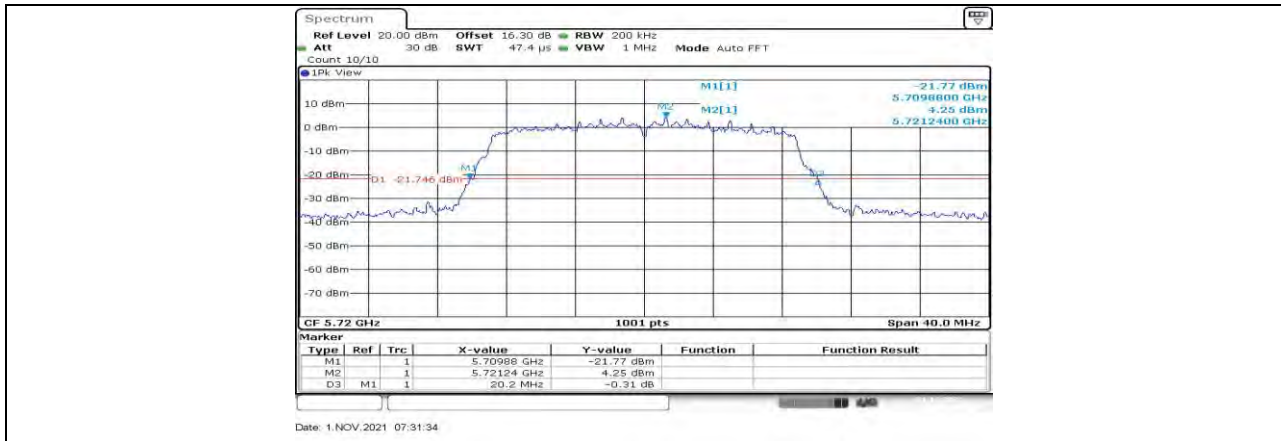

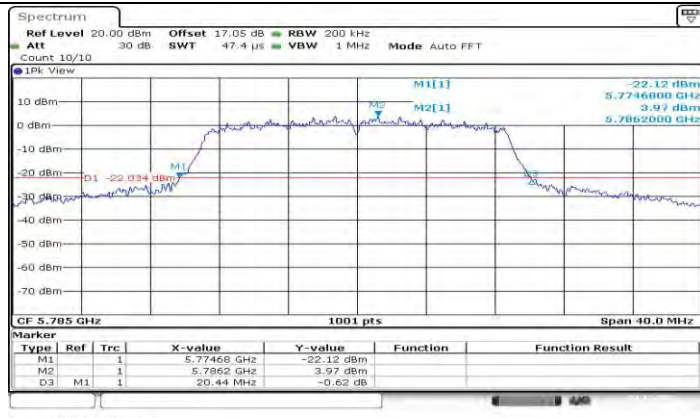

Date: 1 NOV 2021 07:38:37

11N20MIMO Ant1 5785

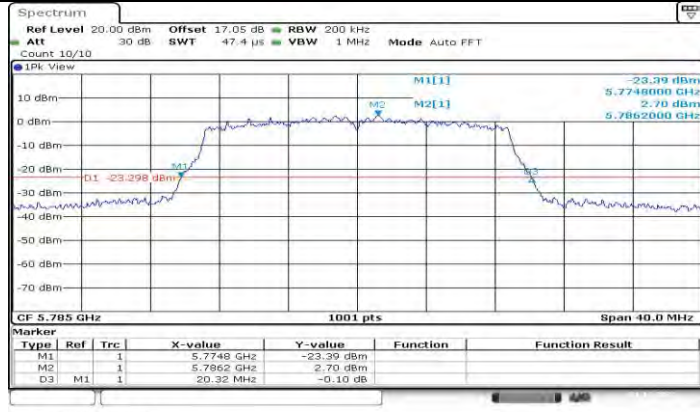

Date: 1 NOV 2021 07:39:23

11N20MIMO Ant2 5785

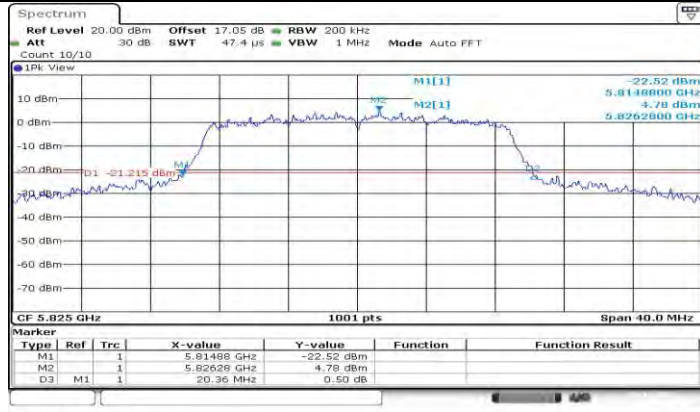

Date: 29 OCT 2021 17:58:32

11N20MIMO Ant1 5825

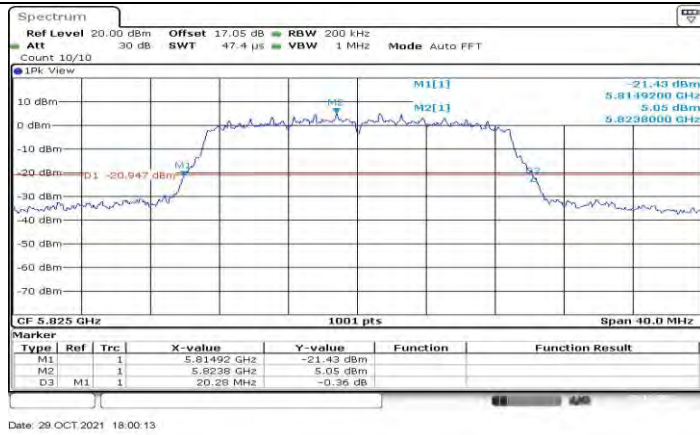

11N20MIMO Ant2 5825



11N40MIMO Ant1 5190

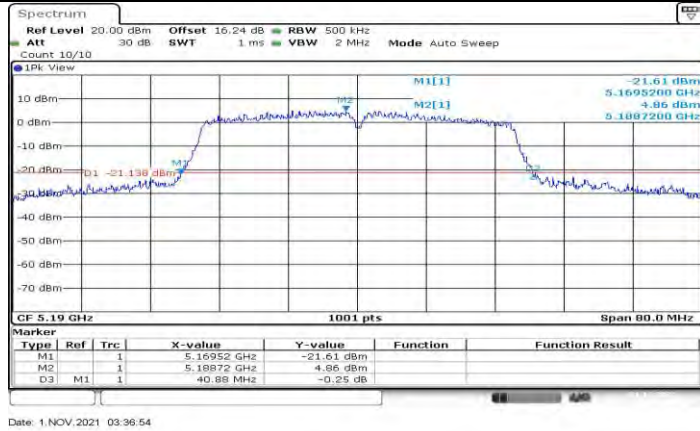

11N40MIMO Ant2 5190

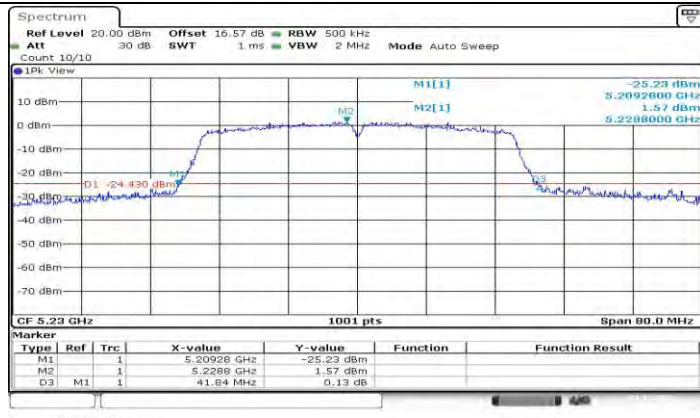

Date: 1 NOV 2021 03:38:36

11N40MIMO Ant1 5230

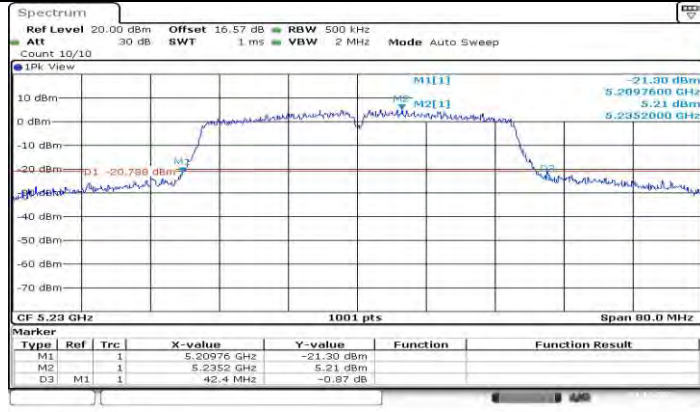

Date: 1 NOV 2021 03:40:09

11N40MIMO Ant2 5230

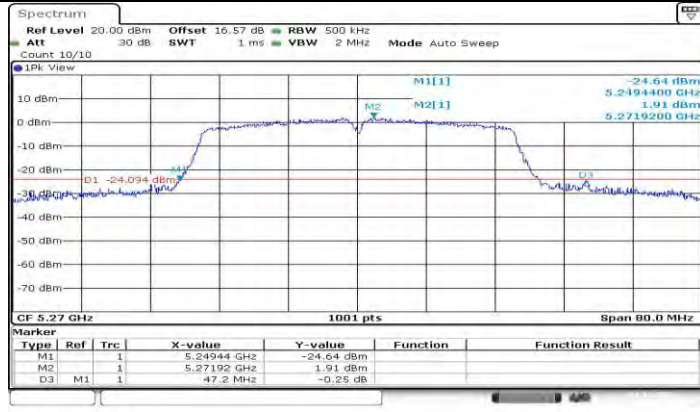

Date: 1 NOV 2021 03:41:56

11N40MIMO Ant1 5270

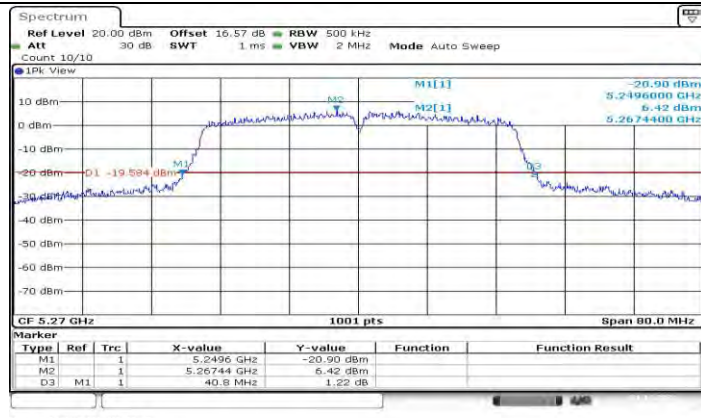

Date: 1.NOV.2021 03:43:35

11N40MIMO Ant2 5270

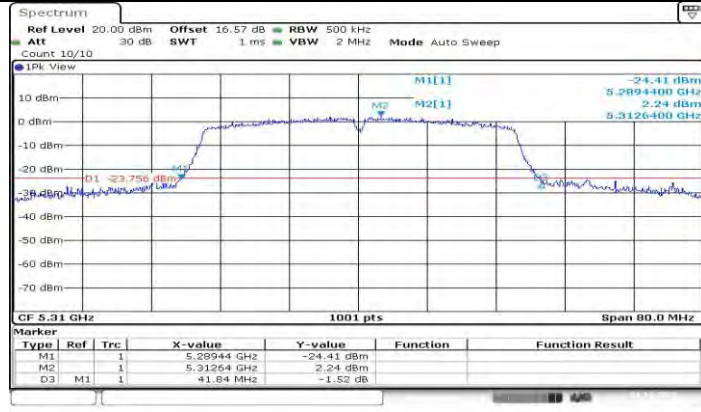

Date: 1.NOV.2021 03:50:35

11N40MIMO Ant1 5310

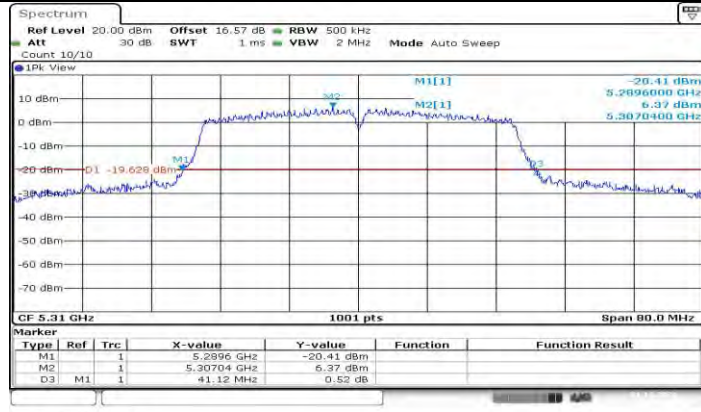

Date: 1.NOV.2021 03:52:07

11N40MIMO Ant2 5310

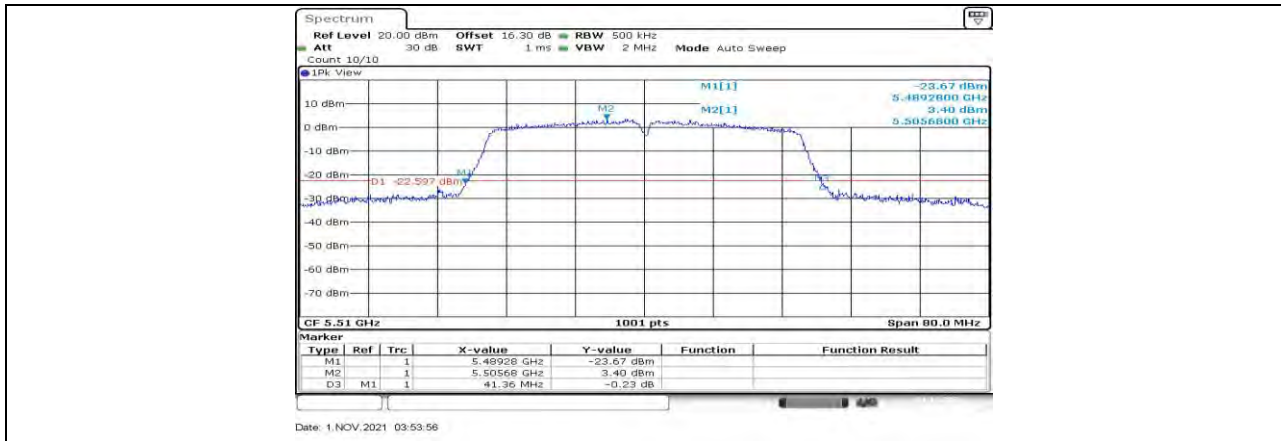

11N40MIMO Ant1 5510



11N40MIMO Ant2 5510

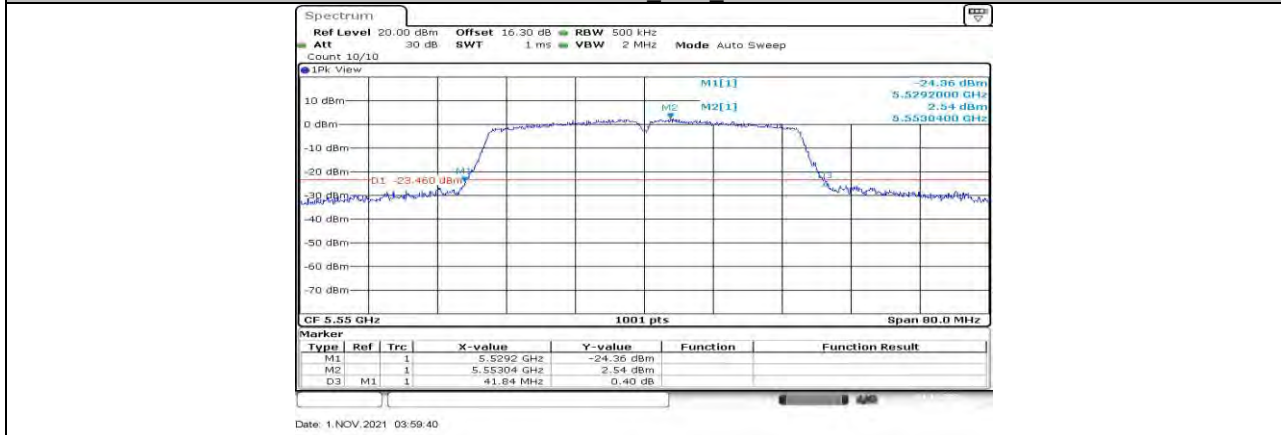

11N40MIMO Ant1 5550

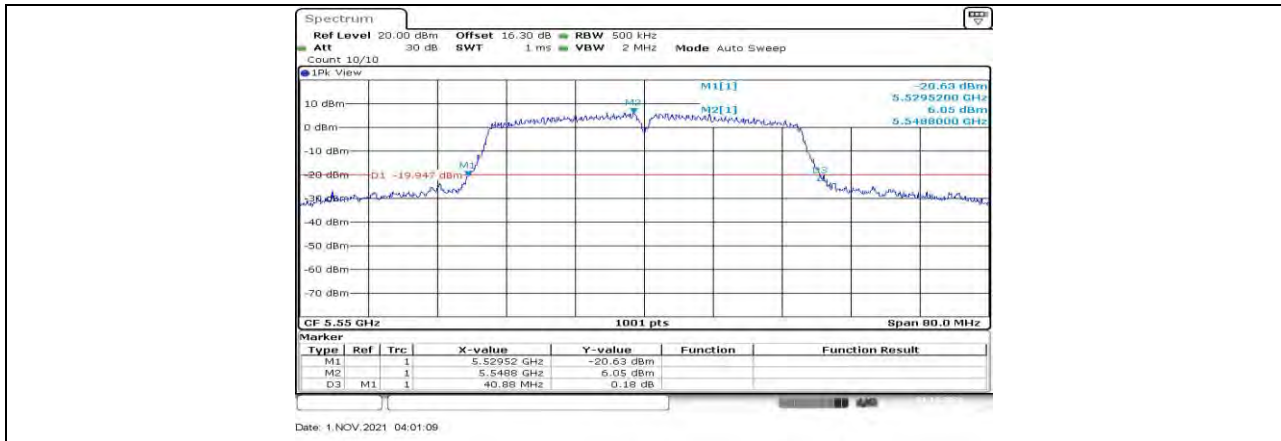

11N40MIMO Ant2 5550

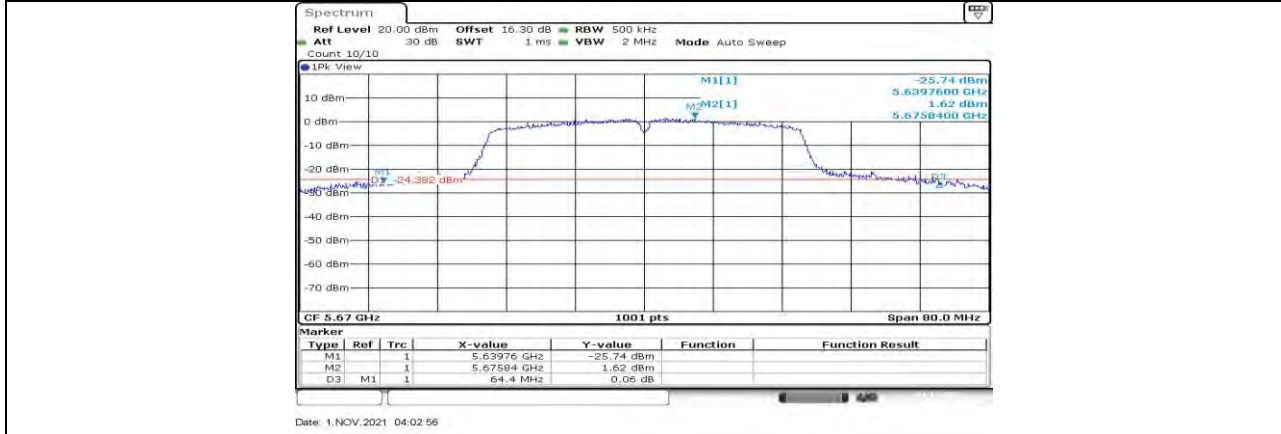

11N40MIMO Ant1 5670

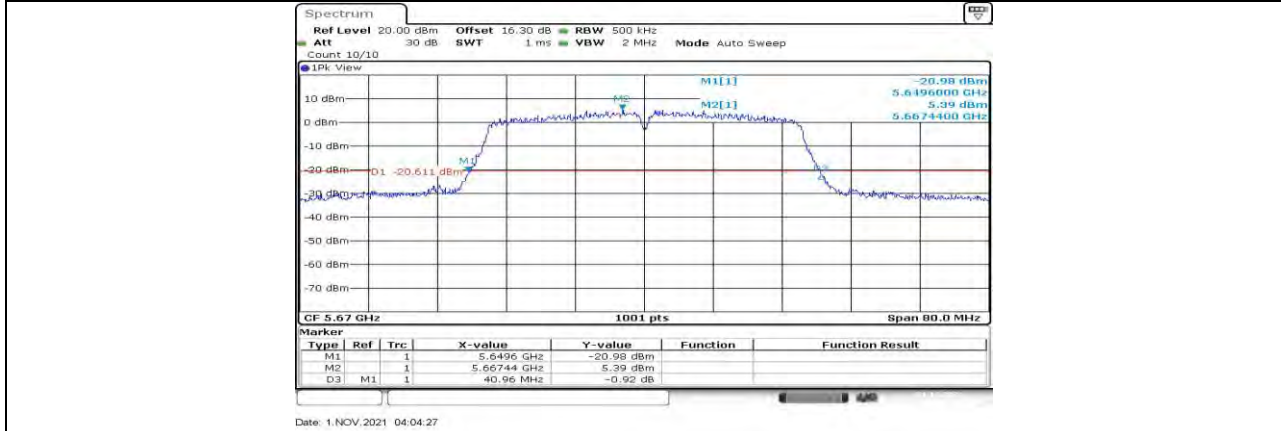

11N40MIMO Ant2 5670

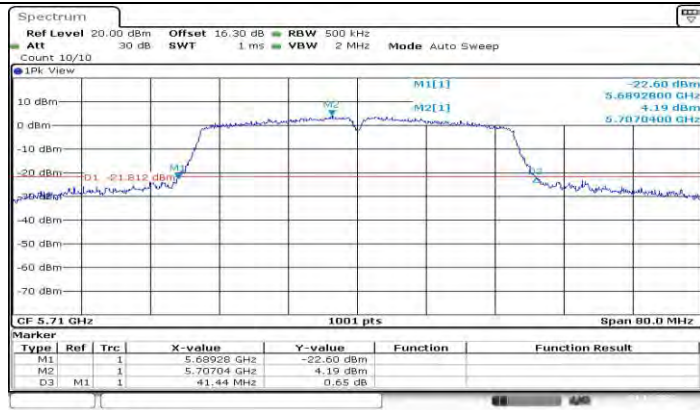

Date: 1.NOV.2021 07:18:34

11N40MIMO Ant1 5710



Date: 1.NOV.2021 07:21:23

11N40MIMO Ant2 5710

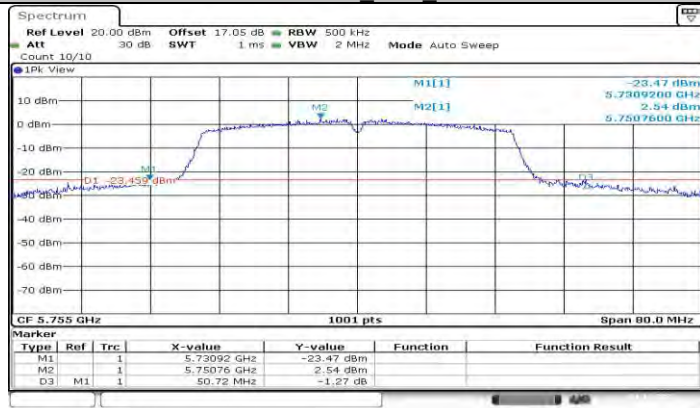

Date: 1.NOV.2021 04:13:12

11N40MIMO Ant1 5755



11N40MIMO Ant2 5755



11N40MIMO Ant1 5795

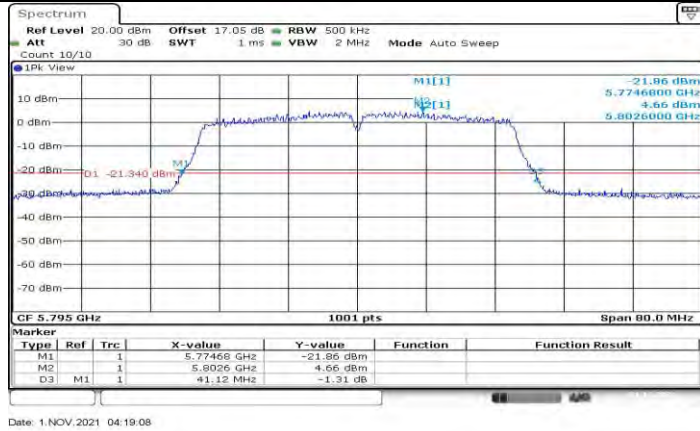

11N40MIMO Ant2 5795

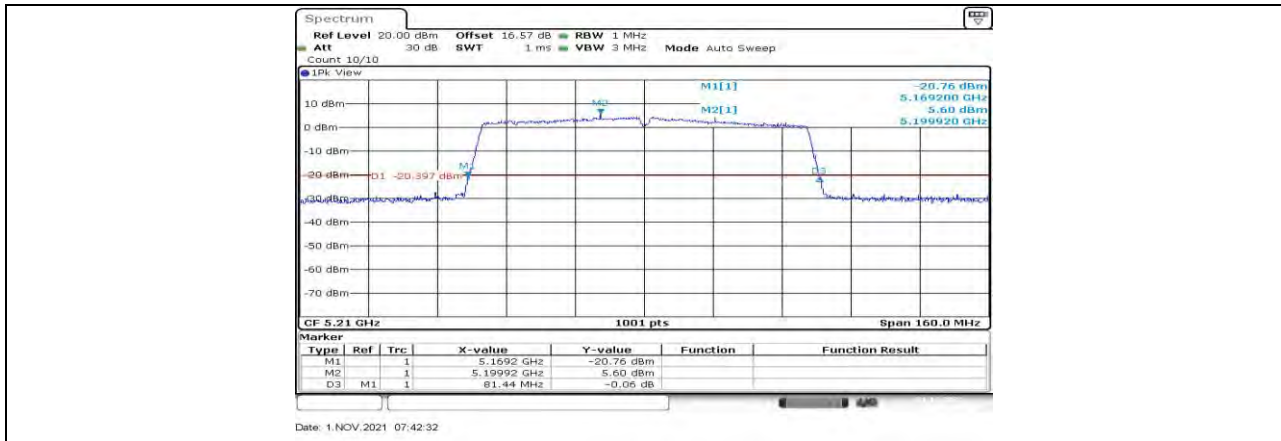

11AC80MIMO_Ant1_5210

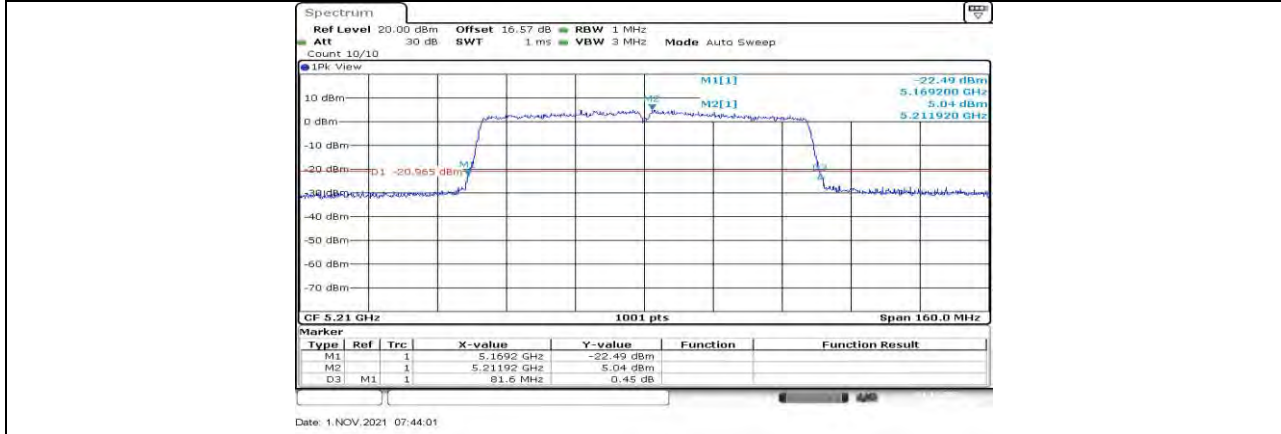

11AC80MIMO_Ant2_5210

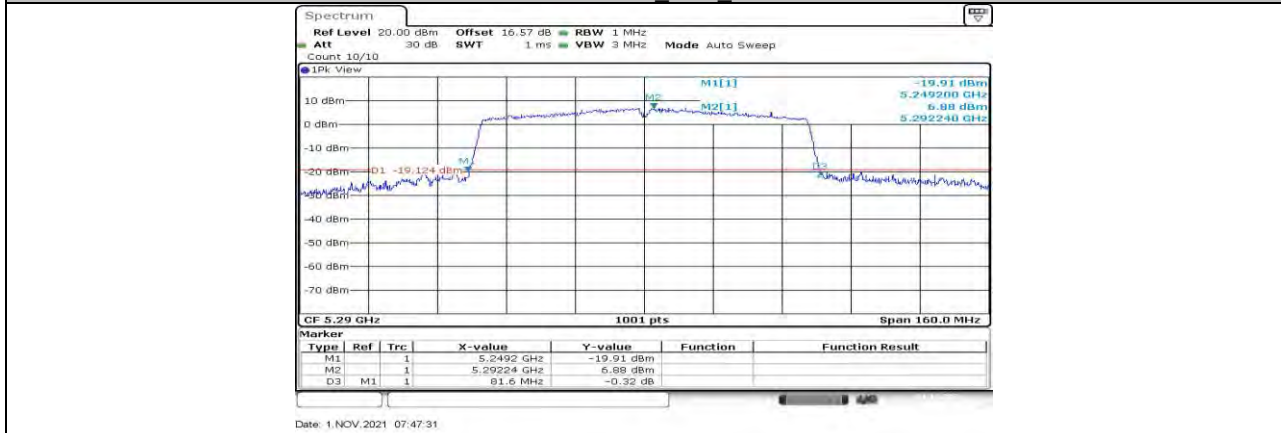

11AC80MIMO_Ant1_5290

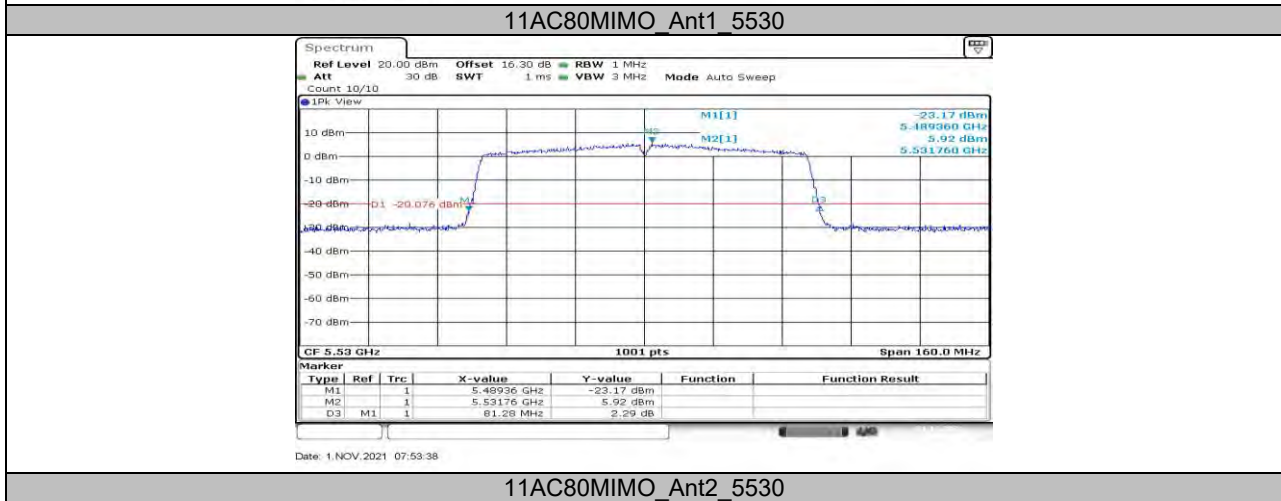
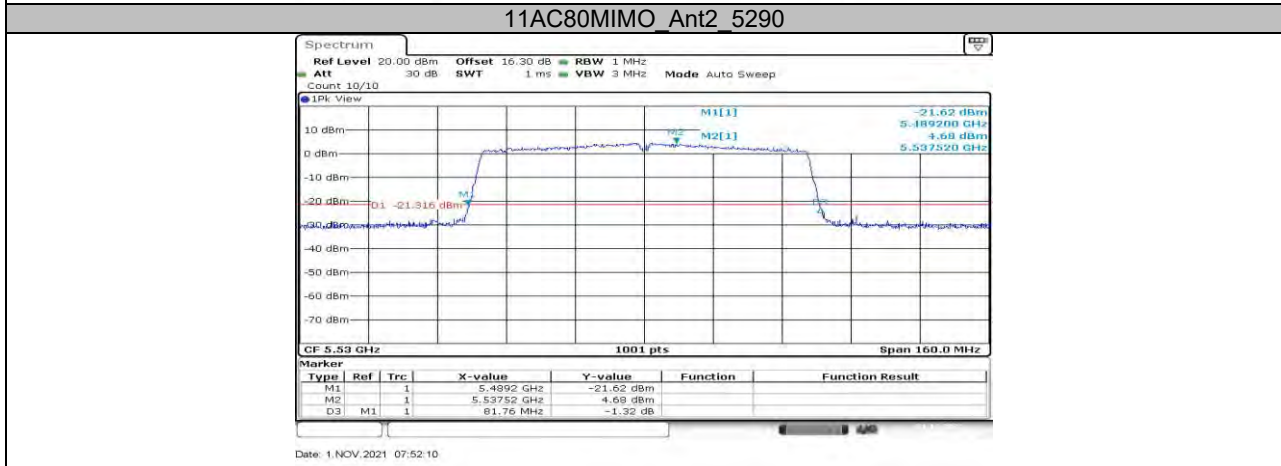
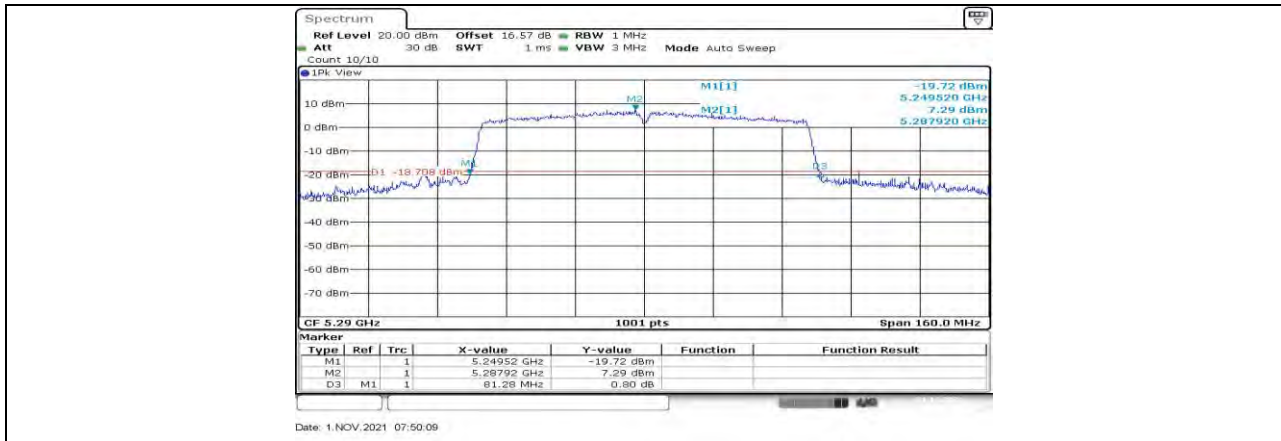

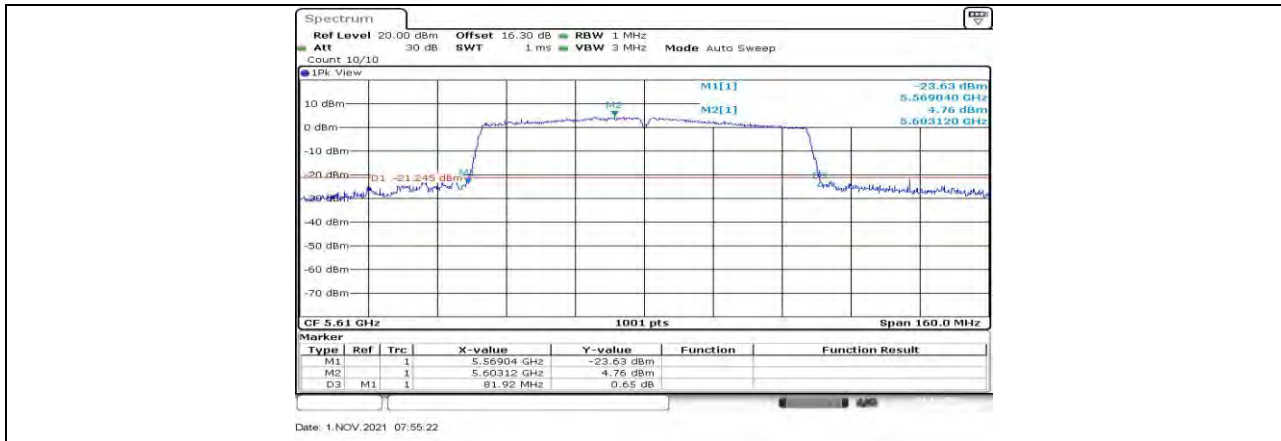

11AC80MIMO Ant1_5610

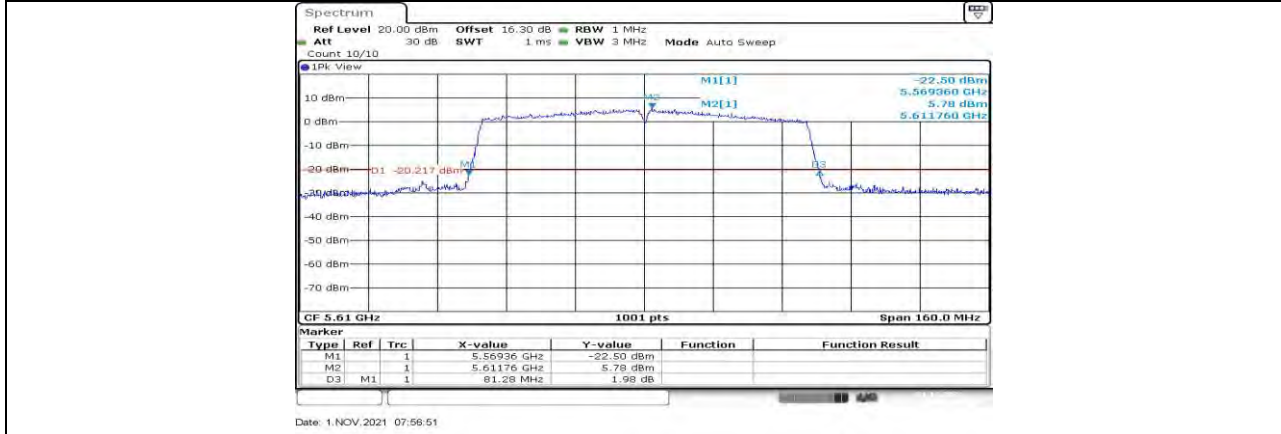

11AC80MIMO Ant2_5610

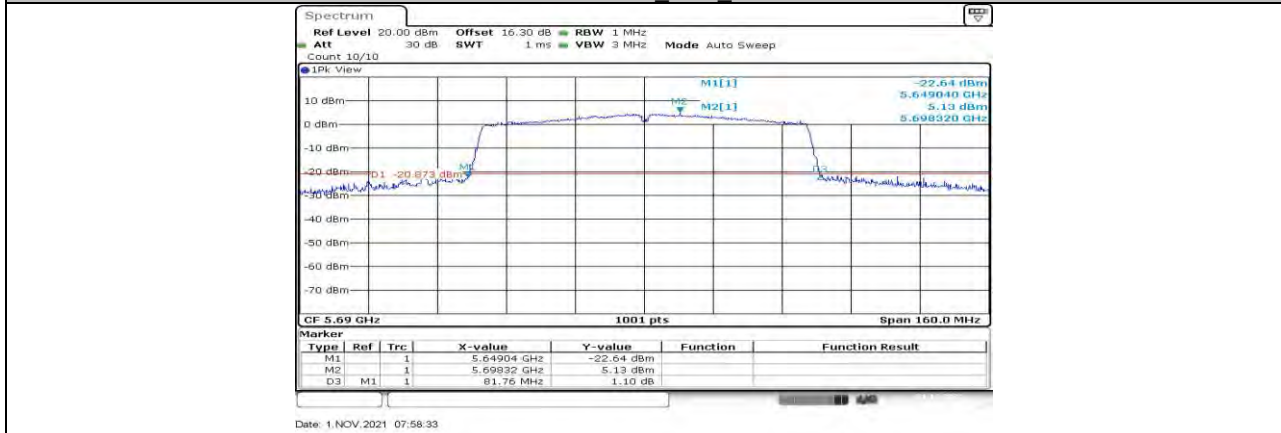

11AC80MIMO Ant1_5690

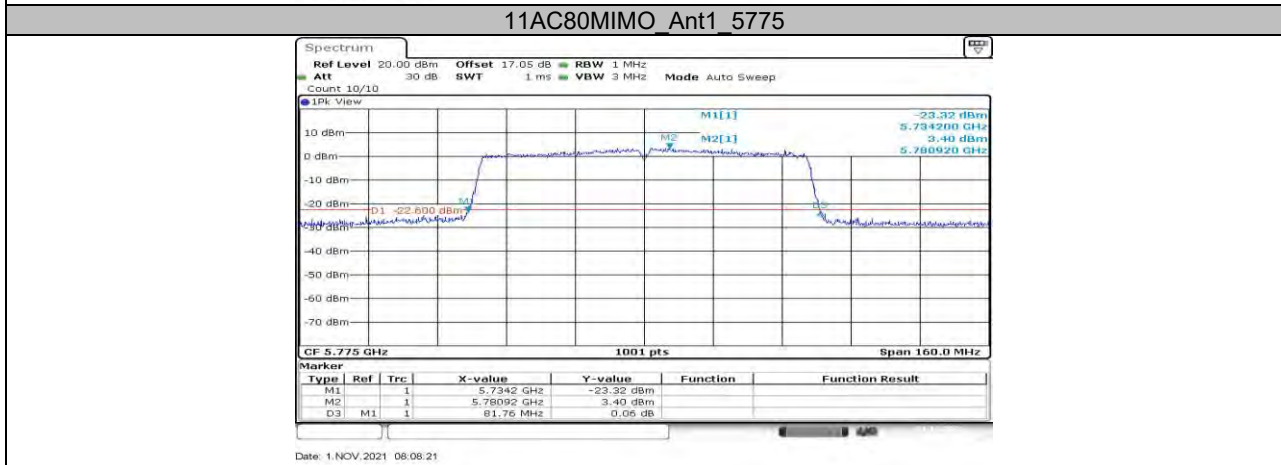
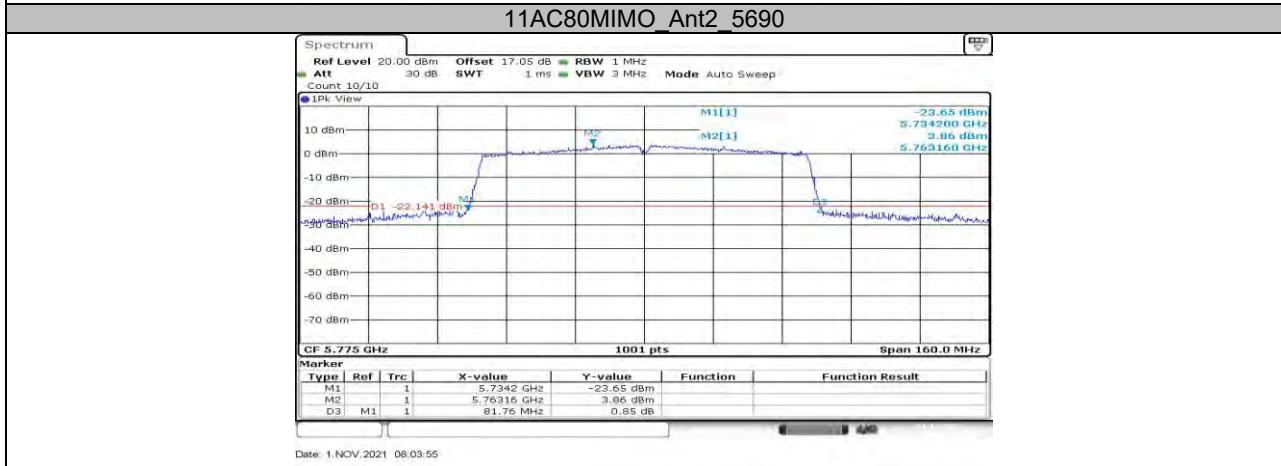
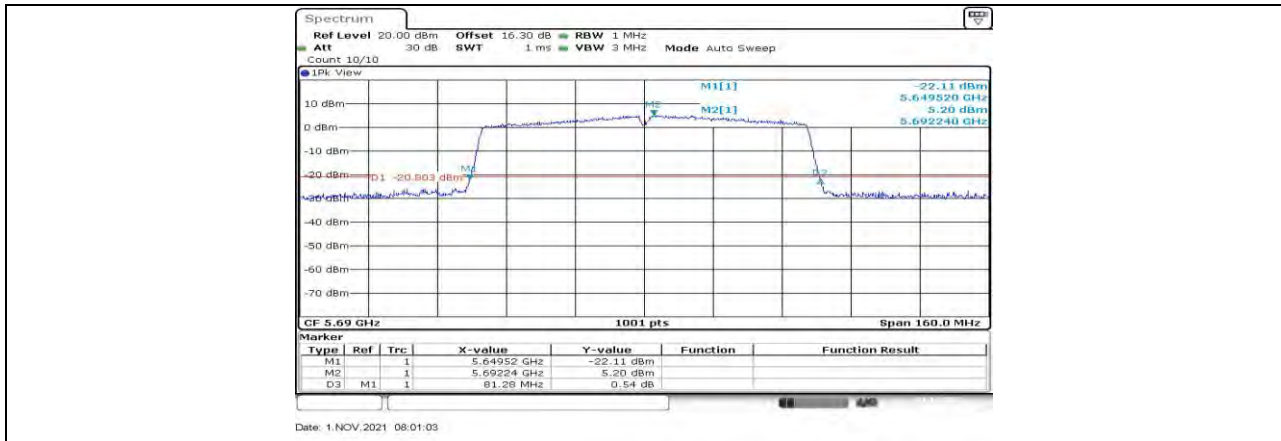

11AC80MIMO_Ant2_5775

12.2. Appendix A2: Occupied channel bandwidth
12.2.1. Test Result

| Test Mode | Antenna | Channel | OCB [MHz] | FL[MHz] | FH[MHz] | Limit[MHz] | Verdict |
|-----------|---------|--------------|-----------|----------|----------|------------|---------|
| 11A 20 | Ant1 | 5180 | 16.583 | 5171.688 | 5188.272 | --- | PASS |
| | Ant2 | 5180 | 16.663 | 5171.648 | 5188.312 | --- | PASS |
| | Ant1 | 5200 | 16.783 | 5191.568 | 5208.352 | --- | PASS |
| | Ant2 | 5200 | 16.663 | 5191.608 | 5208.272 | --- | PASS |
| | Ant1 | 5240 | 16.663 | 5231.608 | 5248.272 | --- | PASS |
| | Ant2 | 5240 | 16.783 | 5231.568 | 5248.352 | --- | PASS |
| | Ant1 | 5260 | 16.823 | 5251.568 | 5268.392 | --- | PASS |
| | Ant2 | 5260 | 16.703 | 5251.648 | 5268.352 | --- | PASS |
| | Ant1 | 5280 | 16.823 | 5271.568 | 5288.392 | --- | PASS |
| | Ant2 | 5280 | 16.583 | 5271.688 | 5288.272 | --- | PASS |
| | Ant1 | 5320 | 16.703 | 5311.608 | 5328.312 | --- | PASS |
| | Ant2 | 5320 | 16.703 | 5311.608 | 5328.312 | --- | PASS |
| | Ant1 | 5500 | 16.663 | 5491.568 | 5508.232 | --- | PASS |
| | Ant2 | 5500 | 16.823 | 5491.489 | 5508.312 | --- | PASS |
| | Ant1 | 5580 | 16.543 | 5571.688 | 5588.232 | --- | PASS |
| | Ant2 | 5580 | 16.663 | 5571.648 | 5588.312 | --- | PASS |
| | Ant1 | 5700 | 16.703 | 5691.688 | 5708.392 | --- | PASS |
| | Ant2 | 5700 | 16.743 | 5691.608 | 5708.352 | --- | PASS |
| | Ant1 | 5720 | 16.783 | 5711.608 | 5728.392 | --- | PASS |
| | Ant2 | 5720 | 16.623 | 5711.648 | 5728.272 | --- | PASS |
| | Ant1 | 5720_UNII-2C | 13.392 | 5711.608 | 5725 | --- | PASS |
| | Ant2 | 5720_UNII-2C | 13.352 | 5711.648 | 5725 | --- | PASS |
| | Ant1 | 5720_UNII-3 | 3.392 | 5725 | 5728.392 | --- | PASS |
| | Ant2 | 5720_UNII-3 | 3.272 | 5725 | 5728.272 | --- | PASS |
| | Ant1 | 5745 | 16.823 | 5736.528 | 5753.352 | --- | PASS |
| | Ant2 | 5745 | 16.623 | 5736.648 | 5753.272 | --- | PASS |
| | Ant1 | 5785 | 16.783 | 5776.528 | 5793.312 | --- | PASS |
| | Ant2 | 5785 | 16.583 | 5776.728 | 5793.312 | --- | PASS |
| | Ant1 | 5825 | 16.903 | 5816.489 | 5833.392 | --- | PASS |
| | Ant2 | 5825 | 16.464 | 5816.768 | 5833.232 | --- | PASS |
| 11N20MIMO | Ant1 | 5180 | 17.702 | 5171.169 | 5188.871 | --- | PASS |
| | Ant2 | 5180 | 17.702 | 5171.129 | 5188.831 | --- | PASS |
| | Ant1 | 5200 | 17.702 | 5191.129 | 5208.831 | --- | PASS |
| | Ant2 | 5200 | 17.622 | 5191.209 | 5208.831 | --- | PASS |
| | Ant1 | 5240 | 17.622 | 5231.249 | 5248.871 | --- | PASS |
| | Ant2 | 5240 | 17.742 | 5231.249 | 5248.991 | --- | PASS |
| | Ant1 | 5260 | 17.742 | 5251.249 | 5268.991 | --- | PASS |
| | Ant2 | 5260 | 17.782 | 5251.169 | 5268.951 | --- | PASS |
| | Ant1 | 5280 | 17.902 | 5271.209 | 5289.111 | --- | PASS |
| | Ant2 | 5280 | 17.822 | 5271.129 | 5288.951 | --- | PASS |
| | Ant1 | 5320 | 17.782 | 5311.169 | 5328.951 | --- | PASS |
| | Ant2 | 5320 | 17.742 | 5311.249 | 5328.991 | --- | PASS |
| | Ant1 | 5500 | 17.662 | 5491.209 | 5508.871 | --- | PASS |
| | Ant2 | 5500 | 17.742 | 5491.209 | 5508.951 | --- | PASS |
| | Ant1 | 5580 | 17.702 | 5571.209 | 5588.911 | --- | PASS |
| | Ant2 | 5580 | 17.662 | 5571.289 | 5588.951 | --- | PASS |
| | Ant1 | 5700 | 17.862 | 5691.009 | 5708.871 | --- | PASS |
| | Ant2 | 5700 | 17.782 | 5691.129 | 5708.911 | --- | PASS |



| | | | | | | | | |
|-----------|------------|--------------|--------|----------|----------|----------|------|------|
| | Ant1 | 5720 | 17.822 | 5711.049 | 5728.871 | --- | PASS | |
| | Ant2 | 5720 | 17.582 | 5711.209 | 5728.791 | --- | PASS | |
| | Ant1 | 5720_UNII-2C | 13.951 | 5711.049 | 5725 | --- | PASS | |
| | Ant2 | 5720_UNII-2C | 13.791 | 5711.209 | 5725 | --- | PASS | |
| | Ant1 | 5720_UNII-3 | 3.871 | 5725 | 5728.871 | --- | PASS | |
| | Ant2 | 5720_UNII-3 | 3.791 | 5725 | 5728.791 | --- | PASS | |
| | Ant1 | 5745 | 17.782 | 5736.089 | 5753.871 | --- | PASS | |
| | Ant2 | 5745 | 17.702 | 5736.089 | 5753.791 | --- | PASS | |
| | Ant1 | 5785 | 17.782 | 5776.129 | 5793.911 | --- | PASS | |
| | Ant2 | 5785 | 17.622 | 5776.169 | 5793.791 | --- | PASS | |
| 11N40MIMO | Ant1 | 5825 | 17.782 | 5816.209 | 5833.991 | --- | PASS | |
| | Ant2 | 5825 | 17.662 | 5816.289 | 5833.951 | --- | PASS | |
| | Ant1 | 5190 | 36.124 | 5171.938 | 5208.062 | --- | PASS | |
| | Ant2 | 5190 | 36.124 | 5171.938 | 5208.062 | --- | PASS | |
| | Ant1 | 5230 | 36.284 | 5211.938 | 5248.222 | --- | PASS | |
| | Ant2 | 5230 | 36.284 | 5212.018 | 5248.302 | --- | PASS | |
| | Ant1 | 5270 | 36.204 | 5252.018 | 5288.222 | --- | PASS | |
| | Ant2 | 5270 | 36.204 | 5252.018 | 5288.222 | --- | PASS | |
| | Ant1 | 5310 | 36.364 | 5291.938 | 5328.302 | --- | PASS | |
| | Ant2 | 5310 | 36.284 | 5291.938 | 5328.222 | --- | PASS | |
| | Ant1 | 5510 | 36.124 | 5492.018 | 5528.142 | --- | PASS | |
| | Ant2 | 5510 | 36.044 | 5492.098 | 5528.142 | --- | PASS | |
| | Ant1 | 5550 | 36.124 | 5531.938 | 5568.062 | --- | PASS | |
| | Ant2 | 5550 | 36.124 | 5532.018 | 5568.142 | --- | PASS | |
| | Ant1 | 5670 | 36.364 | 5651.938 | 5688.302 | --- | PASS | |
| | Ant2 | 5670 | 36.124 | 5652.018 | 5688.142 | --- | PASS | |
| | Ant1 | 5710 | 36.284 | 5691.778 | 5728.062 | --- | PASS | |
| | Ant2 | 5710 | 36.044 | 5691.938 | 5727.982 | --- | PASS | |
| | Ant1 | 5710_UNII-2C | 33.222 | 5691.778 | 5725 | --- | PASS | |
| | Ant2 | 5710_UNII-2C | 33.062 | 5691.938 | 5725 | --- | PASS | |
| | Ant1 | 5710_UNII-3 | 3.062 | 5725 | 5728.062 | --- | PASS | |
| | Ant2 | 5710_UNII-3 | 2.982 | 5725 | 5727.982 | --- | PASS | |
| | Ant1 | 5755 | 36.284 | 5736.938 | 5773.222 | --- | PASS | |
| | Ant2 | 5755 | 36.204 | 5736.858 | 5773.062 | --- | PASS | |
| | Ant1 | 5795 | 36.124 | 5777.018 | 5813.142 | --- | PASS | |
| | Ant2 | 5795 | 36.204 | 5776.938 | 5813.142 | --- | PASS | |
| | 11AC80MIMO | Ant1 | 5210 | 75.924 | 5171.958 | 5247.882 | --- | PASS |
| | | Ant2 | 5210 | 75.924 | 5172.118 | 5248.042 | --- | PASS |
| Ant1 | | 5290 | 75.764 | 5252.278 | 5328.042 | --- | PASS | |
| Ant2 | | 5290 | 75.445 | 5252.278 | 5327.722 | --- | PASS | |
| Ant1 | | 5530 | 75.604 | 5492.278 | 5567.882 | --- | PASS | |
| Ant2 | | 5530 | 75.445 | 5492.278 | 5567.722 | --- | PASS | |
| Ant1 | | 5610 | 75.764 | 5571.958 | 5647.722 | --- | PASS | |
| Ant2 | | 5610 | 75.924 | 5571.958 | 5647.882 | --- | PASS | |
| Ant1 | | 5690 | 75.604 | 5652.278 | 5727.882 | --- | PASS | |
| Ant2 | | 5690 | 75.445 | 5652.438 | 5727.882 | --- | PASS | |
| Ant1 | | 5690_UNII-2C | 72.722 | 5652.278 | 5725 | --- | PASS | |
| Ant2 | | 5690_UNII-2C | 72.562 | 5652.438 | 5725 | --- | PASS | |
| Ant1 | | 5690_UNII-3 | 2.882 | 5725 | 5727.882 | --- | PASS | |
| Ant2 | | 5690_UNII- | 2.882 | 5725 | 5727.882 | --- | PASS | |



| | | | | | | | |
|--|------|------|--------|----------|----------|-----|------|
| | | 3 | | | | | |
| | Ant1 | 5775 | 76.084 | 5737.118 | 5813.202 | --- | PASS |
| | Ant2 | 5775 | 76.084 | 5737.118 | 5813.202 | --- | PASS |

12.2.2. Test Graphs

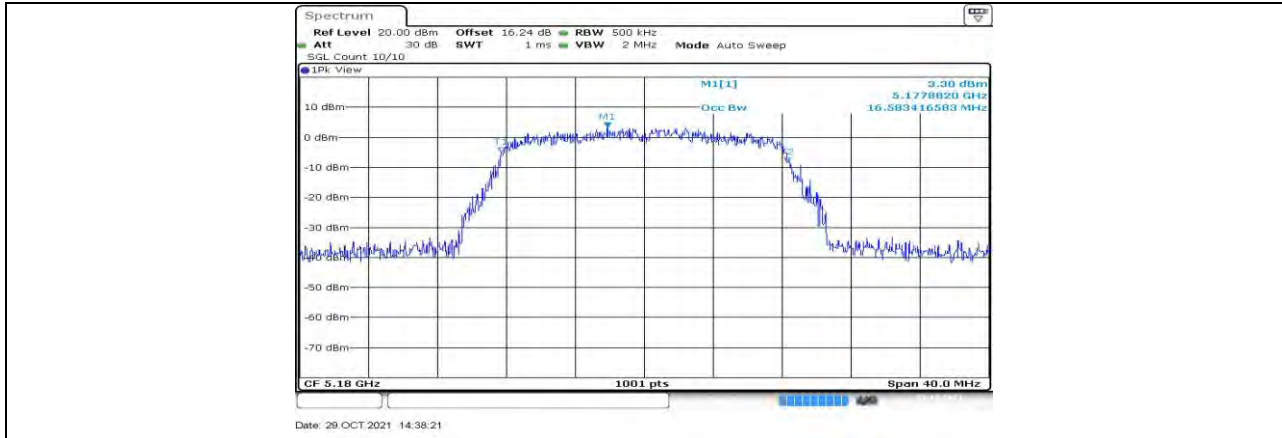

11A_Ant1_5180



11A_Ant2_5180

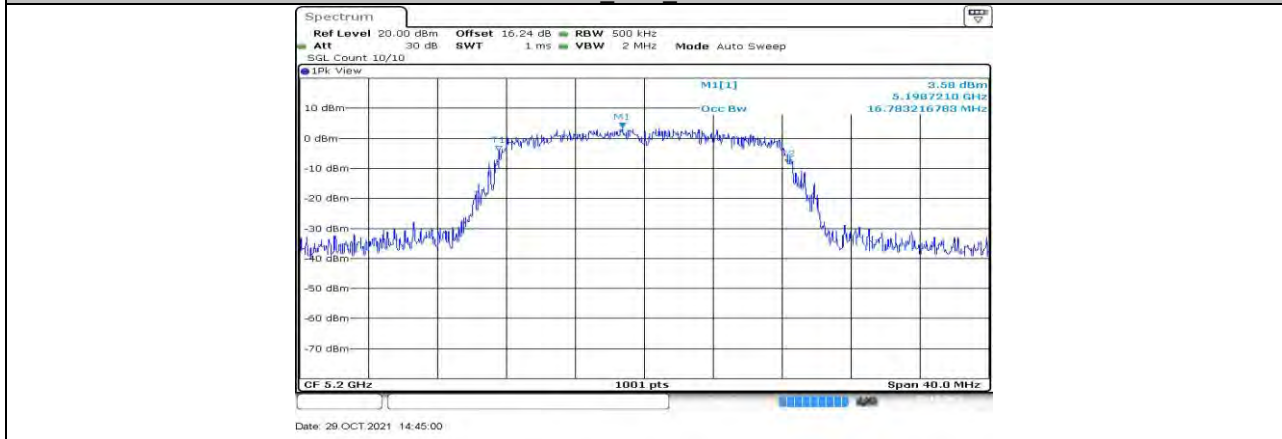

11A_Ant1_5200

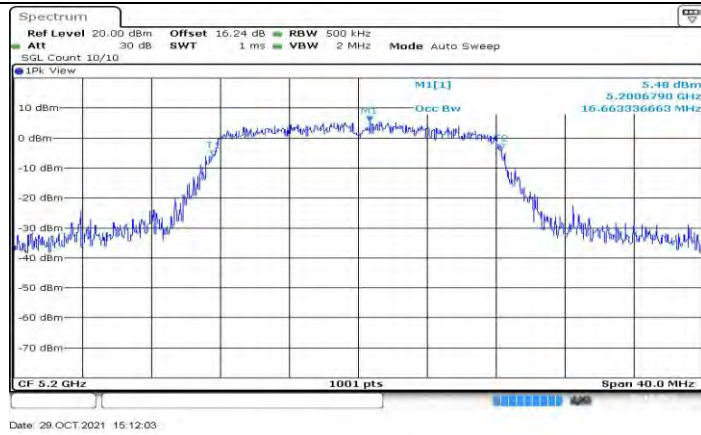

11A Ant2 5200

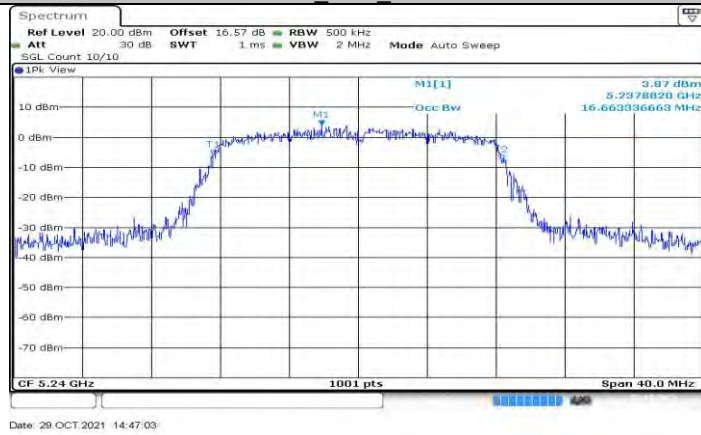

11A Ant1 5240

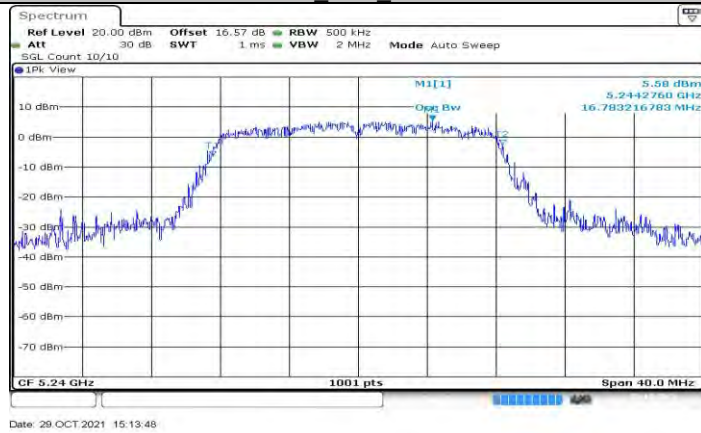

11A Ant2 5240

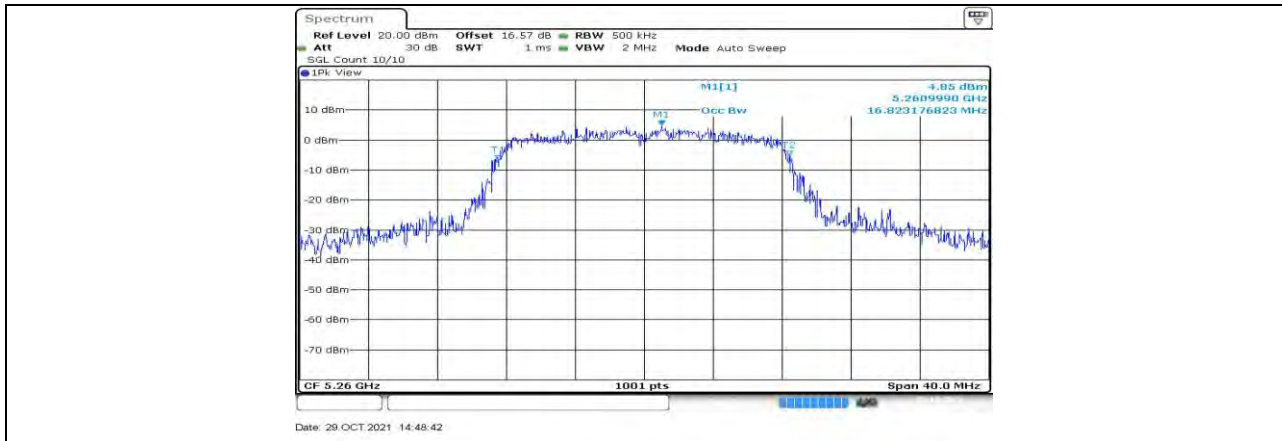

11A Ant1 5260



11A Ant2 5260



11A Ant1 5280

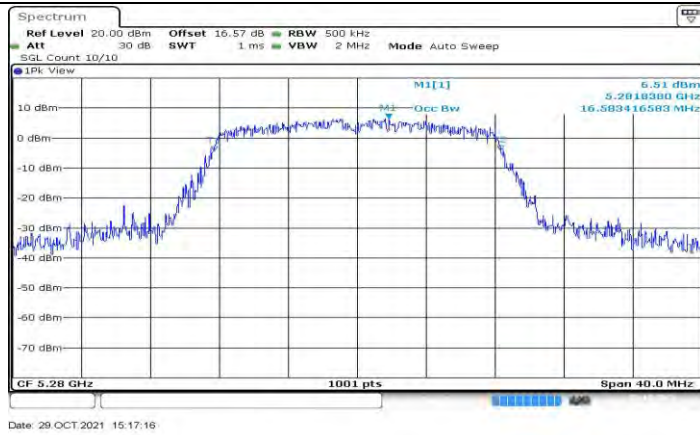

11A_Ant2_5280



11A_Ant1_5320



11A_Ant2_5320

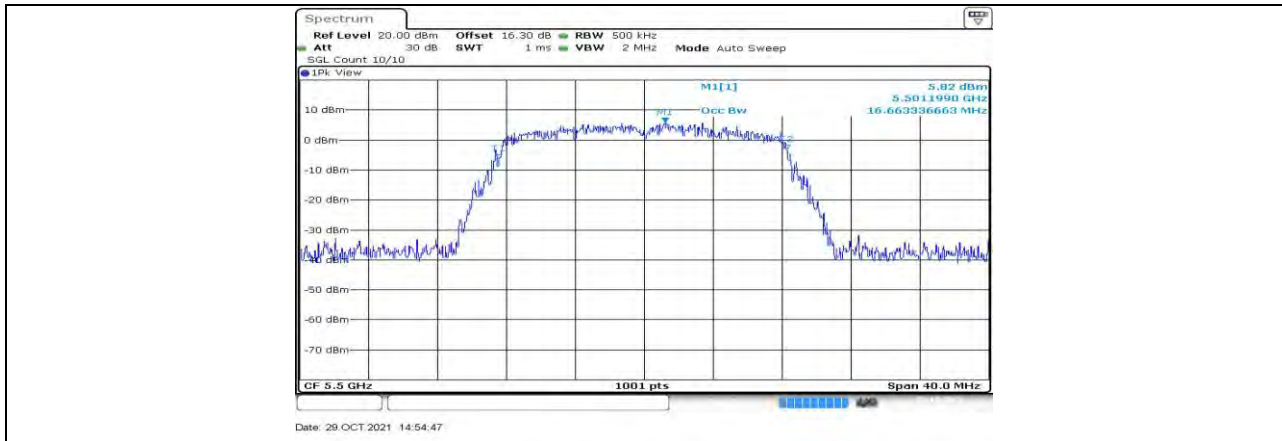

11A Ant1 5500



11A Ant2 5500

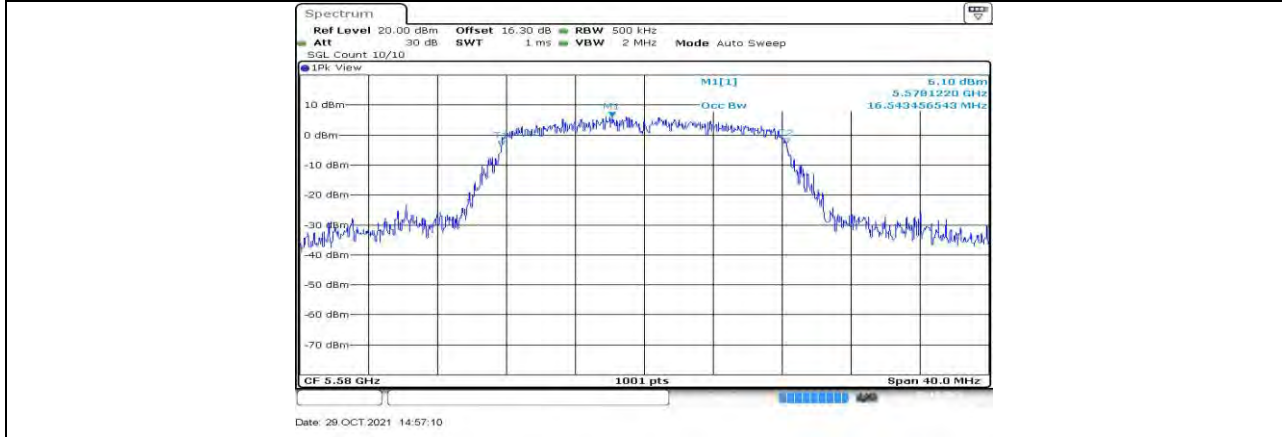

11A Ant1 5580