



## Appendix B. Plots of SAR Measurement

### P01 802.11b\_Rear Face\_0cm\_Ch6\_Ant A\_ACON

**DUT: 512732-02\_ACON**

Communication System: WLAN\_2.4G; Frequency: 2437 MHz; Duty Cycle: 1:1  
Medium: B2450\_150720 Medium parameters used:  $f = 2437$  MHz;  $\sigma = 1.985$  S/m;  $\epsilon_r = 51.34$ ;  $\rho = 1000$  kg/m<sup>3</sup>

**Ambient Temperature : 23.2 °C; Liquid Temperature : 22.6 °C**

DASY5 Configuration:

- Probe: EX3DV4 - SN3976; ConvF(7.26, 7.26, 7.26); Calibrated: 2015/2/26;
- Sensor-Surface: 2mm (Mechanical Surface Detection)
- Electronics: DAE4 Sn1424; Calibrated: 2015/2/20
- Phantom: ELI v5.0; Type: QDOVA002AA; Serial: TP:1238
- Measurement SW: DASY52, Version 52.8 (8); SEMCAD X Version 14.6.10 (7331)

**Ch6/Area Scan (201x271x1):** Interpolated grid: dx=1.200 mm, dy=1.200 mm

Maximum value of SAR (interpolated) = 0.443 W/kg

**Ch6/Zoom Scan (5x5x7)/Cube 0:** Measurement grid: dx=8mm, dy=8mm, dz=5mm

Reference Value = 15.35 V/m; Power Drift = -0.01 dB

Peak SAR (extrapolated) = 0.622 W/kg

**SAR(1 g) = 0.295 W/kg; SAR(10 g) = 0.142 W/kg**

Maximum value of SAR (measured) = 0.445 W/kg

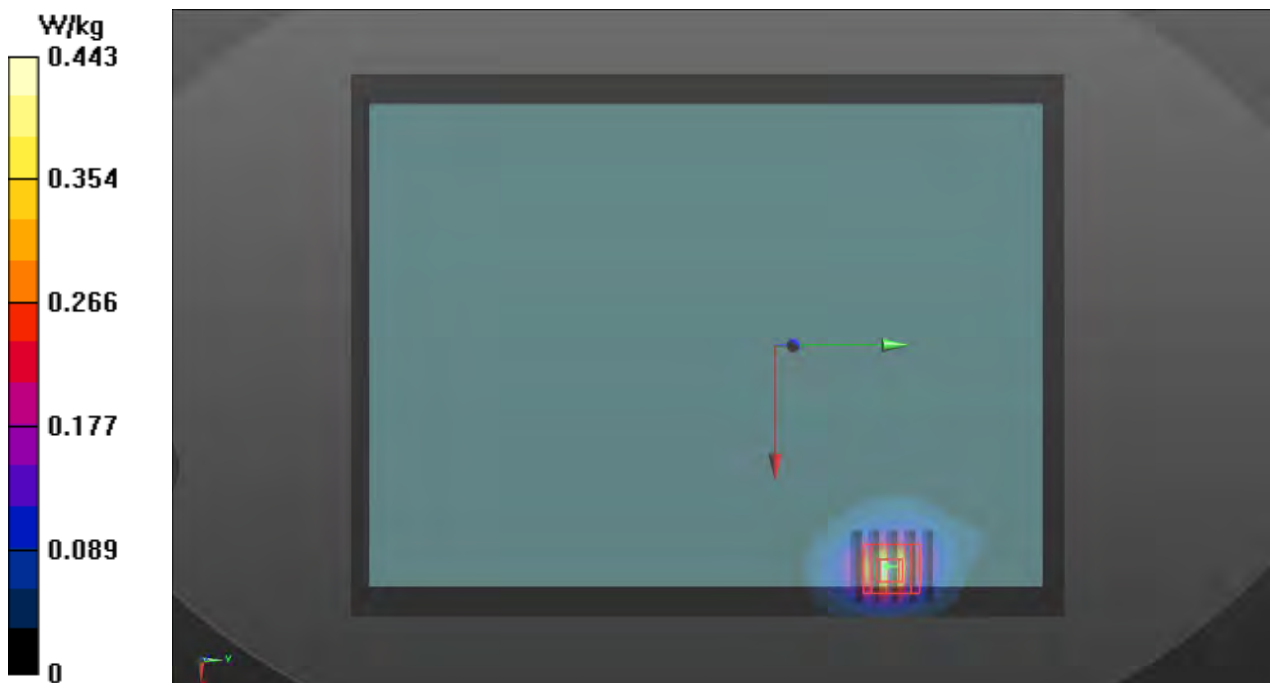

## P02 802.11b\_Edge 3\_0cm\_Ch6\_Ant A\_ACON

**DUT: 512732-02\_ACON**

Communication System: WLAN\_2.4G; Frequency: 2437 MHz; Duty Cycle: 1:1  
Medium: B2450\_150720 Medium parameters used:  $f = 2437$  MHz;  $\sigma = 1.985$  S/m;  $\epsilon_r = 51.34$ ;  $\rho = 1000$  kg/m<sup>3</sup>

**Ambient Temperature : 23.2 °C; Liquid Temperature : 22.6 °C**

DASY5 Configuration:

- Probe: EX3DV4 - SN3976; ConvF(7.26, 7.26, 7.26); Calibrated: 2015/2/26;
- Sensor-Surface: 2mm (Mechanical Surface Detection)
- Electronics: DAE4 Sn1424; Calibrated: 2015/2/20
- Phantom: ELI v5.0; Type: QDOVA002AA; Serial: TP:1238
- Measurement SW: DASY52, Version 52.8 (8); SEMCAD X Version 14.6.10 (7331)

**Ch6/Area Scan (31x271x1):** Interpolated grid: dx=1.200 mm, dy=1.200 mm

Maximum value of SAR (interpolated) = 0.850 W/kg

**Ch6/Zoom Scan (5x5x7)/Cube 0:** Measurement grid: dx=8mm, dy=8mm, dz=5mm

Reference Value = 20.79 V/m; Power Drift = -0.01 dB

Peak SAR (extrapolated) = 1.24 W/kg

**SAR(1 g) = 0.553 W/kg; SAR(10 g) = 0.247 W/kg**

Maximum value of SAR (measured) = 0.844 W/kg

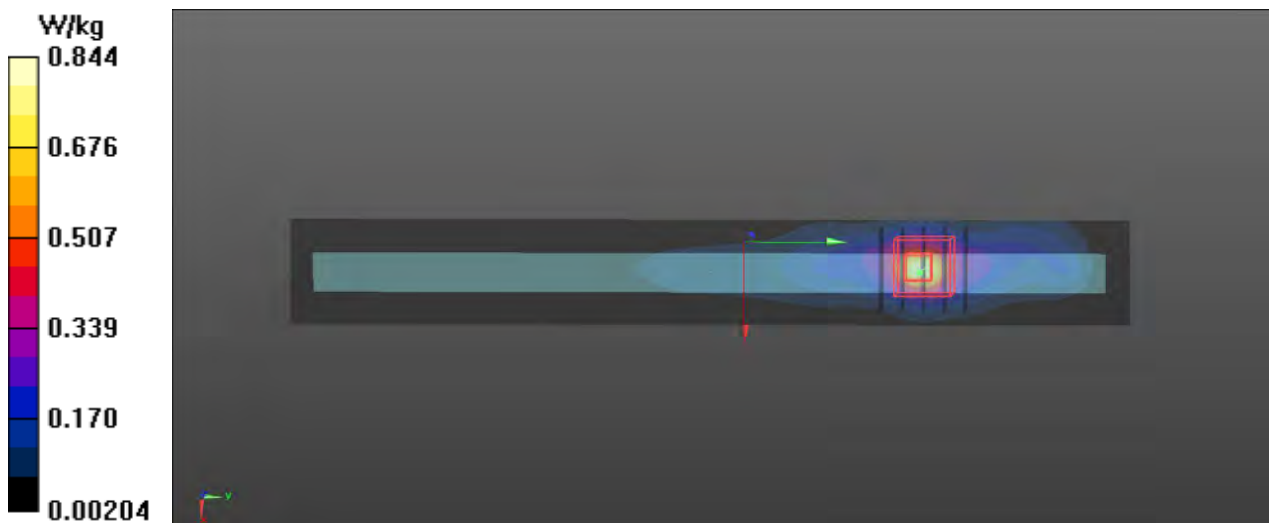

### P03 802.11b\_Rear Face\_0cm\_Ch6\_Ant A\_Inpaq

**DUT: 512732-02\_Inpaq**

Communication System: WLAN\_2.4G; Frequency: 2437 MHz; Duty Cycle: 1:1  
Medium: B2450\_150718 Medium parameters used:  $f = 2437$  MHz;  $\sigma = 1.988$  S/m;  $\epsilon_r = 51.322$ ;  $\rho = 1000$  kg/m<sup>3</sup>

**Ambient Temperature : 23.2 °C; Liquid Temperature : 22.3 °C**

DASY5 Configuration:

- Probe: EX3DV4 - SN3976; ConvF(7.26, 7.26, 7.26); Calibrated: 2015/2/26;
- Sensor-Surface: 2mm (Mechanical Surface Detection)
- Electronics: DAE4 Sn1424; Calibrated: 2015/2/20
- Phantom: ELI v5.0; Type: QDOVA002AA; Serial: TP:1238
- Measurement SW: DASY52, Version 52.8 (8); SEMCAD X Version 14.6.10 (7331)

**Ch6/Area Scan (201x271x1):** Interpolated grid: dx=1.200 mm, dy=1.200 mm

Maximum value of SAR (interpolated) = 0.636 W/kg

**Ch6/Zoom Scan (5x5x7)/Cube 0:** Measurement grid: dx=8mm, dy=8mm, dz=5mm

Reference Value = 17.19 V/m; Power Drift = -0.03 dB

Peak SAR (extrapolated) = 0.906 W/kg

**SAR(1 g) = 0.412 W/kg; SAR(10 g) = 0.191 W/kg**

Maximum value of SAR (measured) = 0.637 W/kg

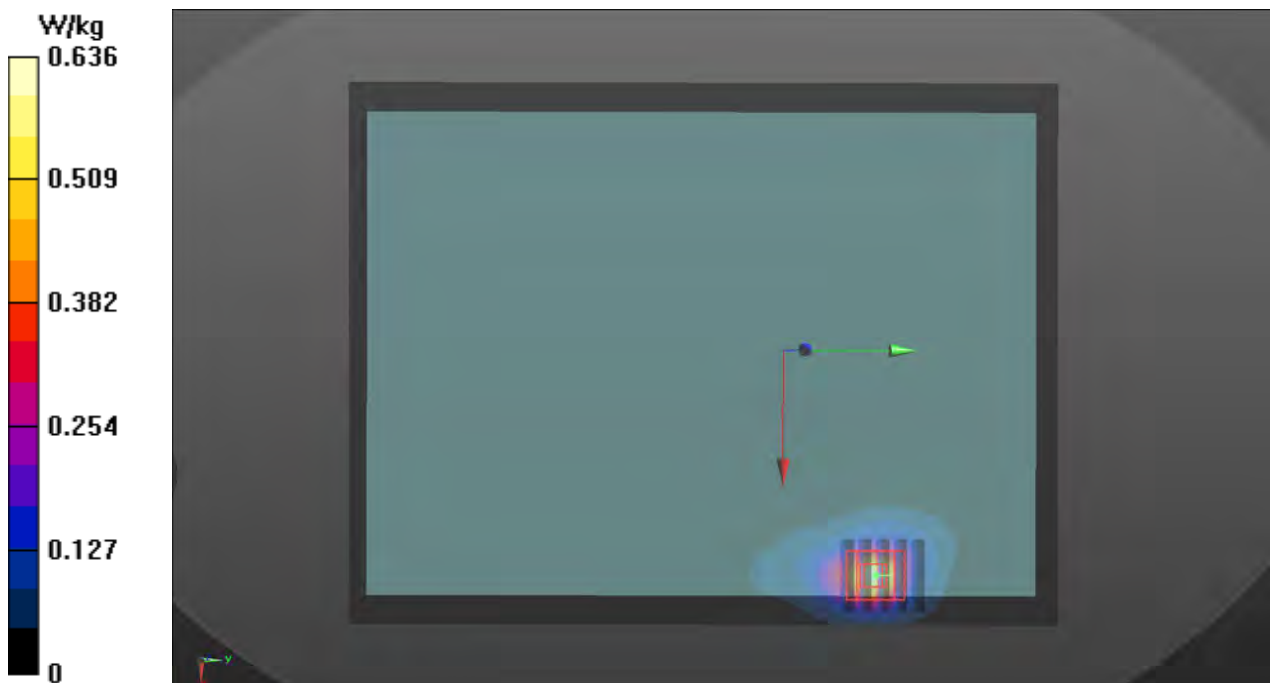

### P04 802.11b\_Edge3\_0cm\_Ch6\_Ant A\_Inpaq

#### DUT: 512732-02\_Inpaq

Communication System: WLAN\_2.4G; Frequency: 2437 MHz; Duty Cycle: 1:1  
Medium: B2450\_150718 Medium parameters used:  $f = 2437$  MHz;  $\sigma = 1.989$  S/m;  $\epsilon_r = 51.324$ ;  $\rho = 1000$  kg/m<sup>3</sup>

**Ambient Temperature : 23.2 °C; Liquid Temperature : 22.3 °C**

#### DASY5 Configuration:

- Probe: EX3DV4 - SN3976; ConvF(7.26, 7.26, 7.26); Calibrated: 2015/2/26;
- Sensor-Surface: 2mm (Mechanical Surface Detection)
- Electronics: DAE4 Sn1424; Calibrated: 2015/2/20
- Phantom: ELI v5.0; Type: QDOVA002AA; Serial: TP:1238
- Measurement SW: DASY52, Version 52.8 (8); SEMCAD X Version 14.6.10 (7331)

**Ch6/Area Scan (71x271x1):** Interpolated grid: dx=1.200 mm, dy=1.200 mm

Maximum value of SAR (interpolated) = 1.32 W/kg

**Ch6/Zoom Scan (5x5x7)/Cube 0:** Measurement grid: dx=8mm, dy=8mm, dz=5mm

Reference Value = 13.48 V/m; Power Drift = -0.05 dB

Peak SAR (extrapolated) = 0.791 W/kg

**SAR(1 g) = 0.348 W/kg; SAR(10 g) = 0.149 W/kg**

Maximum value of SAR (measured) = 0.492 W/kg

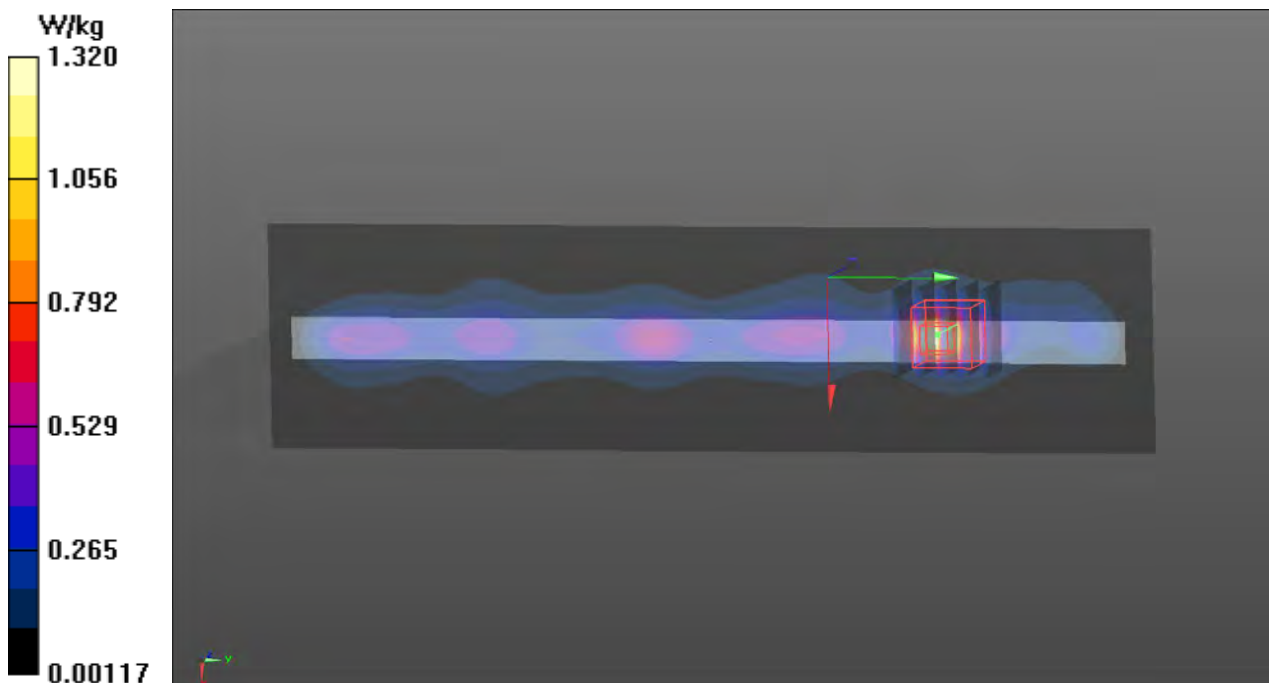

### P05 802.11b\_Rear Face\_0cm\_Ch11\_Ant B\_ACON

**DUT: 512732-02\_ACON**

Communication System: WLAN\_2.4G; Frequency: 2462 MHz; Duty Cycle: 1:1  
Medium: B2450\_150720 Medium parameters used:  $f = 2462$  MHz;  $\sigma = 2.018$  S/m;  $\epsilon_r = 51.266$ ;  $\rho = 1000$  kg/m<sup>3</sup>

**Ambient Temperature : 23.2 °C; Liquid Temperature : 22.6 °C**

DASY5 Configuration:

- Probe: EX3DV4 - SN3976; ConvF(7.26, 7.26, 7.26); Calibrated: 2015/2/26;
- Sensor-Surface: 2mm (Mechanical Surface Detection)
- Electronics: DAE4 Sn1424; Calibrated: 2015/2/20
- Phantom: ELI v5.0; Type: QDOVA002AA; Serial: TP:1238
- Measurement SW: DASY52, Version 52.8 (8); SEMCAD X Version 14.6.10 (7331)

**Ch11/Area Scan (201x271x1):** Interpolated grid: dx=1.200 mm, dy=1.200 mm  
Maximum value of SAR (interpolated) = 0.269 W/kg

**Ch11/Zoom Scan (5x5x7)/Cube 0:** Measurement grid: dx=8mm, dy=8mm, dz=5mm

Reference Value = 11.74 V/m; Power Drift = -0.09 dB

Peak SAR (extrapolated) = 0.385 W/kg

**SAR(1 g) = 0.184 W/kg; SAR(10 g) = 0.090 W/kg**

Maximum value of SAR (measured) = 0.272 W/kg

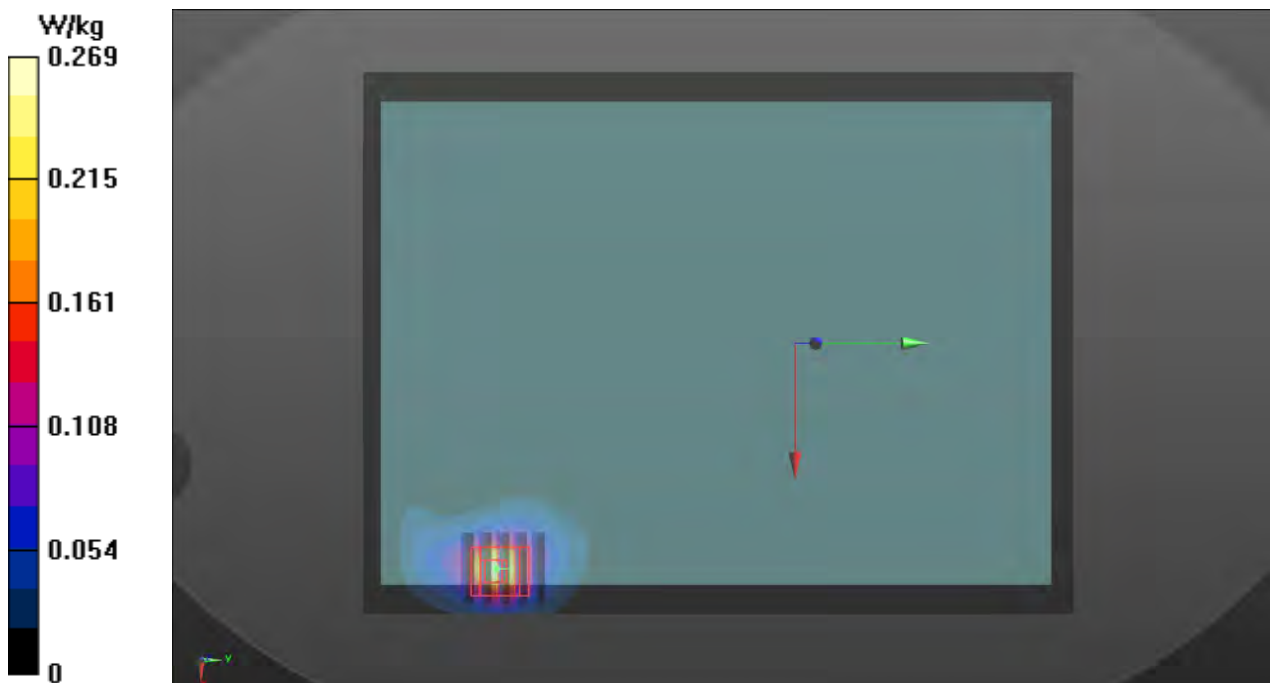

## P06 802.11b\_Edge 3\_0cm\_Ch11\_Ant B\_ACON

**DUT: 512732-02\_ACON**

Communication System: WLAN\_2.4G; Frequency: 2462 MHz; Duty Cycle: 1:1  
Medium: B2450\_150720 Medium parameters used:  $f = 2462$  MHz;  $\sigma = 2.018$  S/m;  $\epsilon_r = 51.266$ ;  $\rho = 1000$  kg/m<sup>3</sup>

**Ambient Temperature : 23.2 °C; Liquid Temperature : 22.6 °C**

DASY5 Configuration:

- Probe: EX3DV4 - SN3976; ConvF(7.26, 7.26, 7.26); Calibrated: 2015/2/26;
- Sensor-Surface: 2mm (Mechanical Surface Detection)
- Electronics: DAE4 Sn1424; Calibrated: 2015/2/20
- Phantom: ELI v5.0; Type: QDOVA002AA; Serial: TP:1238
- Measurement SW: DASY52, Version 52.8 (8); SEMCAD X Version 14.6.10 (7331)

**Ch11/Area Scan (31x271x1):** Interpolated grid: dx=1.200 mm, dy=1.200 mm

Maximum value of SAR (interpolated) = 0.333 W/kg

**Ch11/Zoom Scan (5x5x7)/Cube 0:** Measurement grid: dx=8mm, dy=8mm, dz=5mm

Reference Value = 10.93 V/m; Power Drift = -0.11 dB

Peak SAR (extrapolated) = 0.451 W/kg

**SAR(1 g) = 0.209 W/kg; SAR(10 g) = 0.092 W/kg**

Maximum value of SAR (measured) = 0.320 W/kg

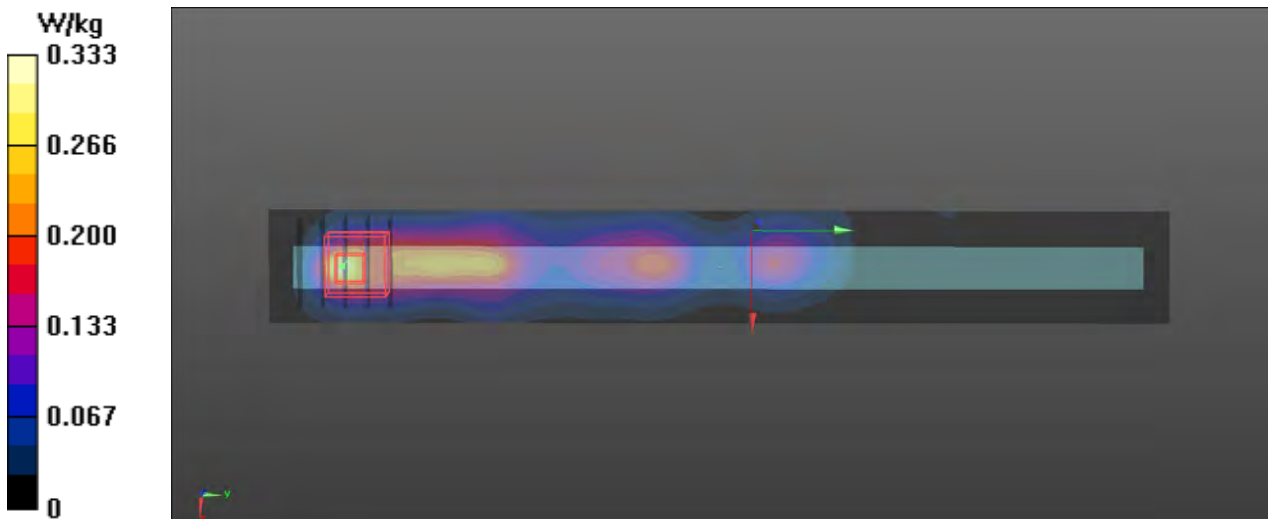

### P07 802.11b\_Rear Face\_0cm\_Ch11\_Ant B\_Inpaq

**DUT: 512732-02\_Inpaq**

Communication System: WLAN\_2.4G; Frequency: 2462 MHz; Duty Cycle: 1:1  
Medium: B2450\_150718 Medium parameters used:  $f = 2462$  MHz;  $\sigma = 1.988$  S/m;  $\epsilon_r = 51.322$ ;  $\rho = 1000$  kg/m<sup>3</sup>

**Ambient Temperature : 23.2 °C; Liquid Temperature : 22.3 °C**

DASY5 Configuration:

- Probe: EX3DV4 - SN3976; ConvF(7.26, 7.26, 7.26); Calibrated: 2015/2/26;
- Sensor-Surface: 2mm (Mechanical Surface Detection)
- Electronics: DAE4 Sn1424; Calibrated: 2015/2/20
- Phantom: ELI v5.0; Type: QDOVA002AA; Serial: TP:1238
- Measurement SW: DASY52, Version 52.8 (8); SEMCAD X Version 14.6.10 (7331)

**Ch11/Area Scan (201x271x1):** Interpolated grid: dx=1.200 mm, dy=1.200 mm  
Maximum value of SAR (interpolated) = 0.414 W/kg

**Ch11/Zoom Scan (5x5x7)/Cube 0:** Measurement grid: dx=8mm, dy=8mm, dz=5mm  
Reference Value = 14.34 V/m; Power Drift = -0.11 dB  
Peak SAR (extrapolated) = 0.721 W/kg  
**SAR(1 g) = 0.329 W/kg; SAR(10 g) = 0.151 W/kg**  
Maximum value of SAR (measured) = 0.506 W/kg

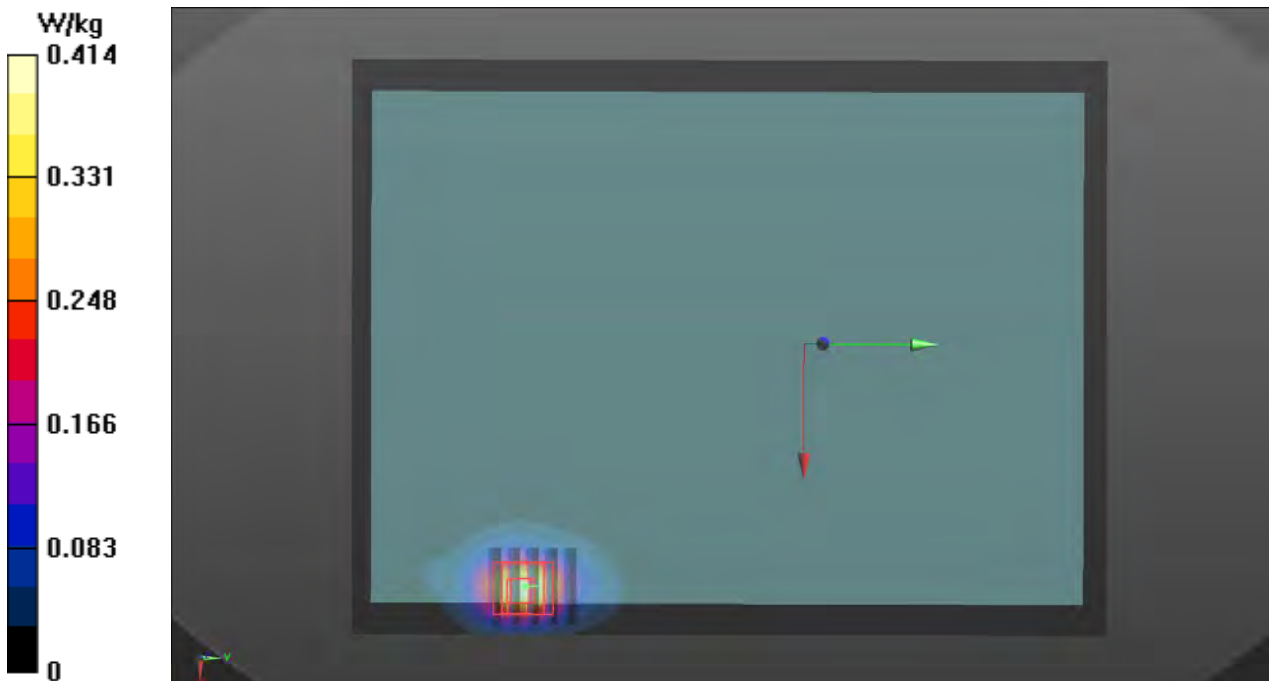



## P08 802.11b\_Edge 3\_0cm\_Ch11\_Ant B\_Inpaq

### DUT: 512732-02\_Inpaq

Communication System: WLAN\_2.4G; Frequency: 2462 MHz; Duty Cycle: 1:1

Medium: B2450\_150718 Medium parameters used:  $f = 2462$  MHz;  $\sigma = 1.988$  S/m;  $\epsilon_r = 51.322$ ;  $\rho = 1000$  kg/m<sup>3</sup>

**Ambient Temperature : 23.2 °C; Liquid Temperature : 22.3 °C**

#### DASY5 Configuration:

- Probe: EX3DV4 - SN3976; ConvF(7.26, 7.26, 7.26); Calibrated: 2015/2/26;
- Sensor-Surface: 2mm (Mechanical Surface Detection)
- Electronics: DAE4 Sn1424; Calibrated: 2015/2/20
- Phantom: ELI v5.0; Type: QDOVA002AA; Serial: TP:1238
- Measurement SW: DASY52, Version 52.8 (8); SEMCAD X Version 14.6.10 (7331)

**Ch11/Area Scan (31x271x1):** Interpolated grid: dx=1.200 mm, dy=1.200 mm

Maximum value of SAR (interpolated) = 0.377 W/kg

**Ch11/Zoom Scan (5x5x7)/Cube 0:** Measurement grid: dx=8mm, dy=8mm, dz=5mm

Reference Value = 13.57 V/m; Power Drift = -0.14 dB

Peak SAR (extrapolated) = 0.783 W/kg

**SAR(1 g) = 0.341 W/kg; SAR(10 g) = 0.146 W/kg**

Maximum value of SAR (measured) = 0.478 W/kg

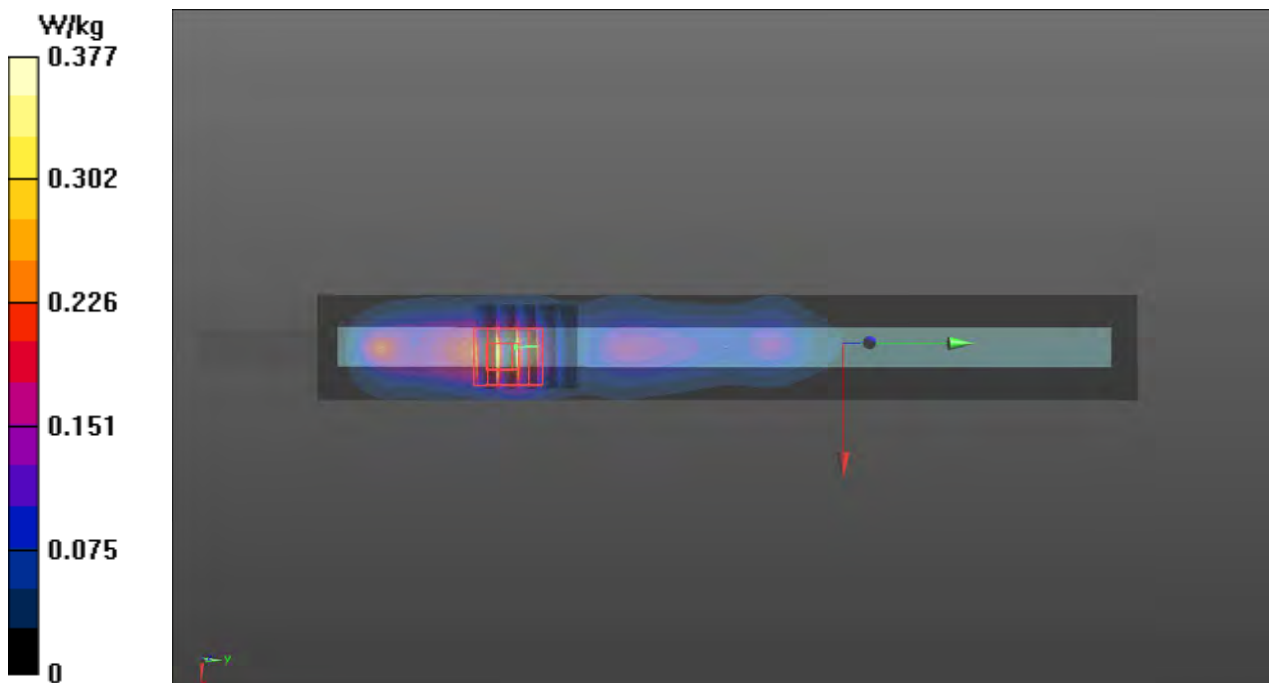

## P09 802.11a\_Rear Face\_0cm\_Ch48\_Ant A\_ACON

**DUT: 512732-02\_ACON**

Communication System: WLAN\_5G; Frequency: 5240 MHz; Duty Cycle: 1:1  
Medium: B5G\_150720 Medium parameters used:  $f = 5240$  MHz;  $\sigma = 5.416$  S/m;  $\epsilon_r = 48.651$ ;  $\rho = 1000$  kg/m<sup>3</sup>

**Ambient Temperature : 23.4 °C; Liquid Temperature : 22.5 °C**

DASY5 Configuration:

- Probe: EX3DV4 - SN3976; ConvF(4.52, 4.52, 4.52); Calibrated: 2015/2/26;
- Sensor-Surface: 2mm (Mechanical Surface Detection)
- Electronics: DAE4 Sn1424; Calibrated: 2015/2/20
- Phantom: ELI v5.0; Type: QDOVA002AA; Serial: TP:1238
- Measurement SW: DASY52, Version 52.8 (8); SEMCAD X Version 14.6.10 (7331)

**Ch48/Area Scan (241x321x1):** Interpolated grid: dx=1.000 mm, dy=1.000 mm  
Maximum value of SAR (interpolated) = 0.471 W/kg

**Ch48/Zoom Scan (6x6x12)/Cube 0:** Measurement grid: dx=5mm, dy=5mm, dz=2mm

Reference Value = 10.18 V/m; Power Drift = -0.01 dB

Peak SAR (extrapolated) = 1.00 W/kg

**SAR(1 g) = 0.252 W/kg; SAR(10 g) = 0.087 W/kg**

Maximum value of SAR (measured) = 0.468 W/kg



### P10 802.11a\_Edge3\_0cm\_Ch48\_Ant A\_ACON

**DUT: 512732-02\_ACON**

Communication System: WLAN\_5G; Frequency: 5240 MHz; Duty Cycle: 1:1  
Medium: B5G\_150720 Medium parameters used:  $f = 5240$  MHz;  $\sigma = 5.416$  S/m;  $\epsilon_r = 48.651$ ;  $\rho = 1000$  kg/m<sup>3</sup>

**Ambient Temperature : 23.4 °C; Liquid Temperature : 22.5 °C**

DASY5 Configuration:

- Probe: EX3DV4 - SN3976; ConvF(4.52, 4.52, 4.52); Calibrated: 2015/2/26;
- Sensor-Surface: 2mm (Mechanical Surface Detection)
- Electronics: DAE4 Sn1424; Calibrated: 2015/2/20
- Phantom: ELI v5.0; Type: QDOVA002AA; Serial: TP:1238
- Measurement SW: DASY52, Version 52.8 (8); SEMCAD X Version 14.6.10 (7331)

**Ch48/Area Scan (41x321x1):** Interpolated grid: dx=1.000 mm, dy=1.000 mm

Maximum value of SAR (interpolated) = 0.492 W/kg

**Ch48/Zoom Scan (6x6x12)/Cube 0:** Measurement grid: dx=5mm, dy=5mm, dz=2mm

Reference Value = 10.14 V/m; Power Drift = -0.15 dB

Peak SAR (extrapolated) = 1.08 W/kg

**SAR(1 g) = 0.268 W/kg; SAR(10 g) = 0.096 W/kg**

Maximum value of SAR (measured) = 0.497 W/kg

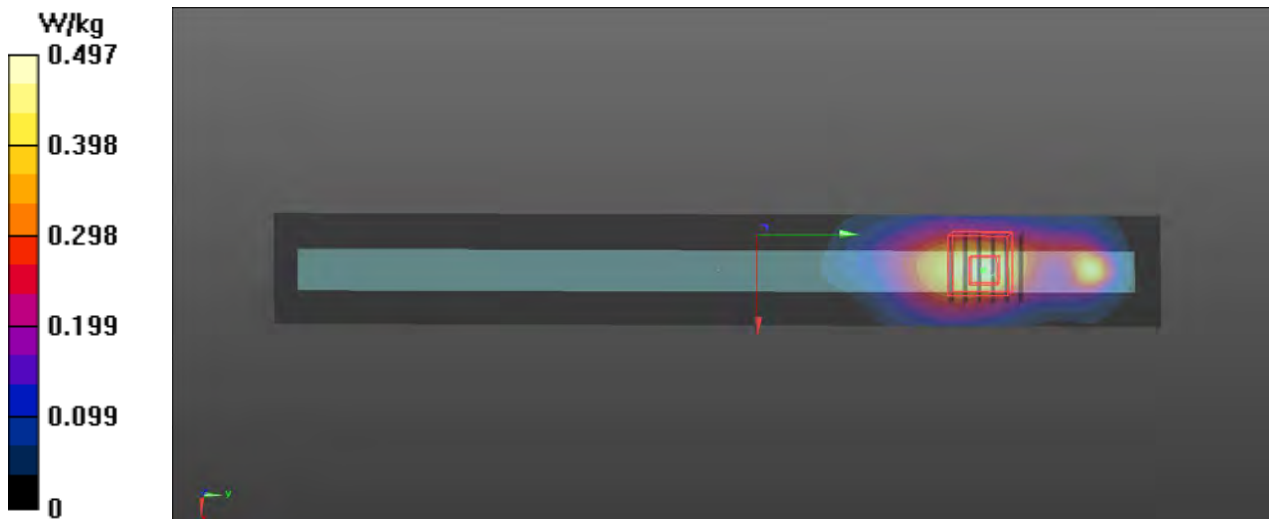

**P11 802.11a\_Rear Face\_0cm\_Ch48\_Ant A\_Inpaq****DUT: 512732-02\_Inpaq**

Communication System: WLAN\_5G; Frequency: 5240 MHz; Duty Cycle: 1:1

Medium: B5G\_150717 Medium parameters used:  $f = 5240$  MHz;  $\sigma = 5.418$  S/m;  $\epsilon_r = 48.654$ ;  $\rho = 1000$  kg/m<sup>3</sup>

**Ambient Temperature : 23.2 °C; Liquid Temperature : 22.6 °C**

**DASY5 Configuration:**

- Probe: EX3DV4 - SN3976; ConvF(4.52, 4.52, 4.52); Calibrated: 2015/2/26;
- Sensor-Surface: 2mm (Mechanical Surface Detection)
- Electronics: DAE4 Sn1424; Calibrated: 2015/2/20
- Phantom: ELI v5.0; Type: QDOVA002AA; Serial: TP:1238
- Measurement SW: DASY52, Version 52.8 (8); SEMCAD X Version 14.6.10 (7331)

**Ch48/Area Scan (241x321x1):** Interpolated grid: dx=1.000 mm, dy=1.000 mm

Maximum value of SAR (interpolated) = 0.747 W/kg

**Ch48/Zoom Scan (6x6x12)/Cube 0:** Measurement grid: dx=5mm, dy=5mm, dz=2mm

Reference Value = 12.11 V/m; Power Drift = -0.08 dB

Peak SAR (extrapolated) = 1.41 W/kg

**SAR(1 g) = 0.378 W/kg; SAR(10 g) = 0.134 W/kg**

Maximum value of SAR (measured) = 0.711 W/kg

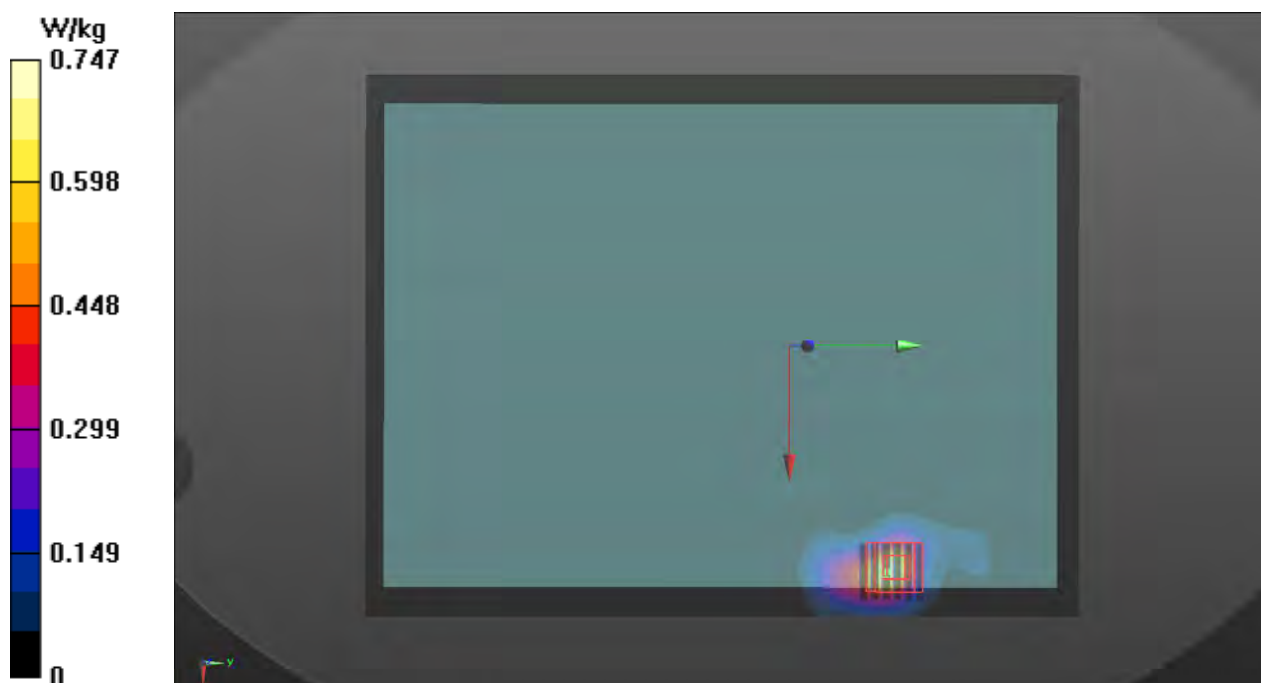

### P12 802.11a\_Edge3\_0cm\_Ch48\_Ant A\_Inpaq

**DUT: 512732-02\_Inpaq**

Communication System: WLAN\_5G; Frequency: 5240 MHz; Duty Cycle: 1:1

Medium: B5G\_150717 Medium parameters used:  $f = 5240$  MHz;  $\sigma = 5.418$  S/m;  $\epsilon_r = 48.654$ ;  $\rho = 1000$  kg/m<sup>3</sup>

**Ambient Temperature : 23.2 °C; Liquid Temperature : 22.6 °C**

DASY5 Configuration:

- Probe: EX3DV4 - SN3976; ConvF(4.52, 4.52, 4.52); Calibrated: 2015/2/26;
- Sensor-Surface: 2mm (Mechanical Surface Detection)
- Electronics: DAE4 Sn1424; Calibrated: 2015/2/20
- Phantom: ELI v5.0; Type: QDOVA002AA; Serial: TP:1238
- Measurement SW: DASY52, Version 52.8 (8); SEMCAD X Version 14.6.10 (7331)

**Ch48/Area Scan (21x321x1):** Interpolated grid: dx=1.000 mm, dy=1.000 mm

Maximum value of SAR (interpolated) = 1.34 W/kg

**Ch48/Zoom Scan (6x6x12)/Cube 0:** Measurement grid: dx=5mm, dy=5mm, dz=2mm

Reference Value = 0.9370 V/m; Power Drift = 0.05 dB

Peak SAR (extrapolated) = 2.79 W/kg

**SAR(1 g) = 0.682 W/kg; SAR(10 g) = 0.220 W/kg**

Maximum value of SAR (measured) = 1.36 W/kg

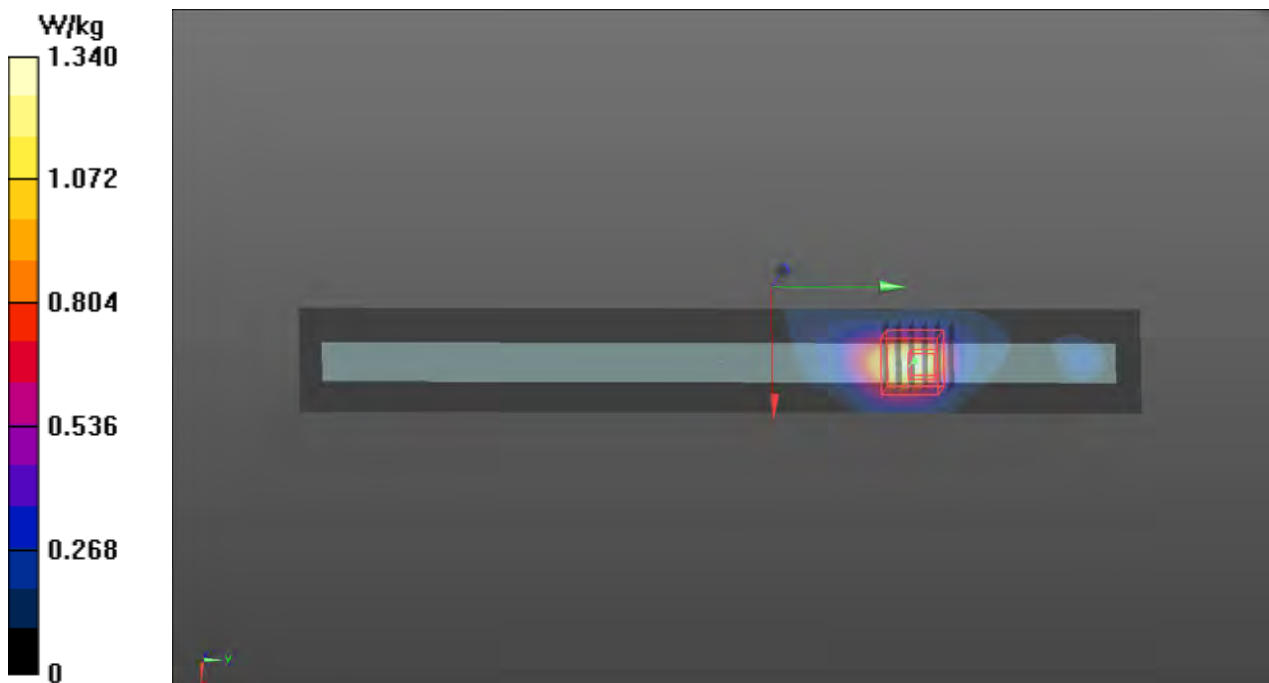

**P13 802.11a\_Rear Face\_0cm\_Ch36\_Ant B\_ACON****DUT: 512732-02\_ACON**

Communication System: WLAN\_5G; Frequency: 5180 MHz; Duty Cycle: 1:1

Medium: B5G\_150720 Medium parameters used:  $f = 5180$  MHz;  $\sigma = 5.339$  S/m;  $\epsilon_r = 48.775$ ;  $\rho = 1000$  kg/m<sup>3</sup>**Ambient Temperature : 23.4 °C; Liquid Temperature : 22.5 °C**

DASY5 Configuration:

- Probe: EX3DV4 - SN3976; ConvF(4.52, 4.52, 4.52); Calibrated: 2015/2/26;
- Sensor-Surface: 2mm (Mechanical Surface Detection)
- Electronics: DAE4 Sn1424; Calibrated: 2015/2/20
- Phantom: ELI v5.0; Type: QDOVA002AA; Serial: TP:1238
- Measurement SW: DASY52, Version 52.8 (8); SEMCAD X Version 14.6.10 (7331)

**Ch36/Area Scan (241x321x1):** Interpolated grid: dx=1.000 mm, dy=1.000 mm

Maximum value of SAR (interpolated) = 0.327 W/kg

**Ch36/Zoom Scan (6x6x12)/Cube 0:** Measurement grid: dx=5mm, dy=5mm, dz=2mm

Reference Value = 8.390 V/m; Power Drift = -0.06 dB

Peak SAR (extrapolated) = 0.688 W/kg

**SAR(1 g) = 0.172 W/kg; SAR(10 g) = 0.059 W/kg**

Maximum value of SAR (measured) = 0.332 W/kg

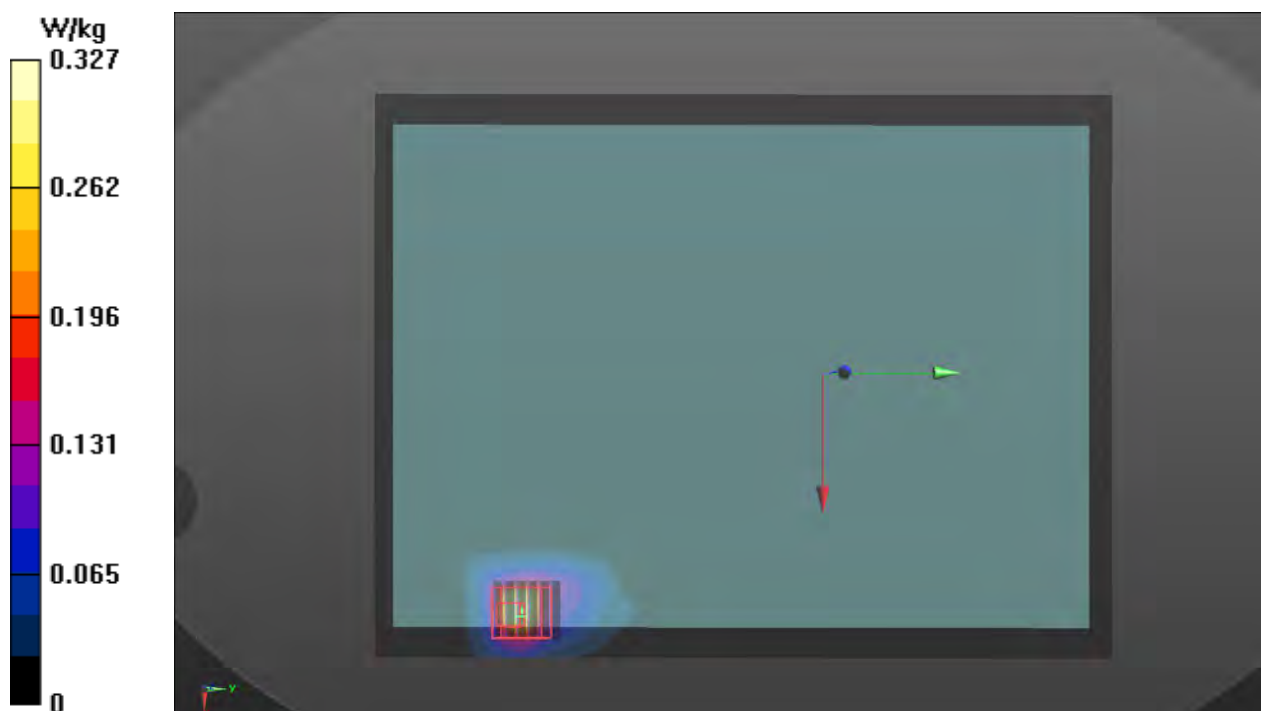

### P14 802.11a\_Edge3\_0cm\_Ch36\_Ant B\_ACON

**DUT: 512732-02\_ACON**

Communication System: WLAN\_5G; Frequency: 5180 MHz; Duty Cycle: 1:1  
Medium: B5G\_150720 Medium parameters used:  $f = 5180$  MHz;  $\sigma = 5.339$  S/m;  $\epsilon_r = 48.775$ ;  $\rho = 1000$  kg/m<sup>3</sup>

**Ambient Temperature : 23.4 °C; Liquid Temperature : 22.5 °C**

DASY5 Configuration:

- Probe: EX3DV4 - SN3976; ConvF(4.52, 4.52, 4.52); Calibrated: 2015/2/26;
- Sensor-Surface: 2mm (Mechanical Surface Detection)
- Electronics: DAE4 Sn1424; Calibrated: 2015/2/20
- Phantom: ELI v5.0; Type: QDOVA002AA; Serial: TP:1238
- Measurement SW: DASY52, Version 52.8 (8); SEMCAD X Version 14.6.10 (7331)

**Ch36/Area Scan (41x321x1):** Interpolated grid: dx=1.000 mm, dy=1.000 mm

Maximum value of SAR (interpolated) = 0.647 W/kg

**Ch36/Zoom Scan (6x6x12)/Cube 0:** Measurement grid: dx=5mm, dy=5mm, dz=2mm

Reference Value = 11.91 V/m; Power Drift = -0.04 dB

Peak SAR (extrapolated) = 1.50 W/kg

**SAR(1 g) = 0.402 W/kg; SAR(10 g) = 0.137 W/kg**

Maximum value of SAR (measured) = 0.741 W/kg

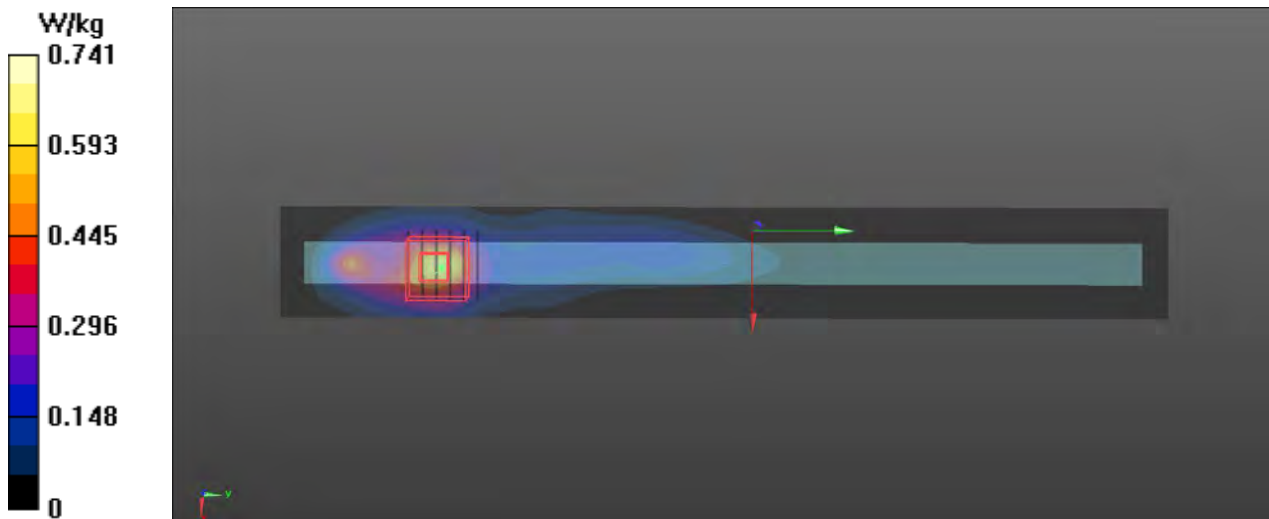

## P15 802.11a\_Rear Face\_0cm\_Ch36\_Ant B\_Inpaq

### DUT: 512732-02\_Inpaq

Communication System: WLAN\_5G; Frequency: 5180 MHz; Duty Cycle: 1:1  
Medium: B5G\_150717 Medium parameters used:  $f = 5180$  MHz;  $\sigma = 5.34$  S/m;  $\epsilon_r = 48.779$ ;  $\rho = 1000$  kg/m<sup>3</sup>

**Ambient Temperature : 23.2 °C; Liquid Temperature : 22.6 °C**

#### DASY5 Configuration:

- Probe: EX3DV4 - SN3976; ConvF(4.52, 4.52, 4.52); Calibrated: 2015/2/26;
- Sensor-Surface: 2mm (Mechanical Surface Detection)
- Electronics: DAE4 Sn1424; Calibrated: 2015/2/20
- Phantom: ELI v5.0; Type: QDOVA002AA; Serial: TP:1238
- Measurement SW: DASY52, Version 52.8 (8); SEMCAD X Version 14.6.10 (7331)

**Ch36/Area Scan (241x321x1):** Interpolated grid: dx=1.000 mm, dy=1.000 mm  
Maximum value of SAR (interpolated) = 0.501 W/kg

**Ch36/Zoom Scan (6x6x12)/Cube 0:** Measurement grid: dx=5mm, dy=5mm, dz=2mm

Reference Value = 8.435 V/m; Power Drift = -0.04 dB

Peak SAR (extrapolated) = 1.07 W/kg

**SAR(1 g) = 0.267 W/kg; SAR(10 g) = 0.093 W/kg**

Maximum value of SAR (measured) = 0.487 W/kg

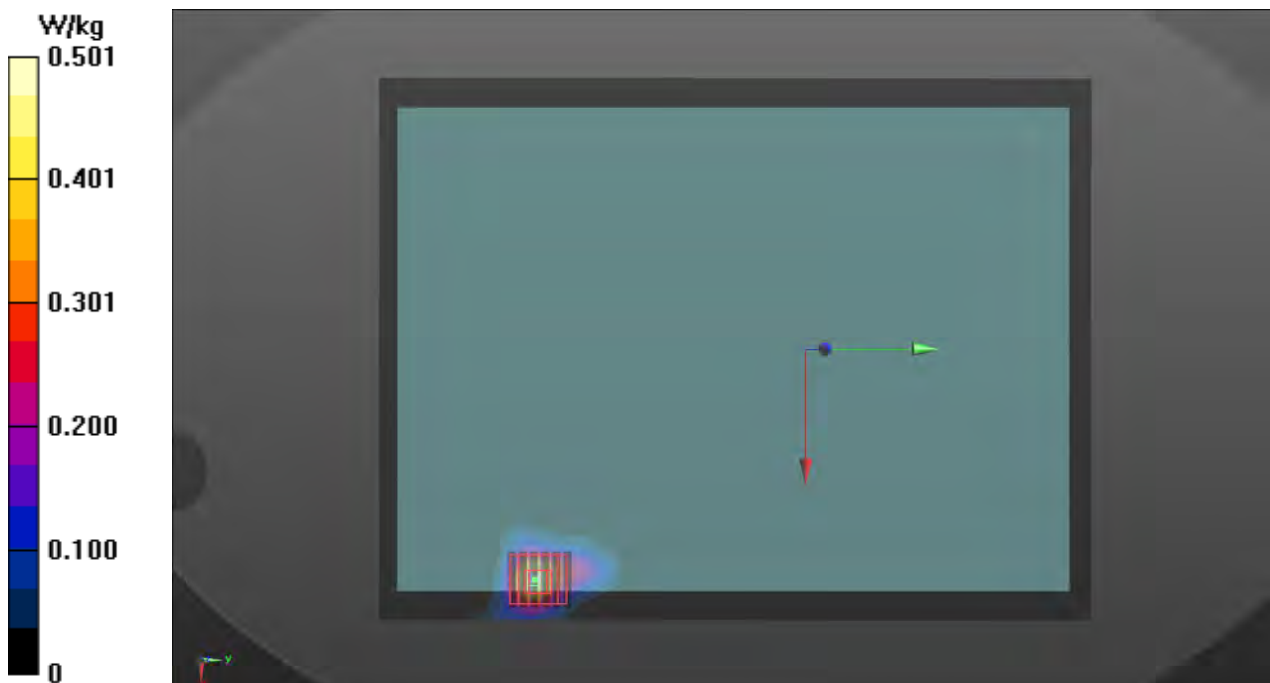



## P16 802.11a\_Edge3\_0cm\_Ch36\_Ant B\_Inpaq

### DUT: 512732-02\_Inpaq

Communication System: WLAN\_5G; Frequency: 5180 MHz; Duty Cycle: 1:1  
Medium: B5G\_150717 Medium parameters used:  $f = 5180$  MHz;  $\sigma = 5.34$  S/m;  $\epsilon_r = 48.779$ ;  $\rho = 1000$  kg/m<sup>3</sup>

**Ambient Temperature : 23.2 °C; Liquid Temperature : 22.6 °C**

#### DASY5 Configuration:

- Probe: EX3DV4 - SN3976; ConvF(4.52, 4.52, 4.52); Calibrated: 2015/2/26;
- Sensor-Surface: 2mm (Mechanical Surface Detection)
- Electronics: DAE4 Sn1424; Calibrated: 2015/2/20
- Phantom: ELI v5.0; Type: QDOVA002AA; Serial: TP:1238
- Measurement SW: DASY52, Version 52.8 (8); SEMCAD X Version 14.6.10 (7331)

**Ch36/Area Scan (41x321x1):** Interpolated grid: dx=1.000 mm, dy=1.000 mm

Maximum value of SAR (interpolated) = 0.734 W/kg

**Ch36/Zoom Scan (6x6x12)/Cube 0:** Measurement grid: dx=5mm, dy=5mm, dz=2mm

Reference Value = 11.64 V/m; Power Drift = -0.02 dB

Peak SAR (extrapolated) = 3.07 W/kg

**SAR(1 g) = 0.648 W/kg; SAR(10 g) = 0.160 W/kg**

Maximum value of SAR (measured) = 1.32 W/kg

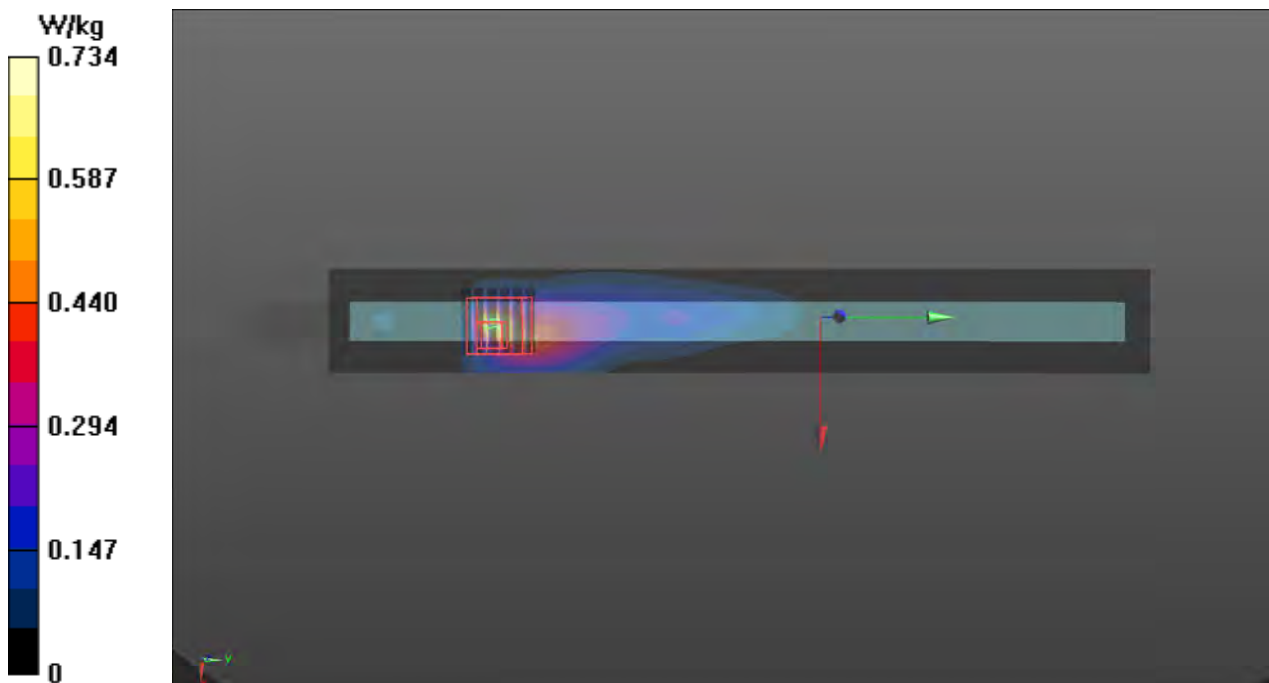

**P17 802.11a\_Rear Face\_0cm\_Ch64\_Ant A\_ACON****DUT: 512732-02\_ACON**

Communication System: WLAN\_5G; Frequency: 5320 MHz; Duty Cycle: 1:1  
Medium: B5G\_150720 Medium parameters used:  $f = 5320$  MHz;  $\sigma = 5.524$  S/m;  $\epsilon_r = 48.523$ ;  $\rho = 1000$  kg/m<sup>3</sup>

**Ambient Temperature** : 23.4 °C; **Liquid Temperature** : 22.5 °C

**DASY5 Configuration:**

- Probe: EX3DV4 - SN3976; ConvF(4.52, 4.52, 4.52); Calibrated: 2015/2/26;
- Sensor-Surface: 2mm (Mechanical Surface Detection)
- Electronics: DAE4 Sn1424; Calibrated: 2015/2/20
- Phantom: ELI v5.0; Type: QDOVA002AA; Serial: TP:1238
- Measurement SW: DASY52, Version 52.8 (8); SEMCAD X Version 14.6.10 (7331)

**Ch64/Area Scan (241x321x1):** Interpolated grid: dx=1.000 mm, dy=1.000 mm

Maximum value of SAR (interpolated) = 0.501 W/kg

**Ch64/Zoom Scan (6x6x12)/Cube 0:** Measurement grid: dx=5mm, dy=5mm, dz=2mm

Reference Value = 9.709 V/m; Power Drift = -0.06 dB

Peak SAR (extrapolated) = 0.962 W/kg

**SAR(1 g) = 0.233 W/kg; SAR(10 g) = 0.080 W/kg**

Maximum value of SAR (measured) = 0.439 W/kg



## P18 802.11a\_Edge3\_0cm\_Ch64\_Ant A\_ACON

**DUT: 512732-02\_ACON**

Communication System: WLAN\_5G; Frequency: 5320 MHz; Duty Cycle: 1:1  
Medium: B5G\_150720 Medium parameters used:  $f = 5320$  MHz;  $\sigma = 5.524$  S/m;  $\epsilon_r = 48.523$ ;  $\rho = 1000$  kg/m<sup>3</sup>

**Ambient Temperature : 23.4 °C; Liquid Temperature : 22.5 °C**

DASY5 Configuration:

- Probe: EX3DV4 - SN3976; ConvF(4.52, 4.52, 4.52); Calibrated: 2015/2/26;
- Sensor-Surface: 2mm (Mechanical Surface Detection)
- Electronics: DAE4 Sn1424; Calibrated: 2015/2/20
- Phantom: ELI v5.0; Type: QDOVA002AA; Serial: TP:1238
- Measurement SW: DASY52, Version 52.8 (8); SEMCAD X Version 14.6.10 (7331)

**Ch64/Area Scan (41x321x1):** Interpolated grid: dx=1.000 mm, dy=1.000 mm

Maximum value of SAR (interpolated) = 0.467 W/kg

**Ch64/Zoom Scan (6x6x12)/Cube 0:** Measurement grid: dx=5mm, dy=5mm, dz=2mm

Reference Value = 9.795 V/m; Power Drift = -0.13 dB

Peak SAR (extrapolated) = 0.927 W/kg

**SAR(1 g) = 0.227 W/kg; SAR(10 g) = 0.079 W/kg**

Maximum value of SAR (measured) = 0.417 W/kg

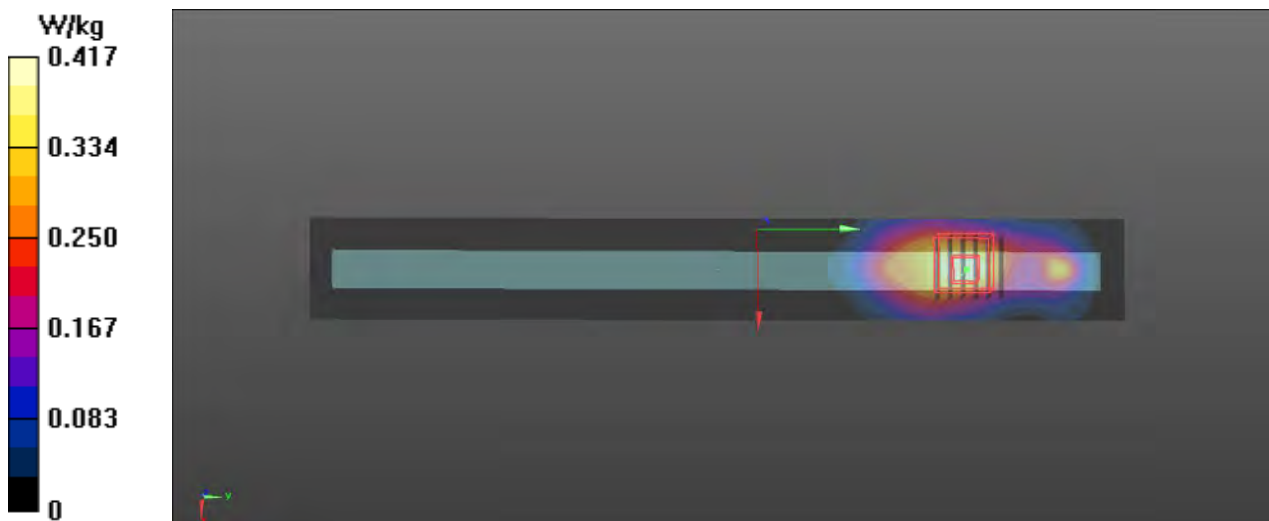

## P19 802.11a\_Rear Face\_0cm\_Ch64\_Ant A\_Inpaq

### DUT: 512732-02\_Inpaq

Communication System: WLAN\_5G; Frequency: 5320 MHz; Duty Cycle: 1:1

Medium: B5G\_150717 Medium parameters used:  $f = 5320$  MHz;  $\sigma = 5.526$  S/m;  $\epsilon_r = 48.524$ ;  $\rho = 1000$  kg/m<sup>3</sup>

**Ambient Temperature : 23.2 °C; Liquid Temperature : 22.6 °C**

#### DASY5 Configuration:

- Probe: EX3DV4 - SN3976; ConvF(4.52, 4.52, 4.52); Calibrated: 2015/2/26;
- Sensor-Surface: 2mm (Mechanical Surface Detection)
- Electronics: DAE4 Sn1424; Calibrated: 2015/2/20
- Phantom: ELI v5.0; Type: QDOVA002AA; Serial: TP:1238
- Measurement SW: DASY52, Version 52.8 (8); SEMCAD X Version 14.6.10 (7331)

**Ch64/Area Scan (241x321x1):** Interpolated grid: dx=1.000 mm, dy=1.000 mm

Maximum value of SAR (interpolated) = 0.557 W/kg

**Ch64/Zoom Scan (6x6x12)/Cube 0:** Measurement grid: dx=5mm, dy=5mm, dz=2mm

Reference Value = 10.32 V/m; Power Drift = 0.02 dB

Peak SAR (extrapolated) = 1.08 W/kg

**SAR(1 g) = 0.280 W/kg; SAR(10 g) = 0.100 W/kg**

Maximum value of SAR (measured) = 0.534 W/kg



## P20 802.11a\_Edge3\_0cm\_Ch64\_Ant A\_Inpaq

**DUT: 512732-02\_Inpaq**

Communication System: WLAN\_5G; Frequency: 5320 MHz; Duty Cycle: 1:1

Medium: B5G\_150717 Medium parameters used:  $f = 5320$  MHz;  $\sigma = 5.526$  S/m;  $\epsilon_r = 48.524$ ;  $\rho = 1000$  kg/m<sup>3</sup>

**Ambient Temperature : 23.2 °C; Liquid Temperature : 22.6 °C**

DASY5 Configuration:

- Probe: EX3DV4 - SN3976; ConvF(4.52, 4.52, 4.52); Calibrated: 2015/2/26;
- Sensor-Surface: 2mm (Mechanical Surface Detection)
- Electronics: DAE4 Sn1424; Calibrated: 2015/2/20
- Phantom: ELI v5.0; Type: QDOVA002AA; Serial: TP:1238
- Measurement SW: DASY52, Version 52.8 (8); SEMCAD X Version 14.6.10 (7331)

**Ch64/Area Scan (41x321x1):** Interpolated grid: dx=1.000 mm, dy=1.000 mm

Maximum value of SAR (interpolated) = 1.24 W/kg

**Ch64/Zoom Scan (6x6x12)/Cube 0:** Measurement grid: dx=5mm, dy=5mm, dz=2mm

Reference Value = 15.03 V/m; Power Drift = -0.10 dB

Peak SAR (extrapolated) = 2.42 W/kg

**SAR(1 g) = 0.599 W/kg; SAR(10 g) = 0.199 W/kg**

Maximum value of SAR (measured) = 1.10 W/kg

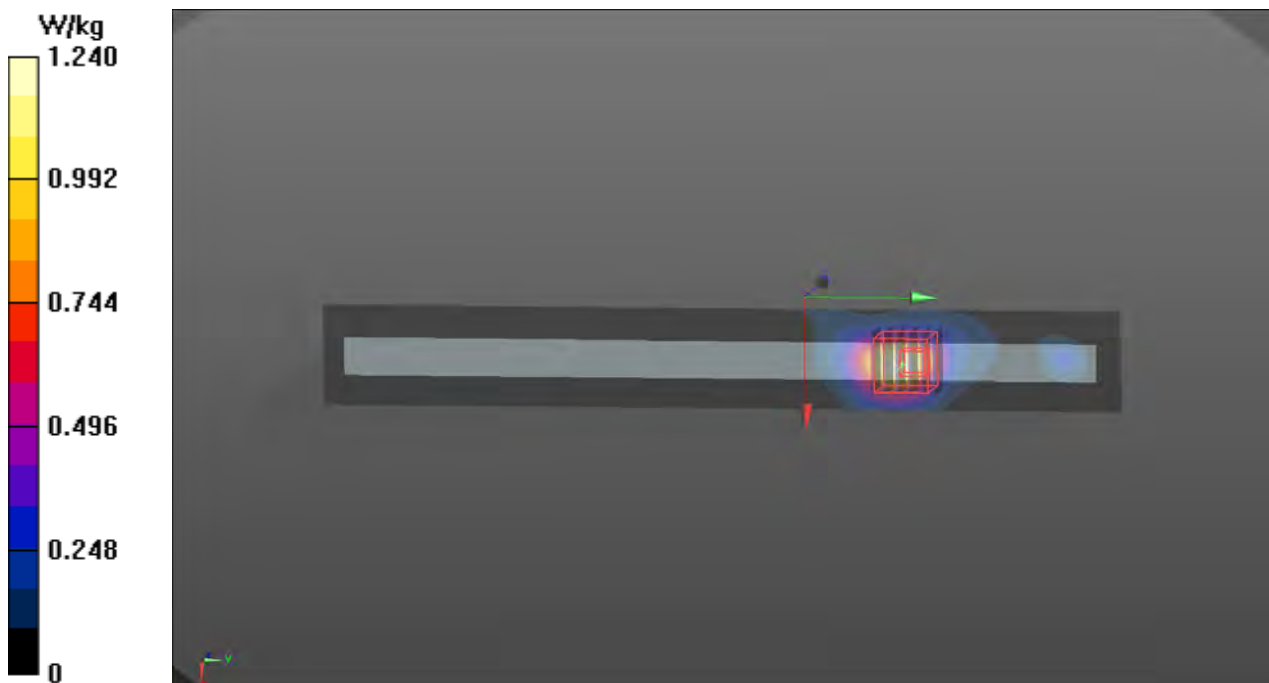

**P21 802.11a\_Rear Face\_0cm\_Ch64\_Ant B\_ACON****DUT: 512732-02\_ACON**

Communication System: WLAN\_5G; Frequency: 5320 MHz; Duty Cycle: 1:1

Medium: B5G\_150720 Medium parameters used:  $f = 5320$  MHz;  $\sigma = 5.524$  S/m;  $\epsilon_r = 48.523$ ;  $\rho = 1000$  kg/m<sup>3</sup>**Ambient Temperature : 23.2 °C; Liquid Temperature : 22.5 °C**

DASY5 Configuration:

- Probe: EX3DV4 - SN3976; ConvF(4.52, 4.52, 4.52); Calibrated: 2015/2/26;
- Sensor-Surface: 2mm (Mechanical Surface Detection)
- Electronics: DAE4 Sn1424; Calibrated: 2015/2/20
- Phantom: ELI v5.0; Type: QDOVA002AA; Serial: TP:1238
- Measurement SW: DASY52, Version 52.8 (8); SEMCAD X Version 14.6.10 (7331)

**Ch64/Area Scan (241x321x1):** Interpolated grid: dx=1.000 mm, dy=1.000 mm

Maximum value of SAR (interpolated) = 0.346 W/kg

**Ch64/Zoom Scan (6x6x12)/Cube 0:** Measurement grid: dx=5mm, dy=5mm, dz=2mm

Reference Value = 8.502 V/m; Power Drift = -0.10 dB

Peak SAR (extrapolated) = 0.758 W/kg

**SAR(1 g) = 0.180 W/kg; SAR(10 g) = 0.060 W/kg**

Maximum value of SAR (measured) = 0.340 W/kg

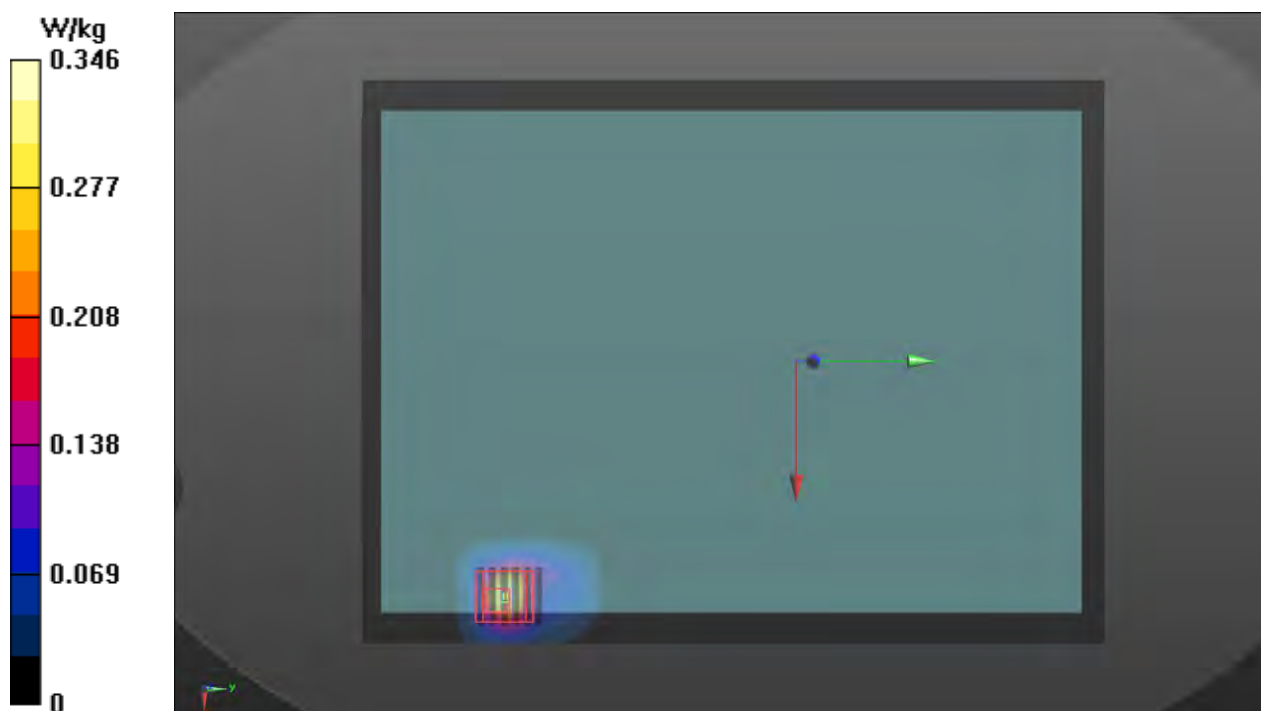

## P22 802.11a\_Edge3\_0cm\_Ch64\_Ant B\_ACON

**DUT: 512732-02\_ACON**

Communication System: WLAN\_5G; Frequency: 5320 MHz; Duty Cycle: 1:1  
Medium: B5G\_150720 Medium parameters used:  $f = 5320$  MHz;  $\sigma = 5.524$  S/m;  $\epsilon_r = 48.523$ ;  $\rho = 1000$  kg/m<sup>3</sup>

**Ambient Temperature : 23.4 °C; Liquid Temperature : 22.5 °C**

DASY5 Configuration:

- Probe: EX3DV4 - SN3976; ConvF(4.52, 4.52, 4.52); Calibrated: 2015/2/26;
- Sensor-Surface: 2mm (Mechanical Surface Detection)
- Electronics: DAE4 Sn1424; Calibrated: 2015/2/20
- Phantom: ELI v5.0; Type: QDOVA002AA; Serial: TP:1238
- Measurement SW: DASY52, Version 52.8 (8); SEMCAD X Version 14.6.10 (7331)

**Ch64/Area Scan (41x321x1):** Interpolated grid: dx=1.000 mm, dy=1.000 mm

Maximum value of SAR (interpolated) = 0.659 W/kg

**Ch64/Zoom Scan (6x6x12)/Cube 0:** Measurement grid: dx=5mm, dy=5mm, dz=2mm

Reference Value = 11.82 V/m; Power Drift = -0.05 dB

Peak SAR (extrapolated) = 1.59 W/kg

**SAR(1 g) = 0.404 W/kg; SAR(10 g) = 0.129 W/kg**

Maximum value of SAR (measured) = 0.763 W/kg

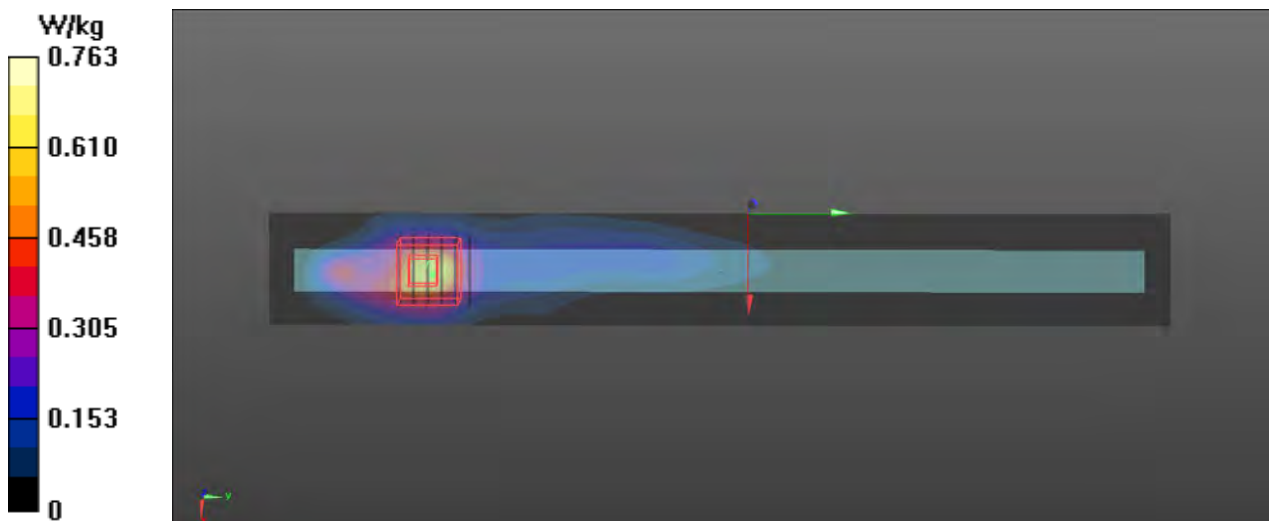

## P23 802.11a\_Rear Face\_0cm\_Ch64\_Ant B\_Inpaq

### DUT: 512732-02\_Inpaq

Communication System: WLAN\_5G; Frequency: 5320 MHz; Duty Cycle: 1:1  
Medium: B5G\_150717 Medium parameters used:  $f = 5320$  MHz;  $\sigma = 5.526$  S/m;  $\epsilon_r = 48.524$ ;  $\rho = 1000$  kg/m<sup>3</sup>

**Ambient Temperature : 23.2 °C; Liquid Temperature : 22.6 °C**

#### DASY5 Configuration:

- Probe: EX3DV4 - SN3976; ConvF(4.52, 4.52, 4.52); Calibrated: 2015/2/26;
- Sensor-Surface: 2mm (Mechanical Surface Detection)
- Electronics: DAE4 Sn1424; Calibrated: 2015/2/20
- Phantom: ELI v5.0; Type: QDOVA002AA; Serial: TP:1238
- Measurement SW: DASY52, Version 52.8 (8); SEMCAD X Version 14.6.10 (7331)

**Ch64/Area Scan (241x321x1):** Interpolated grid: dx=1.000 mm, dy=1.000 mm  
Maximum value of SAR (interpolated) = 0.372 W/kg

**Ch64/Zoom Scan (6x6x12)/Cube 0:** Measurement grid: dx=5mm, dy=5mm, dz=2mm

Reference Value = 8.869 V/m; Power Drift = -0.12 dB

Peak SAR (extrapolated) = 1.03 W/kg

**SAR(1 g) = 0.289 W/kg; SAR(10 g) = 0.132 W/kg**

Maximum value of SAR (measured) = 0.505 W/kg





## P24 802.11a\_Edge3\_0cm\_Ch64\_Ant B\_Inpaq

### DUT: 512732-02\_Inpaq

Communication System: WLAN\_5G; Frequency: 5320 MHz; Duty Cycle: 1:1

Medium: B5G\_150717 Medium parameters used:  $f = 5320$  MHz;  $\sigma = 5.526$  S/m;  $\epsilon_r = 48.524$ ;  $\rho = 1000$  kg/m<sup>3</sup>

**Ambient Temperature : 23.2 °C; Liquid Temperature : 22.6 °C**

#### DASY5 Configuration:

- Probe: EX3DV4 - SN3976; ConvF(4.52, 4.52, 4.52); Calibrated: 2015/2/26;
- Sensor-Surface: 2mm (Mechanical Surface Detection)
- Electronics: DAE4 Sn1424; Calibrated: 2015/2/20
- Phantom: ELI v5.0; Type: QDOVA002AA; Serial: TP:1238
- Measurement SW: DASY52, Version 52.8 (8); SEMCAD X Version 14.6.10 (7331)

**Ch64/Area Scan (41x321x1):** Interpolated grid: dx=1.000 mm, dy=1.000 mm

Maximum value of SAR (interpolated) = 0.631 W/kg

**Ch64/Zoom Scan (6x6x12)/Cube 0:** Measurement grid: dx=5mm, dy=5mm, dz=2mm

Reference Value = 10.44 V/m; Power Drift = -0.02 dB

Peak SAR (extrapolated) = 2.66 W/kg

**SAR(1 g) = 0.538 W/kg; SAR(10 g) = 0.140 W/kg**

Maximum value of SAR (measured) = 1.11 W/kg

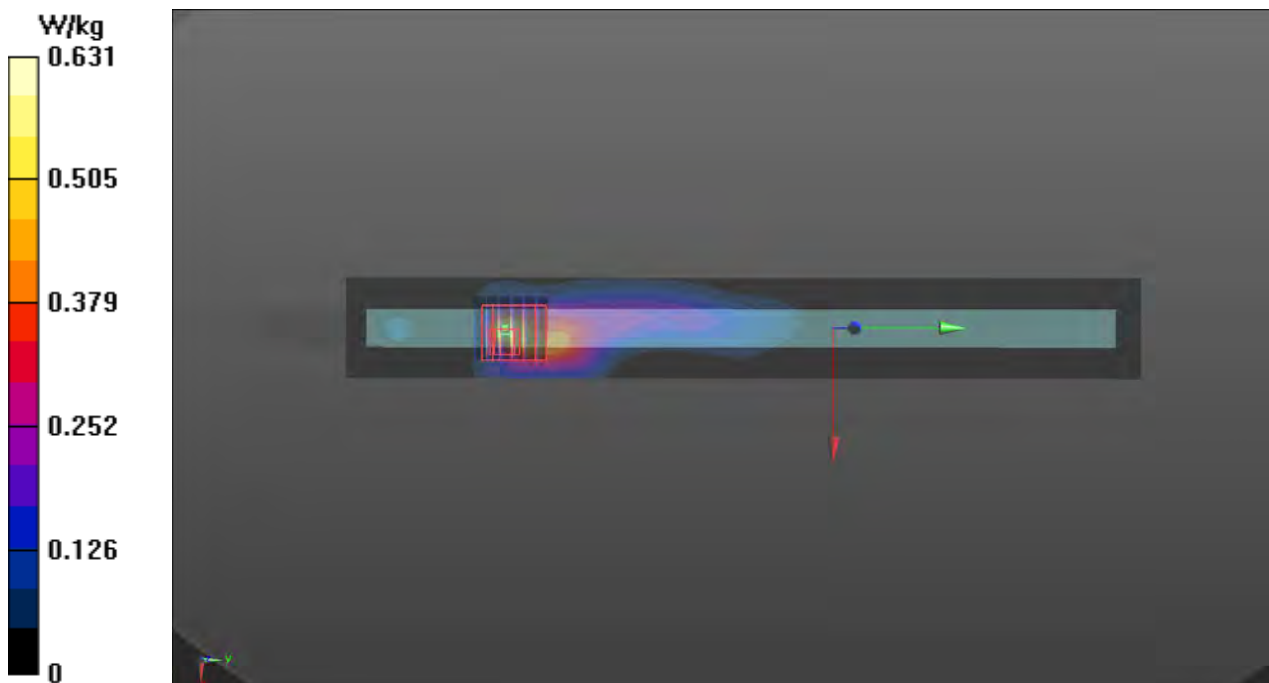

## P25 802.11a\_Rear Face\_0cm\_Ch112\_Ant A\_ACON

**DUT: 512732-02\_ACON**

Communication System: WLAN\_5G; Frequency: 5560 MHz; Duty Cycle: 1:1  
Medium: B5G\_150721 Medium parameters used:  $f = 5560$  MHz;  $\sigma = 5.839$  S/m;  $\epsilon_r = 48.12$ ;  $\rho = 1000$  kg/m<sup>3</sup>

**Ambient Temperature : 23.3 °C; Liquid Temperature : 22.4 °C**

DASY5 Configuration:

- Probe: EX3DV4 - SN3976; ConvF(3.9, 3.9, 3.9); Calibrated: 2015/2/26;
- Sensor-Surface: 2mm (Mechanical Surface Detection)
- Electronics: DAE4 Sn1424; Calibrated: 2015/2/20
- Phantom: ELI v5.0; Type: QDOVA002AA; Serial: TP:1238
- Measurement SW: DASY52, Version 52.8 (8); SEMCAD X Version 14.6.10 (7331)

**Ch112/Area Scan (241x321x1):** Interpolated grid: dx=1.000 mm, dy=1.000 mm  
Maximum value of SAR (interpolated) = 0.531 W/kg

**Ch112/Zoom Scan (6x6x12)/Cube 0:** Measurement grid: dx=5mm, dy=5mm, dz=2mm

Reference Value = 10.29 V/m; Power Drift = -0.07 dB

Peak SAR (extrapolated) = 1.14 W/kg

**SAR(1 g) = 0.277 W/kg; SAR(10 g) = 0.098 W/kg**

Maximum value of SAR (measured) = 0.503 W/kg

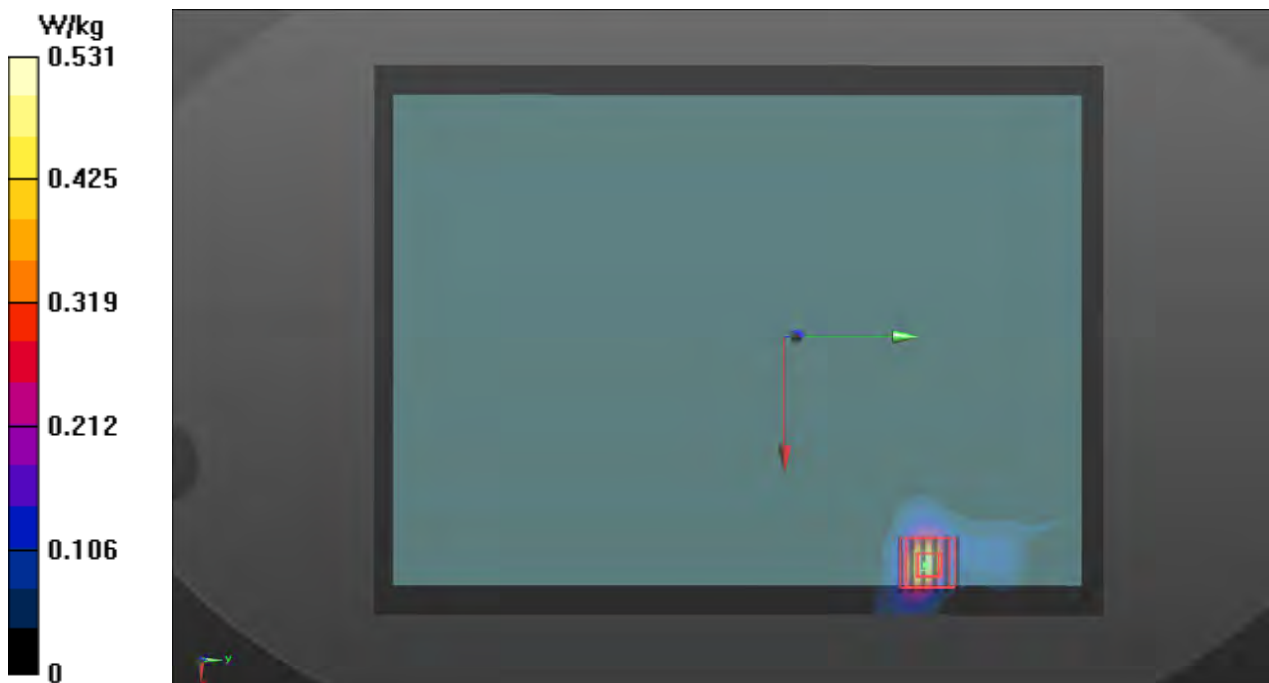

**P26 802.11a\_Edge3\_0cm\_Ch112\_Ant A\_ACON****DUT: 512732-02\_ACON**

Communication System: WLAN\_5G; Frequency: 5560 MHz; Duty Cycle: 1:1  
Medium: B5G\_150721 Medium parameters used:  $f = 5560$  MHz;  $\sigma = 5.839$  S/m;  $\epsilon_r = 48.12$ ;  $\rho = 1000$  kg/m<sup>3</sup>

**Ambient Temperature : 23.3 °C; Liquid Temperature : 22.4 °C**

**DASY5 Configuration:**

- Probe: EX3DV4 - SN3976; ConvF(3.9, 3.9, 3.9); Calibrated: 2015/2/26;
- Sensor-Surface: 2mm (Mechanical Surface Detection)
- Electronics: DAE4 Sn1424; Calibrated: 2015/2/20
- Phantom: ELI v5.0; Type: QDOVA002AA; Serial: TP:1238
- Measurement SW: DASY52, Version 52.8 (8); SEMCAD X Version 14.6.10 (7331)

**Ch112/Area Scan (41x321x1):** Interpolated grid: dx=1.000 mm, dy=1.000 mm

Maximum value of SAR (interpolated) = 0.676 W/kg

**Ch112/Zoom Scan (6x6x12)/Cube 0:** Measurement grid: dx=5mm, dy=5mm, dz=2mm

Reference Value = 10.95 V/m; Power Drift = -0.03 dB

Peak SAR (extrapolated) = 1.55 W/kg

**SAR(1 g) = 0.356 W/kg; SAR(10 g) = 0.125 W/kg**

Maximum value of SAR (measured) = 0.717 W/kg

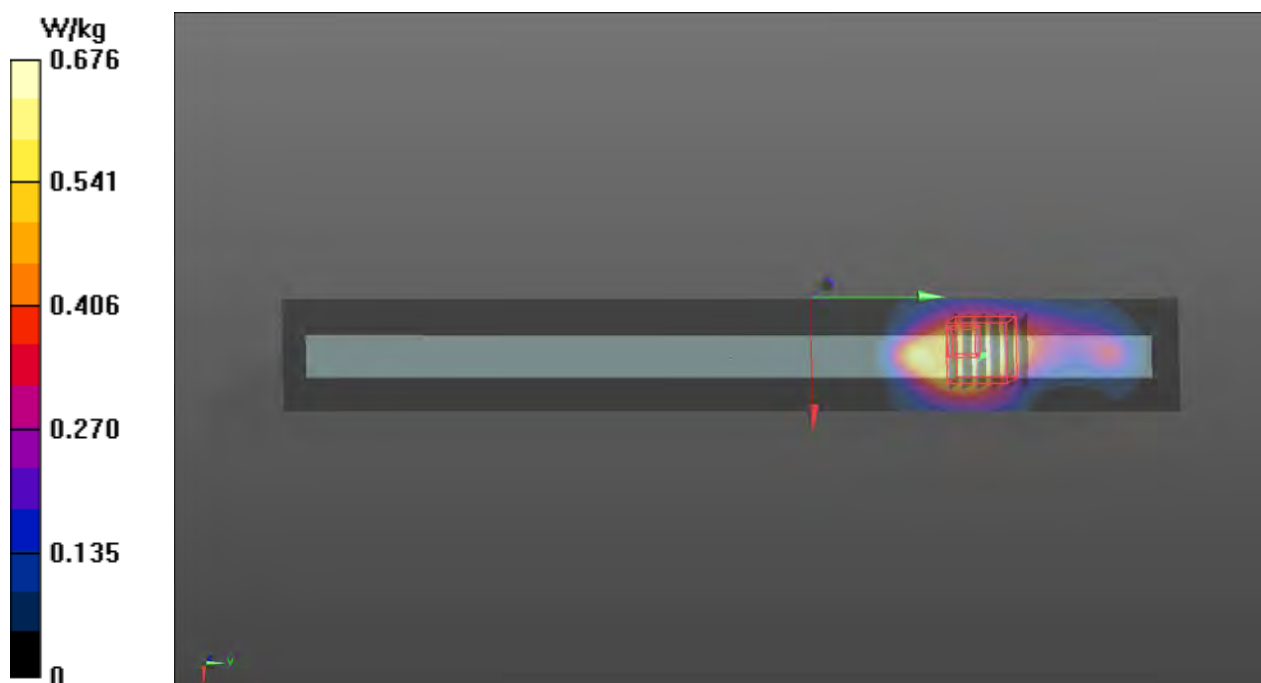

## P27 802.11a\_Rear Face\_0cm\_Ch112\_Ant A\_Inpaq

### DUT: 512732-02\_Inpaq

Communication System: WLAN\_5G; Frequency: 5560 MHz; Duty Cycle: 1:1

Medium: B5G\_150717 Medium parameters used:  $f = 5560$  MHz;  $\sigma = 5.841$  S/m;  $\epsilon_r = 48.118$ ;  $\rho = 1000$  kg/m<sup>3</sup>

**Ambient Temperature : 23.2 °C; Liquid Temperature : 22.6 °C**

#### DASY5 Configuration:

- Probe: EX3DV4 - SN3976; ConvF(3.9, 3.9, 3.9); Calibrated: 2015/2/26;
- Sensor-Surface: 2mm (Mechanical Surface Detection)
- Electronics: DAE4 Sn1424; Calibrated: 2015/2/20
- Phantom: ELI v5.0; Type: QDOVA002AA; Serial: TP:1238
- Measurement SW: DASY52, Version 52.8 (8); SEMCAD X Version 14.6.10 (7331)

**Ch112/Area Scan (241x321x1):** Interpolated grid: dx=1.000 mm, dy=1.000 mm

Maximum value of SAR (interpolated) = 0.687 W/kg

**Ch112/Zoom Scan (6x6x12)/Cube 0:** Measurement grid: dx=5mm, dy=5mm, dz=2mm

Reference Value = 9.143 V/m; Power Drift = -0.02 dB

Peak SAR (extrapolated) = 1.35 W/kg

**SAR(1 g) = 0.304 W/kg; SAR(10 g) = 0.102 W/kg**

Maximum value of SAR (measured) = 0.620 W/kg

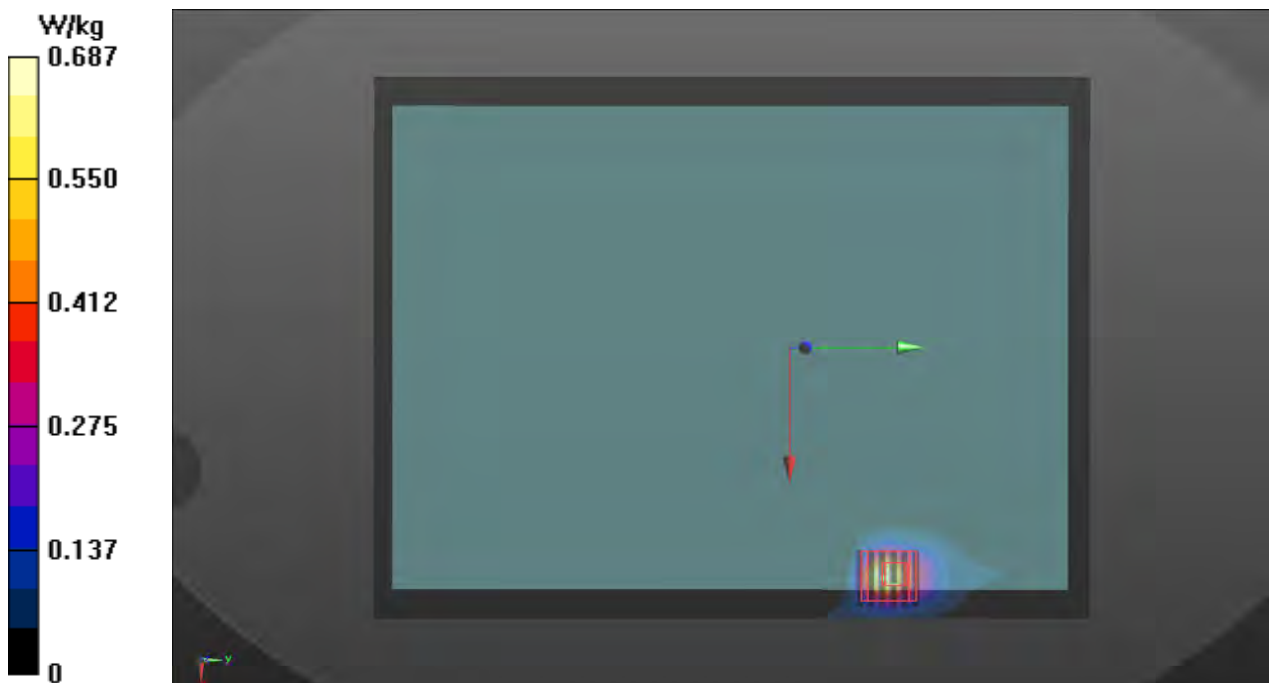

## P28 802.11a\_Edge3\_0cm\_Ch112\_Ant A\_Inpaq

### DUT: 512732-02\_Inpaq

Communication System: WLAN\_5G; Frequency: 5560 MHz; Duty Cycle: 1:1

Medium: B5G\_150717 Medium parameters used:  $f = 5560$  MHz;  $\sigma = 5.841$  S/m;  $\epsilon_r = 48.118$ ;  $\rho = 1000$  kg/m<sup>3</sup>

**Ambient Temperature : 23.2 °C; Liquid Temperature : 22.6 °C**

#### DASY5 Configuration:

- Probe: EX3DV4 - SN3976; ConvF(3.9, 3.9, 3.9); Calibrated: 2015/2/26;
- Sensor-Surface: 2mm (Mechanical Surface Detection)
- Electronics: DAE4 Sn1424; Calibrated: 2015/2/20
- Phantom: ELI v5.0; Type: QDOVA002AA; Serial: TP:1238
- Measurement SW: DASY52, Version 52.8 (8); SEMCAD X Version 14.6.10 (7331)

**Ch112/Area Scan (41x321x1):** Interpolated grid: dx=1.000 mm, dy=1.000 mm

Maximum value of SAR (interpolated) = 1.47 W/kg

**Ch112/Zoom Scan (6x6x12)/Cube 0:** Measurement grid: dx=5mm, dy=5mm, dz=2mm

Reference Value = 16.06 V/m; Power Drift = -0.07 dB

Peak SAR (extrapolated) = 2.81 W/kg

**SAR(1 g) = 0.653 W/kg; SAR(10 g) = 0.238 W/kg**

Maximum value of SAR (measured) = 1.28 W/kg

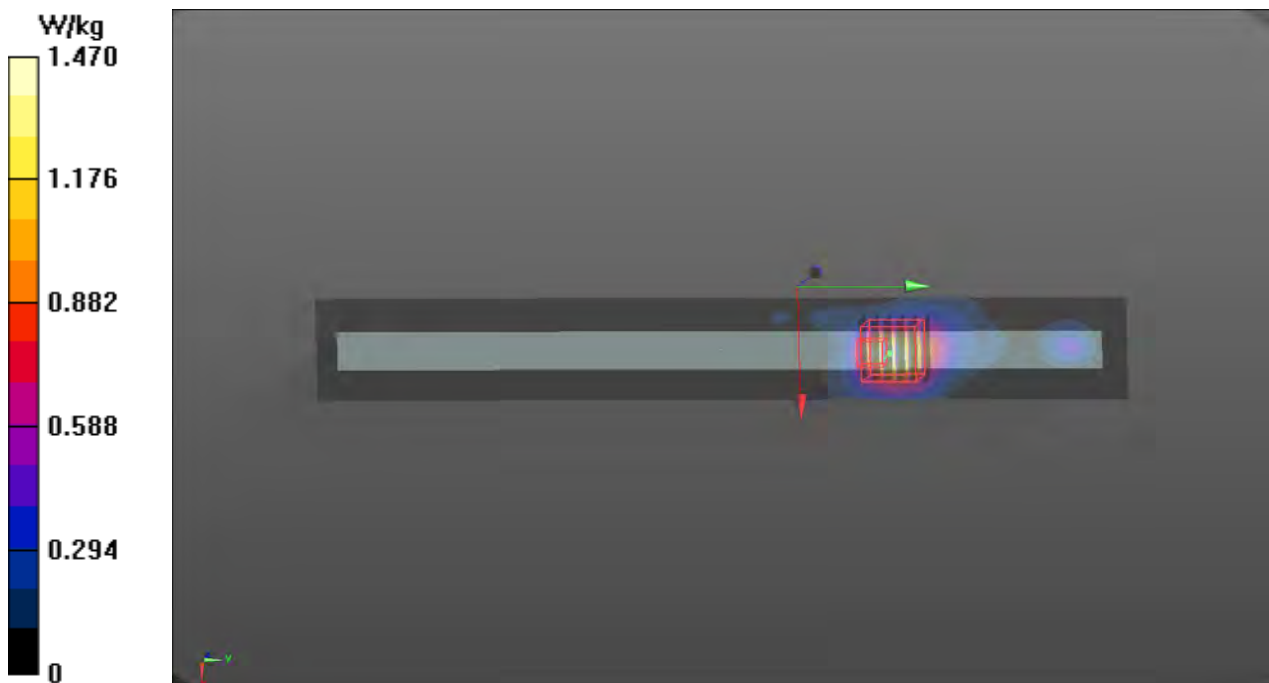

## P29 802.11a\_Rear Face\_0cm\_Ch132\_Ant B\_ACON

**DUT: 512732-02\_ACON**

Communication System: WLAN\_5G; Frequency: 5660 MHz; Duty Cycle: 1:1

Medium: B5G\_150721 Medium parameters used:  $f = 5660$  MHz;  $\sigma = 5.979$  S/m;  $\epsilon_r = 47.962$ ;  $\rho = 1000$  kg/m<sup>3</sup>

**Ambient Temperature : 23.3 °C; Liquid Temperature : 22.4 °C**

DASY5 Configuration:

- Probe: EX3DV4 - SN3976; ConvF(3.9, 3.9, 3.9); Calibrated: 2015/2/26;
- Sensor-Surface: 2mm (Mechanical Surface Detection)
- Electronics: DAE4 Sn1424; Calibrated: 2015/2/20
- Phantom: ELI v5.0; Type: QDOVA002AA; Serial: TP:1238
- Measurement SW: DASY52, Version 52.8 (8); SEMCAD X Version 14.6.10 (7331)

**Ch132/Area Scan (241x321x1):** Interpolated grid: dx=1.000 mm, dy=1.000 mm

Maximum value of SAR (interpolated) = 0.382 W/kg

**Ch132/Zoom Scan (6x6x12)/Cube 0:** Measurement grid: dx=5mm, dy=5mm, dz=2mm

Reference Value = 8.734 V/m; Power Drift = -0.12 dB

Peak SAR (extrapolated) = 0.937 W/kg

**SAR(1 g) = 0.225 W/kg; SAR(10 g) = 0.074 W/kg**

Maximum value of SAR (measured) = 0.452 W/kg

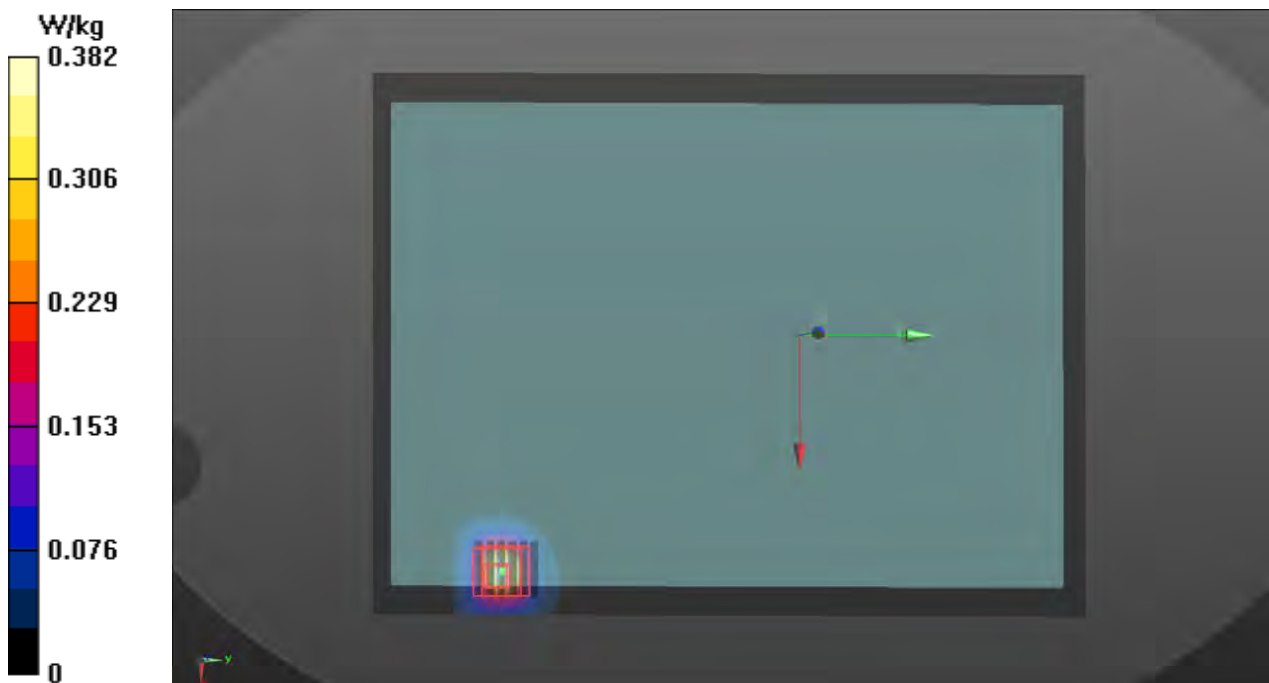

### P30 802.11a\_Edge3\_0cm\_Ch132\_Ant B\_ACON

**DUT: 512732-02\_ACON**

Communication System: WLAN\_5G; Frequency: 5660 MHz; Duty Cycle: 1:1  
Medium: B5G\_150721 Medium parameters used:  $f = 5660$  MHz;  $\sigma = 5.979$  S/m;  $\epsilon_r = 47.962$ ;  $\rho = 1000$  kg/m<sup>3</sup>

**Ambient Temperature : 23.3 °C; Liquid Temperature : 22.4 °C**

DASY5 Configuration:

- Probe: EX3DV4 - SN3976; ConvF(3.9, 3.9, 3.9); Calibrated: 2015/2/26;
- Sensor-Surface: 2mm (Mechanical Surface Detection)
- Electronics: DAE4 Sn1424; Calibrated: 2015/2/20
- Phantom: ELI v5.0; Type: QDOVA002AA; Serial: TP:1238
- Measurement SW: DASY52, Version 52.8 (8); SEMCAD X Version 14.6.10 (7331)

**Ch132/Area Scan (41x321x1):** Interpolated grid: dx=1.000 mm, dy=1.000 mm  
Maximum value of SAR (interpolated) = 0.518 W/kg

**Ch132/Zoom Scan (6x6x12)/Cube 0:** Measurement grid: dx=5mm, dy=5mm, dz=2mm

Reference Value = 9.440 V/m; Power Drift = 0.01 dB

Peak SAR (extrapolated) = 1.28 W/kg

**SAR(1 g) = 0.303 W/kg; SAR(10 g) = 0.101 W/kg**

Maximum value of SAR (measured) = 0.613 W/kg

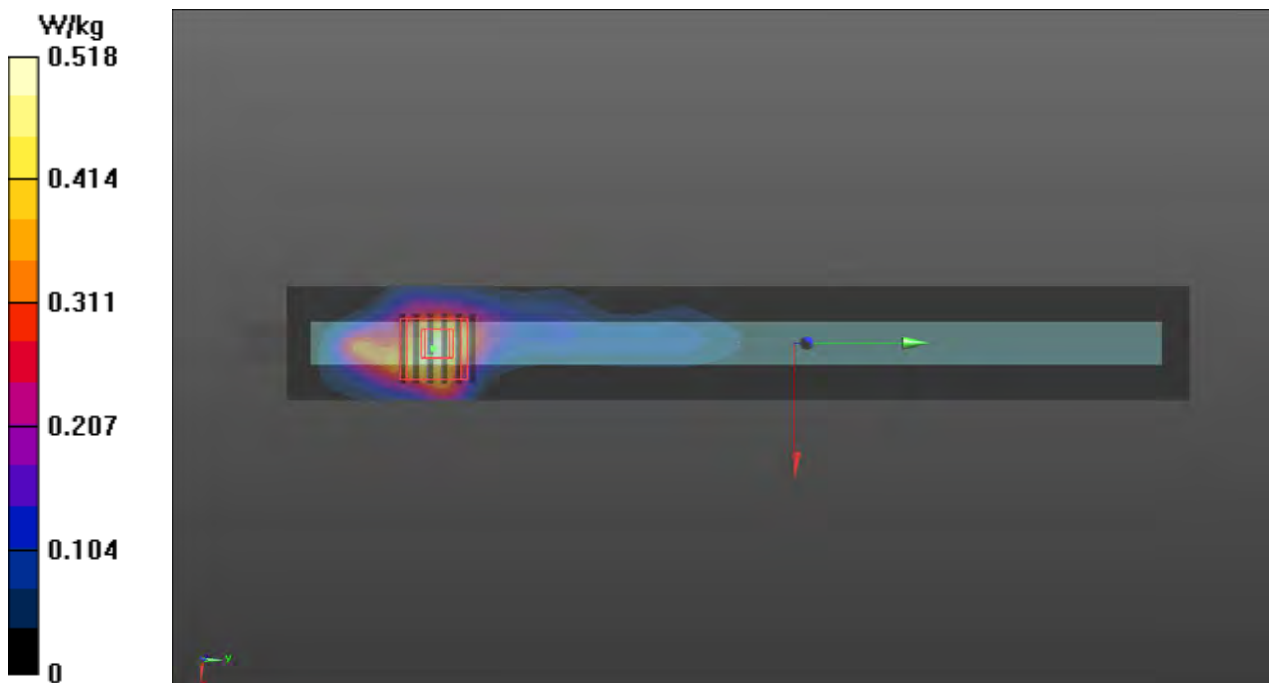

### P31 802.11a\_Rear Face\_0cm\_Ch132\_Ant B\_Inpaq

#### DUT: 512732-02\_Inpaq

Communication System: WLAN\_5G; Frequency: 5660 MHz; Duty Cycle: 1:1  
Medium: B5G\_150717 Medium parameters used:  $f = 5660$  MHz;  $\sigma = 5.981$  S/m;  $\epsilon_r = 47.962$ ;  $\rho = 1000$  kg/m<sup>3</sup>

**Ambient Temperature : 23.2 °C; Liquid Temperature : 22.6 °C**

#### DASY5 Configuration:

- Probe: EX3DV4 - SN3976; ConvF(3.9, 3.9, 3.9); Calibrated: 2015/2/26;
- Sensor-Surface: 2mm (Mechanical Surface Detection)
- Electronics: DAE4 Sn1424; Calibrated: 2015/2/20
- Phantom: ELI v5.0; Type: QDOVA002AA; Serial: TP:1238
- Measurement SW: DASY52, Version 52.8 (8); SEMCAD X Version 14.6.10 (7331)

**Ch132/Area Scan (241x321x1):** Interpolated grid: dx=1.000 mm, dy=1.000 mm  
Maximum value of SAR (interpolated) = 0.527 W/kg

**Ch132/Zoom Scan (6x6x12)/Cube 0:** Measurement grid: dx=5mm, dy=5mm, dz=2mm  
Reference Value = 10.28 V/m; Power Drift = -0.05 dB  
Peak SAR (extrapolated) = 1.36 W/kg  
**SAR(1 g) = 0.360 W/kg; SAR(10 g) = 0.160 W/kg**  
Maximum value of SAR (measured) = 0.637 W/kg

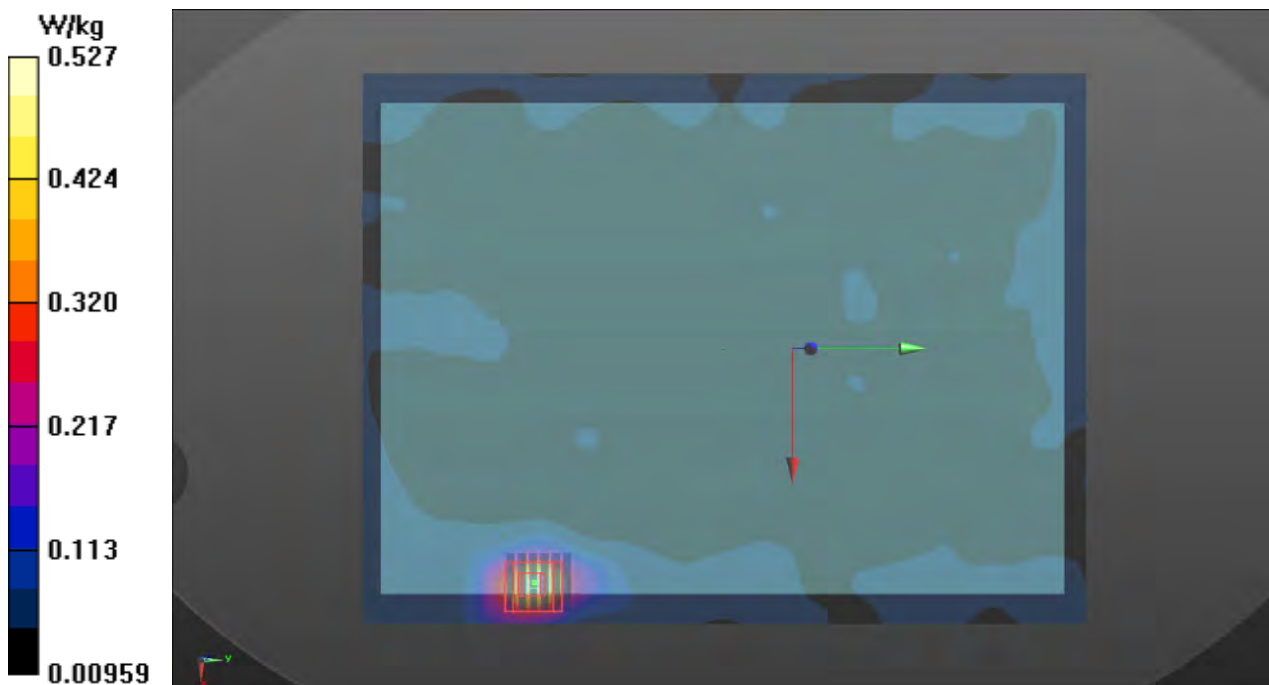



### P32 802.11a\_Edge3\_0cm\_Ch132\_Ant B\_Inpaq

#### DUT: 512732-02\_Inpaq

Communication System: WLAN\_5G; Frequency: 5660 MHz; Duty Cycle: 1:1  
Medium: B5G\_150717 Medium parameters used:  $f = 5660$  MHz;  $\sigma = 5.981$  S/m;  $\epsilon_r = 47.962$ ;  $\rho = 1000$  kg/m<sup>3</sup>

**Ambient Temperature : 23.2 °C; Liquid Temperature : 22.6 °C**

#### DASY5 Configuration:

- Probe: EX3DV4 - SN3976; ConvF(3.9, 3.9, 3.9); Calibrated: 2015/2/26;
- Sensor-Surface: 2mm (Mechanical Surface Detection)
- Electronics: DAE4 Sn1424; Calibrated: 2015/2/20
- Phantom: ELI v5.0; Type: QDOVA002AA; Serial: TP:1238
- Measurement SW: DASY52, Version 52.8 (8); SEMCAD X Version 14.6.10 (7331)

**Ch132/Area Scan (41x321x1):** Interpolated grid: dx=1.000 mm, dy=1.000 mm  
Maximum value of SAR (interpolated) = 0.785 W/kg

**Ch132/Zoom Scan (6x6x12)/Cube 0:** Measurement grid: dx=5mm, dy=5mm, dz=2mm

Reference Value = 11.37 V/m; Power Drift = -0.09 dB

Peak SAR (extrapolated) = 3.38 W/kg

**SAR(1 g) = 0.670 W/kg; SAR(10 g) = 0.193 W/kg**

Maximum value of SAR (measured) = 1.49 W/kg

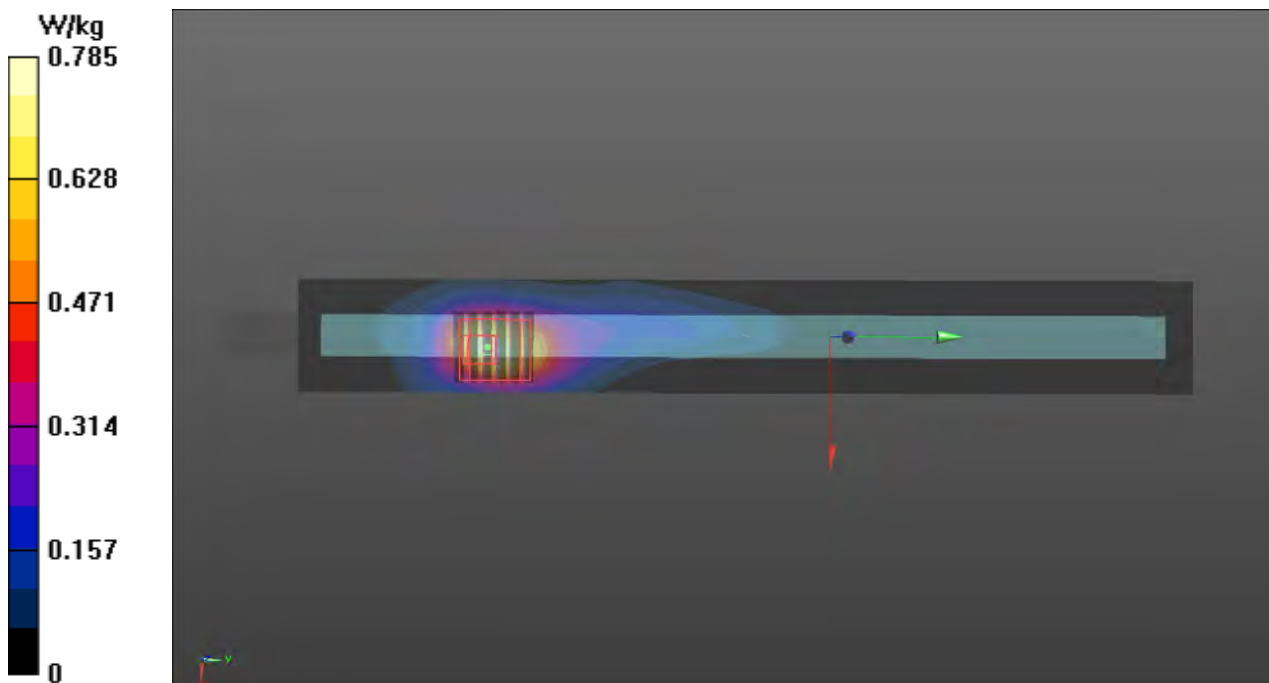

### P33 802.11a\_Rear Face\_0cm\_Ch165\_Ant A\_ACON

**DUT: 512732-02\_ACON**

Communication System: WLAN\_5G; Frequency: 5825 MHz; Duty Cycle: 1:1  
Medium: B5G\_150721 Medium parameters used:  $f = 5825$  MHz;  $\sigma = 6.212$  S/m;  $\epsilon_r = 47.691$ ;  $\rho = 1000$  kg/m<sup>3</sup>

**Ambient Temperature : 23.3 °C; Liquid Temperature : 22.4 °C**

DASY5 Configuration:

- Probe: EX3DV4 - SN3976; ConvF(4.23, 4.23, 4.23); Calibrated: 2015/2/26;
- Sensor-Surface: 2mm (Mechanical Surface Detection)
- Electronics: DAE4 Sn1424; Calibrated: 2015/2/20
- Phantom: ELI v5.0; Type: QDOVA002AA; Serial: TP:1238
- Measurement SW: DASY52, Version 52.8 (8); SEMCAD X Version 14.6.10 (7331)

**Ch165/Area Scan (241x161x1):** Interpolated grid: dx=1.000 mm, dy=1.000 mm  
Maximum value of SAR (interpolated) = 0.565 W/kg

**Ch165/Zoom Scan (6x6x12)/Cube 0:** Measurement grid: dx=5mm, dy=5mm, dz=2mm

Reference Value = 10.50 V/m; Power Drift = 0.03 dB

Peak SAR (extrapolated) = 1.20 W/kg

**SAR(1 g) = 0.285 W/kg; SAR(10 g) = 0.105 W/kg**

Maximum value of SAR (measured) = 0.555 W/kg

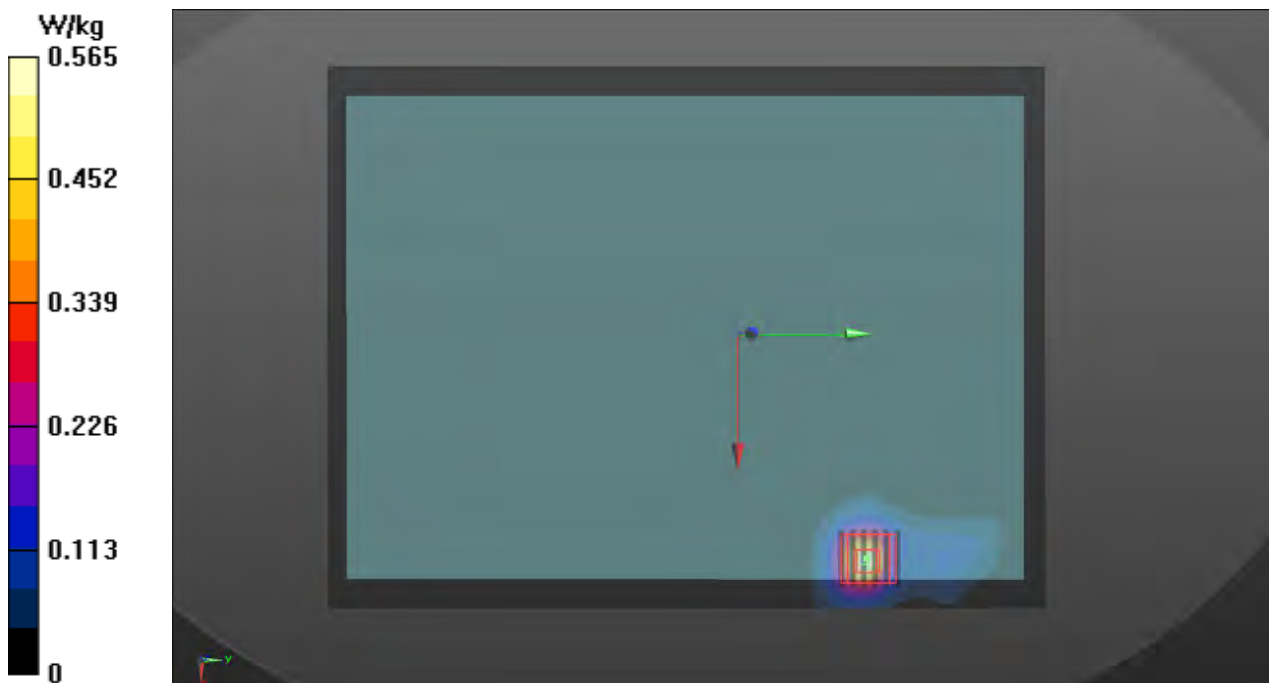

### P34 802.11a\_Edge3\_0cm\_Ch165\_Ant A\_ACON

**DUT: 512732-02\_ACON**

Communication System: WLAN\_5G; Frequency: 5825 MHz; Duty Cycle: 1:1

Medium: B5G\_150721 Medium parameters used:  $f = 5825$  MHz;  $\sigma = 6.212$  S/m;  $\epsilon_r = 47.691$ ;  $\rho = 1000$  kg/m<sup>3</sup>

**Ambient Temperature : 23.3 °C; Liquid Temperature : 22.4 °C**

DASY5 Configuration:

- Probe: EX3DV4 - SN3976; ConvF(4.23, 4.23, 4.23); Calibrated: 2015/2/26;
- Sensor-Surface: 2mm (Mechanical Surface Detection)
- Electronics: DAE4 Sn1424; Calibrated: 2015/2/20
- Phantom: ELI v5.0; Type: QDOVA002AA; Serial: TP:1238
- Measurement SW: DASY52, Version 52.8 (8); SEMCAD X Version 14.6.10 (7331)

**Ch165/Area Scan (41x321x1):** Interpolated grid: dx=1.000 mm, dy=1.000 mm

Maximum value of SAR (interpolated) = 0.741 W/kg

**Ch165/Zoom Scan (6x6x12)/Cube 0:** Measurement grid: dx=5mm, dy=5mm, dz=2mm

Reference Value = 11.67 V/m; Power Drift = -0.10 dB

Peak SAR (extrapolated) = 2.74 W/kg

**SAR(1 g) = 0.590 W/kg; SAR(10 g) = 0.187 W/kg**

Maximum value of SAR (measured) = 1.24 W/kg

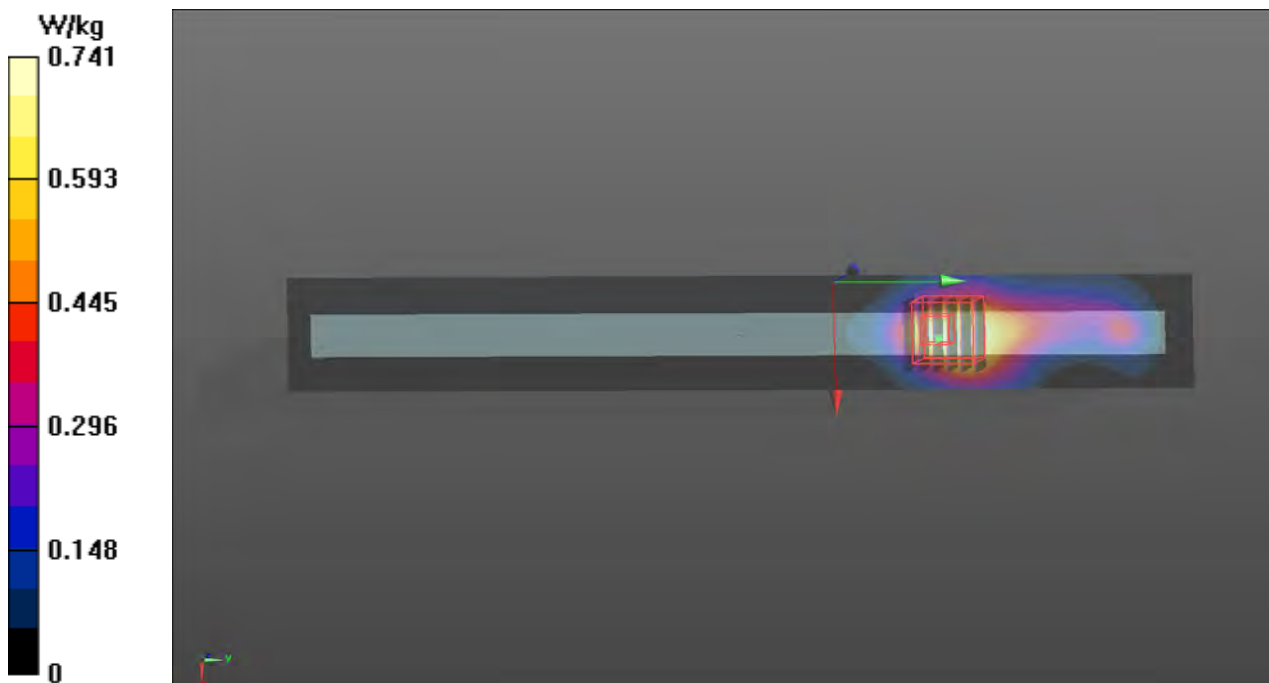

### P35 802.11a\_Rear Face\_0cm\_Ch165\_Ant A\_Inpaq

**DUT: 512732-02\_Inpaq**

Communication System: WLAN\_5G; Frequency: 5825 MHz; Duty Cycle: 1:1  
Medium: B5G\_150717 Medium parameters used:  $f = 5825 \text{ MHz}$ ;  $\sigma = 6.213 \text{ S/m}$ ;  $\epsilon_r = 47.69$ ;  $\rho = 1000 \text{ kg/m}^3$

**Ambient Temperature : 23.2 °C; Liquid Temperature : 22.6 °C**

DASY5 Configuration:

- Probe: EX3DV4 - SN3976; ConvF(4.23, 4.23, 4.23); Calibrated: 2015/2/26;
- Sensor-Surface: 2mm (Mechanical Surface Detection)
- Electronics: DAE4 Sn1424; Calibrated: 2015/2/20
- Phantom: ELI v5.0; Type: QDOVA002AA; Serial: TP:1238
- Measurement SW: DASY52, Version 52.8 (8); SEMCAD X Version 14.6.10 (7331)

**Ch165/Area Scan (241x321x1):** Interpolated grid:  $dx=1.000 \text{ mm}$ ,  $dy=1.000 \text{ mm}$   
Maximum value of SAR (interpolated) = 0.700 W/kg

**Ch165/Zoom Scan (6x6x12)/Cube 0:** Measurement grid:  $dx=5\text{mm}$ ,  $dy=5\text{mm}$ ,  $dz=2\text{mm}$

Reference Value = 11.19 V/m; Power Drift = -0.03 dB

Peak SAR (extrapolated) = 1.79 W/kg

**SAR(1 g) = 0.385 W/kg; SAR(10 g) = 0.132 W/kg**

Maximum value of SAR (measured) = 0.824 W/kg

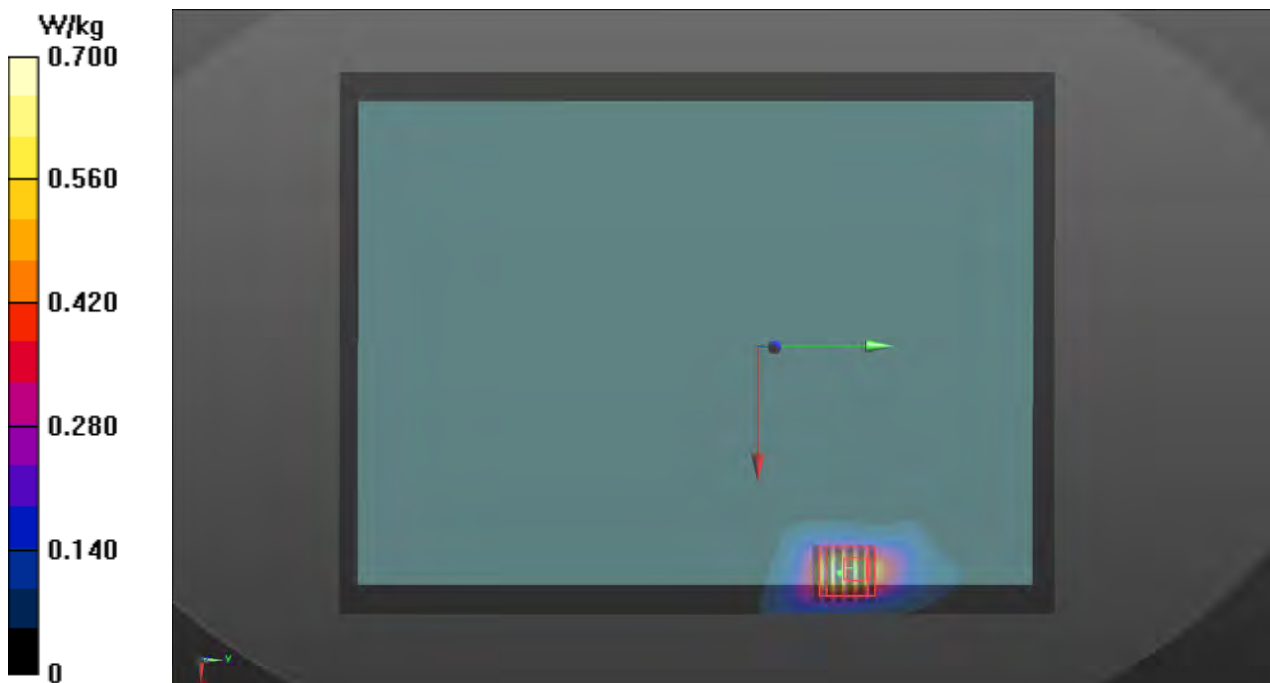

### P36 802.11a\_Edge3\_0cm\_Ch165\_Ant A\_Inpaq

#### DUT: 512732-02\_Inpaq

Communication System: WLAN\_5G; Frequency: 5825 MHz; Duty Cycle: 1:1  
Medium: B5G\_150717 Medium parameters used:  $f = 5825$  MHz;  $\sigma = 6.213$  S/m;  $\epsilon_r = 47.69$ ;  $\rho = 1000$  kg/m<sup>3</sup>

**Ambient Temperature : 23.2 °C; Liquid Temperature : 22.6 °C**

#### DASY5 Configuration:

- Probe: EX3DV4 - SN3976; ConvF(4.23, 4.23, 4.23); Calibrated: 2015/2/26;
- Sensor-Surface: 2mm (Mechanical Surface Detection)
- Electronics: DAE4 Sn1424; Calibrated: 2015/2/20
- Phantom: ELI v5.0; Type: QDOVA002AA; Serial: TP:1238
- Measurement SW: DASY52, Version 52.8 (8); SEMCAD X Version 14.6.10 (7331)

**Ch165/Area Scan (41x321x1):** Interpolated grid: dx=1.000 mm, dy=1.000 mm  
Maximum value of SAR (interpolated) = 1.16 W/kg

**Ch165/Zoom Scan (6x6x12)/Cube 0:** Measurement grid: dx=5mm, dy=5mm, dz=2mm

Reference Value = 14.64 V/m; Power Drift = -0.05 dB

Peak SAR (extrapolated) = 2.66 W/kg

**SAR(1 g) = 0.591 W/kg; SAR(10 g) = 0.200 W/kg**

Maximum value of SAR (measured) = 1.19 W/kg

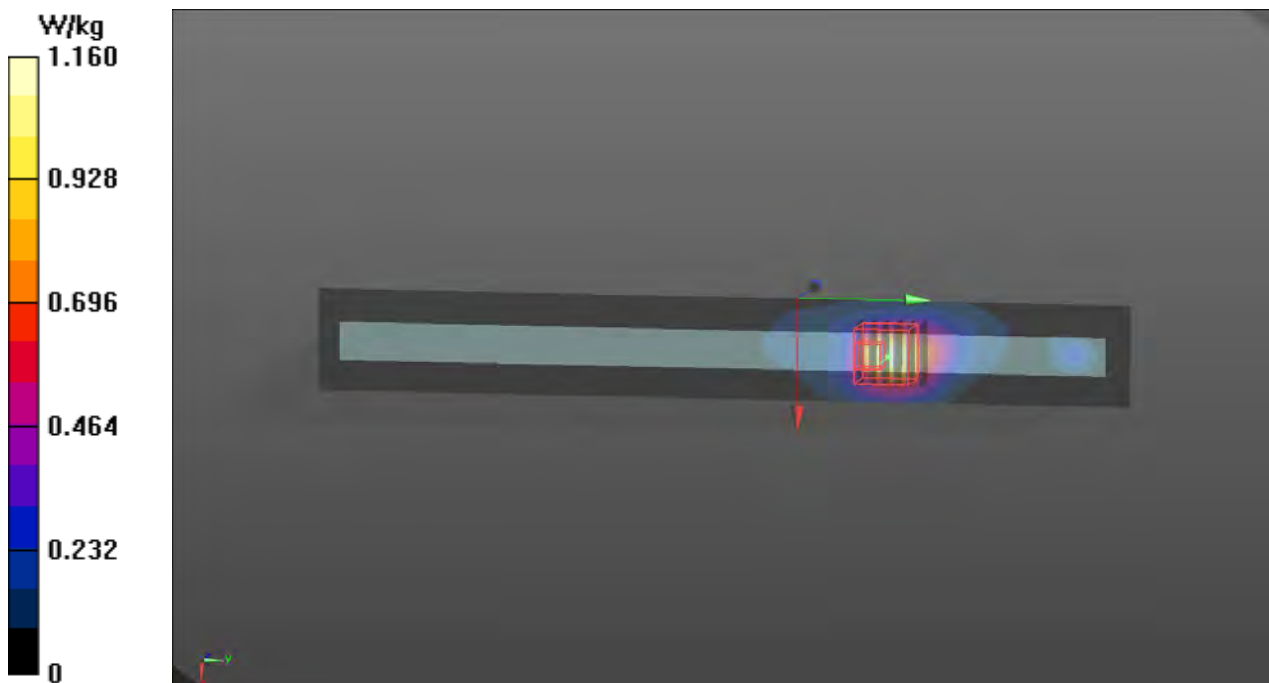

### P37 802.11a\_Rear Face\_0cm\_Ch149\_Ant B\_ACON

**DUT: 512732-02\_ACON**

Communication System: WLAN\_5G; Frequency: 5745 MHz; Duty Cycle: 1:1  
Medium: B5G\_150721 Medium parameters used:  $f = 5745$  MHz;  $\sigma = 6.096$  S/m;  $\epsilon_r = 47.828$ ;  $\rho = 1000$  kg/m<sup>3</sup>

**Ambient Temperature : 23.3 °C; Liquid Temperature : 22.4 °C**

DASY5 Configuration:

- Probe: EX3DV4 - SN3976; ConvF(4.23, 4.23, 4.23); Calibrated: 2015/2/26;
- Sensor-Surface: 2mm (Mechanical Surface Detection)
- Electronics: DAE4 Sn1424; Calibrated: 2015/2/20
- Phantom: ELI v5.0; Type: QDOVA002AA; Serial: TP:1238
- Measurement SW: DASY52, Version 52.8 (8); SEMCAD X Version 14.6.10 (7331)

**Ch149/Area Scan (241x321x1):** Interpolated grid: dx=1.000 mm, dy=1.000 mm  
Maximum value of SAR (interpolated) = 0.466 W/kg

**Ch149/Zoom Scan (6x6x12)/Cube 0:** Measurement grid: dx=5mm, dy=5mm, dz=2mm

Reference Value = 9.499 V/m; Power Drift = 0.06 dB

Peak SAR (extrapolated) = 1.07 W/kg

**SAR(1 g) = 0.257 W/kg; SAR(10 g) = 0.087 W/kg**

Maximum value of SAR (measured) = 0.509 W/kg

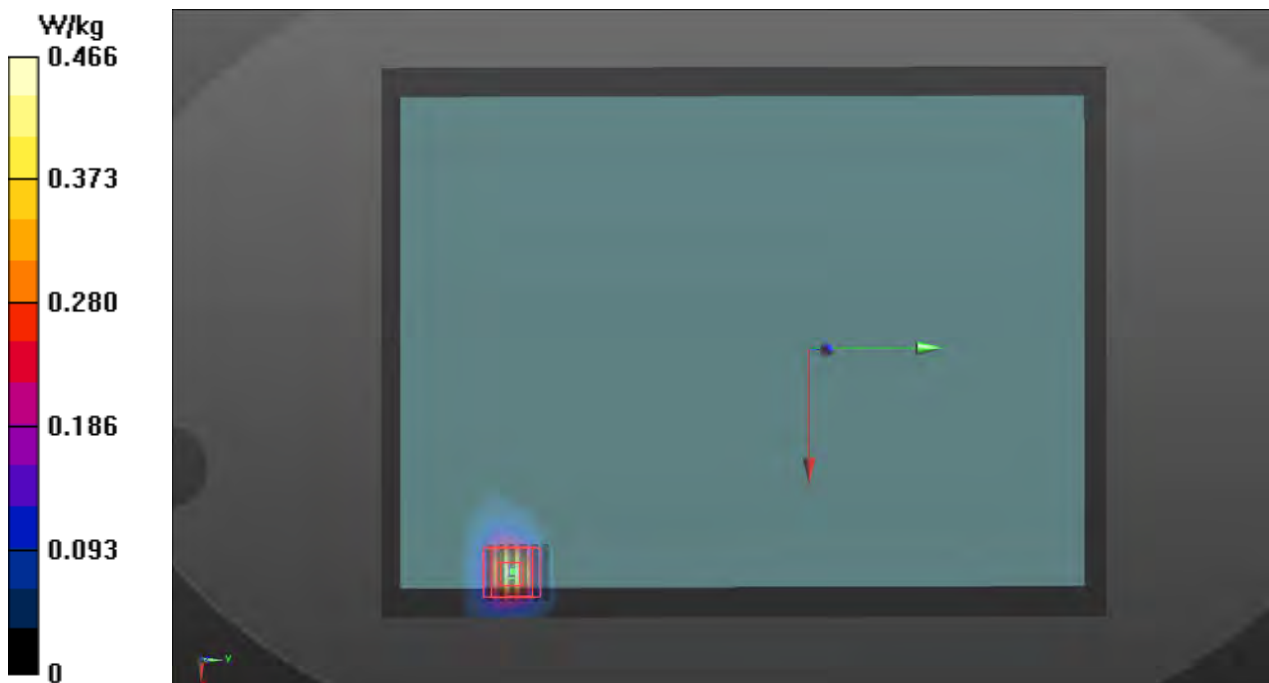

### P38 802.11a\_Edge3\_0cm\_Ch149\_Ant B\_ACON

**DUT: 512732-02\_ACON**

Communication System: WLAN\_5G; Frequency: 5745 MHz; Duty Cycle: 1:1  
Medium: B5G\_150721 Medium parameters used:  $f = 5745$  MHz;  $\sigma = 6.096$  S/m;  $\epsilon_r = 47.828$ ;  $\rho = 1000$  kg/m<sup>3</sup>

**Ambient Temperature : 23.3 °C; Liquid Temperature : 22.4 °C**

DASY5 Configuration:

- Probe: EX3DV4 - SN3976; ConvF(4.23, 4.23, 4.23); Calibrated: 2015/2/26;
- Sensor-Surface: 2mm (Mechanical Surface Detection)
- Electronics: DAE4 Sn1424; Calibrated: 2015/2/20
- Phantom: ELI v5.0; Type: QDOVA002AA; Serial: TP:1238
- Measurement SW: DASY52, Version 52.8 (8); SEMCAD X Version 14.6.10 (7331)

**Ch149/Area Scan (41x321x1):** Interpolated grid: dx=1.000 mm, dy=1.000 mm  
Maximum value of SAR (interpolated) = 0.485 W/kg

**Ch149/Zoom Scan (6x6x12)/Cube 0:** Measurement grid: dx=5mm, dy=5mm, dz=2mm

Reference Value = 8.789 V/m; Power Drift = 0.03 dB

Peak SAR (extrapolated) = 1.15 W/kg

**SAR(1 g) = 0.270 W/kg; SAR(10 g) = 0.090 W/kg**

Maximum value of SAR (measured) = 0.560 W/kg

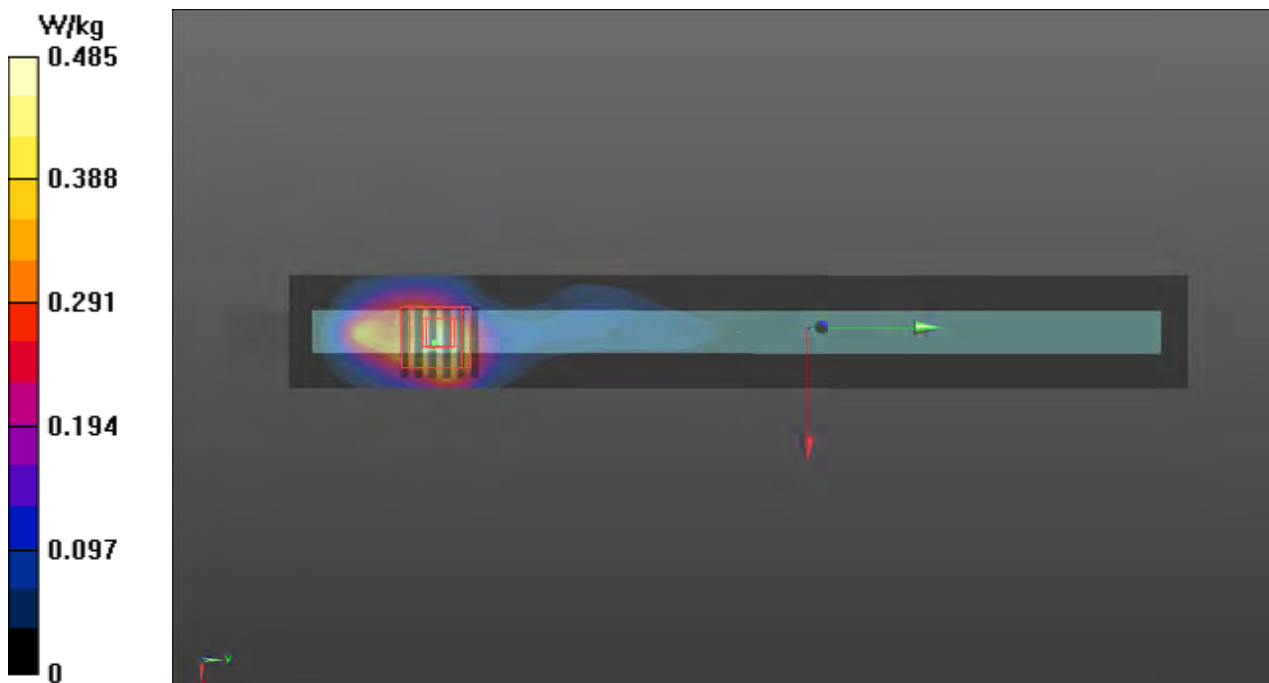

### P39 802.11a\_Rear Face\_0cm\_Ch149\_Ant B\_Inpaq

#### DUT: 512732-02\_Inpaq

Communication System: WLAN\_5G; Frequency: 5745 MHz; Duty Cycle: 1:1  
Medium: B5G\_150717 Medium parameters used:  $f = 5745$  MHz;  $\sigma = 6.097$  S/m;  $\epsilon_r = 47.825$ ;  $\rho = 1000$  kg/m<sup>3</sup>

**Ambient Temperature : 23.2 °C; Liquid Temperature : 22.6 °C**

#### DASY5 Configuration:

- Probe: EX3DV4 - SN3976; ConvF(4.23, 4.23, 4.23); Calibrated: 2015/2/26;
- Sensor-Surface: 2mm (Mechanical Surface Detection)
- Electronics: DAE4 Sn1424; Calibrated: 2015/2/20
- Phantom: ELI v5.0; Type: QDOVA002AA; Serial: TP:1238
- Measurement SW: DASY52, Version 52.8 (8); SEMCAD X Version 14.6.10 (7331)

**Ch149/Area Scan (241x321x1):** Interpolated grid: dx=1.000 mm, dy=1.000 mm

Maximum value of SAR (interpolated) = 0.761 W/kg

**Ch149/Zoom Scan (6x6x12)/Cube 0:** Measurement grid: dx=5mm, dy=5mm, dz=2mm

Reference Value = 0.9570 V/m; Power Drift = -0.04 dB

Peak SAR (extrapolated) = 1.77 W/kg

**SAR(1 g) = 0.424 W/kg; SAR(10 g) = 0.150 W/kg**

Maximum value of SAR (measured) = 0.782 W/kg

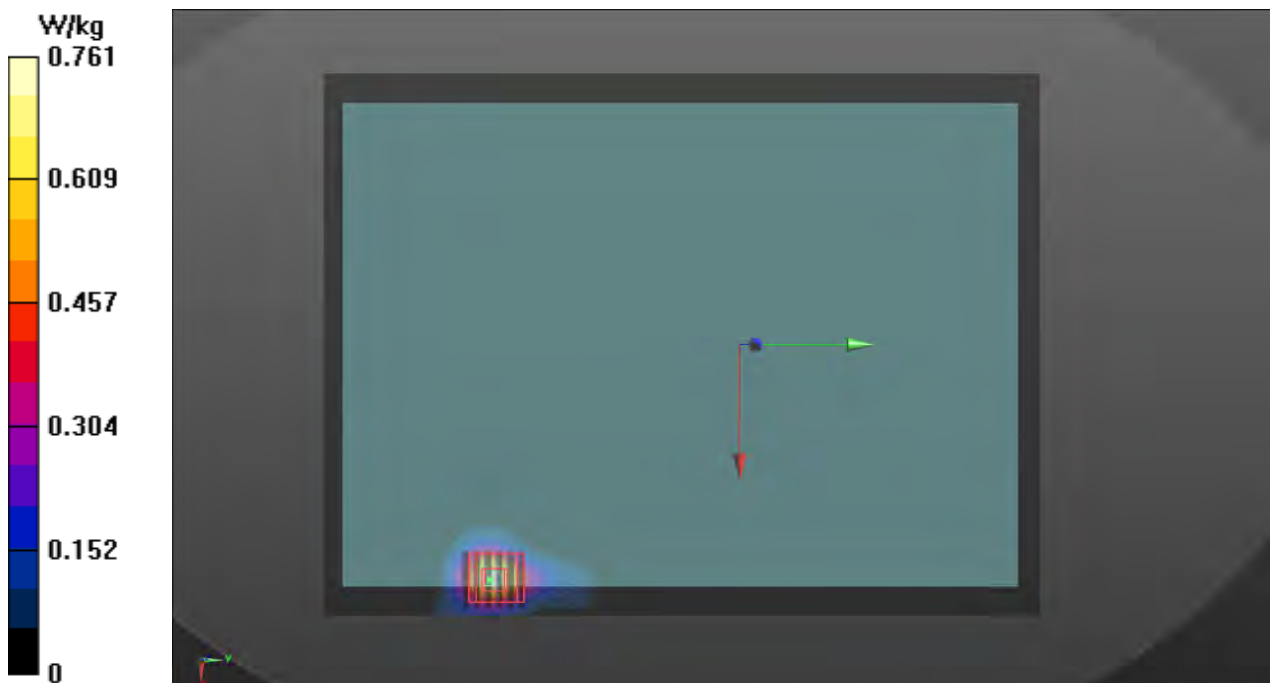



### P40 802.11a\_Edge3\_0cm\_Ch149\_Ant B\_Inpaq

#### DUT: 512732-02\_Inpaq

Communication System: WLAN\_5G; Frequency: 5745 MHz; Duty Cycle: 1:1  
Medium: B5G\_150717 Medium parameters used:  $f = 5745$  MHz;  $\sigma = 6.097$  S/m;  $\epsilon_r = 47.825$ ;  $\rho = 1000$  kg/m<sup>3</sup>

**Ambient Temperature : 23.2 °C; Liquid Temperature : 22.6 °C**

#### DASY5 Configuration:

- Probe: EX3DV4 - SN3976; ConvF(4.23, 4.23, 4.23); Calibrated: 2015/2/26;
- Sensor-Surface: 2mm (Mechanical Surface Detection)
- Electronics: DAE4 Sn1424; Calibrated: 2015/2/20
- Phantom: ELI v5.0; Type: QDOVA002AA; Serial: TP:1238
- Measurement SW: DASY52, Version 52.8 (8); SEMCAD X Version 14.6.10 (7331)

**Ch149/Area Scan (41x321x1):** Interpolated grid: dx=1.000 mm, dy=1.000 mm  
Maximum value of SAR (interpolated) = 0.884 W/kg

**Ch149/Zoom Scan (6x6x12)/Cube 0:** Measurement grid: dx=5mm, dy=5mm, dz=2mm  
Reference Value = 12.28 V/m; Power Drift = -0.03 dB  
Peak SAR (extrapolated) = 4.01 W/kg  
**SAR(1 g) = 0.789 W/kg; SAR(10 g) = 0.218 W/kg**  
Maximum value of SAR (measured) = 1.80 W/kg

