



CTC Laboratories, Inc.

1-2/F., Building 2, Jiaquan Building, Guanlan High-Tech Park, Shenzhen, Guangdong, China
Tel: +86-755- 27521059 Fax: +86-755- 27521011 Http://www.sz-ctc.org.cn

TEST REPORT

Report No.: **CTC20201970E03**

FCC ID.....: **2APPZ-H5W**

Applicant.....: **Fanvil Technology Co., Ltd**

Address.....: 10/F Block A, Dualshine Global Science Innovation Center,
Honglang North 2nd Road, Bao'an District, Shenzhen, China

Manufacturer.....: Fanvil Technology Co., Ltd

Address.....: 10/F Block A, Dualshine Global Science Innovation Center,
Honglang North 2nd Road, Bao'an District, Shenzhen, China

Product Name.....: **IP Phone**

Trade Mark.....: Fanvil

Model/Type reference.....: H5W

Listed Model(s): H3W

Standard.....: **FCC CFR Title 47 Part 15 Subpart C Section 15.247**

Date of receipt of test sample...: Dec. 15, 2020

Date of testing.....: Dec. 16, 2020 to Dec. 23, 2020

Date of issue.....: Dec. 25, 2020

Result.....: **PASS**

Compiled by:
(Printed name+signature) Lucy Lan *Lucy Lan*

Supervised by:
(Printed name+signature) Miller Ma *Miller Ma*

Approved by:
(Printed name+signature) Walter Chen

Testing Laboratory Name.....: **CTC Laboratories, Inc.**

Address.....: 1-2/F., Building 2, Jiaquan Building, Guanlan High-Tech Park,
Shenzhen, Guangdong, China

This test report may be duplicated completely for legal use with the approval of the applicant. It should not be reproduced except in full, without the written approval of our laboratory. The client should not use it to claim product endorsement by CTC. The test results in the report only apply to the tested sample. The test report shall be invalid without all the signatures of testing engineers, reviewer and approver. Any objections must be raised to CTC within 15 days since the date when the report is received. It will not be taken into consideration beyond this limit. The test report merely correspond to the test sample.



Table of Contents

Page

- 1. TEST SUMMARY 3
 - 1.1. TEST STANDARDS..... 3
 - 1.2. REPORT VERSION..... 3
 - 1.3. TEST DESCRIPTION..... 4
 - 1.4. TEST FACILITY 5
 - 1.5. MEASUREMENT UNCERTAINTY 5
 - 1.6. ENVIRONMENTAL CONDITIONS 6
- 2. GENERAL INFORMATION 7
 - 2.1. CLIENT INFORMATION 7
 - 2.2. GENERAL DESCRIPTION OF EUT 7
 - 2.3. OPERATION STATE..... 8
 - 2.4. MEASUREMENT INSTRUMENTS LIST 9
- 3. TEST ITEM AND RESULTS 11
 - 3.1. CONDUCTED EMISSION..... 11
 - 3.2. RADIATED EMISSION 14
 - 3.3. BAND EDGE EMISSIONS 54
 - 3.4. BANDWIDTH..... 74
 - 3.5. PEAK OUTPUT POWER 75
 - 3.6. POWER SPECTRAL DENSITY 77
 - 3.7. ANTENNA REQUIREMENT 78
- APPENDIX A1: DTS BANDWIDTH 79
- APPENDIX A2: OCCUPIED CHANNEL BANDWIDTH 84
- APPENDIX B: MAXIMUM POWER SPECTRAL DENSITY..... 89



1. TEST SUMMARY

1.1. Test Standards

The tests were performed according to following standards:

[FCC Rules Part 15.247](#): Operation within the bands of 2400-2483.5MHz,

[ANSI C63.10-2013](#): American National Standard for Testing Unlicensed Wireless Devices.

1.2. Report version

| Revised No. | Date of issue | Description |
|-------------|---------------|-------------|
| 01 | Dec. 25, 2020 | Original |
| | | |
| | | |
| | | |



1.3. Test Description

| FCC Part 15 Subpart C (15.247) | | | |
|--------------------------------|------------------|--------|---------------|
| Test Item | Standard Section | Result | Test Engineer |
| Antenna Requirement | 15.203 | Pass | Lucy Lan |
| Conducted Emission | 15.207 | Pass | Jon Huang |
| Band Edge Emissions | 15.247(d) | Pass | Lucy Lan |
| 6dB Bandwidth | 15.247(a)(2) | Pass | Lucy Lan |
| Conducted Max Output Power | 15.247(b)(3) | Pass | Lucy Lan |
| Power Spectral Density | 15.247(e) | Pass | Lucy Lan |
| Transmitter Radiated Spurious | 15.209&15.247(d) | Pass | Lucy Lan |

Note: The measurement uncertainty is not included in the test result.



1.4. Test Facility

CTC Laboratories, Inc.

Add: 1-2/F., Building 2, Jiaquan Building, Guanlan High-Tech Park, Shenzhen, Guangdong, China

Laboratory accreditation

The test facility is recognized, certified, or accredited by the following organizations:

CNAS-Lab Code: L5365

CTC Laboratories, Inc. has been assessed and proved to be in compliance with CNAS-CL01 Accreditation.

Criteria for Testing and Calibration Laboratories (identical to ISO/IEC17025: 2017 General Requirements) for the Competence of Testing and Calibration Laboratories.

A2LA-Lab Cert. No.: 4340.01

CTC Laboratories, Inc. EMC Laboratory has been accredited by A2LA for technical competence in the field of electrical testing, and proved to be in compliance with ISO/IEC 17025:2017 General Requirements for the Competence of Testing and Calibration Laboratories and any additional program requirements in the identified field of testing.

Industry Canada (Registration No.: 9783A, CAB Identifier: CN0029)

CTC Laboratories, Inc. EMC Laboratory has been registered by Certification and Engineer Bureau of Industry Canada for the performance of with Registration NO.: 9783A on Jan, 2016.

FCC (Registration No.: 951311, Designation Number CN1208)

CTC Laboratories, Inc. EMC Laboratory has been registered and fully described in a report filed with the (FCC) Federal Communications Commission. The acceptance letter from the FCC is maintained in our files. Registration 951311, Aug 26, 2017.

1.5. Measurement Uncertainty

The data and results referenced in this document are true and accurate. The reader is cautioned that there may be errors within the calibration limits of the equipment and facilities. The measurement uncertainty was calculated for all measurements listed in this test report acc. to TR-100028-01 "Electromagnetic compatibility and Radio spectrum Matters (ERM); Uncertainties in the measurement of mobile radio equipment characteristics; Part 1" and TR-100028-02 "Electromagnetic compatibility and Radio spectrum Matters (ERM); Uncertainties in the measurement of mobile radio equipment characteristics; Part 2" and is documented in the CTC Laboratories, Inc. quality system acc. to DIN EN ISO/IEC 17025. Furthermore, component and process variability of devices similar to that tested may result in additional deviation. The manufacturer has the sole responsibility of continued compliance of the device.

Below is the best measurement capability for CTC Laboratories, Inc.



| Test Items | Measurement Uncertainty | Notes |
|---|-------------------------|-------|
| Transmitter power conducted | 0.42 dB | (1) |
| Transmitter power Radiated | 2.14 dB | (1) |
| Conducted spurious emissions 9kHz~40GHz | 1.60 dB | (1) |
| Radiated spurious emissions 9kHz~40GHz | 2.20 dB | (1) |
| Conducted Emissions 9kHz~30MHz | 3.20 dB | (1) |
| Radiated Emissions 30~1000MHz | 4.70 dB | (1) |
| Radiated Emissions 1~18GHz | 5.00 dB | (1) |
| Radiated Emissions 18~40GHz | 5.54 dB | (1) |
| Occupied Bandwidth | ----- | (1) |

Note (1): This uncertainty represents an expanded uncertainty expressed at approximately the 95% confidence level using a coverage factor of $k=1.96$.

1.6. Environmental conditions

During the measurement the environmental conditions were within the listed ranges:

| | |
|--------------------|-------------|
| Temperature: | 21°C ~ 27°C |
| Relative Humidity: | 40% ~ 60% |
| Air Pressure: | 101kPa |



2. GENERAL INFORMATION

2.1. Client Information

| | |
|---------------|---|
| Applicant: | Fanvil Technology Co., Ltd |
| Address: | 10/F Block A, Dualshine Global Science Innovation Center, Honglang North 2nd Road, Bao'an District, Shenzhen, China |
| Manufacturer: | Fanvil Technology Co., Ltd |
| Address: | 10/F Block A, Dualshine Global Science Innovation Center, Honglang North 2nd Road, Bao'an District, Shenzhen, China |

2.2. General Description of EUT

| | |
|--|--|
| Product Name: | IP Phone |
| Trade Mark: | Fanvil |
| Model/Type reference: | H5W |
| Listed Model(s): | H3W |
| Model Difference: | All these models are identical in the same PCB, layout and electrical circuit, Different is model number and H5W with LCD monitor which H3W without. |
| Power supply: | 5V=2A form AC/DC Adapter or PoE 48V |
| Adapter Model: | F12W8-050200SPAU L.P.S INPUT:100-240V 50/60Hz 0.3A OUTPUT:5V/2A |
| Hardware version: | N/A |
| Software version: | N/A |
| WIFI 802.11b/ g/ n(HT20)/ n(HT40) | |
| Modulation: | 802.11b: DSSS(CCK, DQPSK, DBPSK) 802.11g/n: OFDM(BPSK, QPSK, 16QAM, 64QAM) |
| Operation frequency: | 802.11b/g/n(HT20): 2412MHz~2462MHz 802.11n(HT40): 2422MHz~2452MHz |
| Channel number: | 802.11b/g/n(HT20):11channels 802.11n(HT40):7channels |
| Channel separation: | 5MHz |
| Antenna type: | FPC Antenna |
| Antenna gain: | 3.7dBi |



2.3. Operation state

Operation Frequency List: The EUT has been tested under typical operating condition. The Applicant provides communication tools software to control the EUT for staying in continuous transmitting and receiving mode for testing.

Operation Frequency List:

| Channel | Frequency (MHz) |
|---------|-----------------|
| 01 | 2412 |
| 02 | 2417 |
| 03 | 2422 |
| 04 | 2427 |
| 05 | 2432 |
| 06 | 2437 |
| 07 | 2442 |
| 08 | 2447 |
| 09 | 2452 |
| 10 | 2457 |
| 11 | 2462 |

Note: CH 01~CH 11 for 802.11b/g/n(HT20), CH 03~CH 09 for 802.11n(HT40)

Data Rated

Preliminary tests were performed in different data rate, and found which the below bit rate is worst case mode, so only show data which it is a worst case mode.

| Mode | Data rate (worst mode) |
|---------------|------------------------|
| 802.11b | 1Mbps |
| 802.11g | 6Mbps |
| 802.11n(HT20) | HT-MCS0 |
| 802.11n(HT40) | HT-MCS0 |

Test mode

| |
|--|
| For RF test items: |
| The engineering test program was provided and enabled to make EUT continuous transmit. |
| For AC power line conducted emissions: |
| The EUT was set to connect with the WLAN AP under large package sizes transmission. |
| For Radiated spurious emissions test item: |
| The engineering test program was provided and enabled to make EUT continuous transmit. The EUT in each of three orthogonal axis emissions had been tested, but only the worst case (X axis) data Recorded in the report. |



2.4. Measurement Instruments List

| Tonscend JS0806-2 Test system | | | | | |
|-------------------------------|-------------------------------------|-----------------|-----------|------------|------------------|
| Item | Test Equipment | Manufacturer | Model No. | Serial No. | Calibrated until |
| 1 | Spectrum Analyzer | Rohde & Schwarz | FSU26 | 100105 | Dec. 27, 2020 |
| 2 | Spectrum Analyzer | Rohde & Schwarz | FUV40-N | 101331 | Mar. 15, 2021 |
| 3 | MXG Vector Signal Generator | Agilent | N5182A | MY47420864 | Dec. 27, 2020 |
| 4 | Signal Generator | Agilent | E8257D | MY46521908 | Dec. 27, 2020 |
| 5 | Power Sensor | Agilent | U2021XA | MY5365004 | Dec. 27, 2020 |
| 6 | Power Sensor | Agilent | U2021XA | MY5365006 | Dec. 27, 2020 |
| 7 | Simultaneous Sampling DAQ | Agilent | U2531A | TW54493510 | Dec. 27, 2020 |
| 8 | Climate Chamber | TABAI | PR-4G | A8708055 | Dec. 27, 2020 |
| 9 | Wideband Radio Communication Tester | Rohde & Schwarz | CMW500 | 116410 | Dec. 27, 2020 |
| 10 | Climate Chamber | ESPEC | MT3065 | / | Dec. 27, 2020 |
| 11 | 300328 v2.2.2 test system | TONSCEND | v2.6 | / | / |

| Radiated Emission and Transmitter spurious emissions | | | | | |
|--|-------------------------|---------------------|--------------|------------|------------------|
| Item | Test Equipment | Manufacturer | Model No. | Serial No. | Calibrated until |
| 1 | EMI Test Receiver | Rohde & Schwarz | ESCI | 100658 | Dec. 27, 2020 |
| 2 | High pass filter | micro-tranics | HPM50111 | 142 | Dec. 27, 2020 |
| 3 | Log-Bicon Antenna | Schwarzbeck | CBL6141A | 4180 | Dec. 27, 2020 |
| 4 | Ultra-Broadband Antenna | ShwarzBeck | BBHA9170 | 25841 | Dec. 27, 2020 |
| 5 | Loop Antenna | LAPLAC | RF300 | 9138 | Dec. 27, 2020 |
| 6 | Spectrum Analyzer | Rohde & Schwarz | FSU26 | 100105 | Dec. 27, 2020 |
| 7 | Horn Antenna | Schwarzbeck | BBHA 9120D | 647 | Dec. 27, 2020 |
| 8 | Pre-Amplifier | HP | 8447D | 1937A03050 | Dec. 27, 2020 |
| 9 | Pre-Amplifier | EMCI | EMC051835 | 980075 | Dec. 27, 2020 |
| 10 | Antenna Mast | UC | UC3000 | N/A | N/A |
| 11 | Turn Table | UC | UC3000 | N/A | N/A |
| 12 | Cable Below 1GHz | Schwarzbeck | AK9515E | 33155 | Dec. 27, 2020 |
| 13 | Cable Above 1GHz | Hubersuhner | SUCOFLEX 102 | DA1580 | Dec. 27, 2020 |
| 14 | Splitter | Mini-Circuit | ZAPD-4 | 400059 | Dec. 27, 2020 |
| 15 | RF Connection Cable | HUBER+SUHNER | RE-7-FL | N/A | Dec. 27, 2020 |
| 16 | RF Connection Cable | Chengdu E-Microwave | --- | --- | Dec. 27, 2020 |
| 17 | High pass filter | Compliance | BSU-6 | 34202 | Dec. 27, 2020 |

CTC Laboratories, Inc.

1-2/F., Building 2, Jiaquan Building, Guanlan High-Tech Park, Shenzhen, Guangdong, China

Tel.: (86)755-27521059

Fax: (86)755-27521011

Http://www.sz-ctc.org.cn

中国国家认证认可监督管理委员会
Certification and Accreditation Administration of the People's Republic of ChinaFor anti-fake verification, please visit the official website of Certification and Accreditation Administration of the People's Republic of China: yz.cnca.cn



| | | | | | |
|----|---------------------------------|------------------------|--------------------|----------|---------------|
| | | Direction systems | | | |
| 18 | Attenuator | Chengdu E-Microwave | EMCAXX-10 RNZ-3 | --- | Dec. 27, 2020 |
| 19 | High and low temperature box | ESPEC | MT3065 | 12114019 | Dec. 27, 2020 |

| Conducted Emission | | | | | |
|--------------------|-------------------|--------------|-----------|------------|------------------|
| Item | Test Equipment | Manufacturer | Model No. | Serial No. | Calibrated until |
| 1 | LISN | R&S | ENV216 | 101112 | Dec. 27, 2020 |
| 2 | LISN | R&S | ENV216 | 101113 | Dec. 27, 2020 |
| 3 | EMI Test Receiver | R&S | ESCI | 100658 | Dec. 27, 2020 |

Note:1. The Cal. Interval was one year.

2. The cable loss has calculated in test result which connection between each test instruments.

3. TEST ITEM AND RESULTS

3.1. Conducted Emission

Limit

FCC CFR Title 47 Part 15 Subpart C Section 15.207

| Frequency range (MHz) | Limit (dBuV) | |
|-----------------------|--------------|-----------|
| | Quasi-peak | Average |
| 0.15-0.5 | 66 to 56* | 56 to 46* |
| 0.5-5 | 56 | 46 |
| 5-30 | 60 | 50 |

* Decreases with the logarithm of the frequency.

Test Configuration

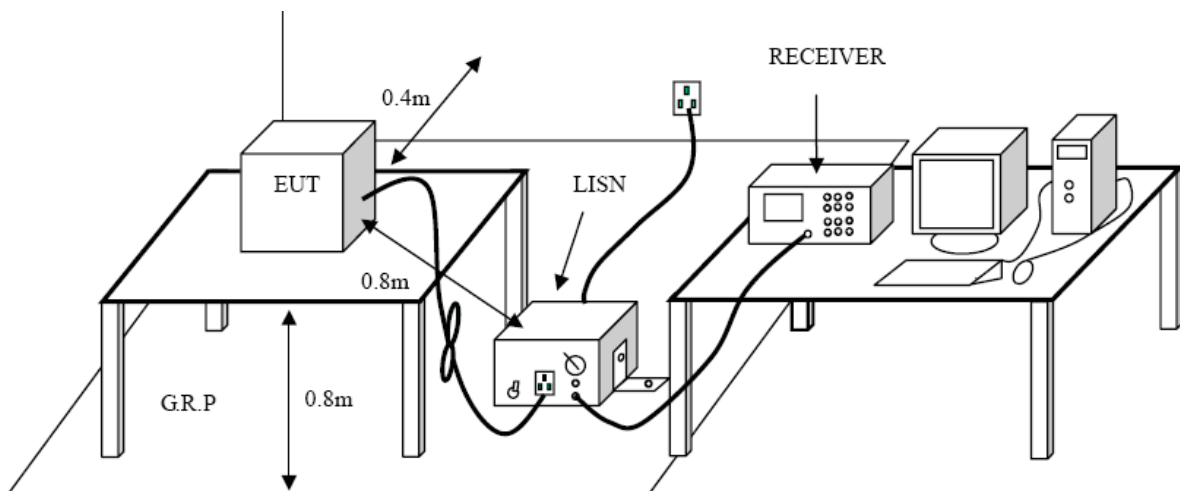

Test Procedure

1. The EUT was setup according to ANSI C63.10:2013 requirements.
2. The EUT was placed on a platform of nominal size, 1 m by 1.5 m, raised 80 cm above the conducting ground plane. The vertical conducting plane was located 40 cm to the rear of the EUT. All other surfaces of EUT were at least 80 cm from any other grounded conducting surface.
3. The EUT and simulators are connected to the main power through a line impedances stabilization network (LISN). The LISN provides a 50ohm /50uH coupling impedance for the measuring equipment. The peripheral devices are also connected to the main power through a LISN. (Please refer to the block diagram of the test setup and photographs)
4. Each current-carrying conductor of the EUT power cord, except the ground (safety) conductor, was individually connected through a LISN to the input power source.
5. The excess length of the power cord between the EUT and the LISN receptacle were folded back and forth at the center of the lead to form a bundle not exceeding 40 cm in length.
6. Conducted Emissions were investigated over the frequency range from 0.15MHz to 30MHz using a receiver bandwidth of 9 kHz.
7. During the above scans, the emissions were maximized by cable manipulation.



Test Mode:

Please refer to the clause 2.3.

Test Results

| | |
|----------------------|---------------|
| Test Voltage: | AC 120V/60 Hz |
| Terminal: | Line |

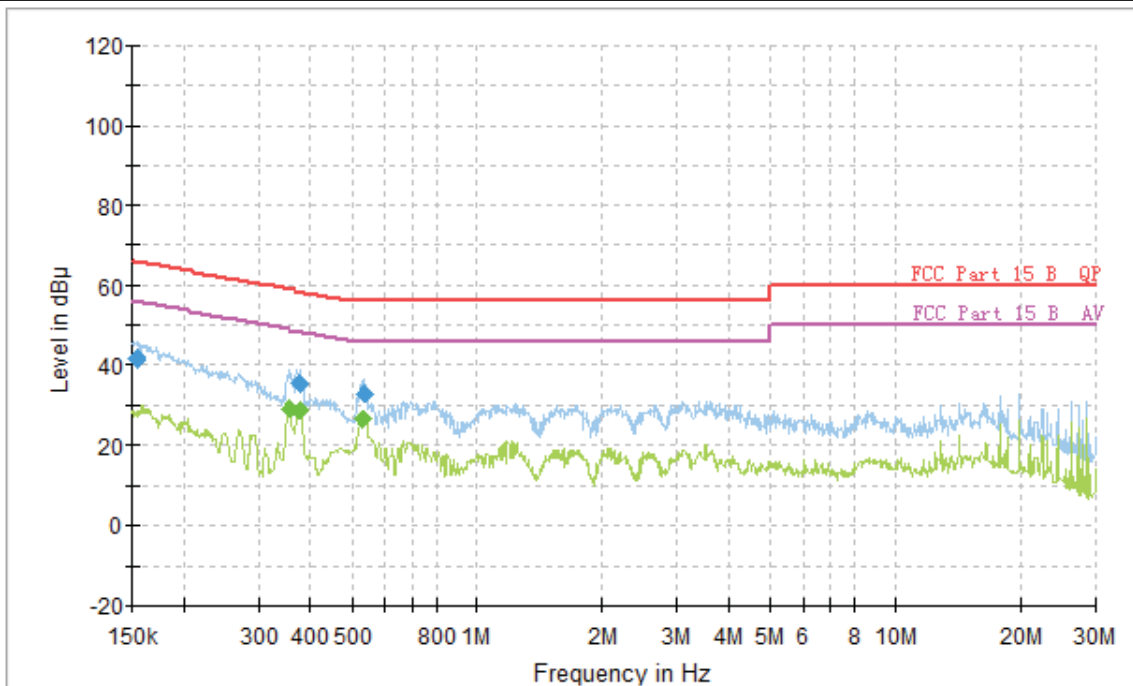

Final Measurement Detector 1

| Frequency (MHz) | QuasiPeak (dB μV) | Meas. Time (ms) | Bandwidth (kHz) | Filter | Line | Corr. (dB) | Margin (dB) | Limit (dB μV) | Comment |
|-----------------|-------------------|-----------------|-----------------|--------|------|------------|-------------|---------------|---------|
| 0.153020 | 41.6 | 1000.00 | 9.000 | On | L1 | 10.4 | 24.2 | 65.8 | |
| 0.375700 | 35.7 | 1000.00 | 9.000 | On | L1 | 10.4 | 22.7 | 58.4 | |
| 0.535980 | 32.7 | 1000.00 | 9.000 | On | L1 | 10.4 | 23.3 | 56.0 | |

Final Measurement Detector 2

| Frequency (MHz) | Average (dB μV) | Meas. Time (ms) | Bandwidth (kHz) | Filter | Line | Corr. (dB) | Margin (dB) | Limit (dB μV) | Comment |
|-----------------|-----------------|-----------------|-----------------|--------|------|------------|-------------|---------------|---------|
| 0.355280 | 29.1 | 1000.00 | 9.000 | On | L1 | 10.4 | 19.7 | 48.8 | |
| 0.375700 | 28.5 | 1000.00 | 9.000 | On | L1 | 10.4 | 19.9 | 48.4 | |
| 0.533840 | 26.9 | 1000.00 | 9.000 | On | L1 | 10.4 | 19.1 | 46.0 | |

Emission Level= Read Level+ Correct Factor



| | |
|---------------|---------------|
| Test Voltage: | AC 120V/60 Hz |
| Terminal: | Neutral |

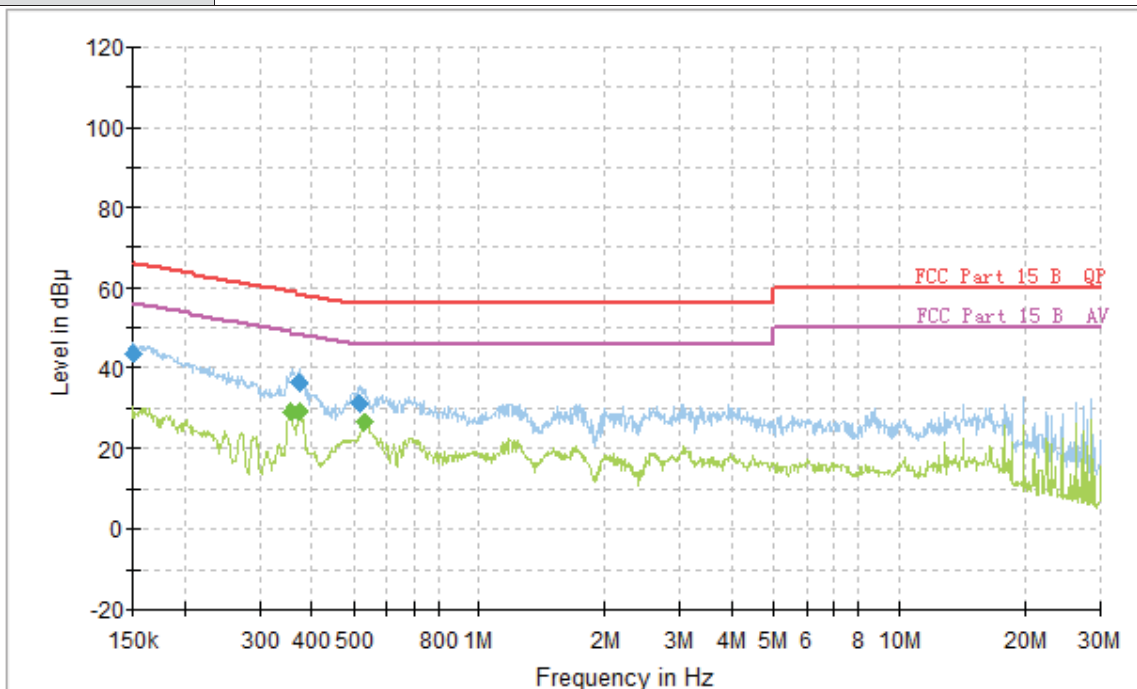

Final Measurement Detector 1

| Frequency (MHz) | QuasiPeak (dB µV) | Meas. Time (ms) | Bandwidth (kHz) | Filter | Line | Corr. (dB) | Margin (dB) | Limit (dB µV) | Comment |
|-----------------|-------------------|-----------------|-----------------|--------|------|------------|-------------|---------------|---------|
| 0.150000 | 43.6 | 1000.00 | 9.000 | On | N | 10.7 | 22.4 | 66.0 | |
| 0.374210 | 36.5 | 1000.00 | 9.000 | On | N | 10.7 | 21.9 | 58.4 | |
| 0.517060 | 31.3 | 1000.00 | 9.000 | On | N | 10.7 | 24.7 | 56.0 | |

Final Measurement Detector 2

| Frequency (MHz) | Average (dB µV) | Meas. Time (ms) | Bandwidth (kHz) | Filter | Line | Corr. (dB) | Margin (dB) | Limit (dB µV) | Comment |
|-----------------|-----------------|-----------------|-----------------|--------|------|------------|-------------|---------------|---------|
| 0.356700 | 29.2 | 1000.00 | 9.000 | On | N | 10.7 | 19.6 | 48.8 | |
| 0.374210 | 29.3 | 1000.00 | 9.000 | On | N | 10.7 | 19.1 | 48.4 | |
| 0.533840 | 26.9 | 1000.00 | 9.000 | On | N | 10.7 | 19.1 | 46.0 | |

Emission Level= Read Level+ Correct Factor

3.2. Radiated Emission

Limit

FCC CFR Title 47 Part 15 Subpart C Section 15.209/ RSS – Gen 8.9:

| Frequency | Limit (dBuV/m @3m) | Value |
|-------------------|--------------------|------------|
| 30 MHz ~ 88 MHz | 40.00 | Quasi-peak |
| 88 MHz ~ 216 MHz | 43.50 | Quasi-peak |
| 216 MHz ~ 960 MHz | 46.00 | Quasi-peak |
| 960 MHz ~ 1 GHz | 54.00 | Quasi-peak |
| Above 1 GHz | 54.00 | Average |
| | 74.00 | Peak |

Conducted Emission limit: The highest point of the operating frequency waveform down 20dB

Note:

- (1) The tighter limit applies at the band edges.
- (2) Emission Level (dBuV/m)=20log Emission Level (uV/m).

Test Configuration

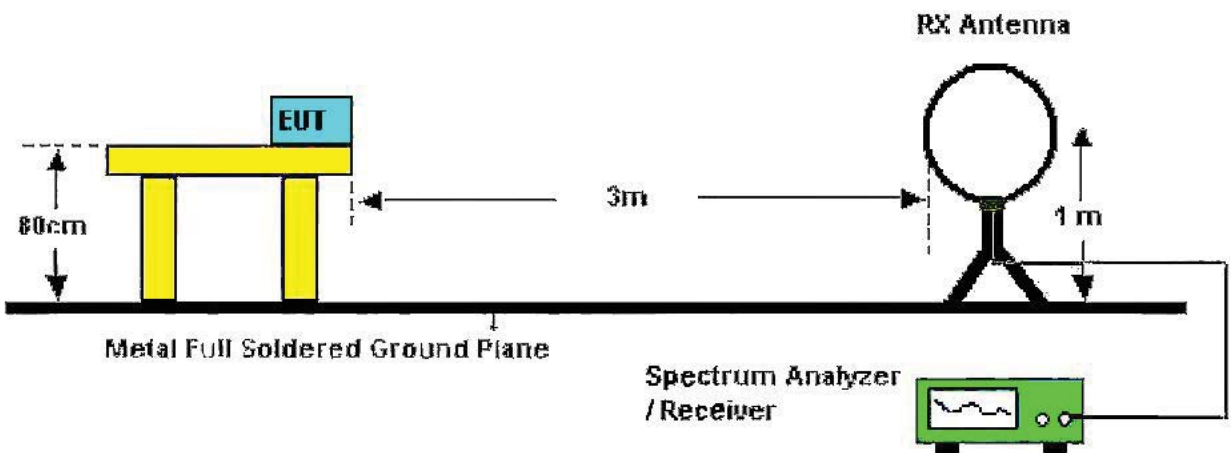
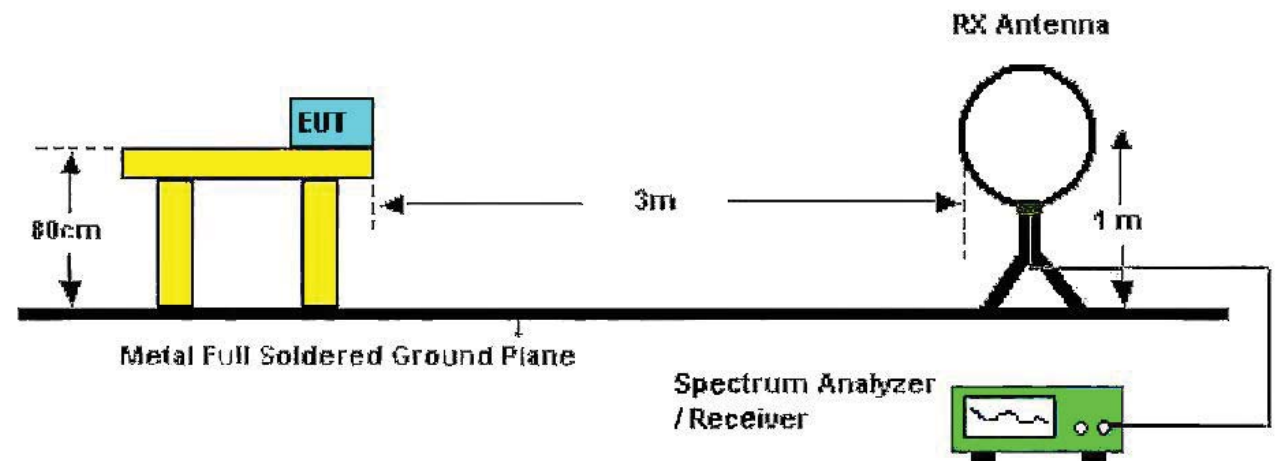

Below 30MHz Test Setup

Below 1000MHz Test Setup

CTC Laboratories, Inc.

1-2/F., Building 2, Jiaquan Building, Guanlan High-Tech Park, Shenzhen, Guangdong, China
 Tel.: (86)755-27521059 Fax: (86)755-27521011 Http://www.sz-ctc.org.cn

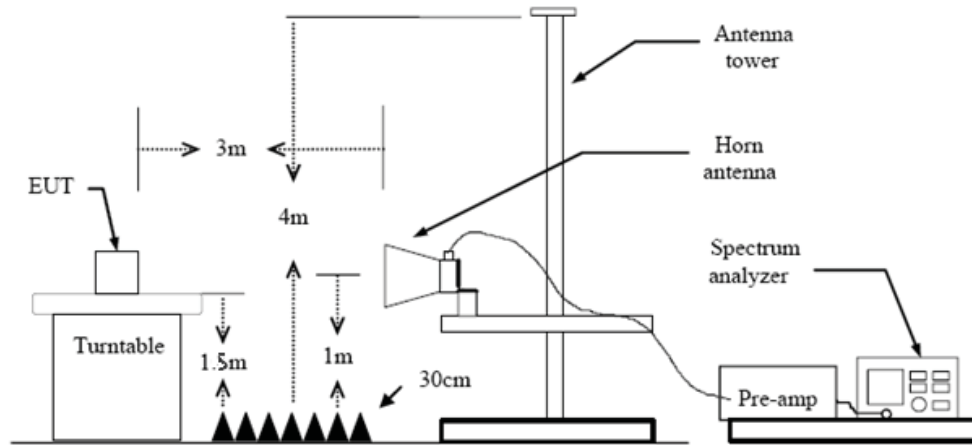

Above 1GHz Test Setup

Test Procedure

1. The EUT was setup and tested according to ANSI C63.10:2013
2. The EUT is placed on a turn table which is 0.8 meter above ground for below 1 GHz, and 1.5 m for above 1 GHz. The turn table is rotated 360 degrees to determine the position of the maximum emission level.
3. The EUT was set 3 meters from the receiving antenna, which was mounted on the top of a variable height antenna tower.
4. For each suspected emission, the EUT was arranged to its worst case and then tune the Antenna tower (from 1 m to 4 m) and turntable (from 0 degree to 360 degrees) to find the maximum reading. A pre-amp and a high pass filter are used for the test in order to get better signal level to comply with the guidelines.
5. Set to the maximum power setting and enable the EUT transmit continuously.
6. Use the following spectrum analyzer settings
 - (1) Span shall wide enough to fully capture the emission being measured;
 - (2) Below 1 GHz:
RBW=120 kHz, VBW=300 kHz, Sweep=auto, Detector function=peak, Trace=max hold;
If the emission level of the EUT measured by the peak detector is 3 dB lower than the applicable limit, the peak emission level will be reported. Otherwise, the emission measurement will be repeated using the quasi-peak detector and reported.
 - (3) From 1 GHz to 10th harmonic:
RBW=1MHz, VBW=3MHz Peak detector for Peak value.
RBW=1MHz, VBW=3MHz RMS detector for Average value.

Test Mode

Please refer to the clause 2.3.

Test Result

9 KHz~30 MHz

From 9 KHz to 30 MHz: Conclusion: PASS

Note: The amplitude of spurious emissions which are attenuated by more than 20dB below the permissible value has no need to be reported.



30MHz-1GHz

| | |
|------------|-----------------------------|
| Ant. Pol. | Horizontal |
| Test Mode: | 802.11b Mode 2412MHz |
| Remark: | Only worse case is reported |



| No. | Frequency (MHz) | Factor (dB/m) | Reading (dBuV) | Level (dBuV/m) | Limit (dBuV/m) | Margin (dB) | Detector |
|-----|-----------------|---------------|----------------|----------------|----------------|-------------|----------|
| 1 | 68.8721 | -20.19 | 50.70 | 30.51 | 40.00 | -9.49 | QP |
| 2 | 112.9196 | -19.89 | 52.05 | 32.16 | 43.50 | -11.34 | QP |
| 3 | 138.3873 | -17.79 | 51.23 | 33.44 | 43.50 | -10.06 | QP |
| 4 | 148.4410 | -16.91 | 51.92 | 35.01 | 43.50 | -8.49 | QP |
| 5 | 206.3975 | -20.67 | 53.21 | 32.54 | 43.50 | -10.96 | QP |
| 6 | 250.3011 | -19.11 | 53.90 | 34.79 | 46.00 | -11.21 | QP |

Remarks:

- 1. Factor (dB/m) = Antenna Factor (dB/m)+Cable Factor (dB)-Pre-amplifier Factor
- 2. Margin value = Level -Limit value



| | |
|------------|-----------------------------|
| Ant. Pol. | Vertical |
| Test Mode: | 802.11b Mode 2412MHz |
| Remark: | Only worse case is reported |

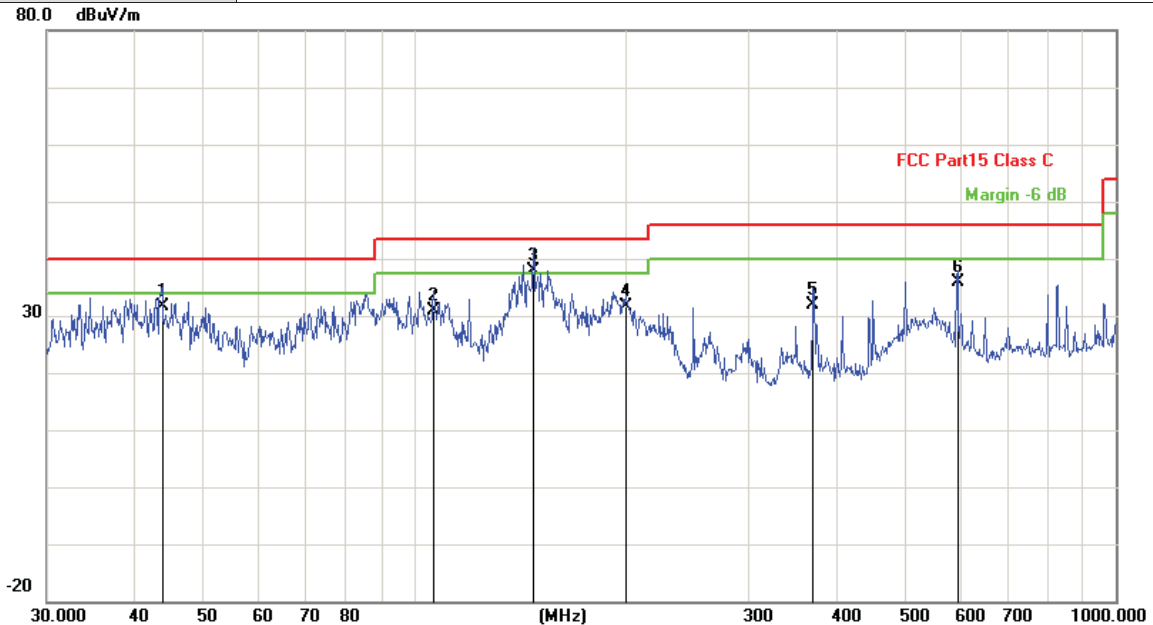

| No. | Frequency (MHz) | Factor (dB/m) | Reading (dBuV) | Level (dBuV/m) | Limit (dBuV/m) | Margin (dB) | Detector |
|-----|-----------------|---------------|----------------|----------------|----------------|-------------|----------|
| 1 | 43.8119 | -17.58 | 49.21 | 31.63 | 40.00 | -8.37 | QP |
| 2 | 106.7587 | -20.41 | 51.26 | 30.85 | 43.50 | -12.65 | QP |
| 3 | 147.9214 | -16.95 | 54.83 | 37.88 | 43.50 | -5.62 | QP |
| 4 | 200.6881 | -20.87 | 52.40 | 31.53 | 43.50 | -11.97 | QP |
| 5 | 370.7023 | -16.34 | 48.22 | 31.88 | 46.00 | -14.12 | QP |
| 6 | 595.1329 | -12.31 | 48.13 | 35.82 | 46.00 | -10.18 | QP |

Remarks:

- Factor (dB/m) = Antenna Factor (dB/m)+Cable Factor (dB)-Pre-amplifier Factor
- Margin value = Level -Limit value



Adobe 1GHz

| | |
|------------|--|
| Ant. Pol. | Horizontal |
| Test Mode: | TX B Mode 2412MHz |
| Remark: | No report for the emission which more than 10 dB below the prescribed limit. |

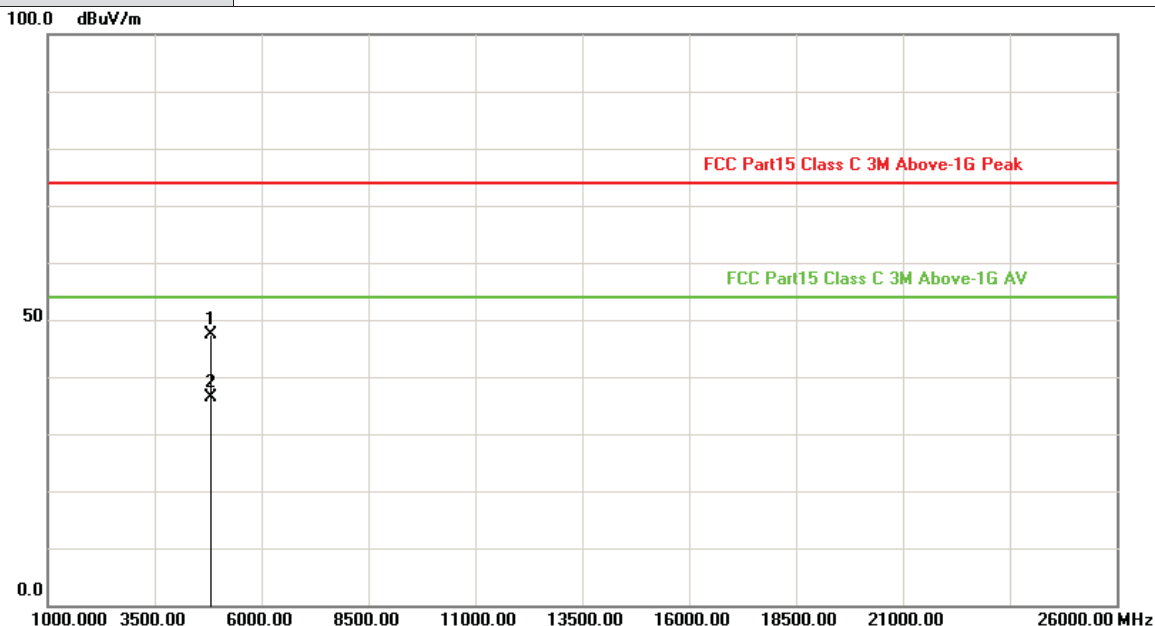

| No. | Frequency (MHz) | Factor (dB/m) | Reading (dBuV) | Level (dBuV/m) | Limit (dBuV/m) | Margin (dB) | Detector |
|-----|-----------------|---------------|----------------|----------------|----------------|-------------|----------|
| 1 | 4824.003 | -2.76 | 50.17 | 47.41 | 74.00 | -26.59 | peak |
| 2 | 4823.970 | -2.76 | 39.02 | 36.26 | 54.00 | -17.74 | AVG |

Remarks:

- 1. Factor (dB/m) = Antenna Factor (dB/m)+Cable Factor (dB)-Pre-amplifier Factor
- 2. Margin value = Level -Limit value



| | |
|-------------------|--|
| Ant. Pol. | Vertical |
| Test Mode: | TX B Mode 2412MHz |
| Remark: | No report for the emission which more than 10 dB below the prescribed limit. |

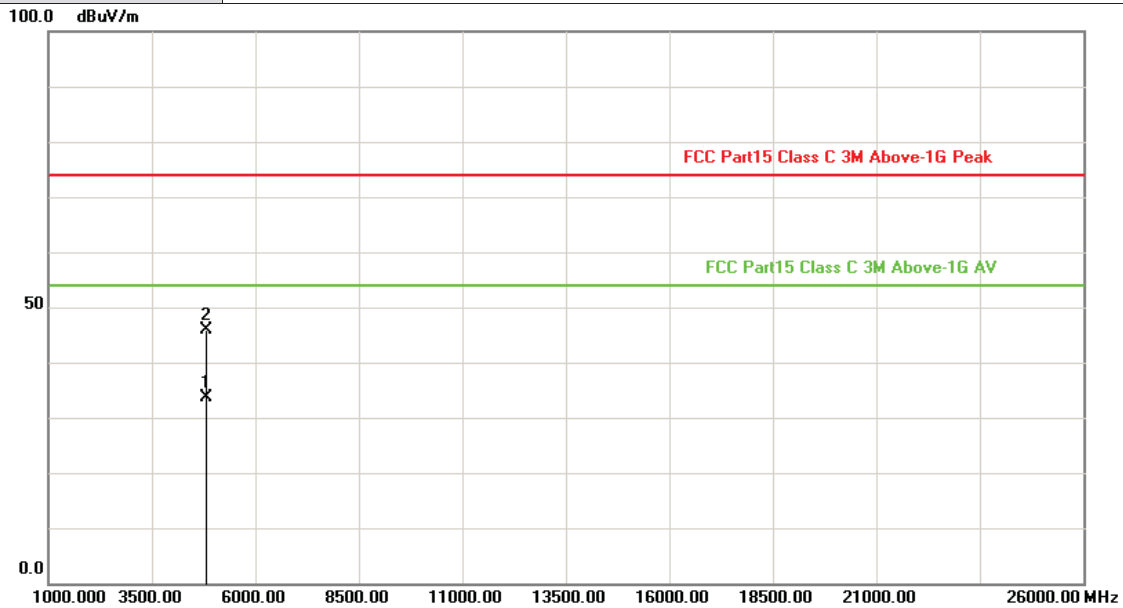

| No. | Frequency (MHz) | Factor (dB/m) | Reading (dBuV) | Level (dBuV/m) | Limit (dBuV/m) | Margin (dB) | Detector |
|-----|-----------------|---------------|----------------|----------------|----------------|-------------|----------|
| 1 | 4824.117 | -2.76 | 36.32 | 33.56 | 54.00 | -20.44 | AVG |
| 2 | 4823.916 | -2.76 | 48.52 | 45.76 | 74.00 | -28.24 | peak |

Remarks:

- 1. Factor (dB/m) = Antenna Factor (dB/m)+Cable Factor (dB)-Pre-amplifier Factor
- 2. Margin value = Level -Limit value



| | |
|-------------------|--|
| Ant. Pol. | Horizontal |
| Test Mode: | TX B Mode 2437MHz |
| Remark: | No report for the emission which more than 10 dB below the prescribed limit. |

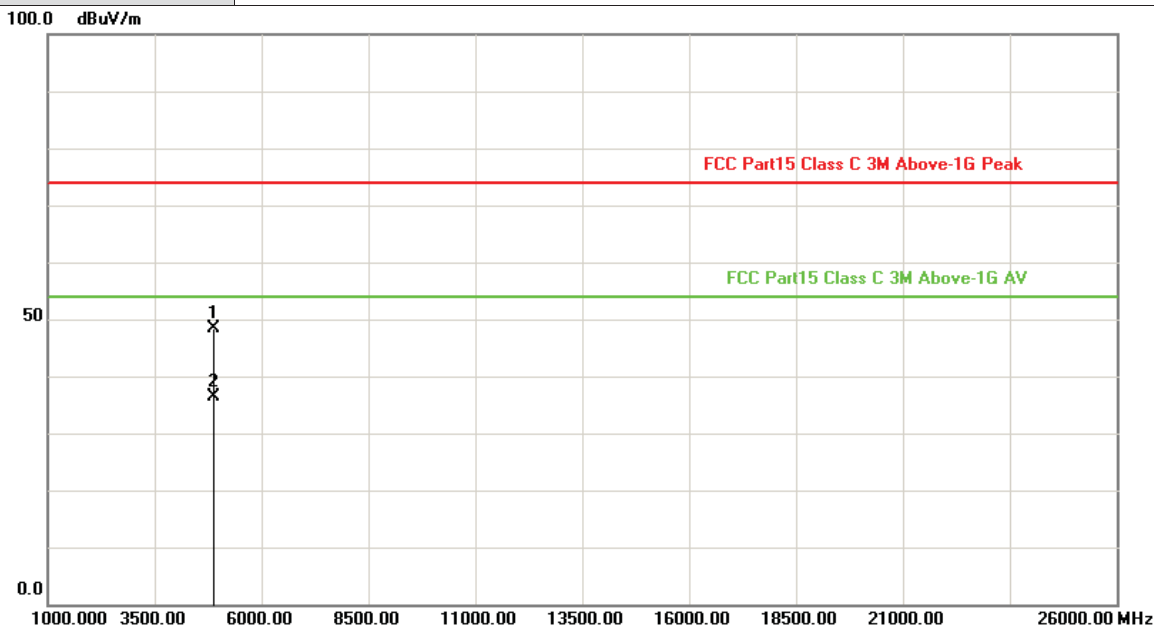

| No. | Frequency (MHz) | Factor (dB/m) | Reading (dBuV) | Level (dBuV/m) | Limit (dBuV/m) | Margin (dB) | Detector |
|-----|-----------------|---------------|----------------|----------------|----------------|-------------|----------|
| 1 | 4873.256 | -2.61 | 50.95 | 48.34 | 74.00 | -25.66 | peak |
| 2 | 4873.910 | -2.61 | 38.93 | 36.32 | 54.00 | -17.68 | AVG |

Remarks:

- 1. Factor (dB/m) = Antenna Factor (dB/m)+Cable Factor (dB)-Pre-amplifier Factor
- 2. Margin value = Level -Limit value



| | |
|-------------------|--|
| Ant. Pol. | Vertical |
| Test Mode: | TX B Mode 2437MHz |
| Remark: | No report for the emission which more than 10 dB below the prescribed limit. |

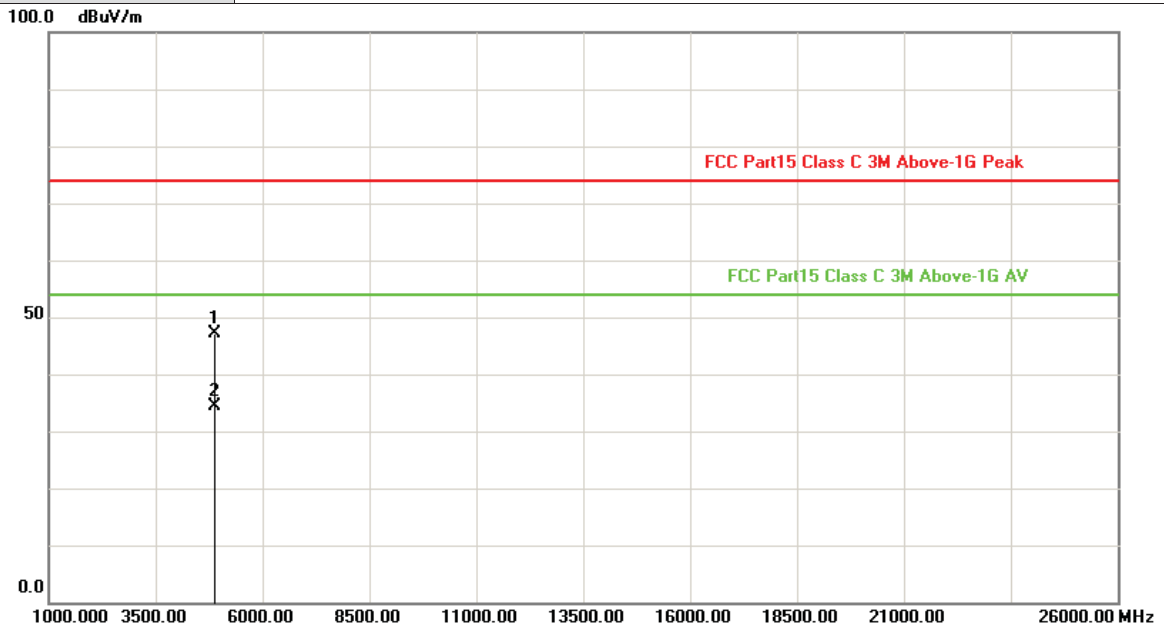

| No. | Frequency (MHz) | Factor (dB/m) | Reading (dBuV) | Level (dBuV/m) | Limit (dBuV/m) | Margin (dB) | Detector |
|-----|-----------------|---------------|----------------|----------------|----------------|-------------|----------|
| 1 | 4874.264 | -2.61 | 49.76 | 47.15 | 74.00 | -26.85 | peak |
| 2 | 4874.030 | -2.61 | 37.02 | 34.41 | 54.00 | -19.59 | AVG |

Remarks:
 1. Factor (dB/m) = Antenna Factor (dB/m)+Cable Factor (dB)-Pre-amplifier Factor
 2. Margin value = Level -Limit value



| | |
|-------------------|--|
| Ant. Pol. | Horizontal |
| Test Mode: | TX B Mode 2462MHz |
| Remark: | No report for the emission which more than 10 dB below the prescribed limit. |

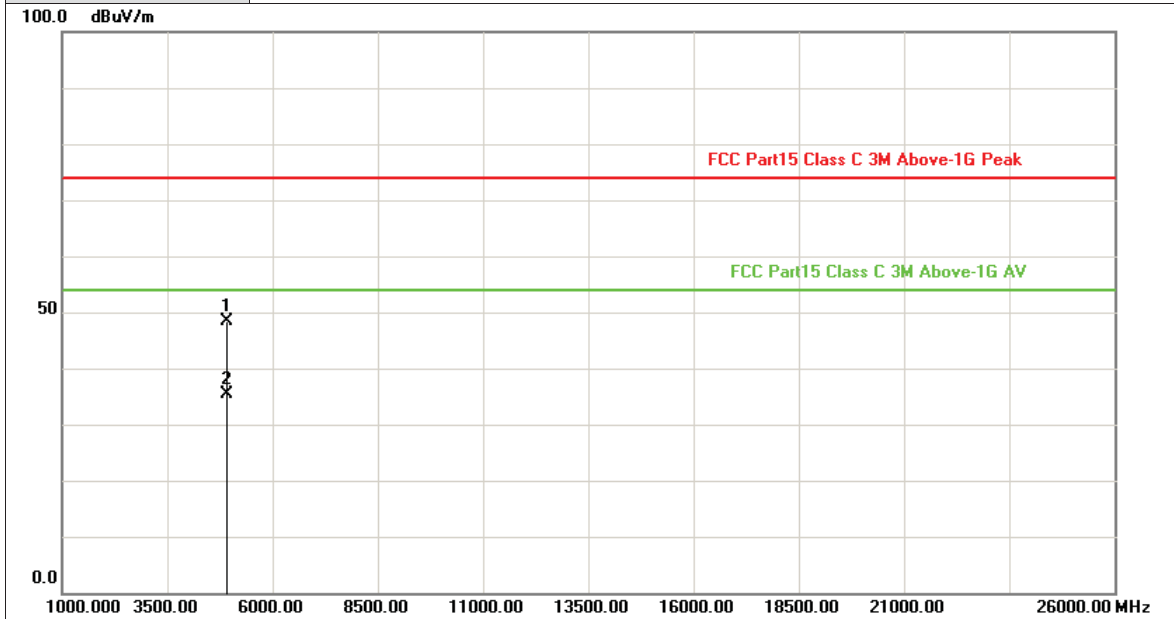

| No. | Frequency (MHz) | Factor (dB/m) | Reading (dBuV) | Level (dBuV/m) | Limit (dBuV/m) | Margin (dB) | Detector |
|-----|-----------------|---------------|----------------|----------------|----------------|-------------|----------|
| 1 | 4924.072 | -2.47 | 50.88 | 48.41 | 74.00 | -25.59 | peak |
| 2 | 4923.895 | -2.47 | 37.94 | 35.47 | 54.00 | -18.53 | AVG |

Remarks:
 1. Factor (dB/m) = Antenna Factor (dB/m)+Cable Factor (dB)-Pre-amplifier Factor
 2. Margin value = Level -Limit value



| | |
|-------------------|--|
| Ant. Pol. | Vertical |
| Test Mode: | TX B Mode 2462MHz |
| Remark: | No report for the emission which more than 10 dB below the prescribed limit. |

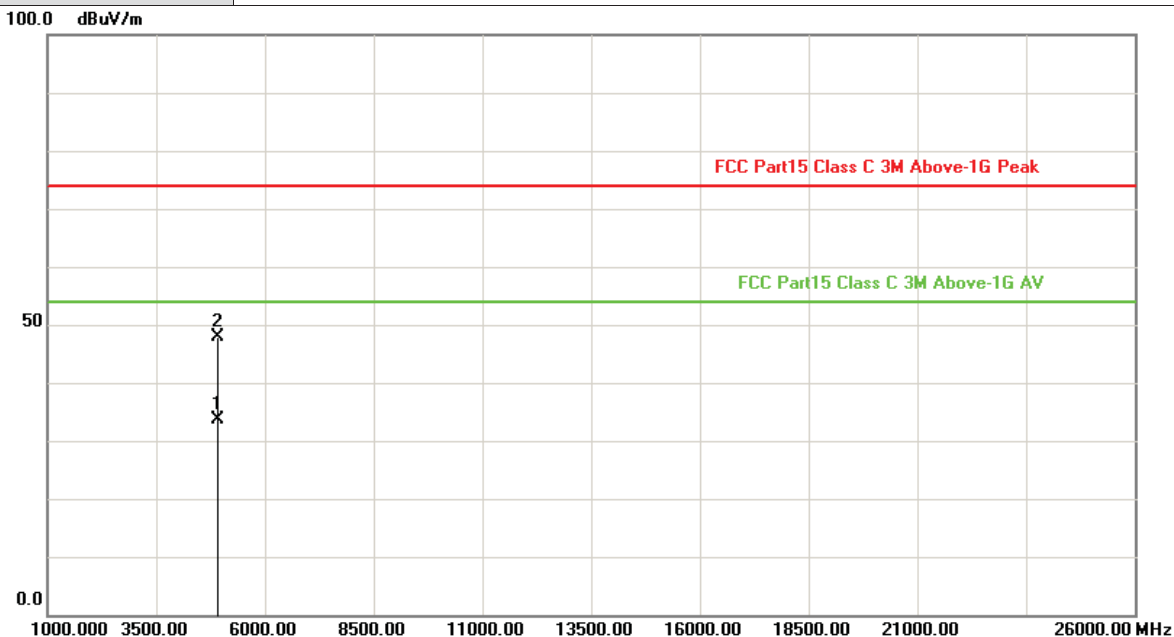

| No. | Frequency (MHz) | Factor (dB/m) | Reading (dBuV) | Level (dBuV/m) | Limit (dBuV/m) | Margin (dB) | Detector |
|-----|-----------------|---------------|----------------|----------------|----------------|-------------|----------|
| 1 | 4923.898 | -2.47 | 36.16 | 33.69 | 54.00 | -20.31 | AVG |
| 2 | 4924.321 | -2.47 | 50.28 | 47.81 | 74.00 | -26.19 | peak |

Remarks:

- Factor (dB/m) = Antenna Factor (dB/m)+Cable Factor (dB)-Pre-amplifier Factor
- Margin value = Level -Limit value



| | |
|------------|--|
| Ant. Pol. | Horizontal |
| Test Mode: | TX G Mode 2412MHz |
| Remark: | No report for the emission which more than 10 dB below the prescribed limit. |

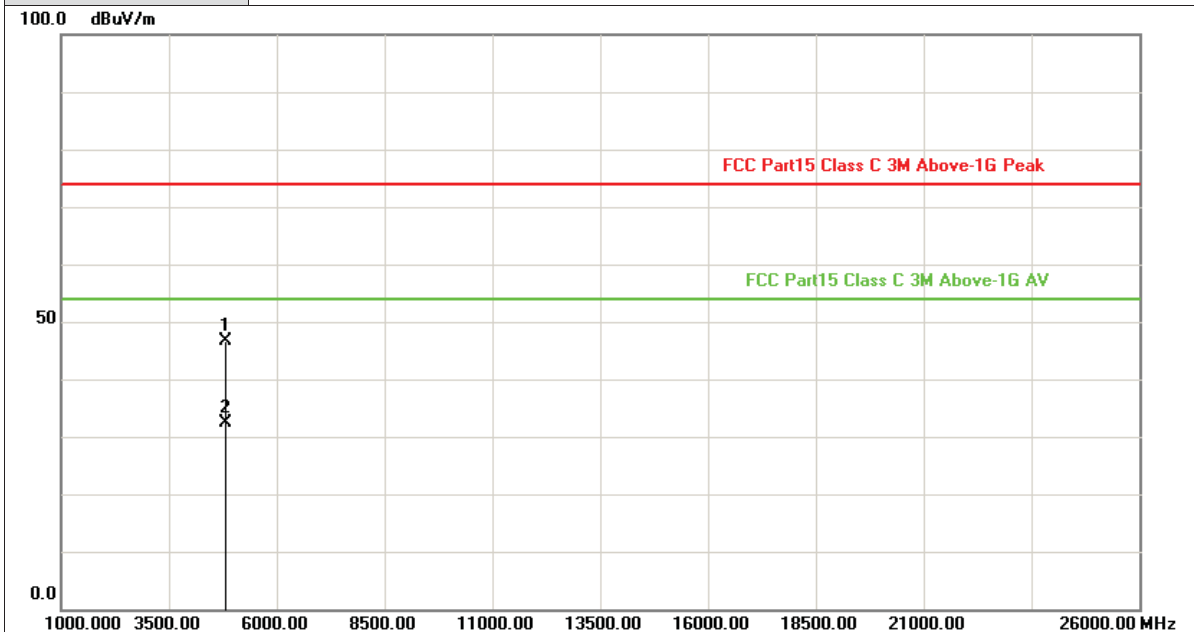

| No. | Frequency (MHz) | Factor (dB/m) | Reading (dBuV) | Level (dBuV/m) | Limit (dBuV/m) | Margin (dB) | Detector |
|-----|-----------------|---------------|----------------|----------------|----------------|-------------|----------|
| 1 | 4823.988 | -2.76 | 49.35 | 46.59 | 74.00 | -27.41 | peak |
| 2 | 4823.079 | -2.76 | 35.10 | 32.34 | 54.00 | -21.66 | AVG |

Remarks:

- Factor (dB/m) = Antenna Factor (dB/m)+Cable Factor (dB)-Pre-amplifier Factor
- Margin value = Level -Limit value



| | |
|-------------------|--|
| Ant. Pol. | Vertical |
| Test Mode: | TX G Mode 2412MHz |
| Remark: | No report for the emission which more than 10 dB below the prescribed limit. |

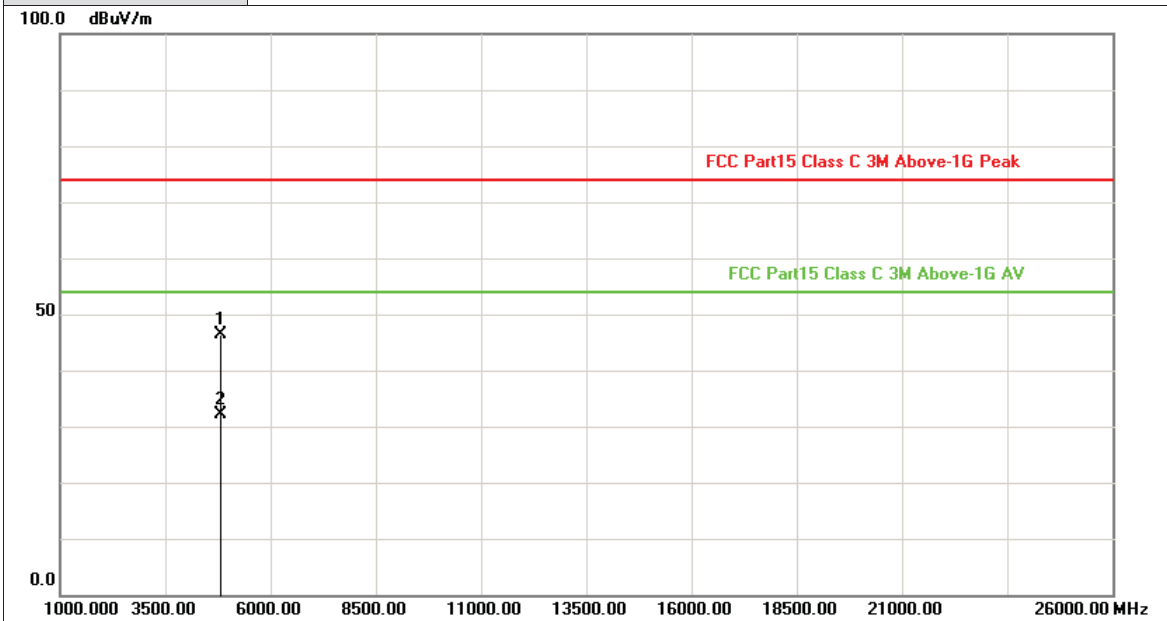

| No. | Frequency (MHz) | Factor (dB/m) | Reading (dBuV) | Level (dBuV/m) | Limit (dBuV/m) | Margin (dB) | Detector |
|-----|-----------------|---------------|----------------|----------------|----------------|-------------|----------|
| 1 | 4824.333 | -2.76 | 49.09 | 46.33 | 74.00 | -27.67 | peak |
| 2 | 4825.008 | -2.76 | 34.84 | 32.08 | 54.00 | -21.92 | AVG |

Remarks:
 1. Factor (dB/m) = Antenna Factor (dB/m)+Cable Factor (dB)-Pre-amplifier Factor
 2. Margin value = Level -Limit value



| | |
|-------------------|--|
| Ant. Pol. | Horizontal |
| Test Mode: | TX G Mode 2437MHz |
| Remark: | No report for the emission which more than 10 dB below the prescribed limit. |

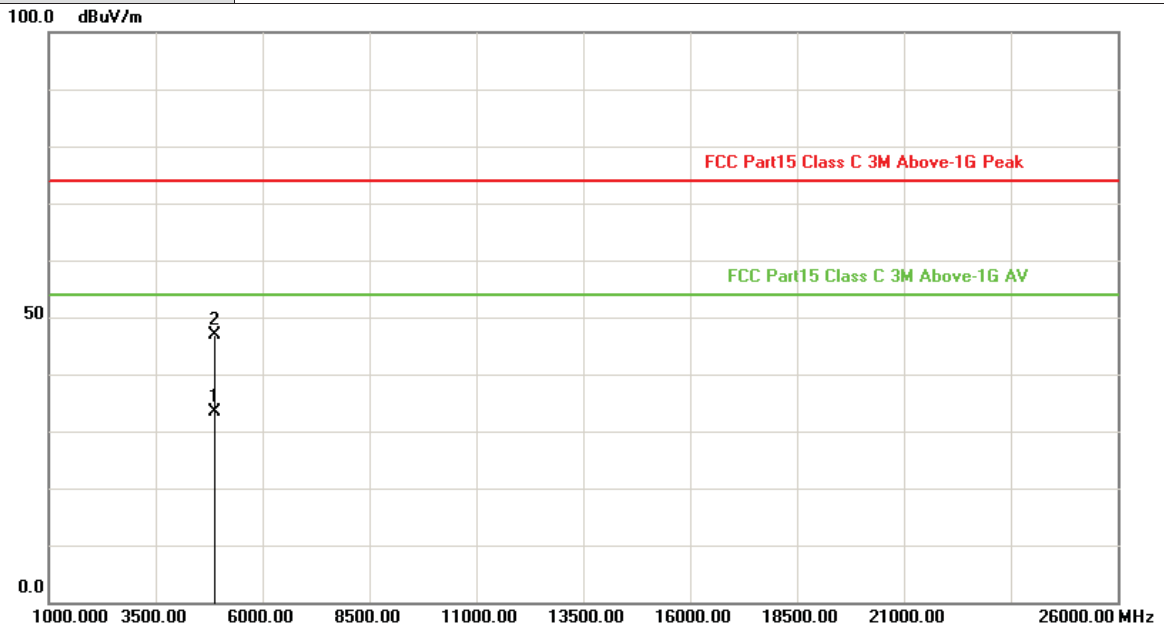

| No. | Frequency (MHz) | Factor (dB/m) | Reading (dBuV) | Level (dBuV/m) | Limit (dBuV/m) | Margin (dB) | Detector |
|-----|-----------------|---------------|----------------|----------------|----------------|-------------|----------|
| 1 | 4875.242 | -2.61 | 35.90 | 33.29 | 54.00 | -20.71 | AVG |
| 2 | 4875.107 | -2.61 | 49.57 | 46.96 | 54.00 | -7.04 | AVG |

Remarks:

- 1. Factor (dB/m) = Antenna Factor (dB/m)+Cable Factor (dB)-Pre-amplifier Factor
- 2. Margin value = Level -Limit value



| | |
|-------------------|--|
| Ant. Pol. | Vertical |
| Test Mode: | TX G Mode 2437MHz |
| Remark: | No report for the emission which more than 10 dB below the prescribed limit. |

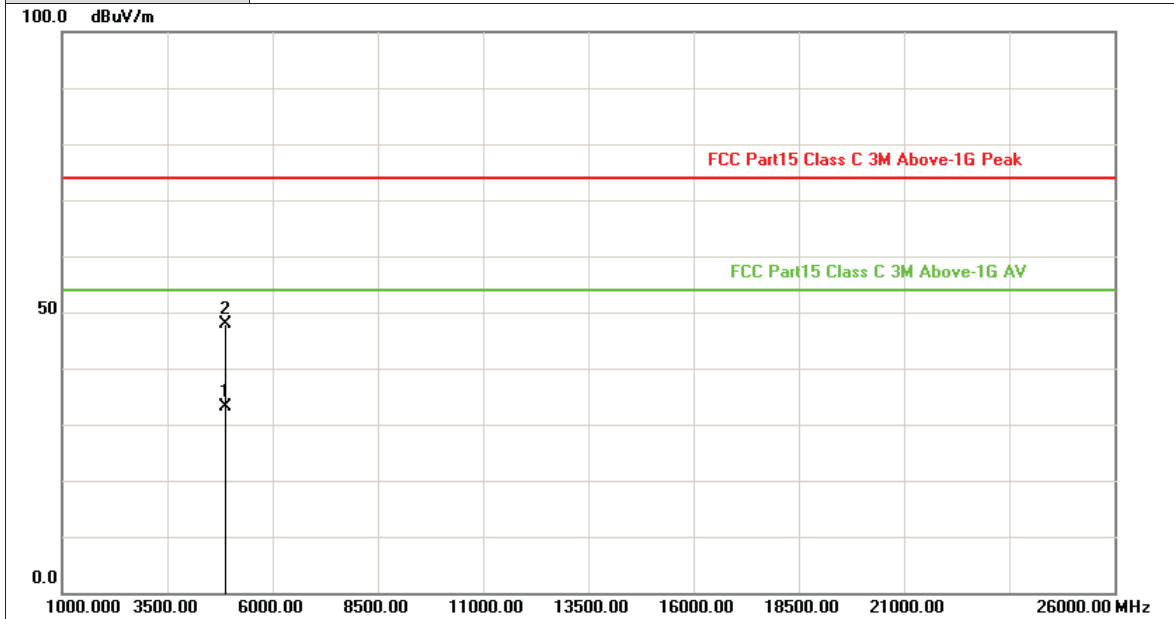

| No. | Frequency (MHz) | Factor (dB/m) | Reading (dBuV) | Level (dBuV/m) | Limit (dBuV/m) | Margin (dB) | Detector |
|-----|-----------------|---------------|----------------|----------------|----------------|-------------|----------|
| 1 | 4874.033 | -2.61 | 35.70 | 33.09 | 54.00 | -20.91 | AVG |
| 2 | 4874.564 | -2.61 | 50.44 | 47.83 | 74.00 | -26.17 | peak |

Remarks:

- Factor (dB/m) = Antenna Factor (dB/m)+Cable Factor (dB)-Pre-amplifier Factor
- Margin value = Level -Limit value



| | |
|-------------------|--|
| Ant. Pol. | Horizontal |
| Test Mode: | TX G Mode 2462MHz |
| Remark: | No report for the emission which more than 10 dB below the prescribed limit. |

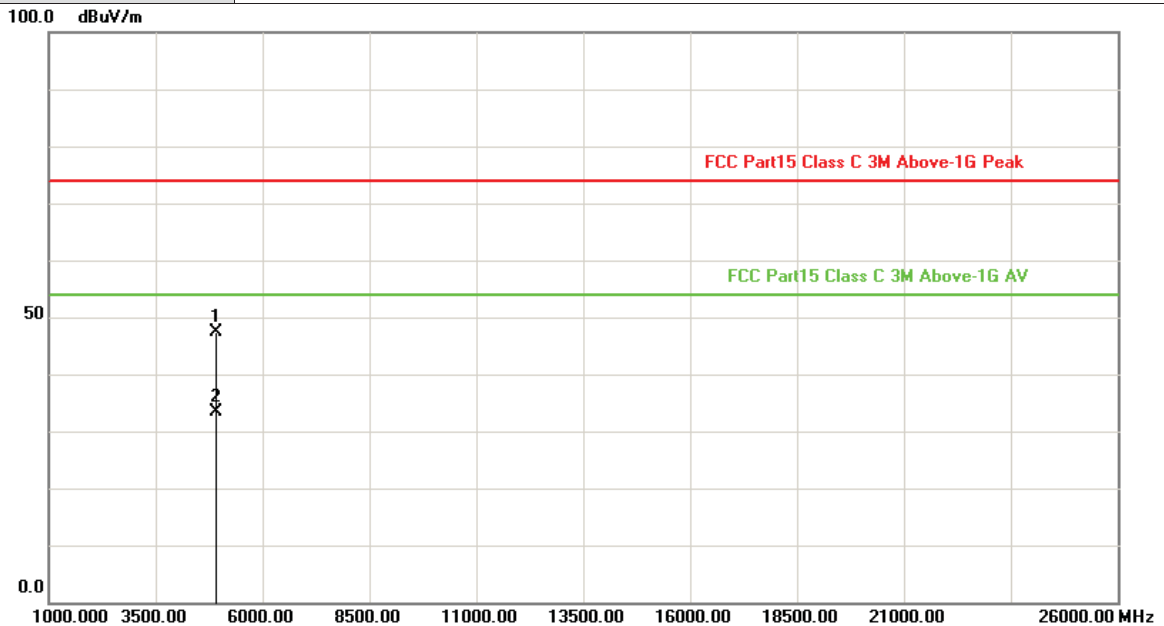

| No. | Frequency (MHz) | Factor (dB/m) | Reading (dBuV) | Level (dBuV/m) | Limit (dBuV/m) | Margin (dB) | Detector |
|-----|-----------------|---------------|----------------|----------------|----------------|-------------|----------|
| 1 | 4923.043 | -2.47 | 49.79 | 47.32 | 74.00 | -26.68 | peak |
| 2 | 4923.343 | -2.47 | 35.78 | 33.31 | 54.00 | -20.69 | AVG |

Remarks:

- 1. Factor (dB/m) = Antenna Factor (dB/m)+Cable Factor (dB)-Pre-amplifier Factor
- 2. Margin value = Level -Limit value



| | |
|-------------------|--|
| Ant. Pol. | Vertical |
| Test Mode: | TX G Mode 2462MHz |
| Remark: | No report for the emission which more than 10 dB below the prescribed limit. |

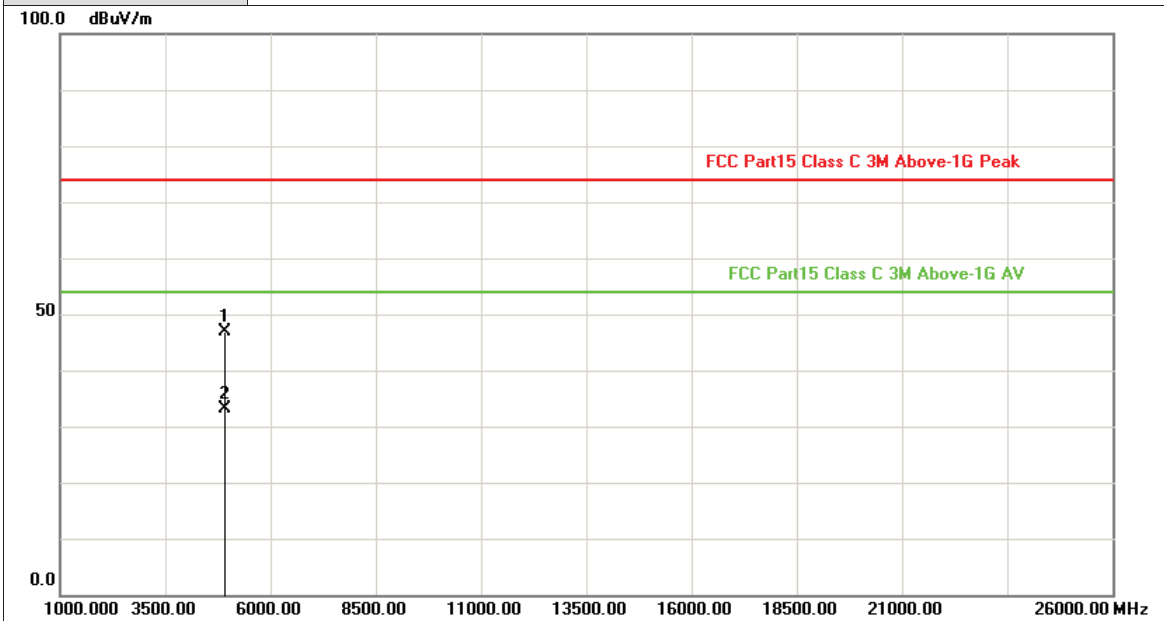

| No. | Frequency (MHz) | Factor (dB/m) | Reading (dBuV) | Level (dBuV/m) | Limit (dBuV/m) | Margin (dB) | Detector |
|-----|-----------------|---------------|----------------|----------------|----------------|-------------|----------|
| 1 | 4922.917 | -2.47 | 49.27 | 46.80 | 74.00 | -27.20 | peak |
| 2 | 4923.424 | -2.47 | 35.65 | 33.18 | 54.00 | -20.82 | AVG |

Remarks:
 1. Factor (dB/m) = Antenna Factor (dB/m)+Cable Factor (dB)-Pre-amplifier Factor
 2. Margin value = Level -Limit value



| | |
|-------------------|--|
| Ant. Pol. | Horizontal |
| Test Mode: | TX N20 Mode 2412MHz |
| Remark: | No report for the emission which more than 10 dB below the prescribed limit. |

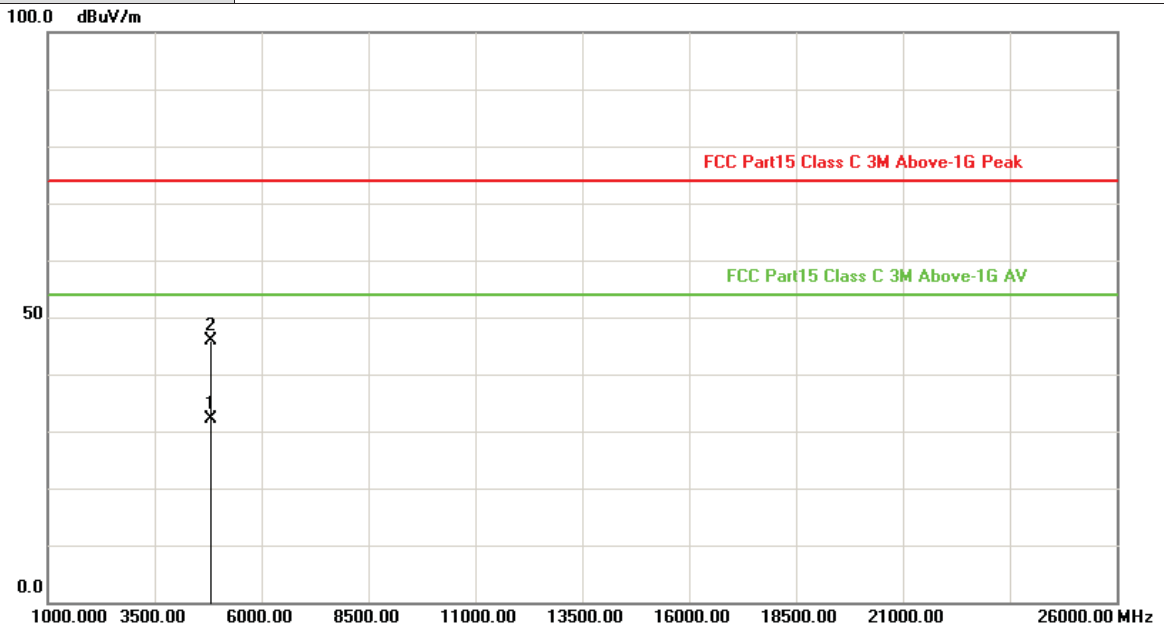

| No. | Frequency (MHz) | Factor (dB/m) | Reading (dBuV) | Level (dBuV/m) | Limit (dBuV/m) | Margin (dB) | Detector |
|-----|-----------------|---------------|----------------|----------------|----------------|-------------|----------|
| 1 | 4823.682 | -2.76 | 34.88 | 32.12 | 54.00 | -21.88 | AVG |
| 2 | 4823.574 | -2.76 | 48.60 | 45.84 | 74.00 | -28.16 | peak |

Remarks:

- Factor (dB/m) = Antenna Factor (dB/m)+Cable Factor (dB)-Pre-amplifier Factor
- Margin value = Level -Limit value



| | |
|-------------------|--|
| Ant. Pol. | Vertical |
| Test Mode: | TX N20 Mode 2412MHz |
| Remark: | No report for the emission which more than 10 dB below the prescribed limit. |

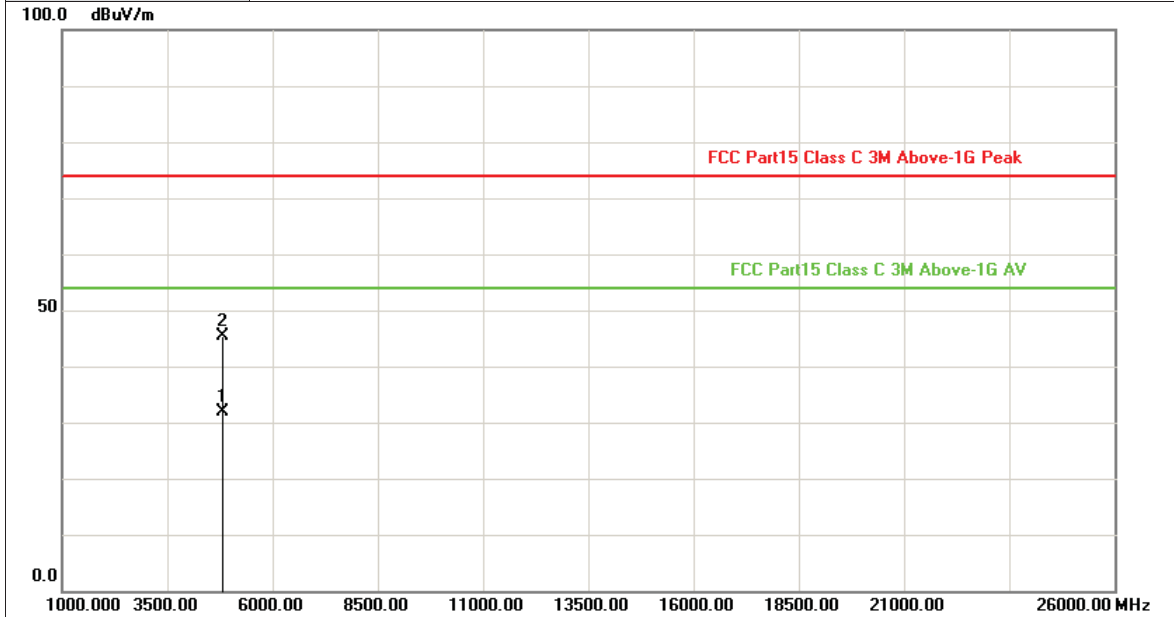

| No. | Frequency (MHz) | Factor (dB/m) | Reading (dBuV) | Level (dBuV/m) | Limit (dBuV/m) | Margin (dB) | Detector |
|-----|-----------------|---------------|----------------|----------------|----------------|-------------|----------|
| 1 | 4823.802 | -2.76 | 34.54 | 31.78 | 54.00 | -22.22 | AVG |
| 2 | 4824.420 | -2.76 | 48.05 | 45.29 | 74.00 | -28.71 | peak |

Remarks:
 1. Factor (dB/m) = Antenna Factor (dB/m)+Cable Factor (dB)-Pre-amplifier Factor
 2. Margin value = Level -Limit value



| | |
|-------------------|--|
| Ant. Pol. | Horizontal |
| Test Mode: | TX N20 Mode 2437MHz |
| Remark: | No report for the emission which more than 10 dB below the prescribed limit. |

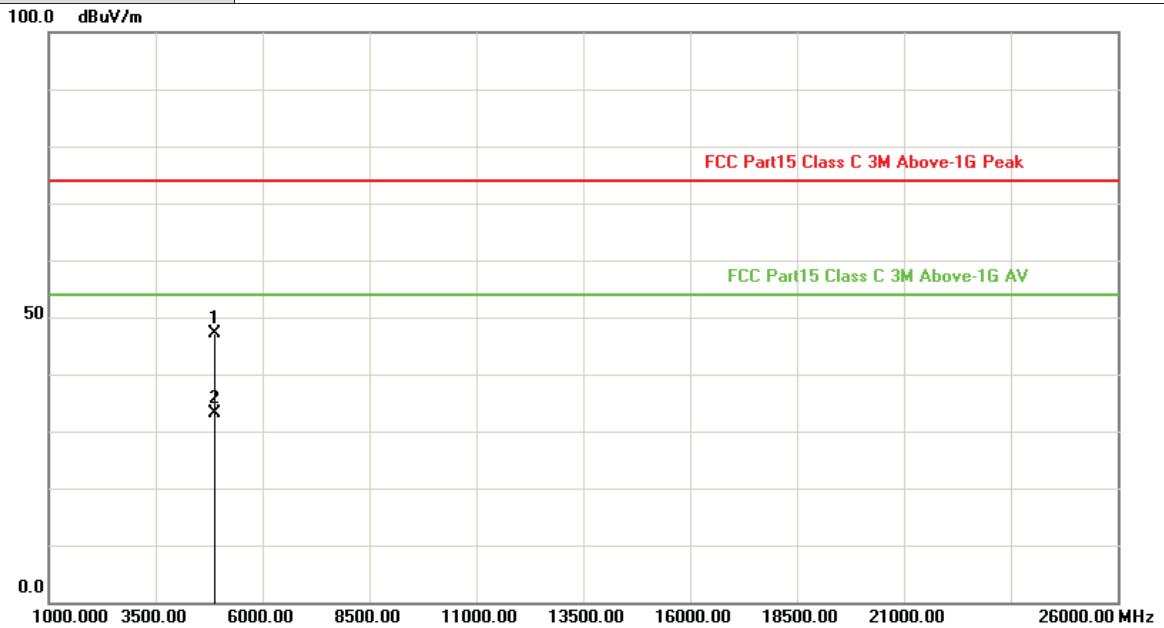

| No. | Frequency (MHz) | Factor (dB/m) | Reading (dBuV) | Level (dBuV/m) | Limit (dBuV/m) | Margin (dB) | Detector |
|-----|-----------------|---------------|----------------|----------------|----------------|-------------|----------|
| 1 | 4874.315 | -2.61 | 49.84 | 47.23 | 74.00 | -26.77 | peak |
| 2 | 4874.162 | -2.61 | 35.63 | 33.02 | 54.00 | -20.98 | AVG |

Remarks:

- 1. Factor (dB/m) = Antenna Factor (dB/m)+Cable Factor (dB)-Pre-amplifier Factor
- 2. Margin value = Level -Limit value



| | |
|-------------------|--|
| Ant. Pol. | Vertical |
| Test Mode: | TX N20 Mode 2437MHz |
| Remark: | No report for the emission which more than 10 dB below the prescribed limit. |

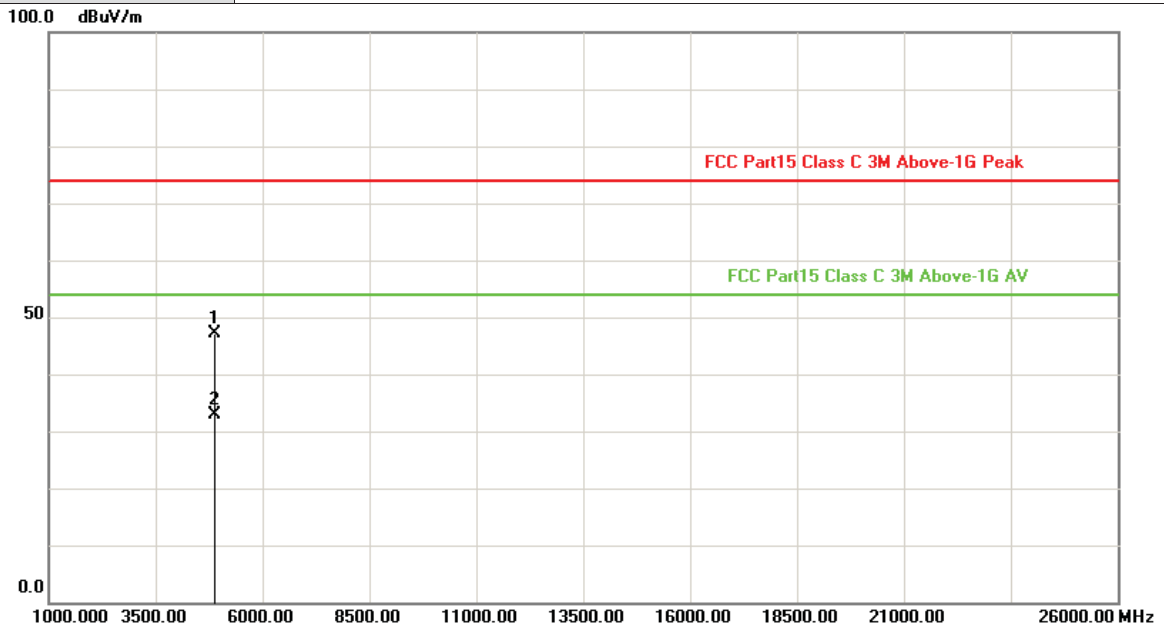

| No. | Frequency (MHz) | Factor (dB/m) | Reading (dBuV) | Level (dBuV/m) | Limit (dBuV/m) | Margin (dB) | Detector |
|-----|-----------------|---------------|----------------|----------------|----------------|-------------|----------|
| 1 | 4873.097 | -2.61 | 49.75 | 47.14 | 74.00 | -26.86 | peak |
| 2 | 4873.292 | -2.61 | 35.54 | 32.93 | 54.00 | -21.07 | AVG |

Remarks:

- Factor (dB/m) = Antenna Factor (dB/m)+Cable Factor (dB)-Pre-amplifier Factor
- Margin value = Level -Limit value



| | |
|-------------------|--|
| Ant. Pol. | Horizontal |
| Test Mode: | TX N20 Mode 2462MHz |
| Remark: | No report for the emission which more than 10 dB below the prescribed limit. |

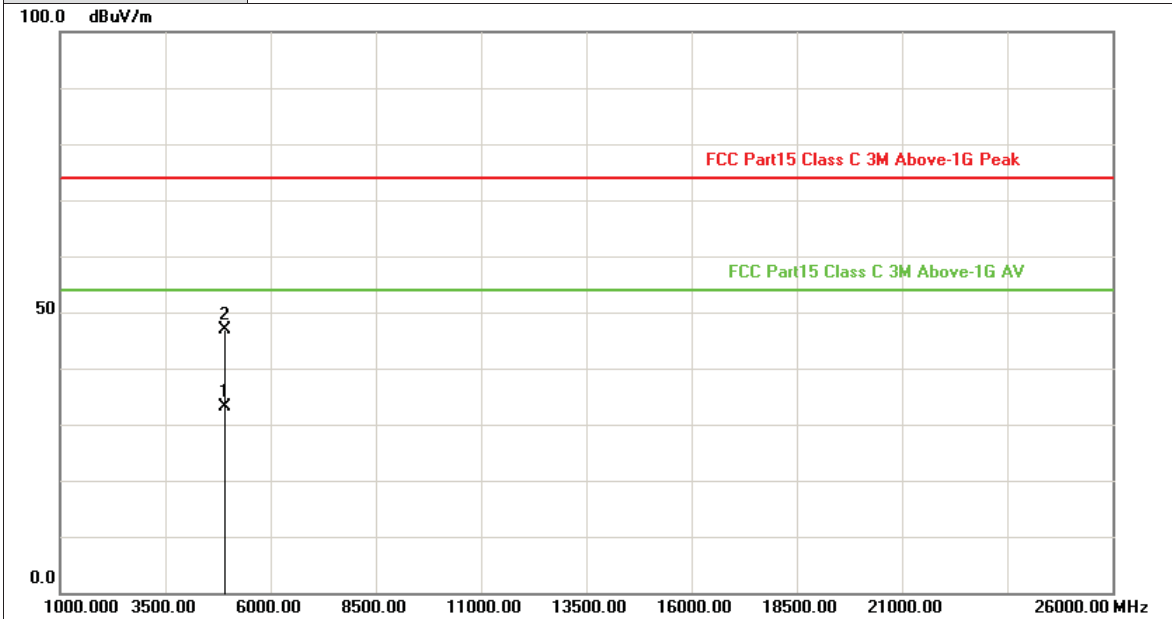

| No. | Frequency (MHz) | Factor (dB/m) | Reading (dBuV) | Level (dBuV/m) | Limit (dBuV/m) | Margin (dB) | Detector |
|-----|-----------------|---------------|----------------|----------------|----------------|-------------|----------|
| 1 | 4924.309 | -2.47 | 35.70 | 33.23 | 54.00 | -20.77 | AVG |
| 2 | 4923.631 | -2.47 | 49.44 | 46.97 | 74.00 | -27.03 | peak |

Remarks:
 1. Factor (dB/m) = Antenna Factor (dB/m)+Cable Factor (dB)-Pre-amplifier Factor
 2. Margin value = Level -Limit value



| | |
|-------------------|--|
| Ant. Pol. | Vertical |
| Test Mode: | TX N20 Mode 2462MHz |
| Remark: | No report for the emission which more than 10 dB below the prescribed limit. |

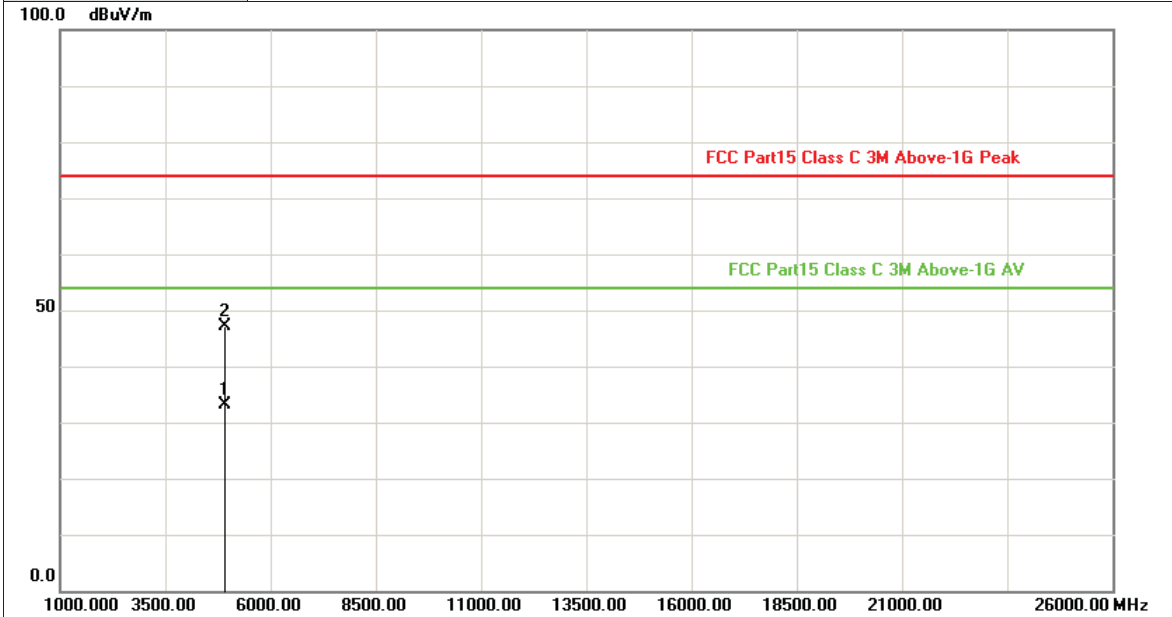

| No. | Frequency (MHz) | Factor (dB/m) | Reading (dBuV) | Level (dBuV/m) | Limit (dBuV/m) | Margin (dB) | Detector |
|-----|-----------------|---------------|----------------|----------------|----------------|-------------|----------|
| 1 | 4924.468 | -2.47 | 35.60 | 33.13 | 54.00 | -20.87 | AVG |
| 2 | 4924.417 | -2.47 | 49.60 | 47.13 | 74.00 | -26.87 | peak |

Remarks:
 1. Factor (dB/m) = Antenna Factor (dB/m)+Cable Factor (dB)-Pre-amplifier Factor
 2. Margin value = Level -Limit value



| | |
|------------|--|
| Ant. Pol. | Horizontal |
| Test Mode: | TX N40 Mode 2422MHz |
| Remark: | No report for the emission which more than 10 dB below the prescribed limit. |

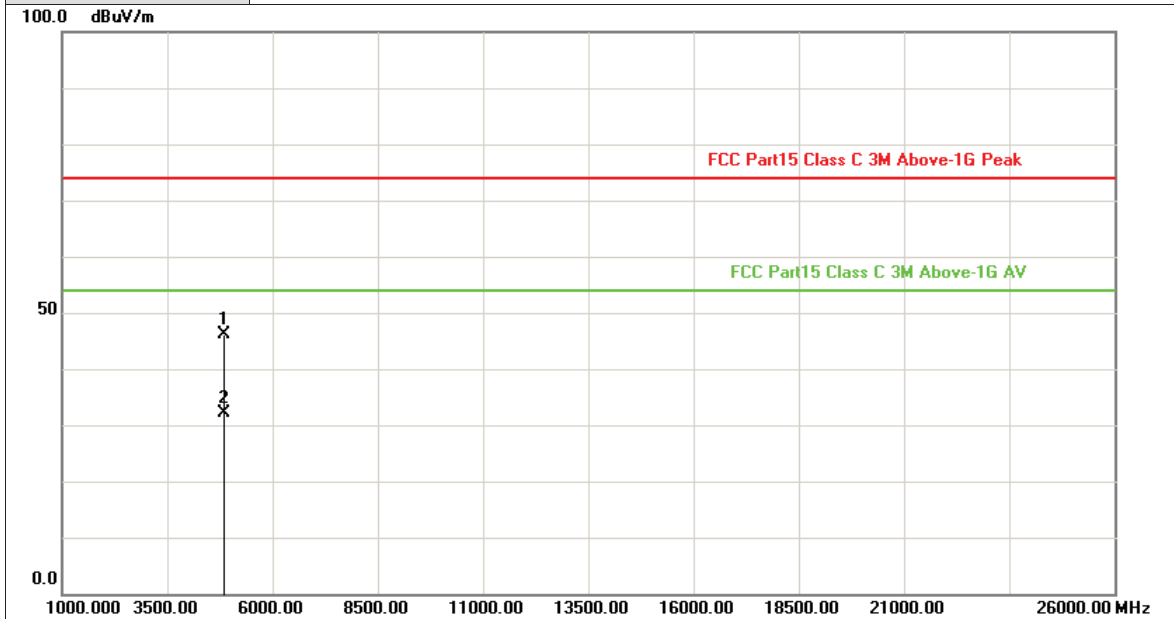

| No. | Frequency (MHz) | Factor (dB/m) | Reading (dBuV) | Level (dBuV/m) | Limit (dBuV/m) | Margin (dB) | Detector |
|-----|-----------------|---------------|----------------|----------------|----------------|-------------|----------|
| 1 | 4843.943 | -2.70 | 48.77 | 46.07 | 74.00 | -27.93 | peak |
| 2 | 4844.696 | -2.70 | 34.84 | 32.14 | 54.00 | -21.86 | AVG |

Remarks:

- Factor (dB/m) = Antenna Factor (dB/m)+Cable Factor (dB)-Pre-amplifier Factor
- Margin value = Level -Limit value



| | |
|-------------------|--|
| Ant. Pol. | Vertical |
| Test Mode: | TX N40 Mode 2422MHz |
| Remark: | No report for the emission which more than 10 dB below the prescribed limit. |

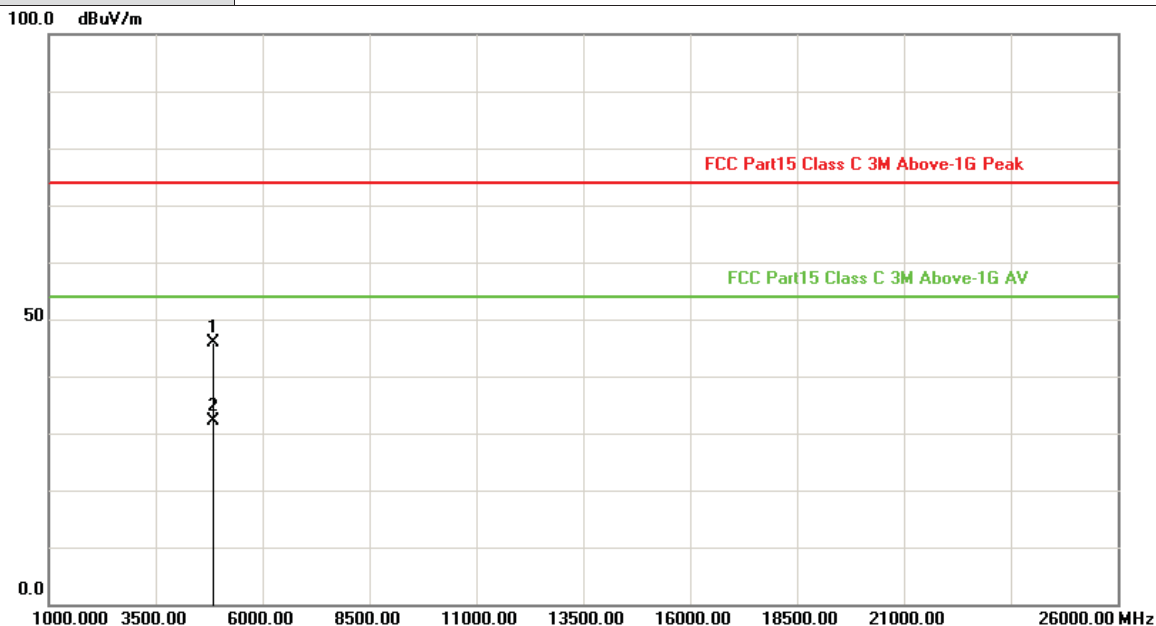

| No. | Frequency (MHz) | Factor (dB/m) | Reading (dBuV) | Level (dBuV/m) | Limit (dBuV/m) | Margin (dB) | Detector |
|-----|-----------------|---------------|----------------|----------------|----------------|-------------|----------|
| 1 | 4843.835 | -2.70 | 48.48 | 45.78 | 74.00 | -28.22 | peak |
| 2 | 4843.850 | -2.70 | 34.78 | 32.08 | 54.00 | -21.92 | AVG |

Remarks:

- 1. Factor (dB/m) = Antenna Factor (dB/m)+Cable Factor (dB)-Pre-amplifier Factor
- 2. Margin value = Level -Limit value



| | |
|-------------------|--|
| Ant. Pol. | Horizontal |
| Test Mode: | TX N40 Mode 2437MHz |
| Remark: | No report for the emission which more than 10 dB below the prescribed limit. |

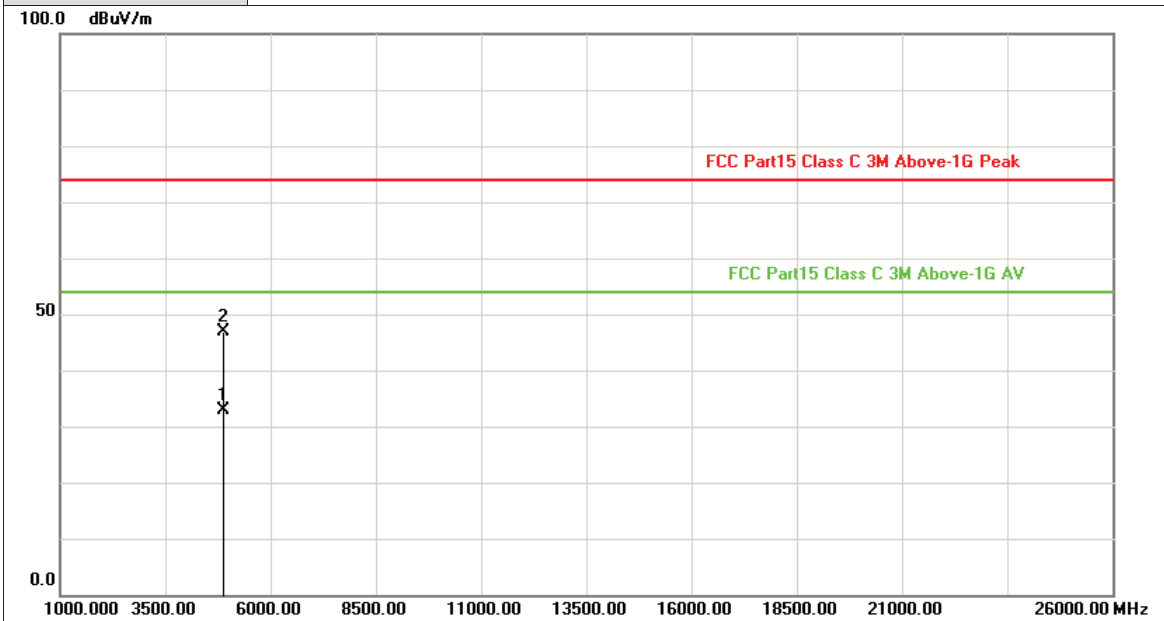

| No. | Frequency (MHz) | Factor (dB/m) | Reading (dBuV) | Level (dBuV/m) | Limit (dBuV/m) | Margin (dB) | Detector |
|-----|-----------------|---------------|----------------|----------------|----------------|-------------|----------|
| 1 | 4874.249 | -2.61 | 35.61 | 33.00 | 54.00 | -21.00 | AVG |
| 2 | 4874.942 | -2.61 | 49.37 | 46.76 | 74.00 | -27.24 | peak |

Remarks:
 1. Factor (dB/m) = Antenna Factor (dB/m)+Cable Factor (dB)-Pre-amplifier Factor
 2. Margin value = Level -Limit value



| | |
|-------------------|--|
| Ant. Pol. | Vertical |
| Test Mode: | TX N40 Mode 2437MHz |
| Remark: | No report for the emission which more than 10 dB below the prescribed limit. |

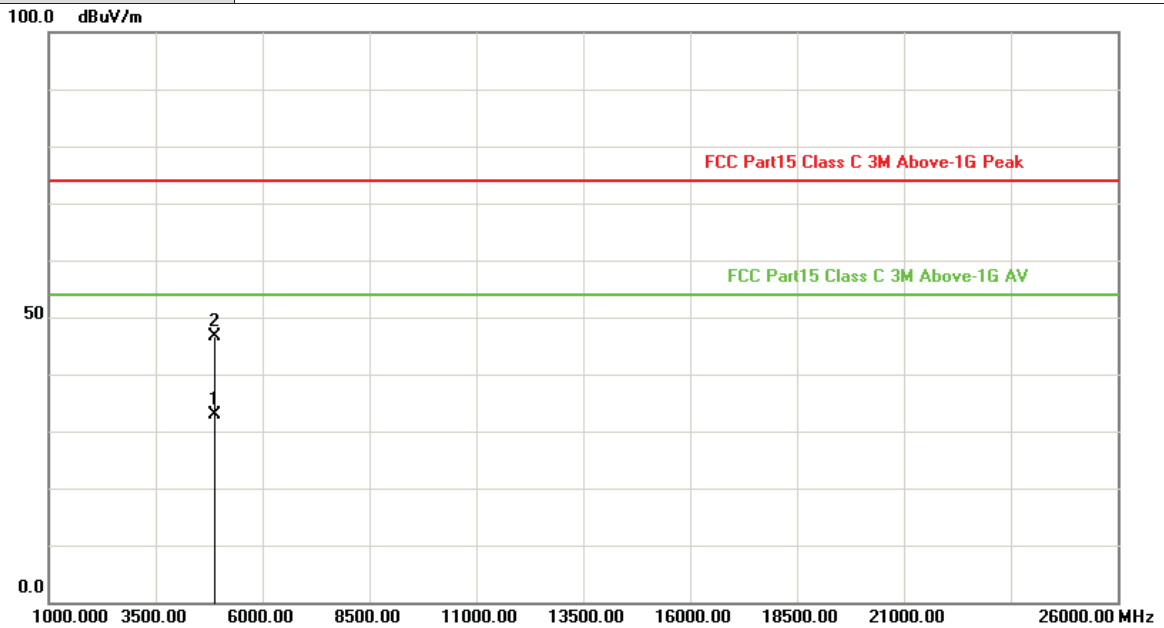

| No. | Frequency (MHz) | Factor (dB/m) | Reading (dBuV) | Level (dBuV/m) | Limit (dBuV/m) | Margin (dB) | Detector |
|-----|-----------------|---------------|----------------|----------------|----------------|-------------|----------|
| 1 | 4873.655 | -2.61 | 35.46 | 32.85 | 54.00 | -21.15 | AVG |
| 2 | 4873.358 | -2.61 | 49.24 | 46.63 | 74.00 | -27.37 | peak |

Remarks:
 1. Factor (dB/m) = Antenna Factor (dB/m)+Cable Factor (dB)-Pre-amplifier Factor
 2. Margin value = Level -Limit value



| | |
|-------------------|--|
| Ant. Pol. | Horizontal |
| Test Mode: | TX N40 Mode 2452MHz |
| Remark: | No report for the emission which more than 10 dB below the prescribed limit. |

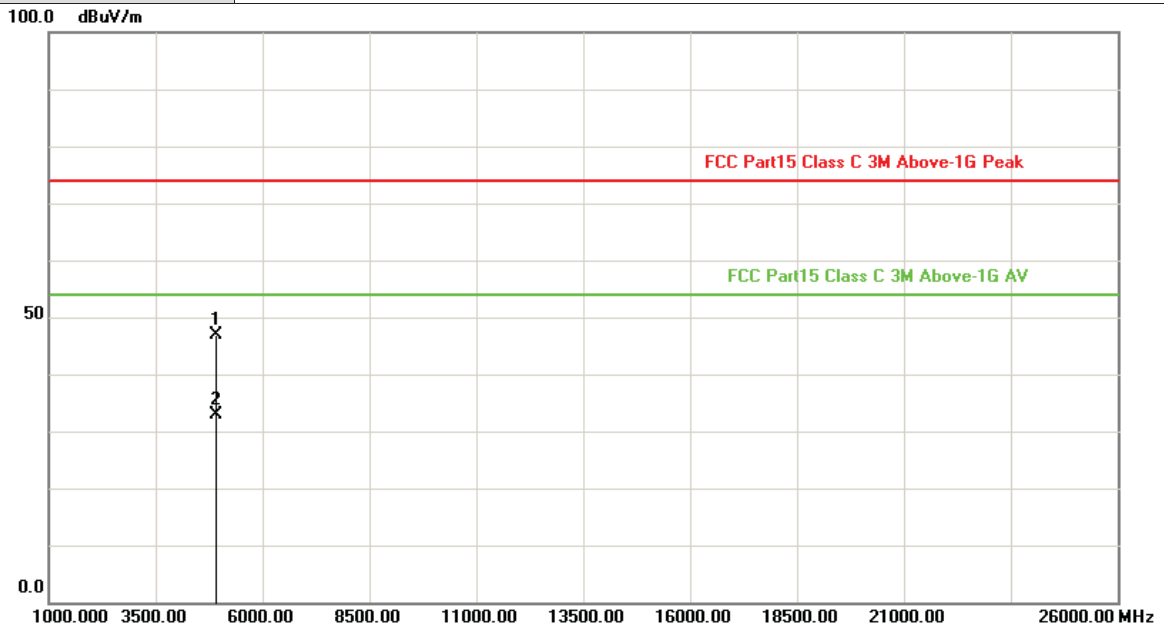

| No. | Frequency (MHz) | Factor (dB/m) | Reading (dBuV) | Level (dBuV/m) | Limit (dBuV/m) | Margin (dB) | Detector |
|-----|-----------------|---------------|----------------|----------------|----------------|-------------|----------|
| 1 | 4902.890 | -2.53 | 49.31 | 46.78 | 74.00 | -27.22 | peak |
| 2 | 4903.796 | -2.53 | 35.34 | 32.81 | 54.00 | -21.19 | AVG |

Remarks:

- 1. Factor (dB/m) = Antenna Factor (dB/m)+Cable Factor (dB)-Pre-amplifier Factor
- 2. Margin value = Level -Limit value



| | |
|-------------------|--|
| Ant. Pol. | Vertical |
| Test Mode: | TX N40 Mode 2452MHz |
| Remark: | No report for the emission which more than 10 dB below the prescribed limit. |

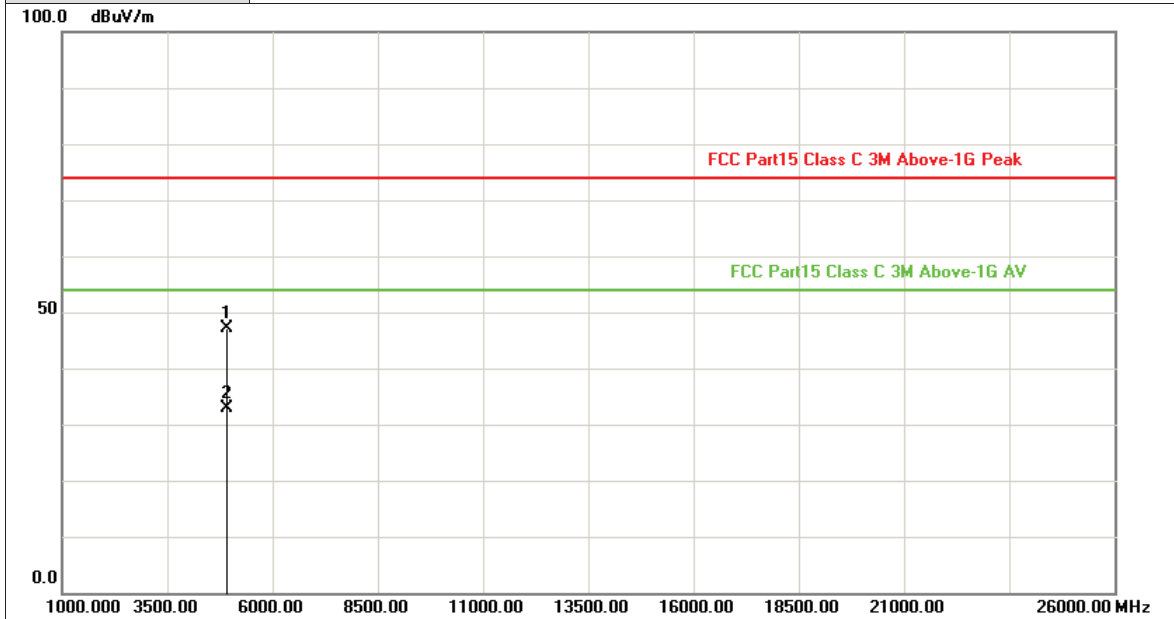

| No. | Frequency (MHz) | Factor (dB/m) | Reading (dBuV) | Level (dBuV/m) | Limit (dBuV/m) | Margin (dB) | Detector |
|-----|-----------------|---------------|----------------|----------------|----------------|-------------|----------|
| 1 | 4903.850 | -2.53 | 49.67 | 47.14 | 74.00 | -26.86 | peak |
| 2 | 4903.037 | -2.53 | 35.34 | 32.81 | 54.00 | -21.19 | AVG |

Remarks:
 1. Factor (dB/m) = Antenna Factor (dB/m)+Cable Factor (dB)-Pre-amplifier Factor
 2. Margin value = Level -Limit value



Conducted Emission data:

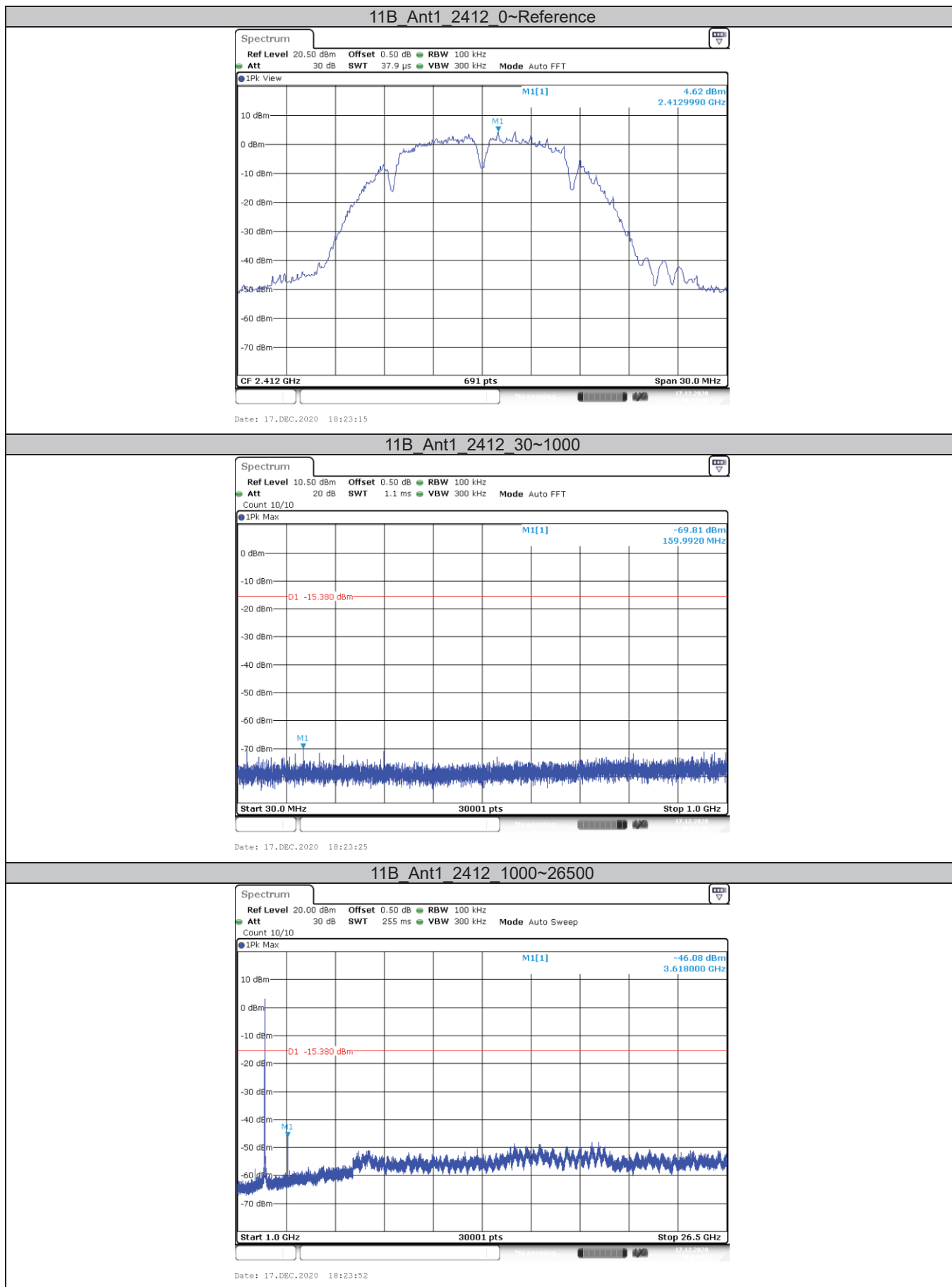

CTC Laboratories, Inc.

1-2/F., Building 2, Jiaquan Building, Guanlan High-Tech Park, Shenzhen, Guangdong, China
Tel.: (86)755-27521059

Fax: (86)755-27521011 Http://www.sz-ctc.org.cn



For anti-fake verification, please visit the official website of Certification and Accreditation Administration of the People's Republic of China : yz.cnca.cn

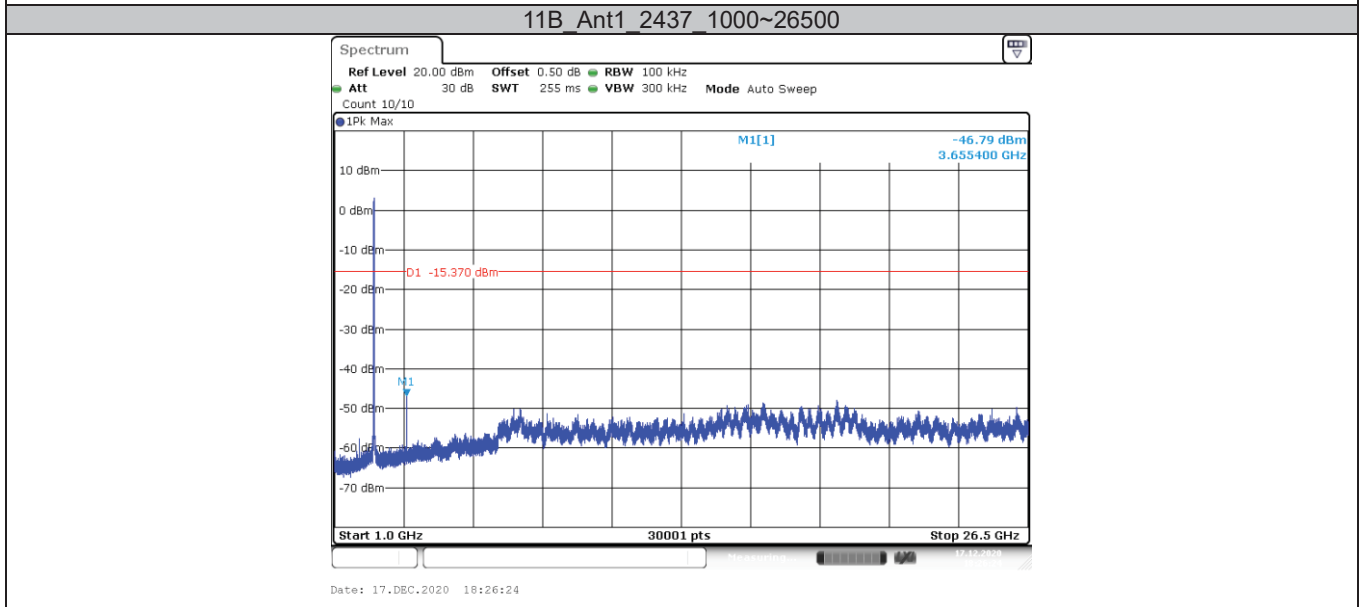
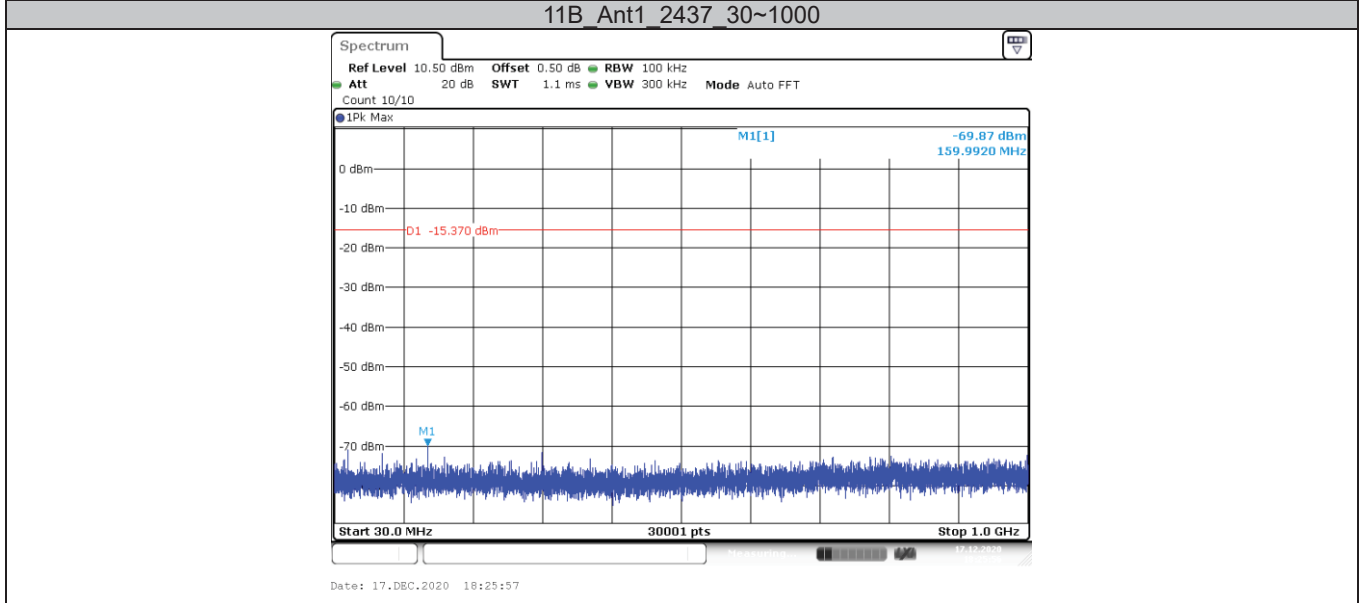
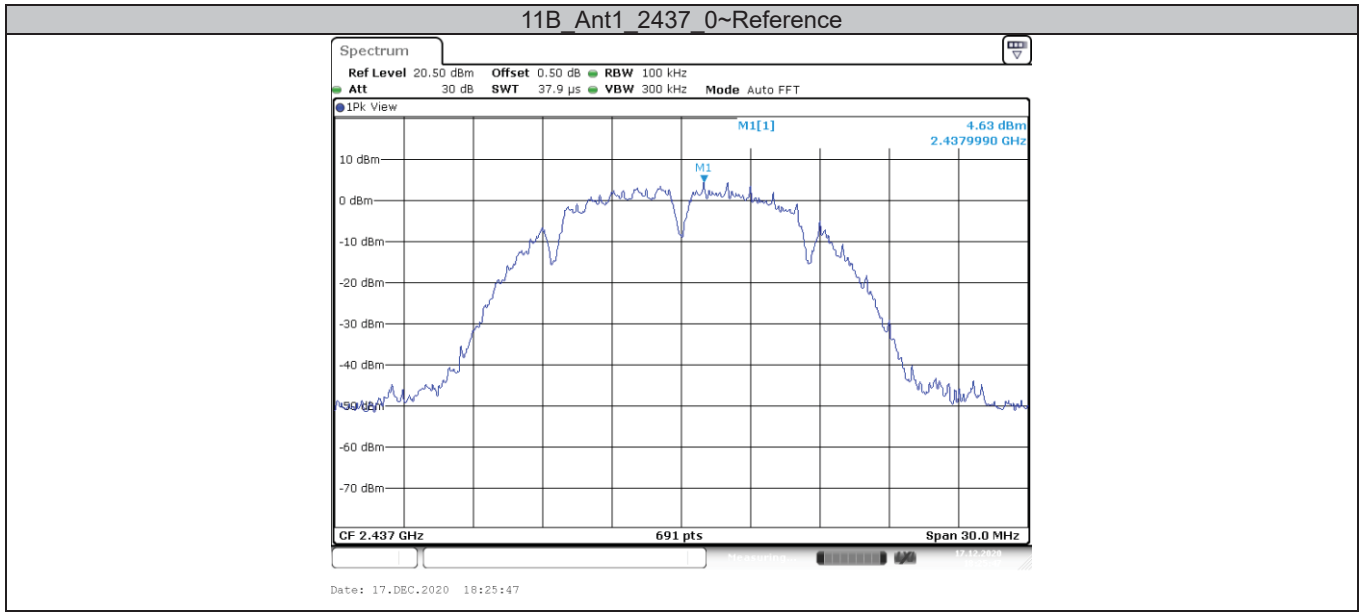

CTC Laboratories, Inc.

1-2/F., Building 2, Jiaquan Building, Guanlan High-Tech Park, Shenzhen, Guangdong, China
 Tel.: (86)755-27521059 Fax: (86)755-27521011 Http://www.sz-ctc.org.cn



For anti-fake verification, please visit the official website of Certification and Accreditation Administration of the People's Republic of China : yz.cnca.cn

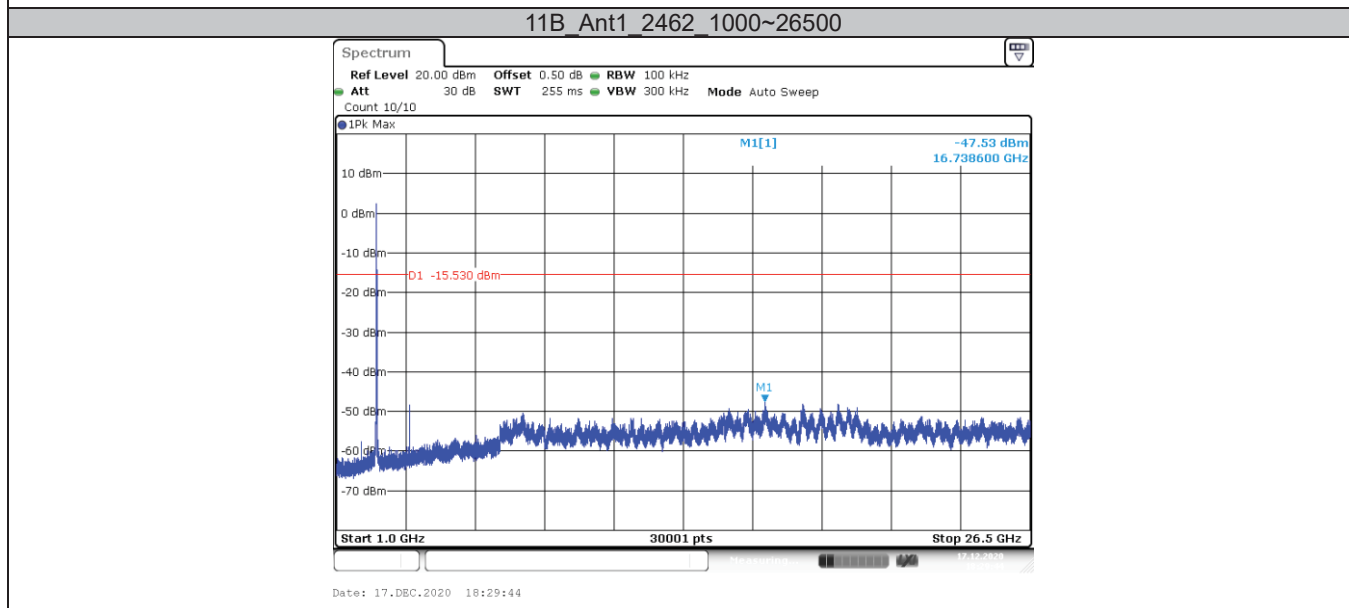
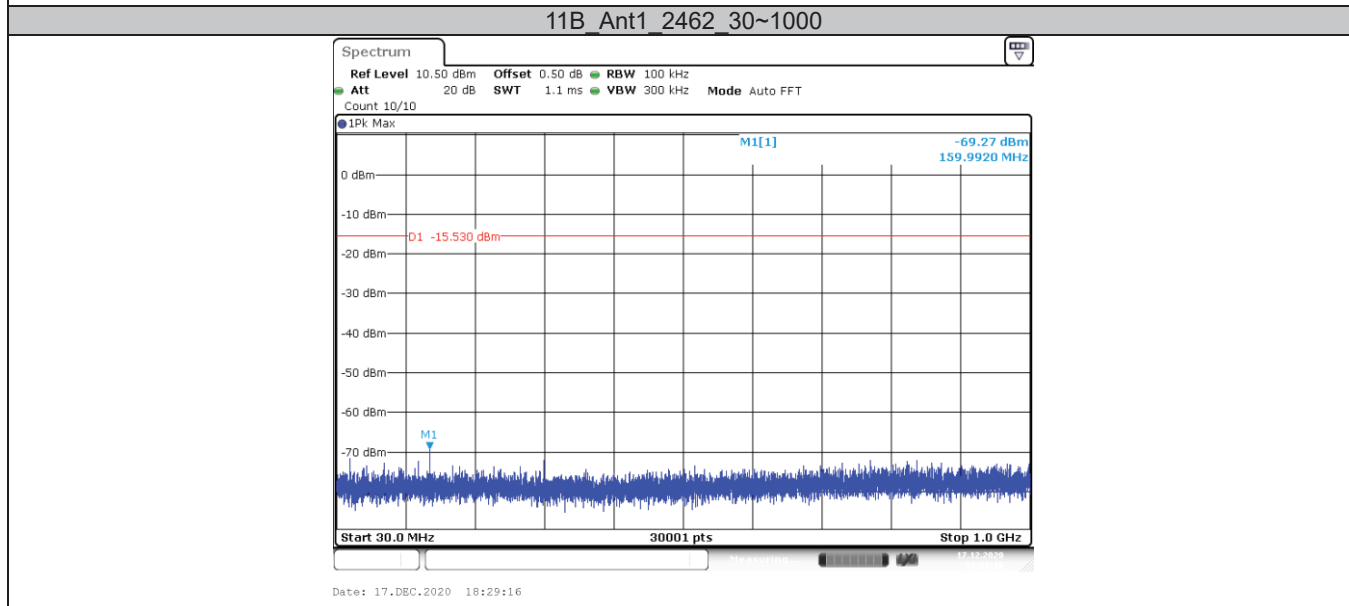
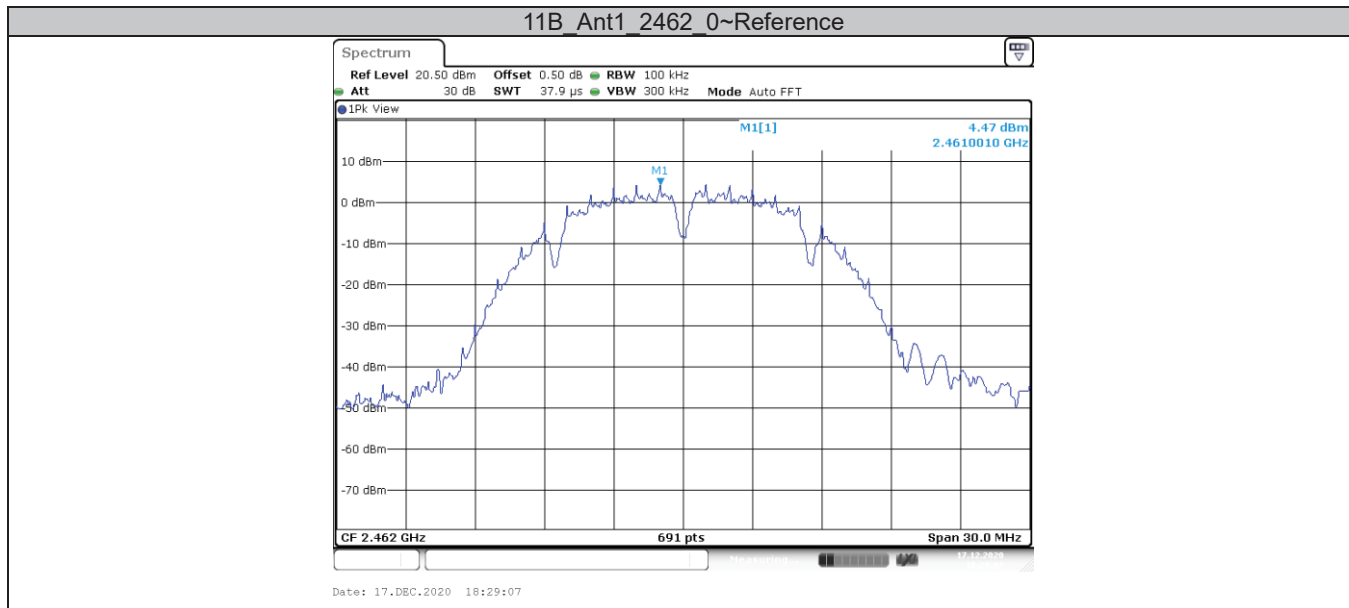

CTC Laboratories, Inc.

1-2/F., Building 2, Jiaquan Building, Guanlan High-Tech Park, Shenzhen, Guangdong, China
Tel.: (86)755-27521059 Fax: (86)755-27521011 Http://www.sz-ctc.org.cn



For anti-fake verification, please visit the official website of Certification and Accreditation Administration of the People's Republic of China : yz.cnca.cn

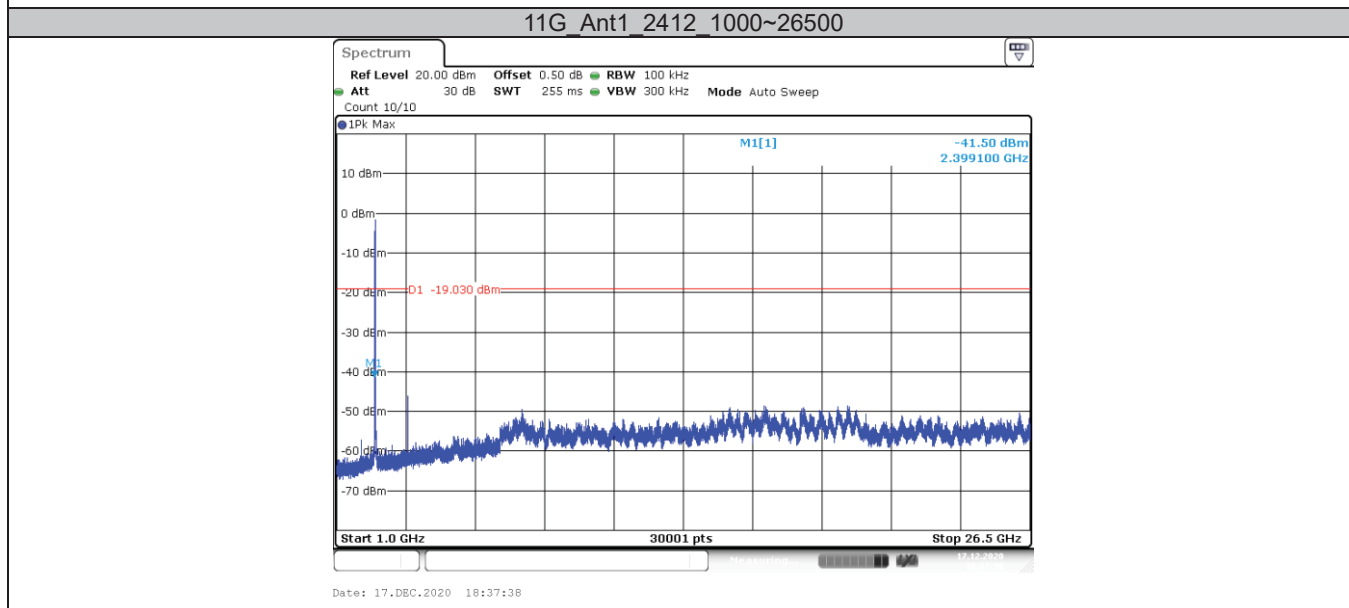
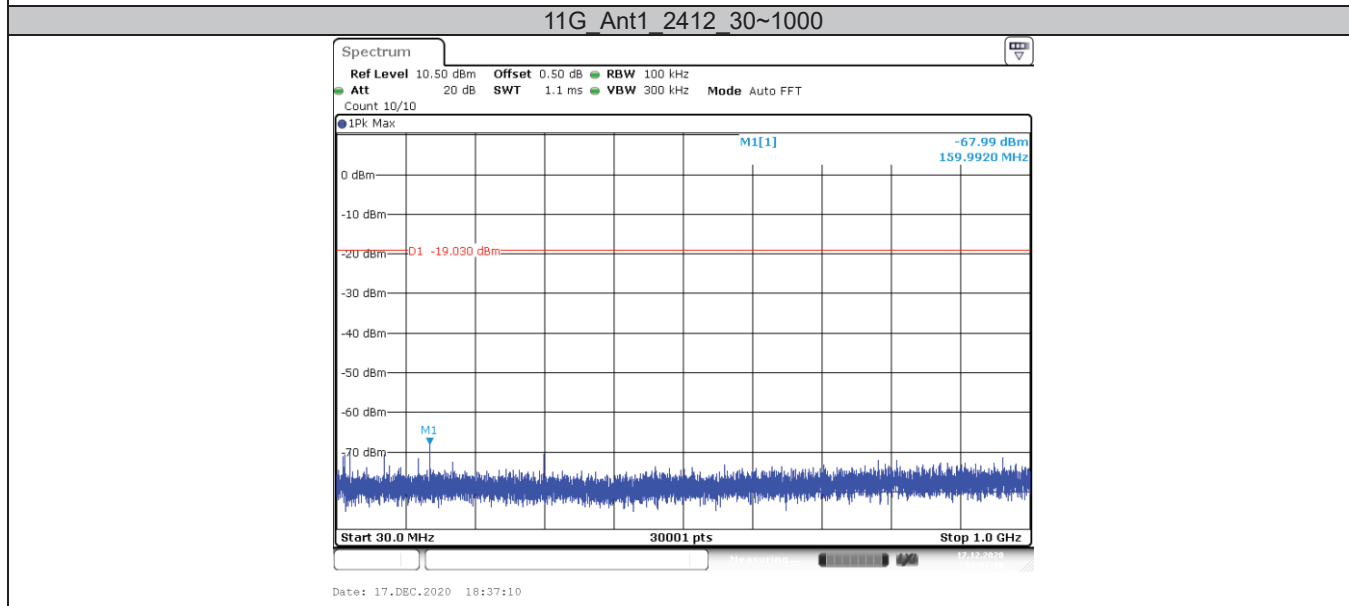
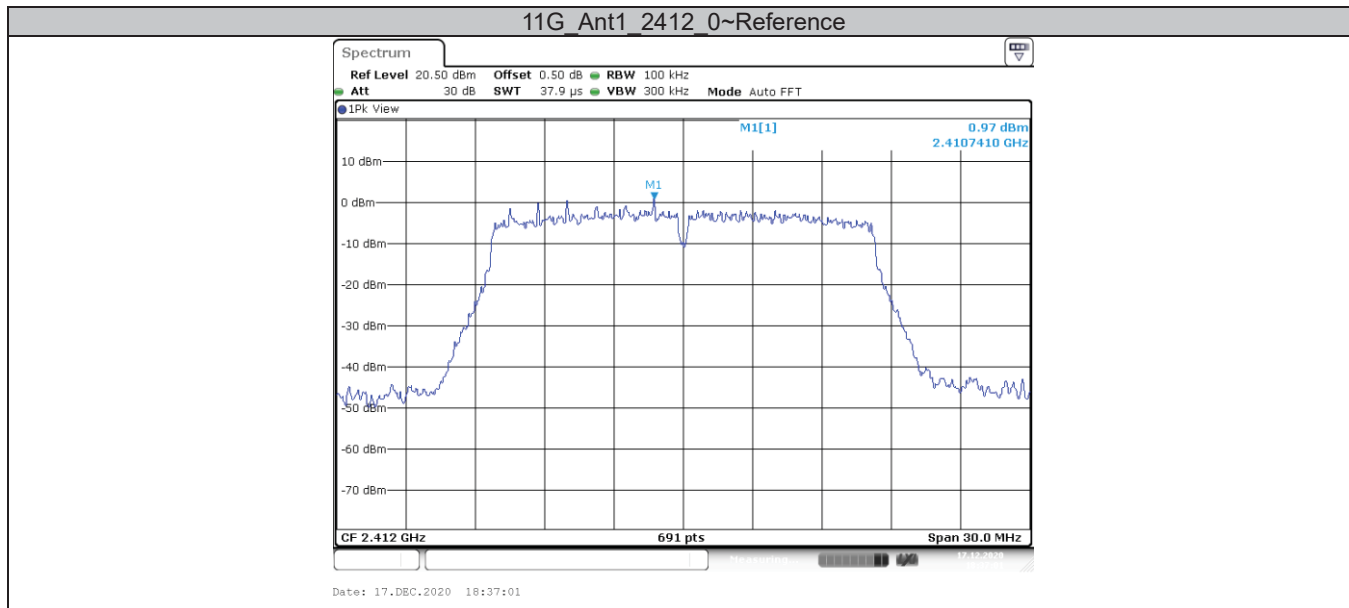

CTC Laboratories, Inc.

1-2/F., Building 2, Jiaquan Building, Guanlan High-Tech Park, Shenzhen, Guangdong, China
Tel.: (86)755-27521059 Fax: (86)755-27521011 Http://www.sz-ctc.org.cn



For anti-fake verification, please visit the official website of Certification and Accreditation Administration of the People's Republic of China: yz.cnca.cn

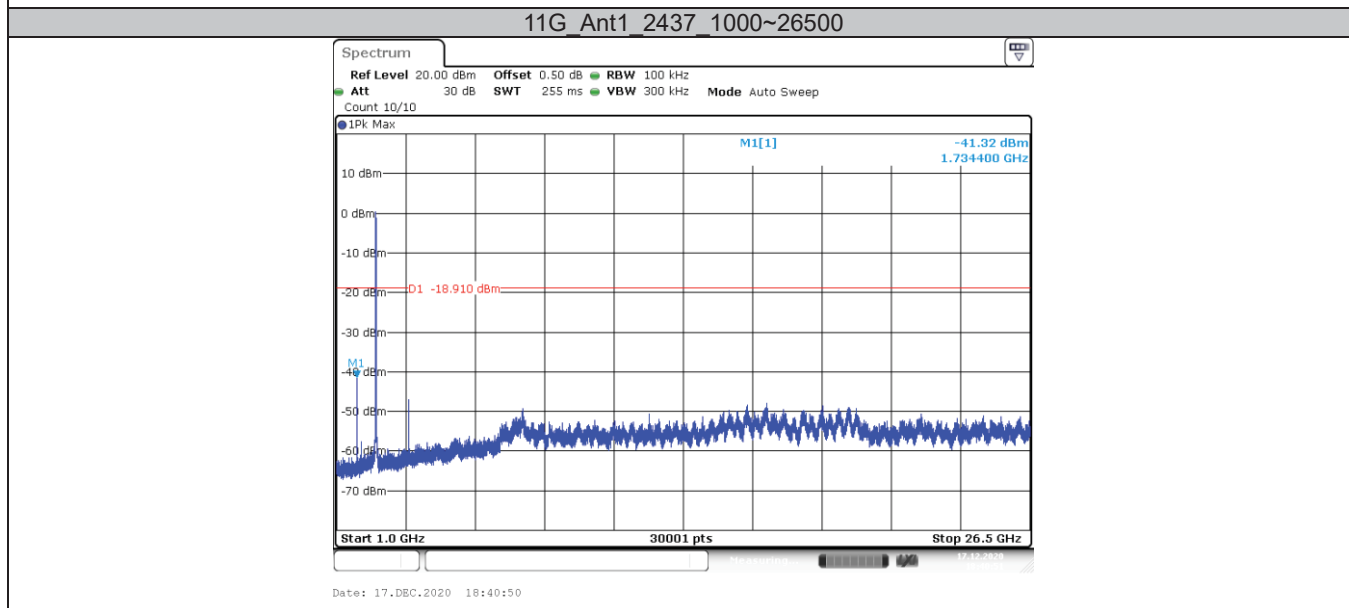
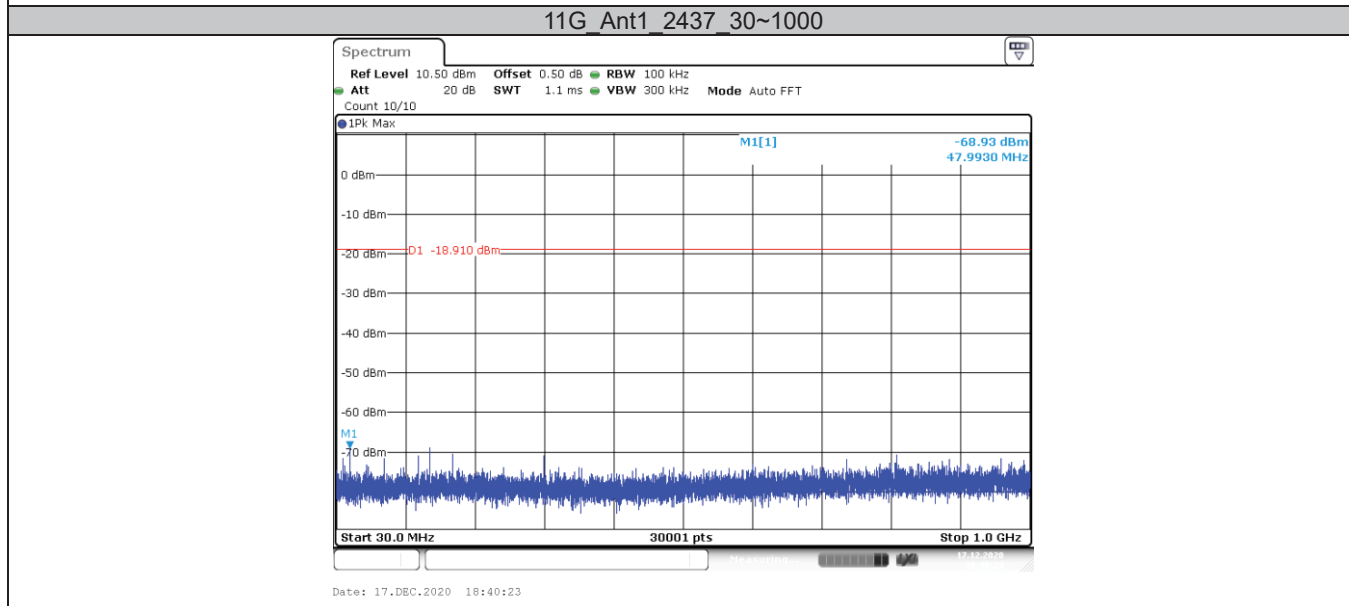
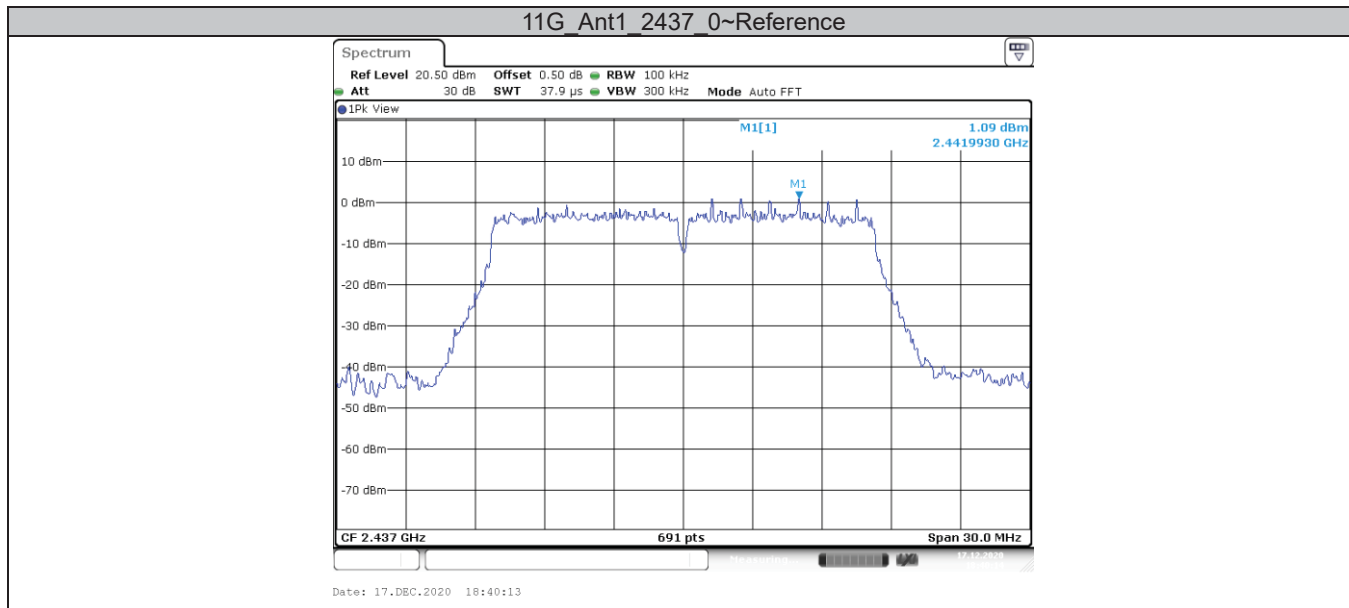

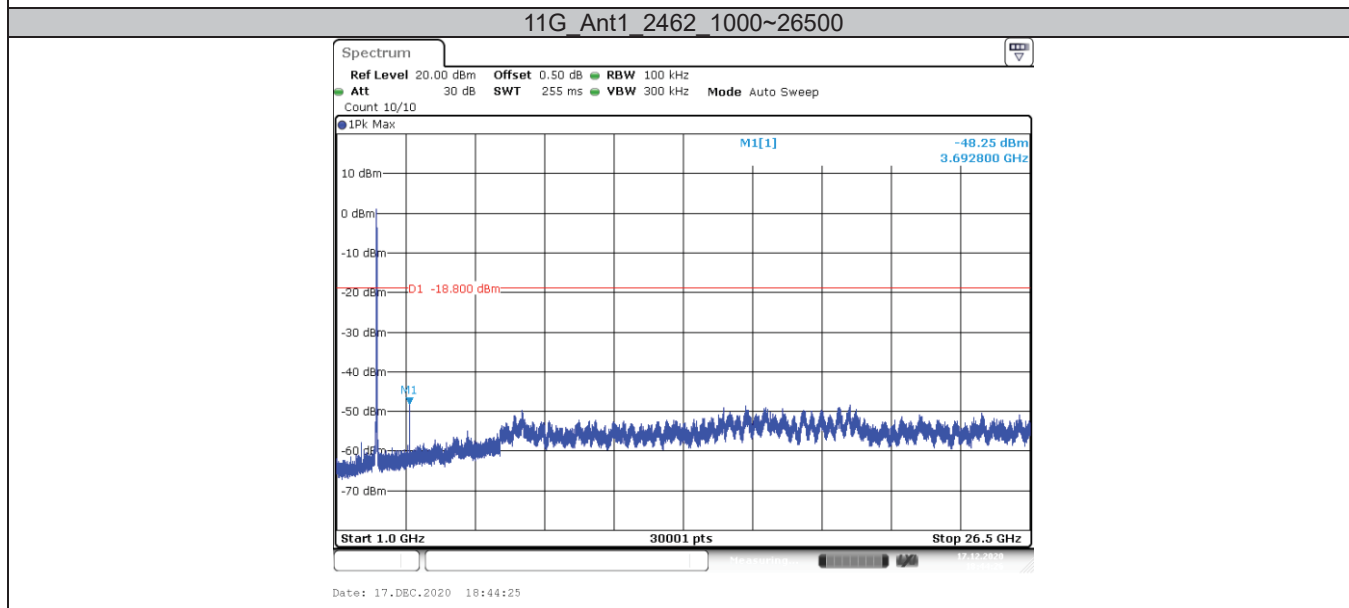
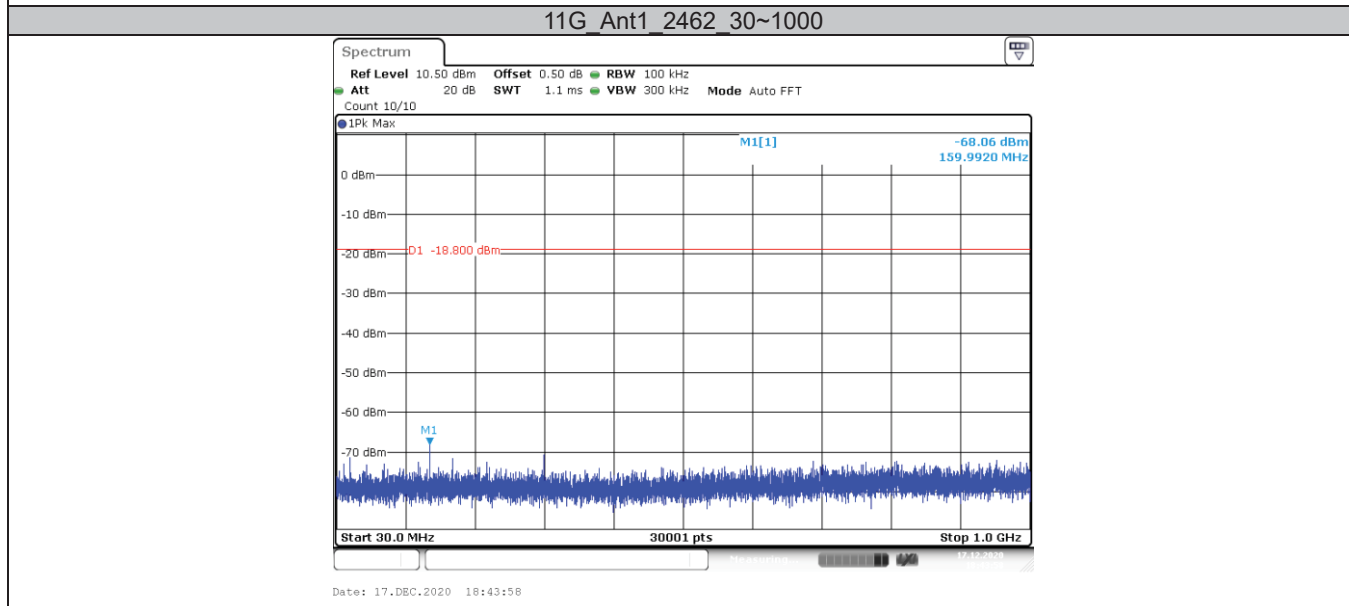
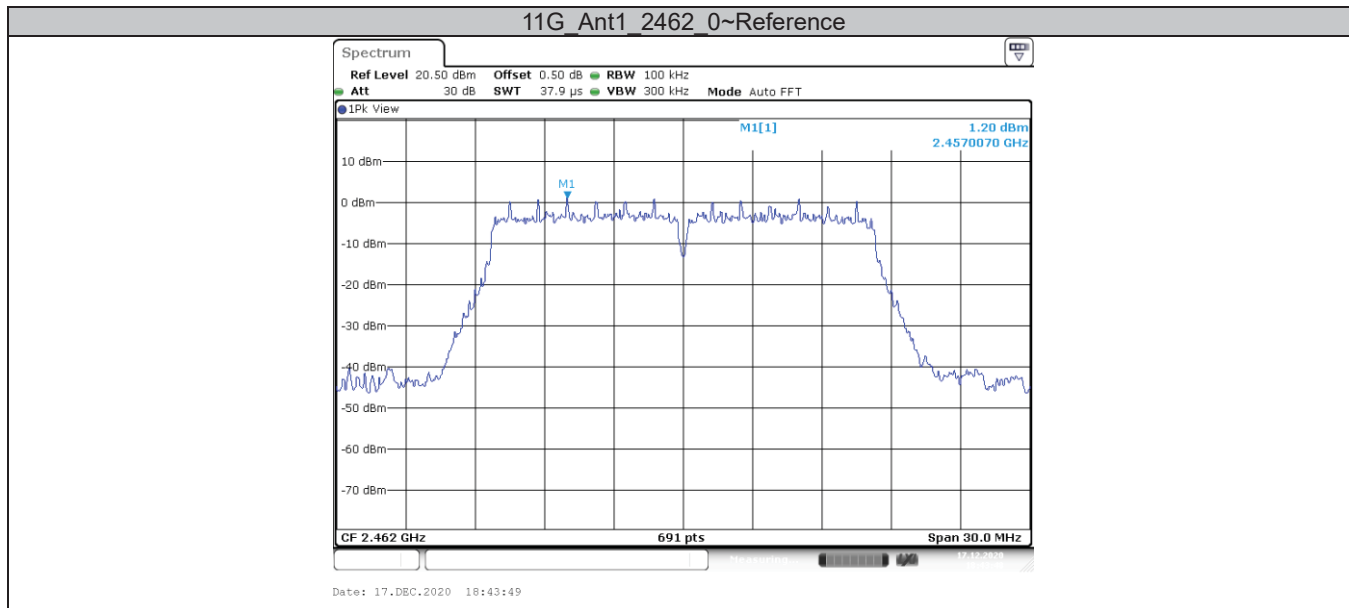

CTC Laboratories, Inc.

1-2/F., Building 2, Jiaquan Building, Guanlan High-Tech Park, Shenzhen, Guangdong, China
Tel.: (86)755-27521059 Fax: (86)755-27521011 Http://www.sz-ctc.org.cn



For anti-fake verification, please visit the official website of Certification and Accreditation Administration of the People's Republic of China : yz.cnca.cn

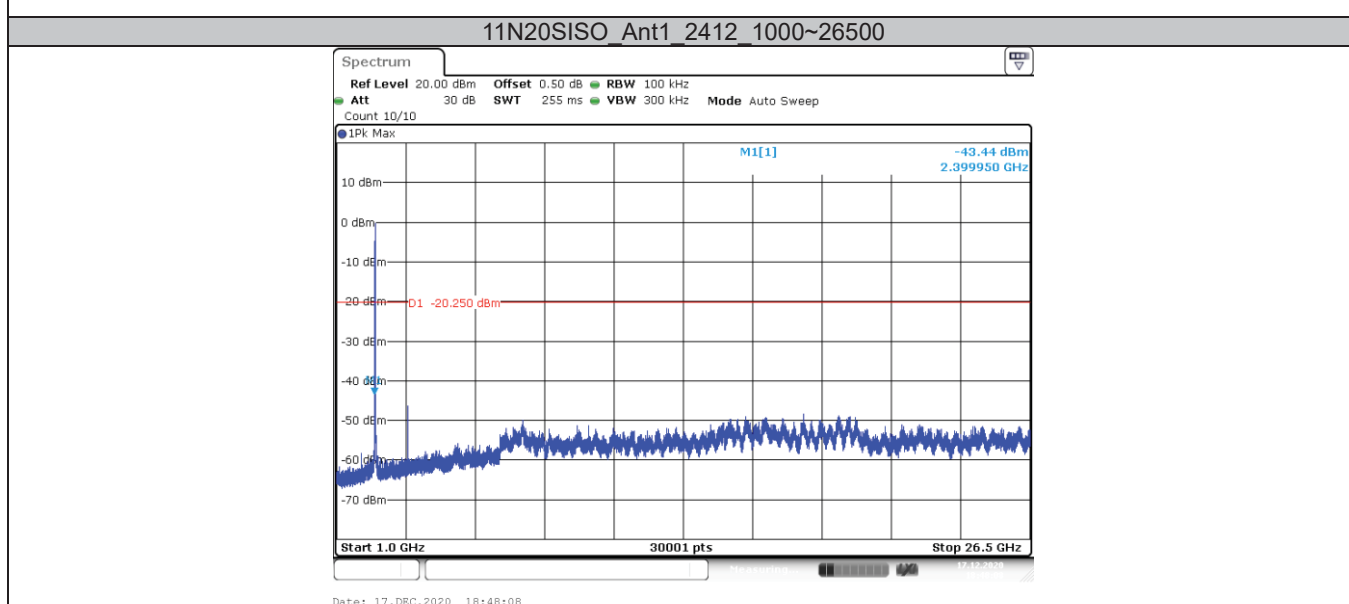
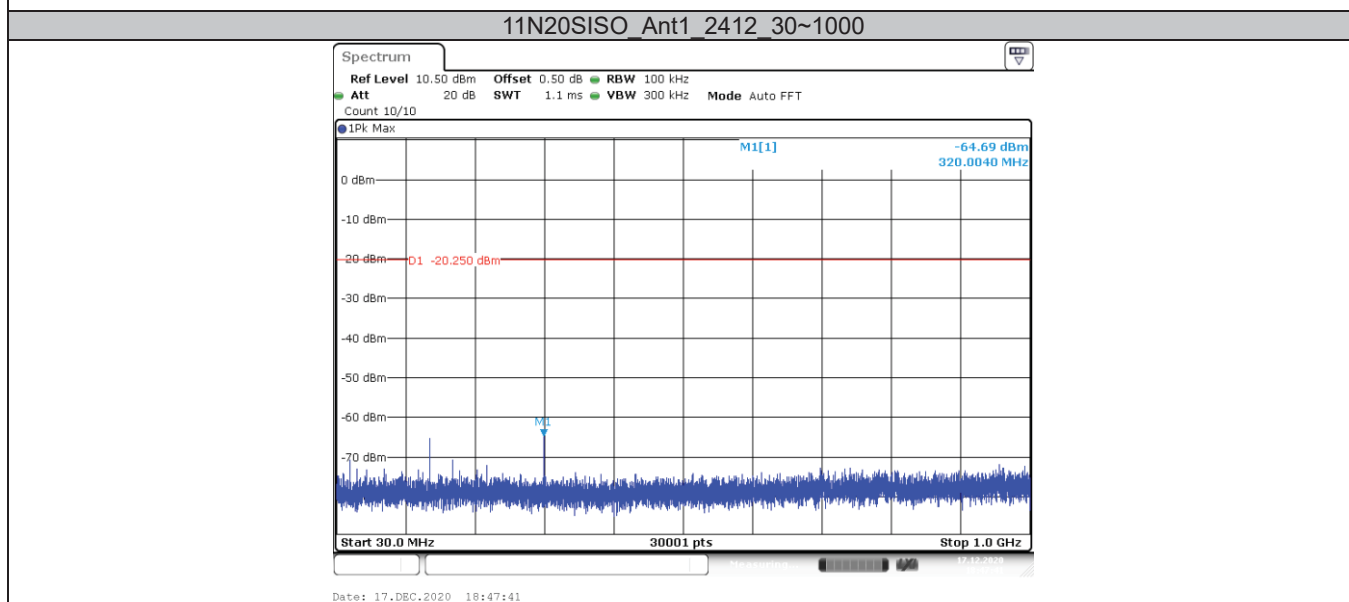
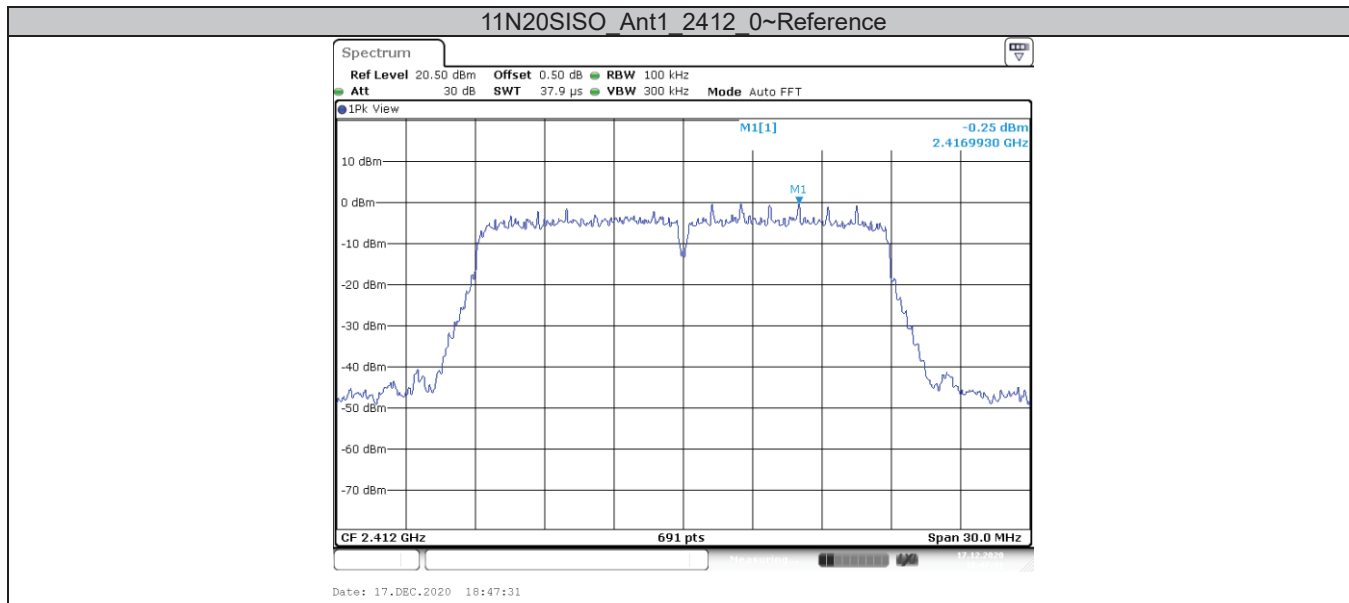

CTC Laboratories, Inc.

1-2/F., Building 2, Jiaquan Building, Guanlan High-Tech Park, Shenzhen, Guangdong, China
 Tel.: (86)755-27521059 Fax: (86)755-27521011 Http://www.sz-ctc.org.cn



For anti-fake verification, please visit the official website of Certification and Accreditation Administration of the People's Republic of China : yz.cnca.cn

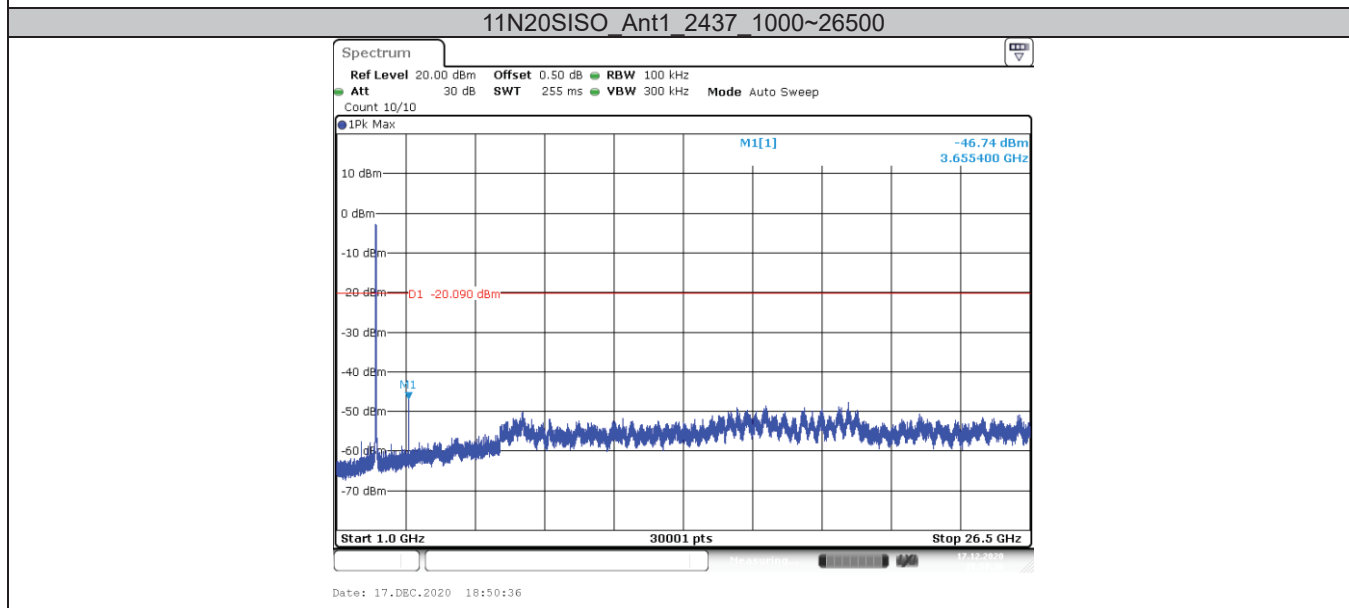
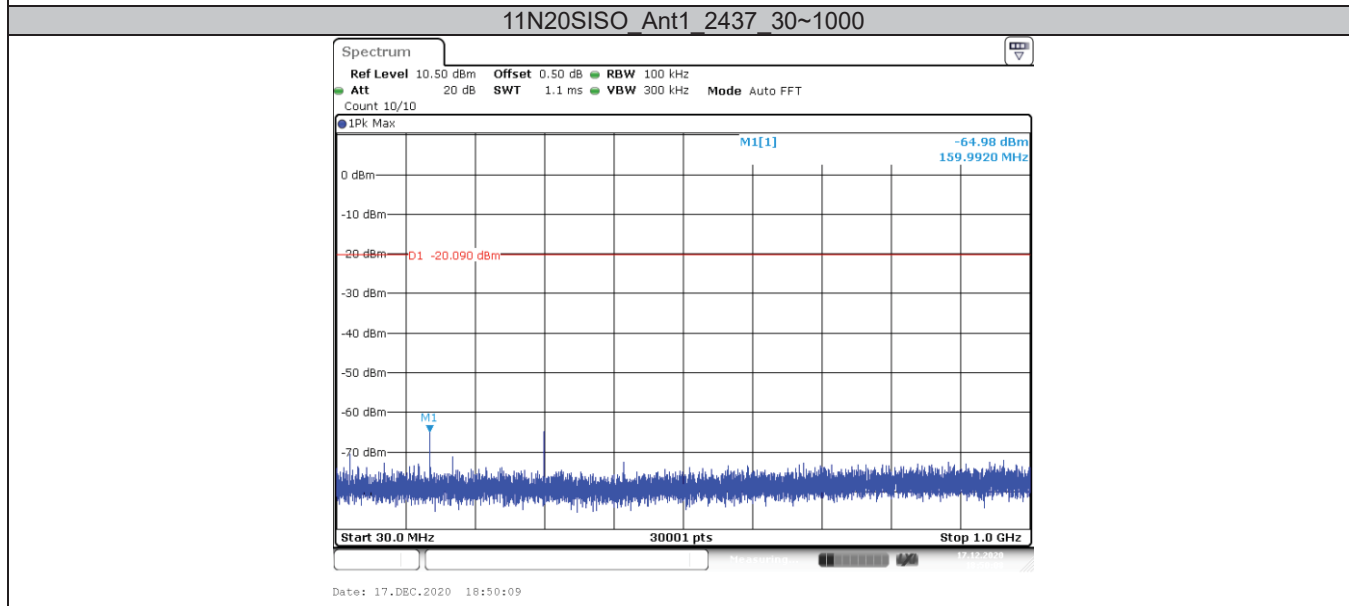
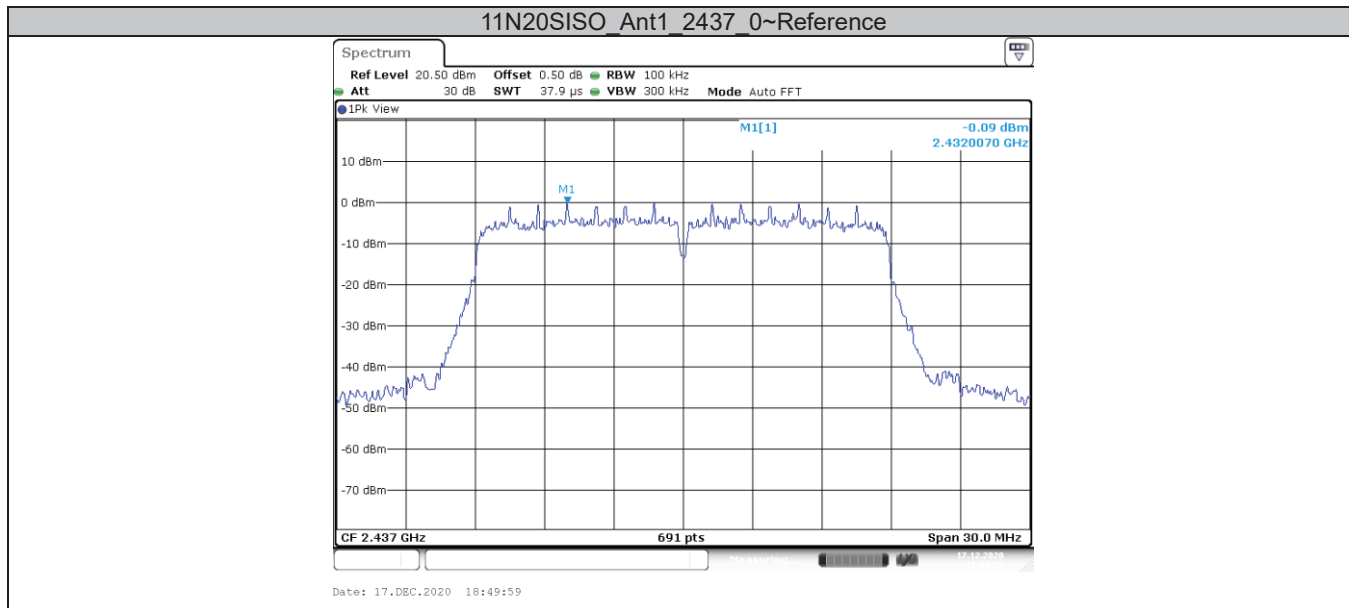

CTC Laboratories, Inc.

1-2/F., Building 2, Jiaquan Building, Guanlan High-Tech Park, Shenzhen, Guangdong, China
Tel.: (86)755-27521059 Fax: (86)755-27521011 Http://www.sz-ctc.org.cn



For anti-fake verification, please visit the official website of Certification and Accreditation Administration of the People's Republic of China : yz.cnca.cn

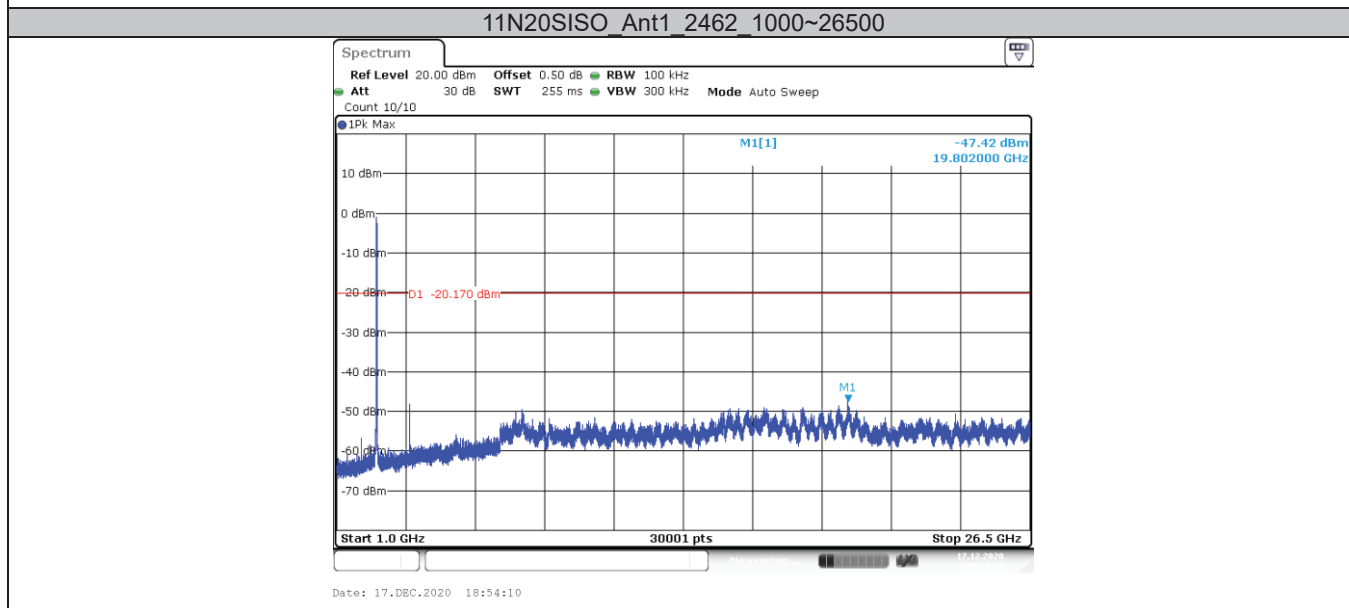
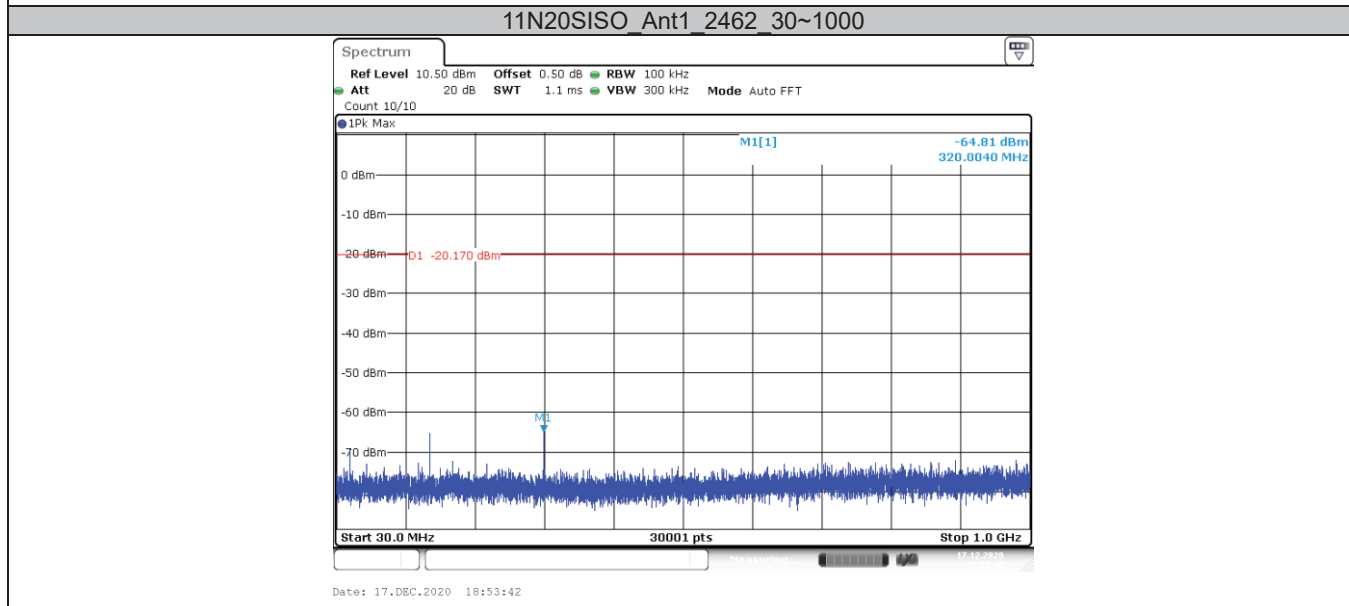
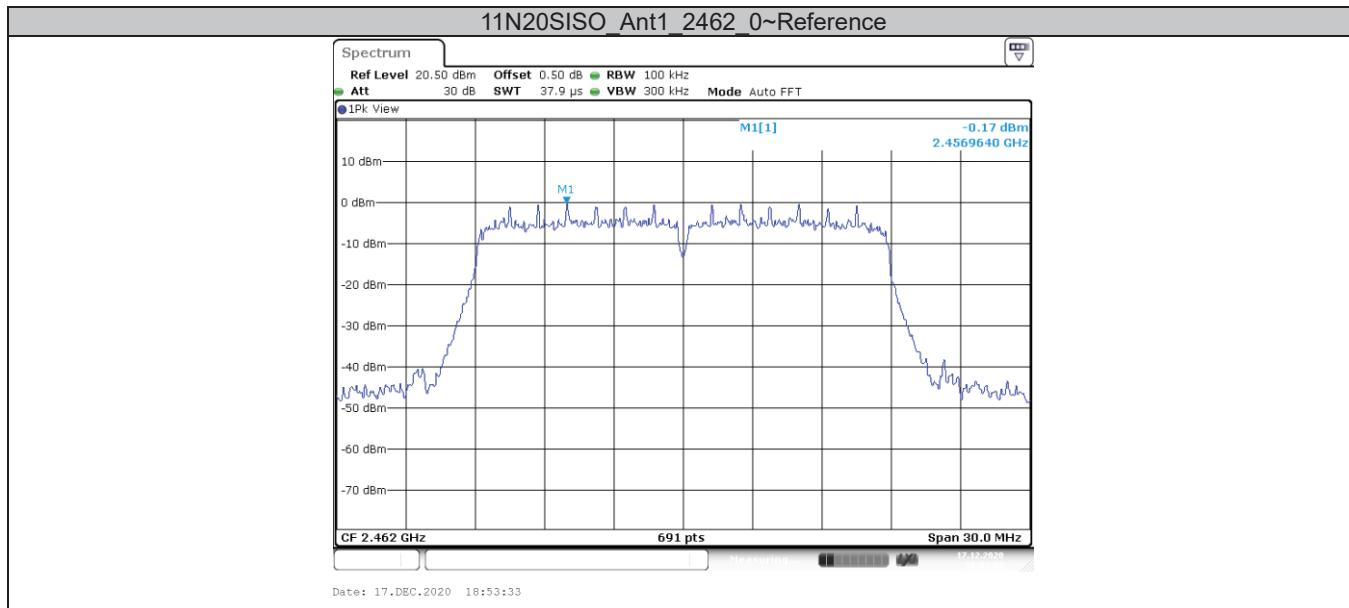

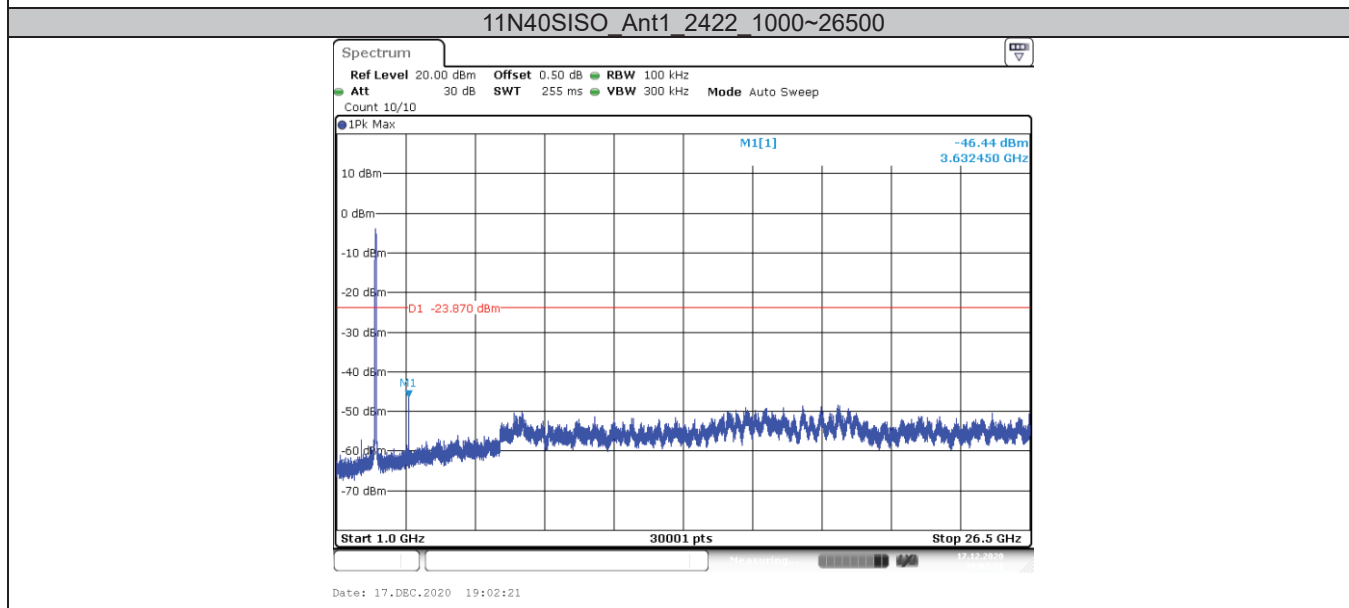
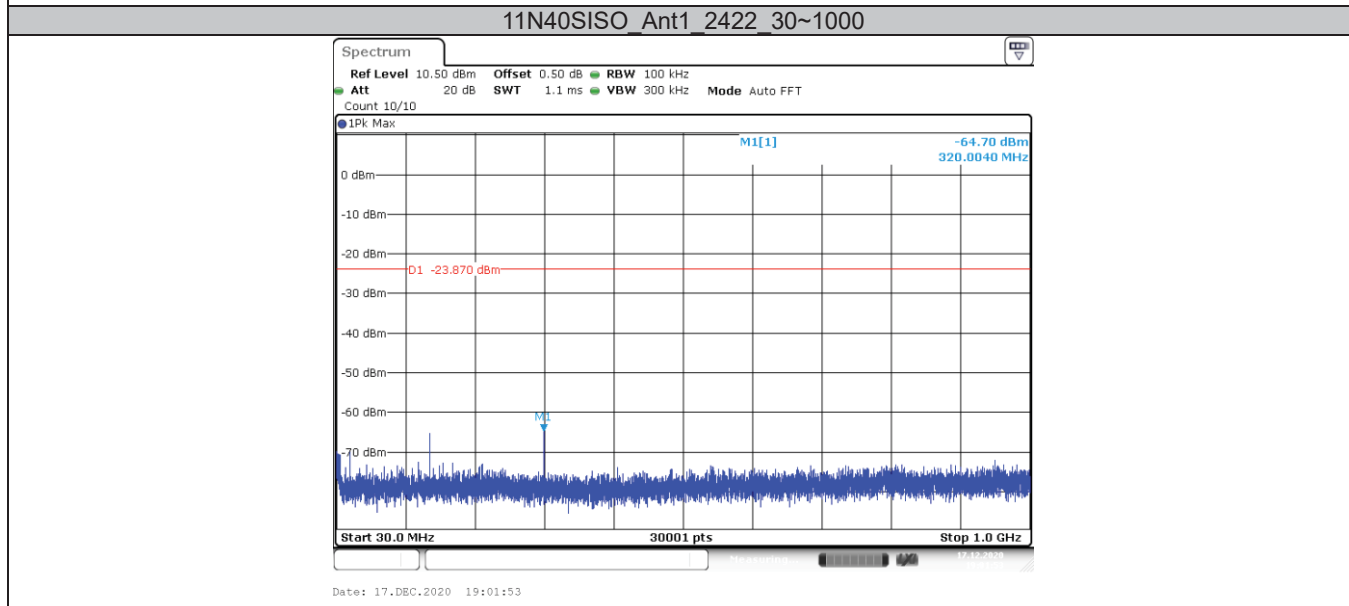
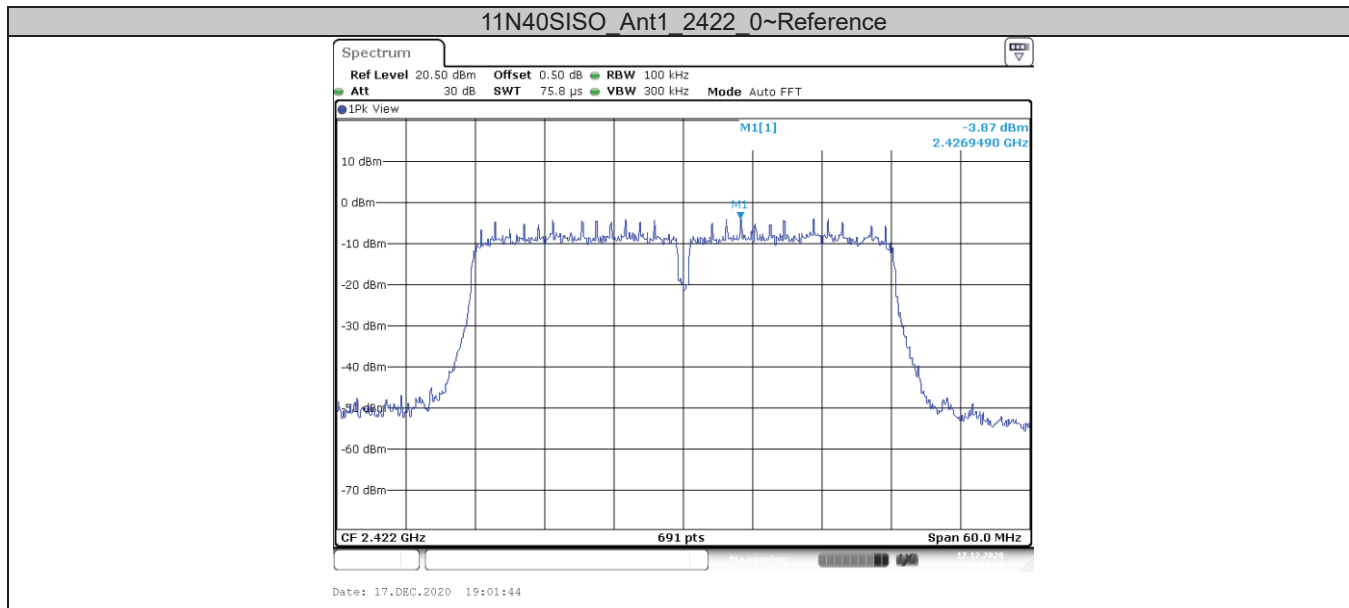

CTC Laboratories, Inc.

1-2/F., Building 2, Jiaquan Building, Guanlan High-Tech Park, Shenzhen, Guangdong, China
Tel.: (86)755-27521059 Fax: (86)755-27521011 Http://www.sz-ctc.org.cn



For anti-fake verification, please visit the official website of Certification and Accreditation Administration of the People's Republic of China : yz.cnca.cn

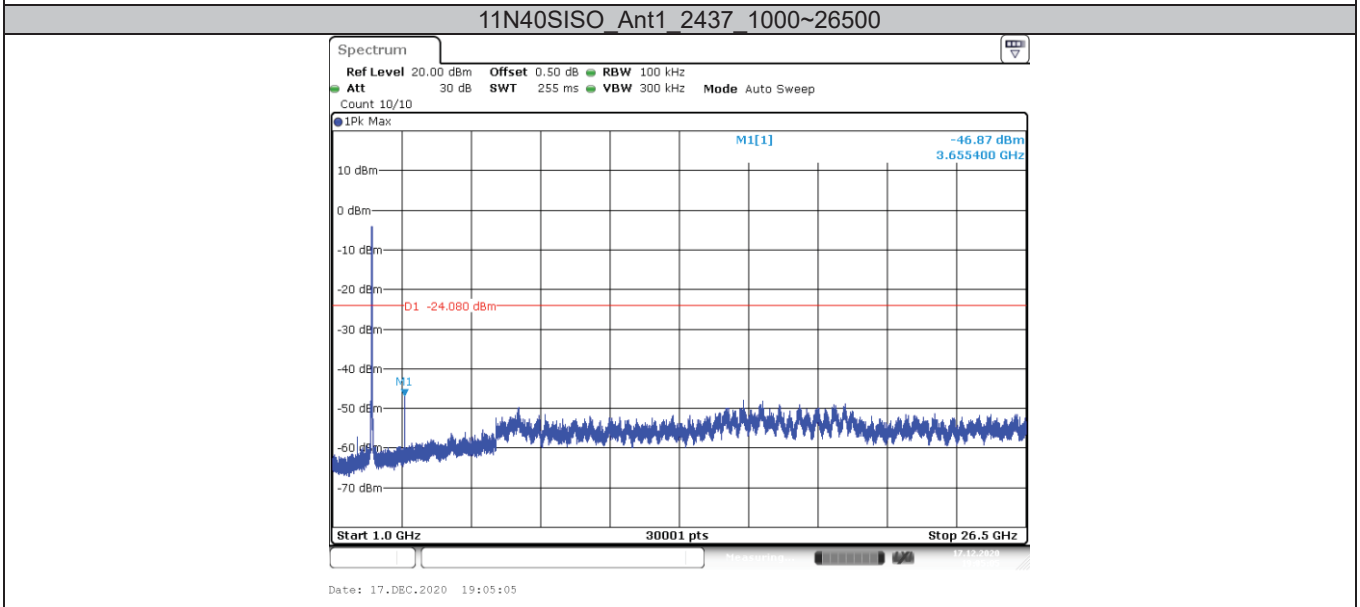
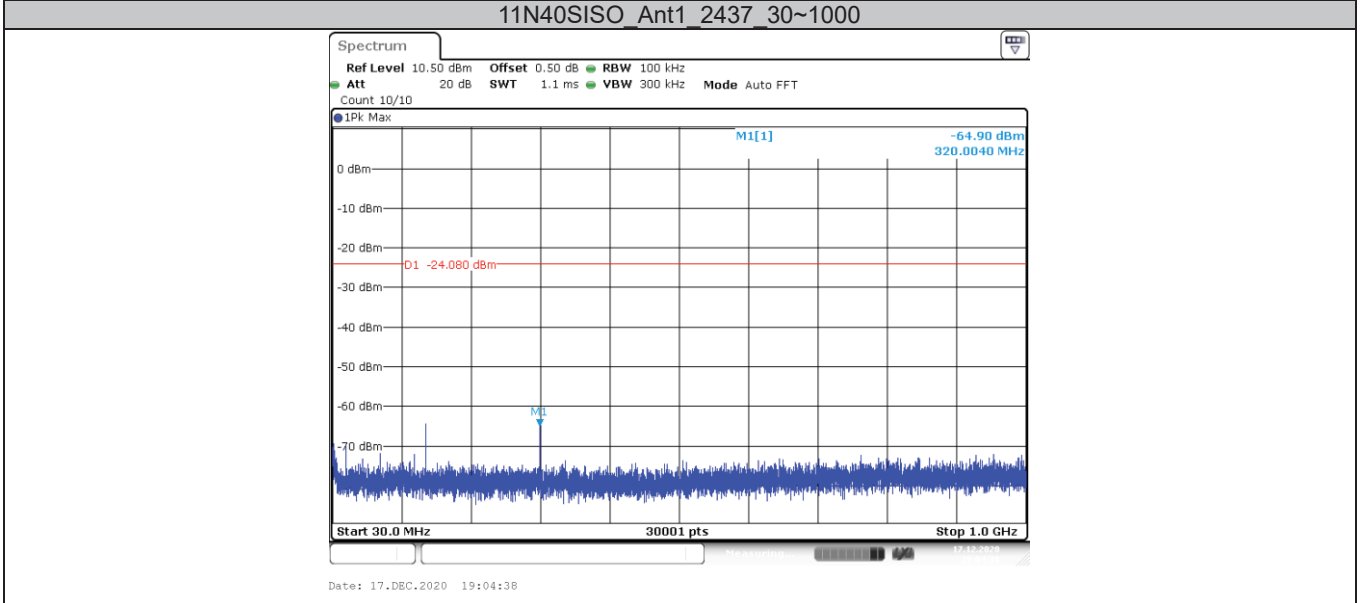
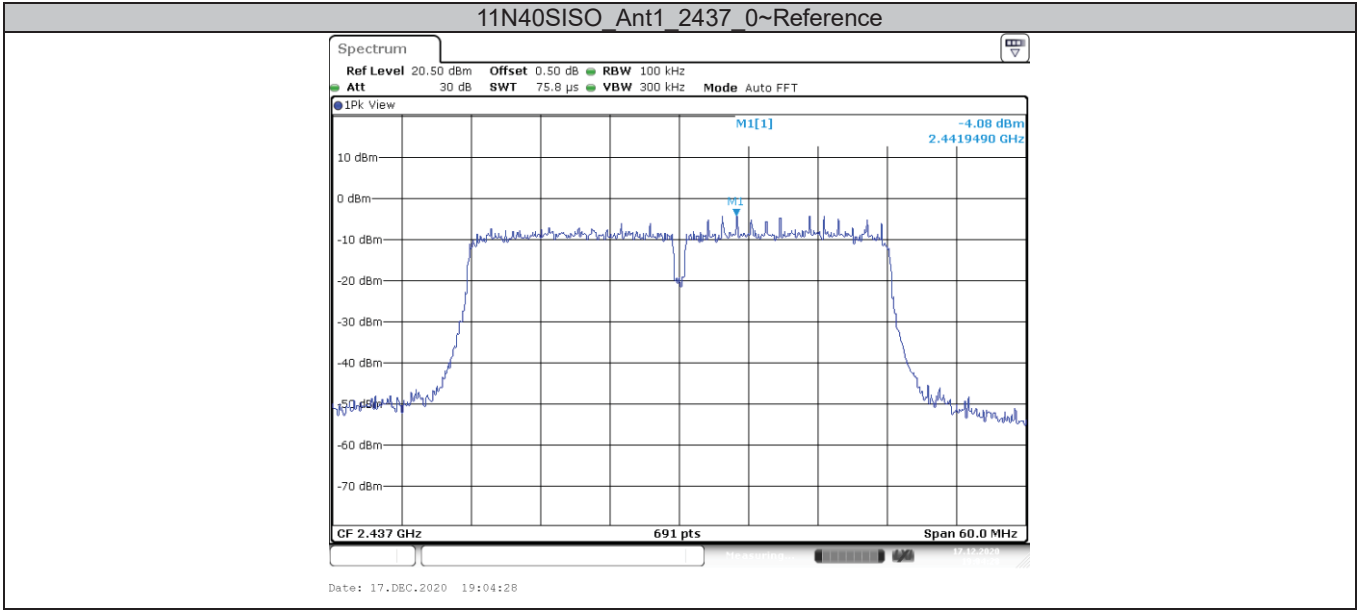

CTC Laboratories, Inc.

1-2/F., Building 2, Jiaquan Building, Guanlan High-Tech Park, Shenzhen, Guangdong, China
Tel.: (86)755-27521059 Fax: (86)755-27521011 Http://www.sz-ctc.org.cn



For anti-fake verification, please visit the official website of Certification and Accreditation Administration of the People's Republic of China : yz.cnca.cn

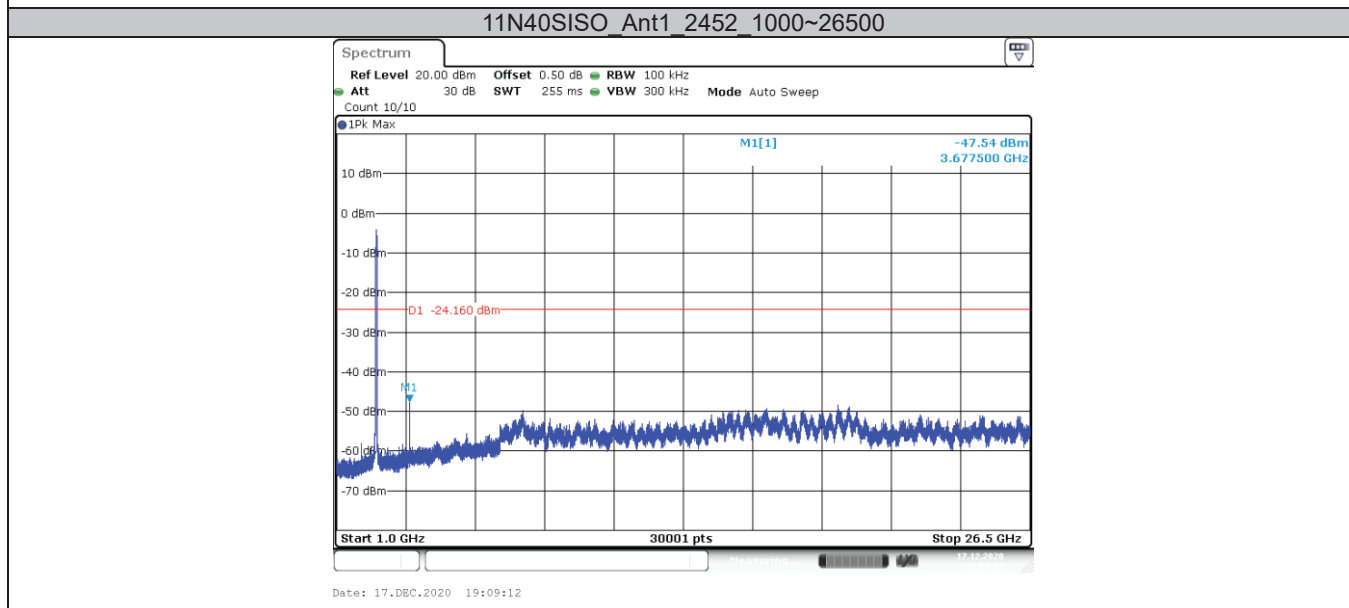
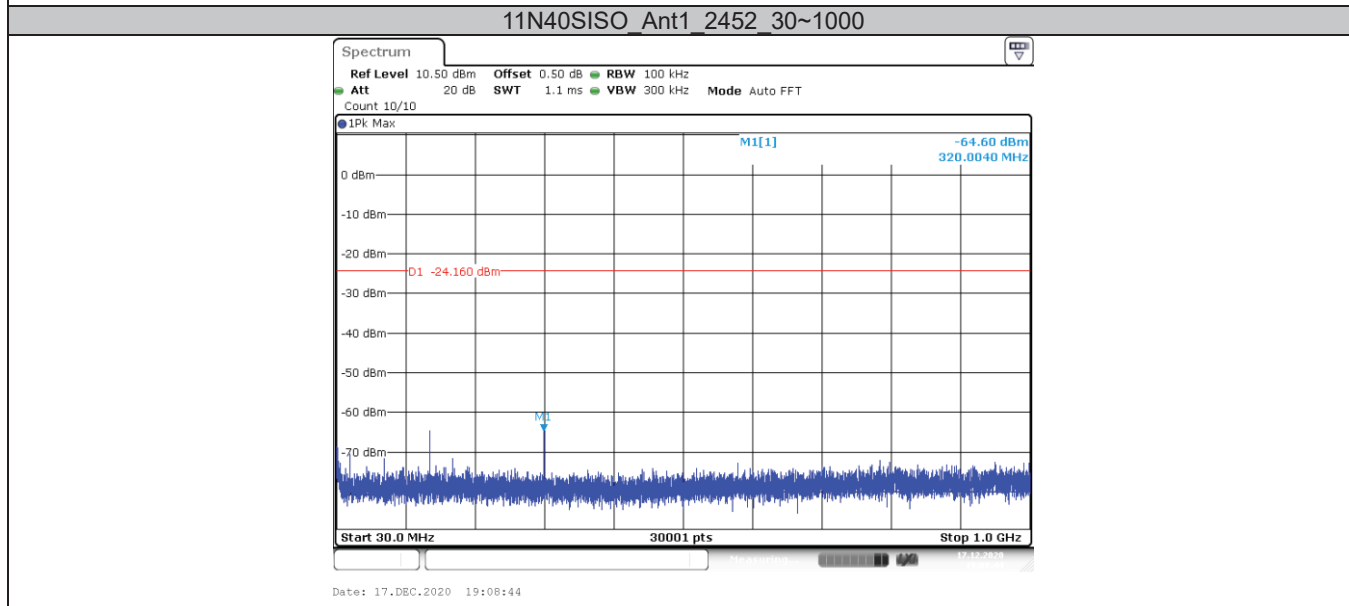
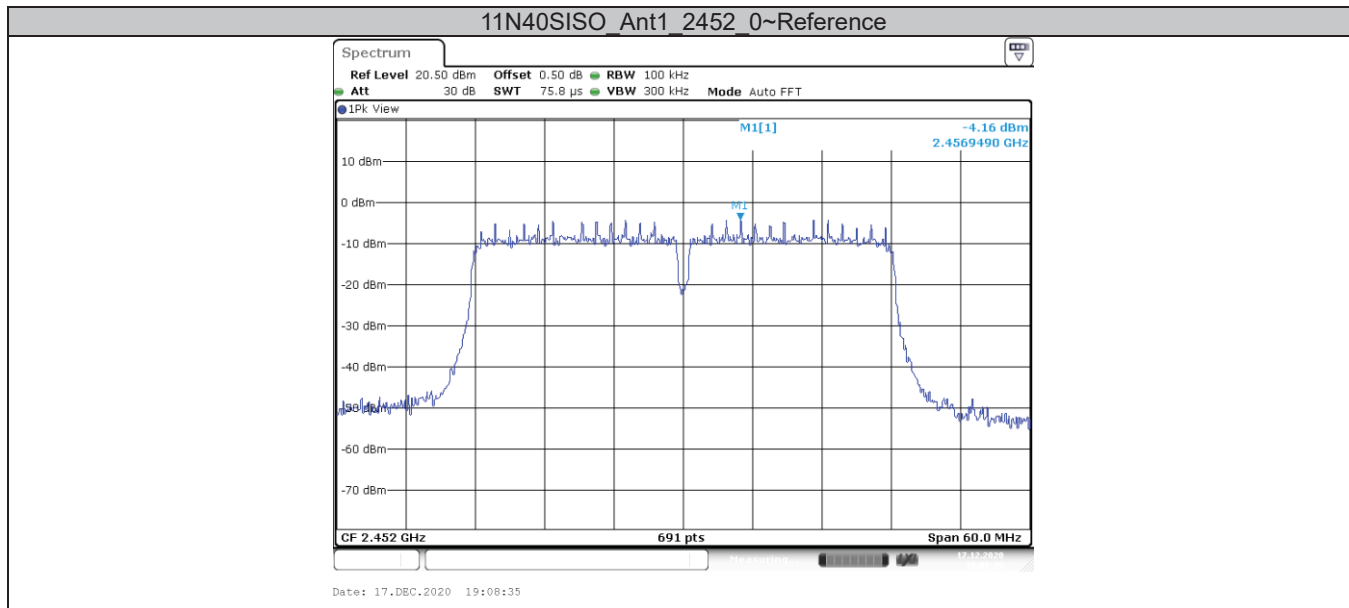

CTC Laboratories, Inc.

1-2/F., Building 2, Jiaquan Building, Guanlan High-Tech Park, Shenzhen, Guangdong, China
Tel.: (86)755-27521059 Fax: (86)755-27521011 Http://www.sz-ctc.org.cn



For anti-fake verification, please visit the official website of Certification and Accreditation Administration of the People's Republic of China : yz.cnca.cn

3.3. Band Edge Emissions

Limit

FCC CFR Title 47 Part 15 Subpart C Section 15.247 (d)

| Restricted Frequency Band (MHz) | (dBuV/m)(at 3m) | |
|---------------------------------|-----------------|---------|
| | Peak | Average |
| 2310 ~2390 | 74 | 54 |
| 2483.5 ~2500 | 74 | 54 |

Conducted band edge limit: The highest point of the operating frequency waveform down 20dB

Test Configuration

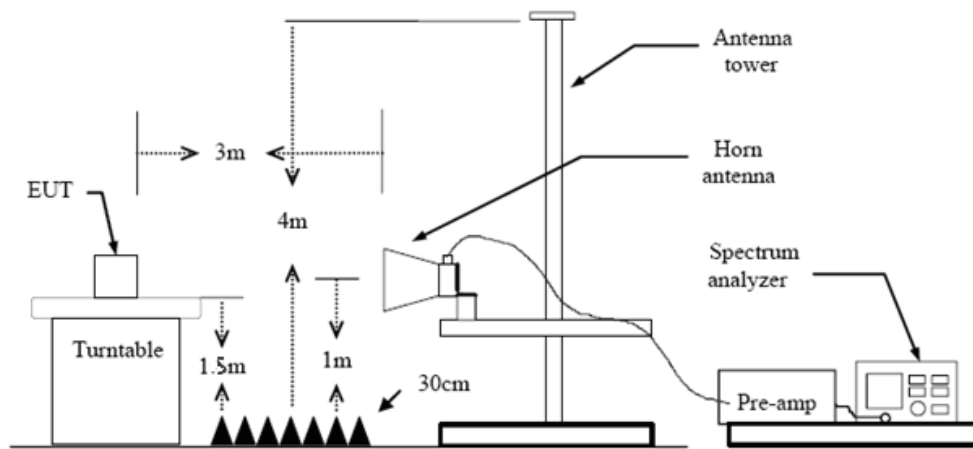

Test Procedure

1. The EUT was setup and tested according to ANSI C63.10:2013 requirements.
2. The EUT is placed on a turn table which is 1.5 meter above ground. The turn table is rotated 360 degrees to determine the position of the maximum emission level.
3. The EUT was positioned such that the distance from antenna to the EUT was 3 meters.
4. The antenna is scanned from 1 meter to 4 meters to find out the maximum emission level. This is repeated for both horizontal and vertical polarization of the antenna. In order to find the maximum emission, all of the interface cables were manipulated according to ANSI C63.10:2013 on radiated measurement.
5. The receiver set as follow:
 RBW=1MHz, VBW=3MHz Peak detector for Peak value.
 RBW=1MHz, VBW see note 1 with Peak Detector for Average Value.

Note 1: For measurements above 1 GHz the resolution bandwidth is set to 1 MHz, then the video bandwidth is set to 3 MHz for peak measurements and 1 MHz resolution bandwidth with 1/T video bandwidth with peak detector for average measurements. For the Duty Cycle please refer to clause 3.7 Duty Cycle.

Test Mode

Please refer to the clause 2.3.

Test Results



| | |
|------------|----------------|
| Ant. Pol. | Horizontal |
| Test Mode: | B Mode 2412MHz |

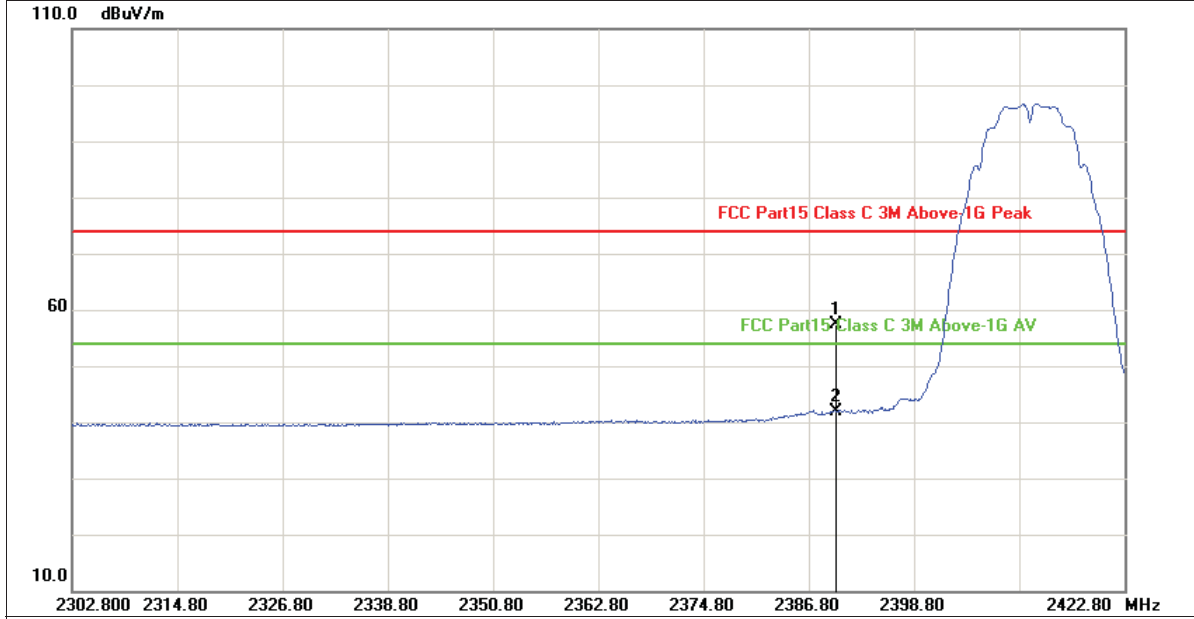

| No. | Frequency (MHz) | Factor (dB/m) | Reading (dBuV) | Level (dBuV/m) | Limit (dBuV/m) | Margin (dB) | Detector |
|-----|-----------------|---------------|----------------|----------------|----------------|-------------|----------|
| 1 | 2390.000 | 31.10 | 26.29 | 57.39 | 74.00 | -16.61 | peak |
| 2 | 2390.000 | 31.10 | 10.85 | 41.95 | 54.00 | -12.05 | AVG |

Remarks:

1. Factor (dB/m) = Antenna Factor (dB/m)+Cable Factor (dB)-Pre-amplifier Factor
2. Margin value = Level -Limit value



| | |
|------------|----------------|
| Ant. Pol. | Vertical |
| Test Mode: | B Mode 2412MHz |

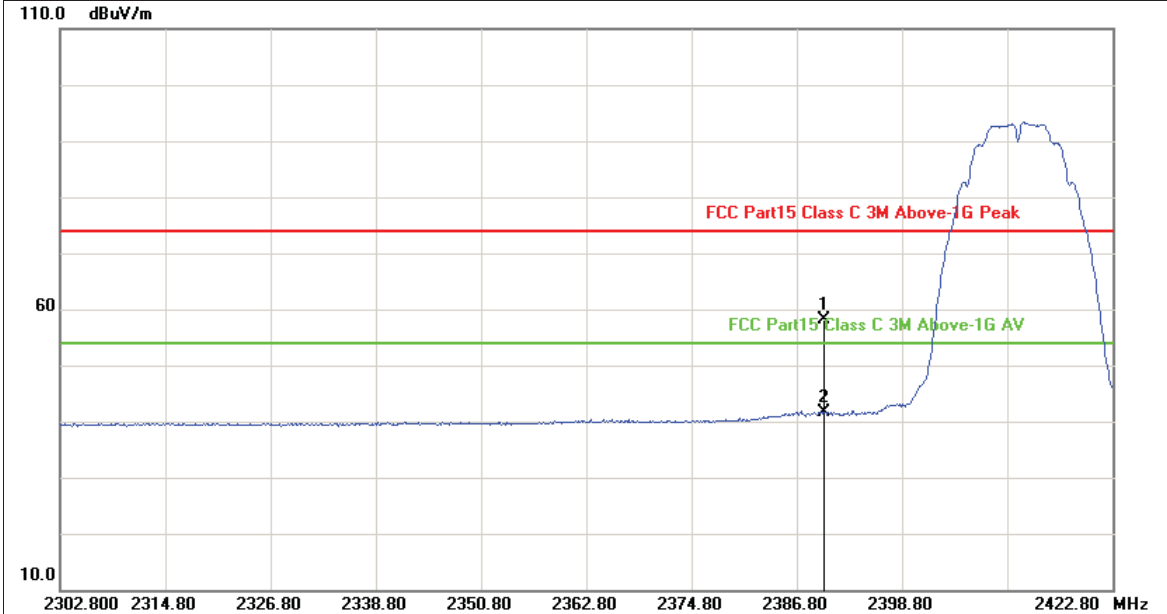

| No. | Frequency (MHz) | Factor (dB/m) | Reading (dBuV) | Level (dBuV/m) | Limit (dBuV/m) | Margin (dB) | Detector |
|-----|-----------------|---------------|----------------|----------------|----------------|-------------|----------|
| 1 | 2390.000 | 31.10 | 27.10 | 58.20 | 74.00 | -15.80 | peak |
| 2 | 2390.000 | 31.10 | 10.49 | 41.59 | 54.00 | -12.41 | AVG |

Remarks:

1. Factor (dB/m) = Antenna Factor (dB/m) + Cable Factor (dB) - Pre-amplifier Factor
2. Margin value = Level - Limit value



| | |
|-------------------|-----------------|
| Ant. Pol. | Horizontal |
| Test Mode: | B Mode 2462 MHz |

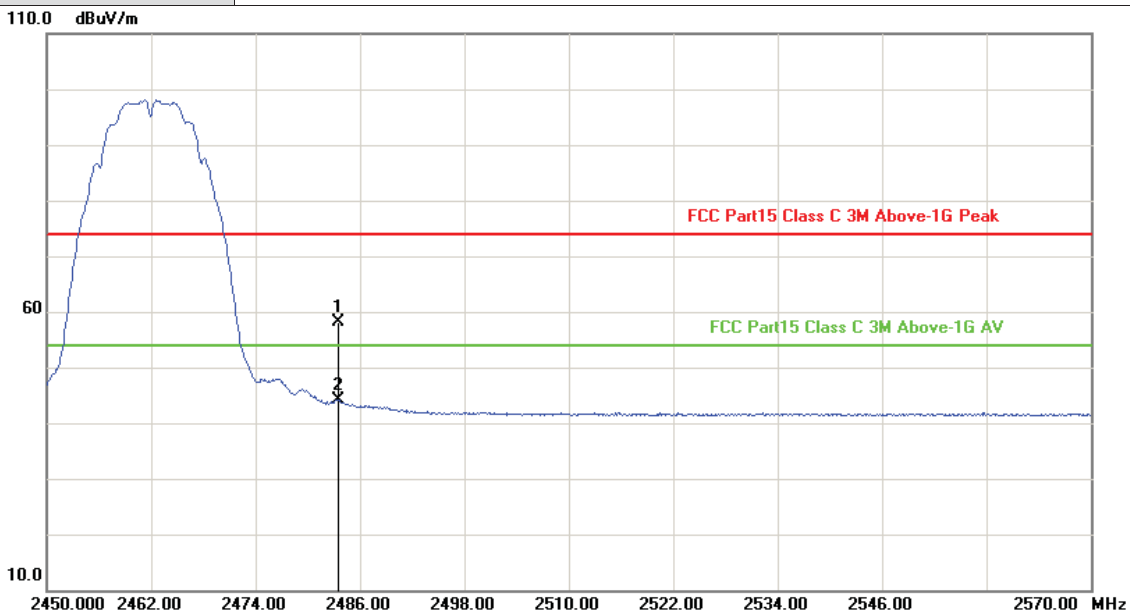

| No. | Frequency (MHz) | Factor (dB/m) | Reading (dBuV) | Level (dBuV/m) | Limit (dBuV/m) | Margin (dB) | Detector |
|-----|-----------------|---------------|----------------|----------------|----------------|-------------|----------|
| 1 | 2483.500 | 31.50 | 26.74 | 58.24 | 74.00 | -15.76 | peak |
| 2 | 2483.500 | 31.50 | 12.53 | 44.03 | 54.00 | -9.97 | AVG |

Remarks:

1. Factor (dB/m) = Antenna Factor (dB/m)+Cable Factor (dB)-Pre-amplifier Factor
2. Margin value = Level -Limit value



| | |
|------------|-----------------|
| Ant. Pol. | Vertical |
| Test Mode: | B Mode 2462 MHz |

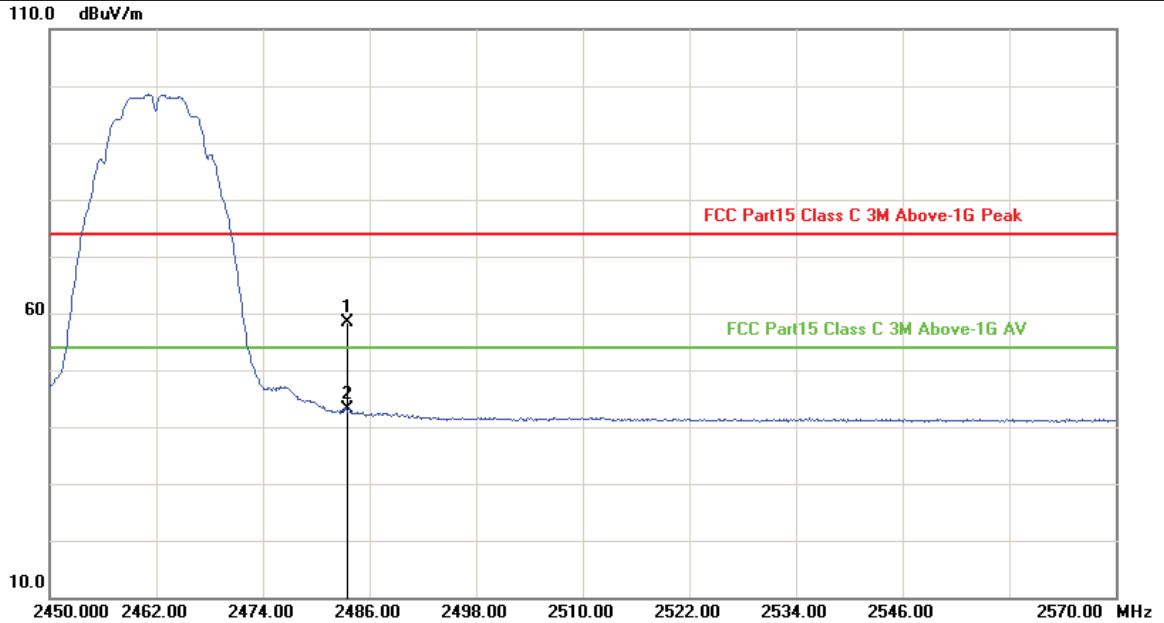

| No. | Frequency (MHz) | Factor (dB/m) | Reading (dBuV) | Level (dBuV/m) | Limit (dBuV/m) | Margin (dB) | Detector |
|-----|-----------------|---------------|----------------|----------------|----------------|-------------|----------|
| 1 | 2483.500 | 31.50 | 26.89 | 58.39 | 74.00 | -15.61 | peak |
| 2 | 2483.500 | 31.50 | 11.54 | 43.04 | 54.00 | -10.96 | AVG |

Remarks:

- Factor (dB/m) = Antenna Factor (dB/m)+Cable Factor (dB)-Pre-amplifier Factor
- Margin value = Level -Limit value



| | |
|------------|----------------|
| Ant. Pol. | Horizontal |
| Test Mode: | G Mode 2412MHz |

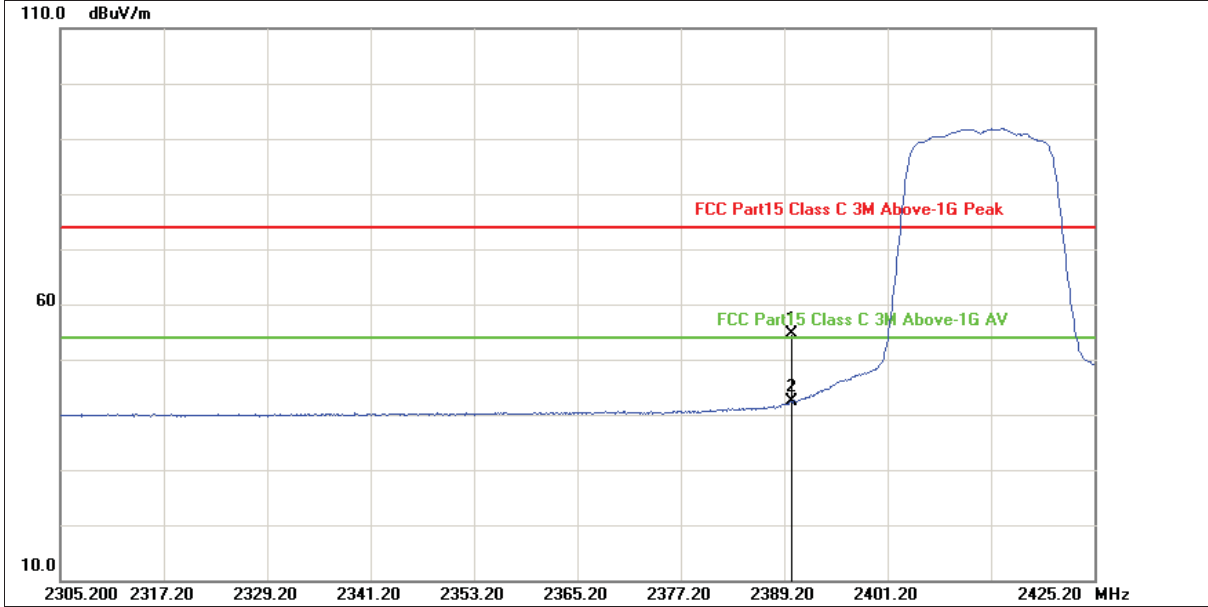

| No. | Frequency (MHz) | Factor (dB/m) | Reading (dBuV) | Level (dBuV/m) | Limit (dBuV/m) | Margin (dB) | Detector |
|-----|-----------------|---------------|----------------|----------------|----------------|-------------|----------|
| 1 | 2390.000 | 31.10 | 23.61 | 54.71 | 74.00 | -19.29 | peak |
| 2 | 2390.000 | 31.10 | 11.19 | 42.29 | 54.00 | -11.71 | AVG |

Remarks:
 1. Factor (dB/m) = Antenna Factor (dB/m)+Cable Factor (dB)-Pre-amplifier Factor
 2. Margin value = Level -Limit value



| | |
|-------------------|----------------|
| Ant. Pol. | Vertical |
| Test Mode: | G Mode 2412MHz |

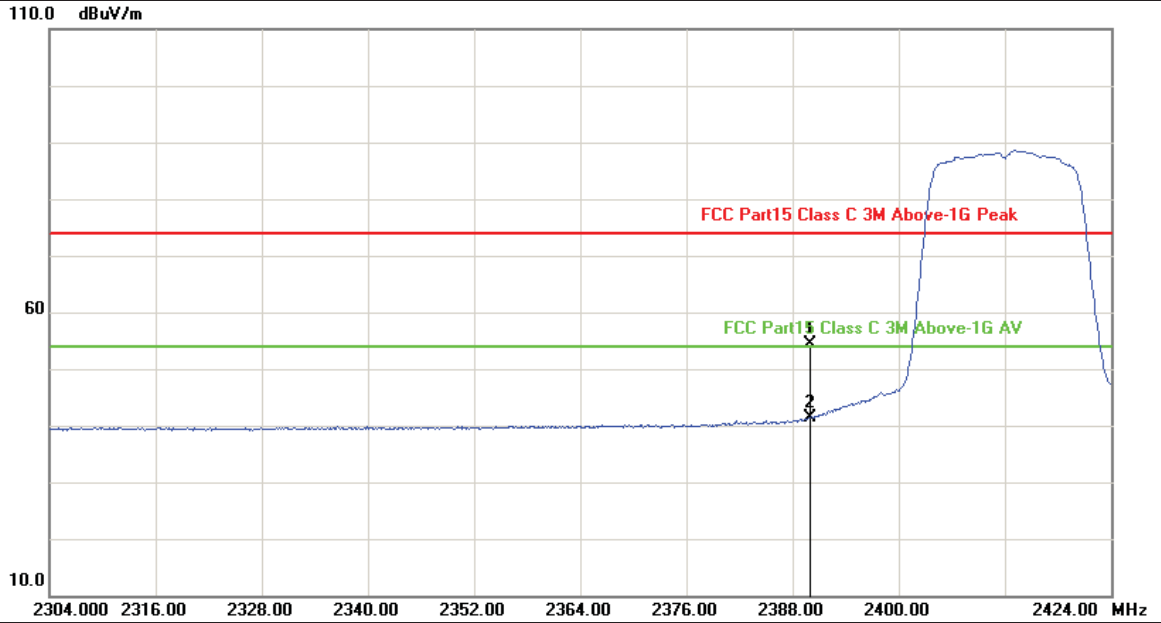

| No. | Frequency (MHz) | Factor (dB/m) | Reading (dBuV) | Level (dBuV/m) | Limit (dBuV/m) | Margin (dB) | Detector |
|-----|-----------------|---------------|----------------|----------------|----------------|-------------|----------|
| 1 | 2390.000 | 31.10 | 23.38 | 54.48 | 74.00 | -19.52 | peak |
| 2 | 2390.000 | 31.10 | 10.29 | 41.39 | 54.00 | -12.61 | AVG |

Remarks:

- 1. Factor (dB/m) = Antenna Factor (dB/m)+Cable Factor (dB)-Pre-amplifier Factor
- 2. Margin value = Level -Limit value



| | |
|-------------------|----------------|
| Ant. Pol. | Horizontal |
| Test Mode: | G Mode 2462MHz |

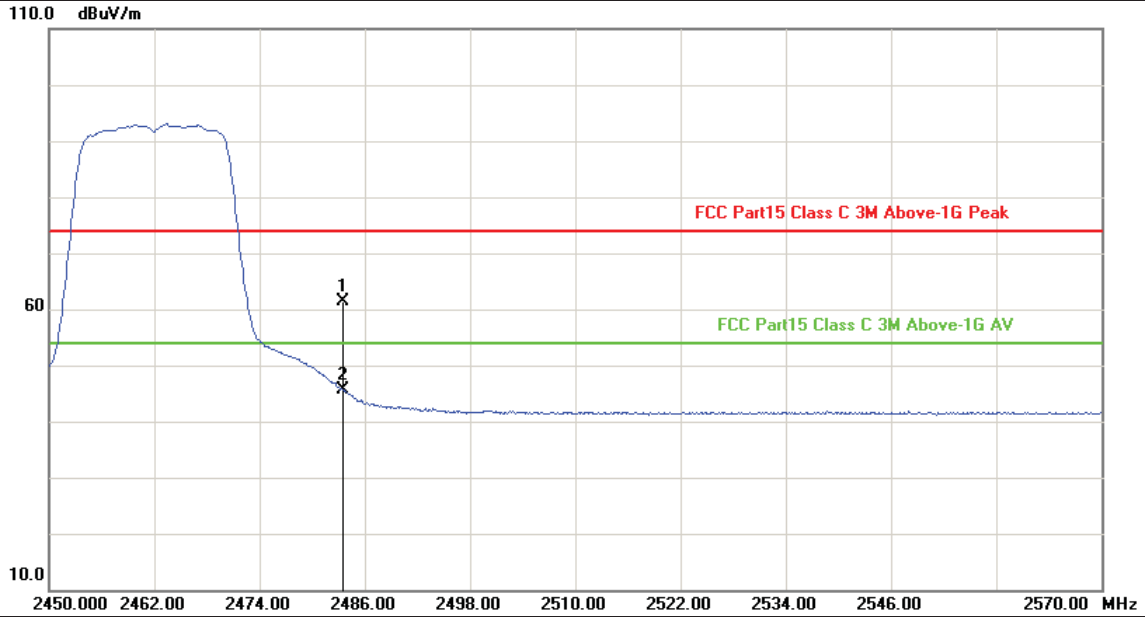

| No. | Frequency (MHz) | Factor (dB/m) | Reading (dBuV) | Level (dBuV/m) | Limit (dBuV/m) | Margin (dB) | Detector |
|-----|-----------------|---------------|----------------|----------------|----------------|-------------|----------|
| 1 | 2483.500 | 31.50 | 29.93 | 61.43 | 74.00 | -12.57 | peak |
| 2 | 2483.500 | 31.50 | 14.06 | 45.56 | 54.00 | -8.44 | AVG |

Remarks:

- 1. Factor (dB/m) = Antenna Factor (dB/m)+Cable Factor (dB)-Pre-amplifier Factor
- 2. Margin value = Level -Limit value



| | |
|------------|----------------|
| Ant. Pol. | Vertical |
| Test Mode: | G Mode 2462MHz |

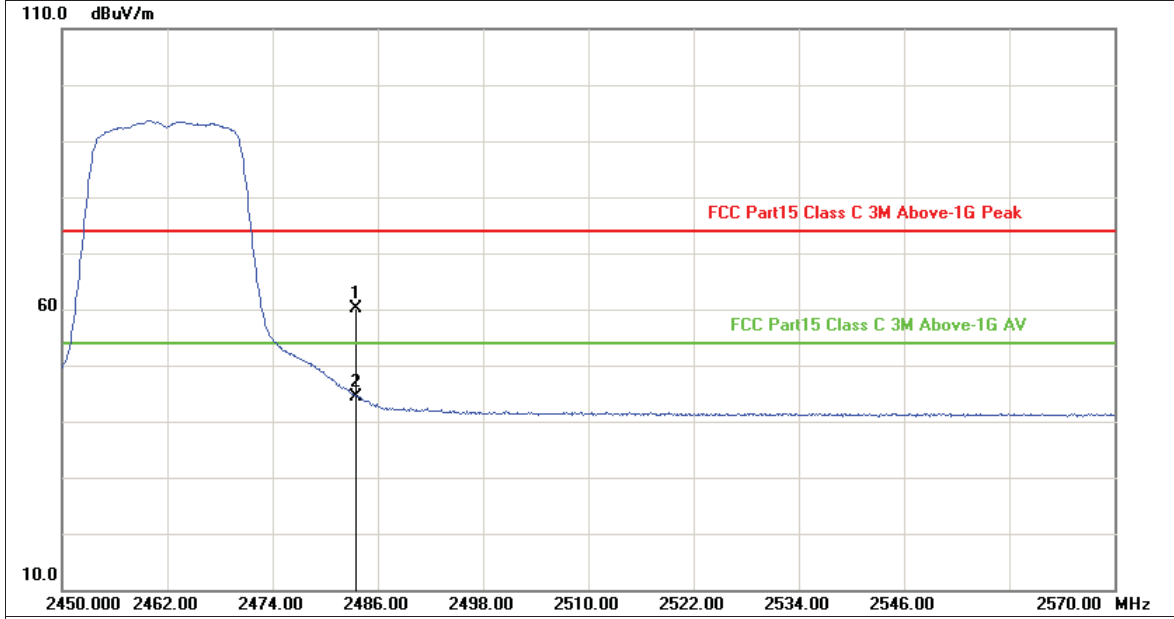

| No. | Frequency (MHz) | Factor (dB/m) | Reading (dBuV) | Level (dBuV/m) | Limit (dBuV/m) | Margin (dB) | Detector |
|-----|-----------------|---------------|----------------|----------------|----------------|-------------|----------|
| 1 | 2483.500 | 31.50 | 28.69 | 60.19 | 74.00 | -13.81 | peak |
| 2 | 2483.500 | 31.50 | 13.00 | 44.50 | 54.00 | -9.50 | AVG |

Remarks:

- Factor (dB/m) = Antenna Factor (dB/m)+Cable Factor (dB)-Pre-amplifier Factor
- Margin value = Level -Limit value



| | |
|-------------------|----------------------|
| Ant. Pol. | Horizontal |
| Test Mode: | N(HT20) Mode 2412MHz |

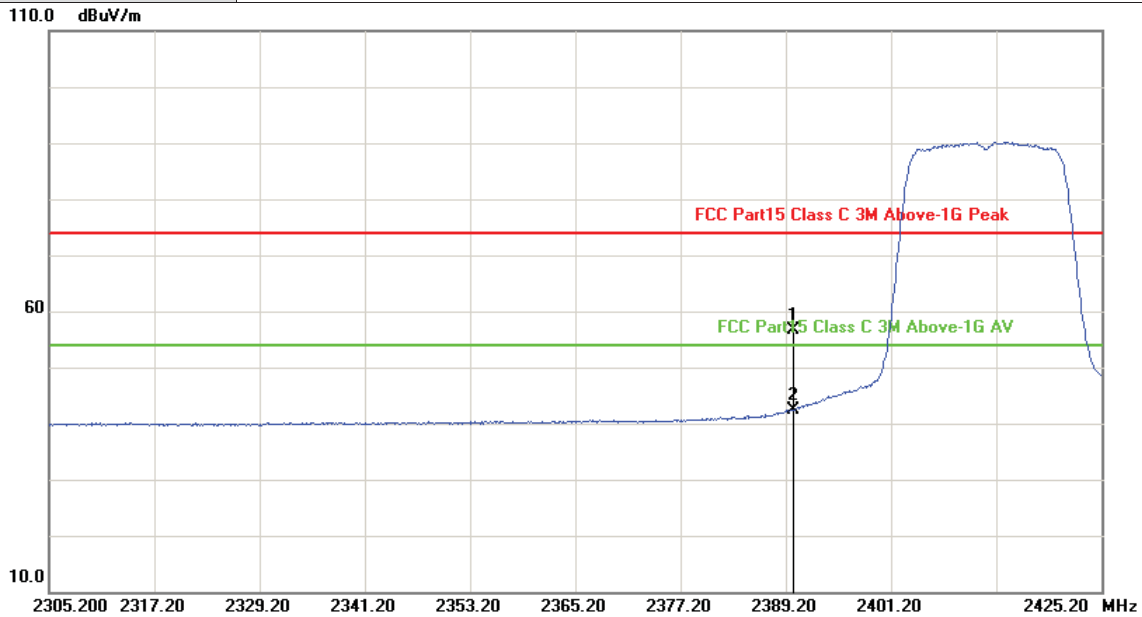

| No. | Frequency (MHz) | Factor (dB/m) | Reading (dBuV) | Level (dBuV/m) | Limit (dBuV/m) | Margin (dB) | Detector |
|-----|-----------------|---------------|----------------|----------------|----------------|-------------|----------|
| 1 | 2390.000 | 31.10 | 25.55 | 56.65 | 74.00 | -17.35 | peak |
| 2 | 2390.000 | 31.10 | 11.40 | 42.50 | 54.00 | -11.50 | AVG |

Remarks:

- Factor (dB/m) = Antenna Factor (dB/m)+Cable Factor (dB)-Pre-amplifier Factor
- Margin value = Level -Limit value



| | |
|------------|----------------------|
| Ant. Pol. | Vertical |
| Test Mode: | N(HT20) Mode 2412MHz |

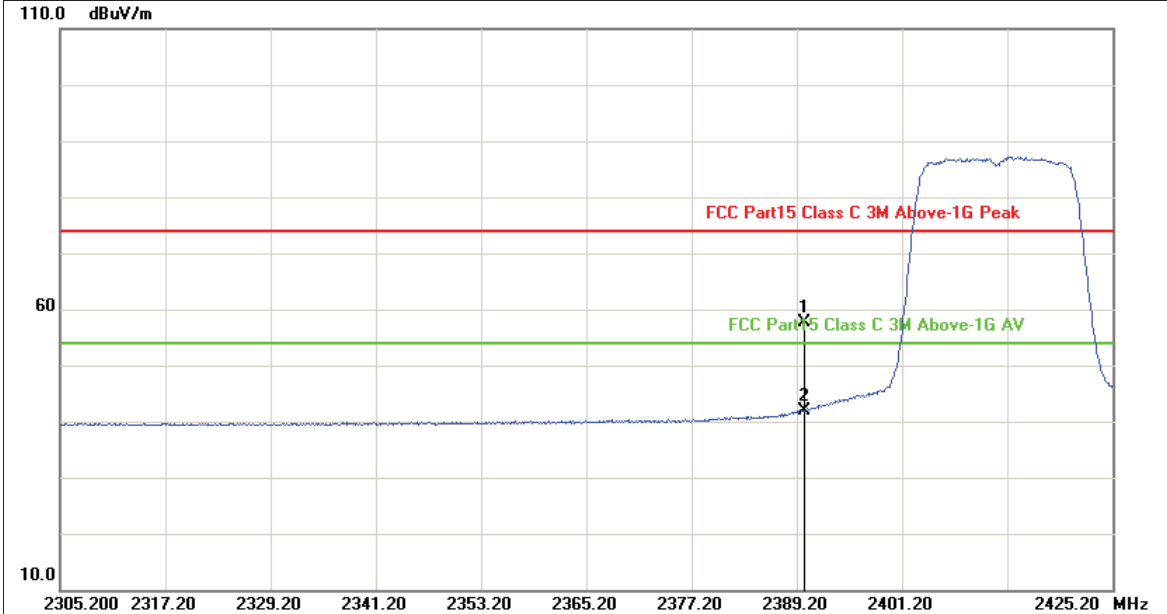

| No. | Frequency (MHz) | Factor (dB/m) | Reading (dBuV) | Level (dBuV/m) | Limit (dBuV/m) | Margin (dB) | Detector |
|-----|-----------------|---------------|----------------|----------------|----------------|-------------|----------|
| 1 | 2390.000 | 31.10 | 26.61 | 57.71 | 74.00 | -16.29 | peak |
| 2 | 2390.000 | 31.10 | 10.89 | 41.99 | 54.00 | -12.01 | AVG |

Remarks:
 1. Factor (dB/m) = Antenna Factor (dB/m)+Cable Factor (dB)-Pre-amplifier Factor
 2. Margin value = Level -Limit value



| | |
|------------|----------------------|
| Ant. Pol. | Horizontal |
| Test Mode: | N(HT20) Mode 2462MHz |

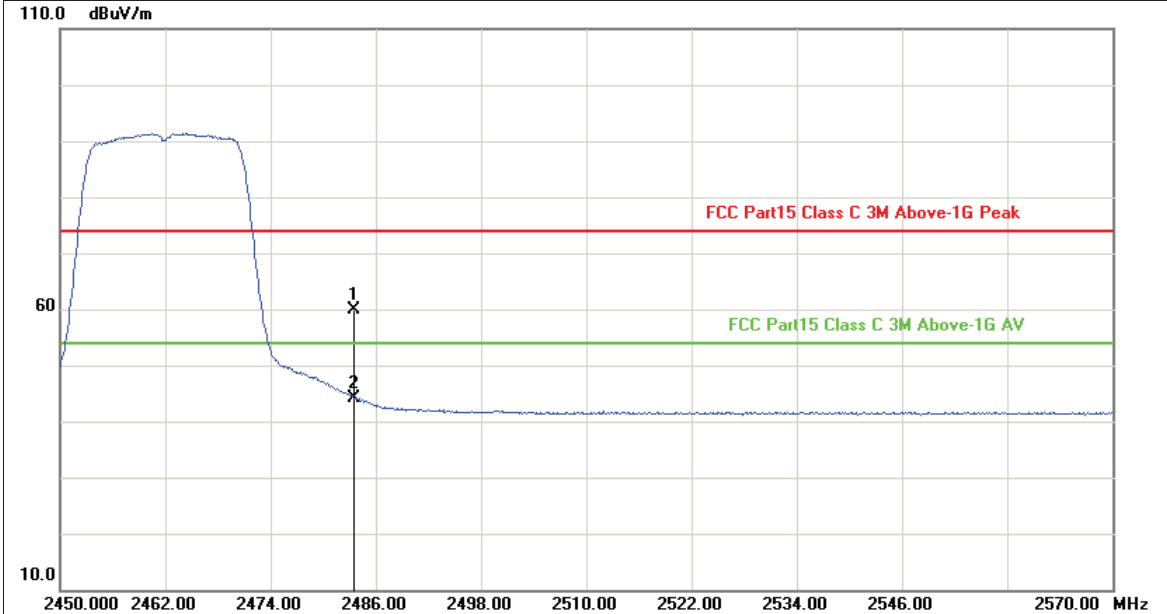

| No. | Frequency (MHz) | Factor (dB/m) | Reading (dBuV) | Level (dBuV/m) | Limit (dBuV/m) | Margin (dB) | Detector |
|-----|-----------------|---------------|----------------|----------------|----------------|-------------|----------|
| 1 | 2483.500 | 31.50 | 28.33 | 59.83 | 74.00 | -14.17 | peak |
| 2 | 2483.500 | 31.50 | 12.73 | 44.23 | 54.00 | -9.77 | AVG |

Remarks:

- Factor (dB/m) = Antenna Factor (dB/m)+Cable Factor (dB)-Pre-amplifier Factor
- Margin value = Level -Limit value



| | |
|------------|----------------------|
| Ant. Pol. | Vertical |
| Test Mode: | N(HT20) Mode 2462MHz |

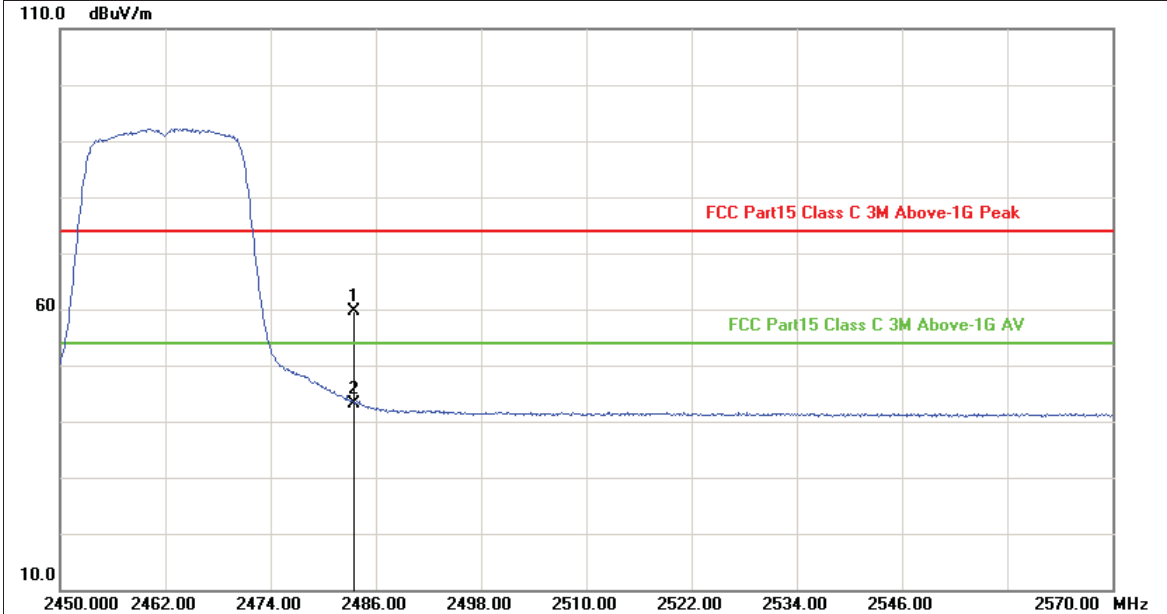

| No. | Frequency (MHz) | Factor (dB/m) | Reading (dBuV) | Level (dBuV/m) | Limit (dBuV/m) | Margin (dB) | Detector |
|-----|-----------------|---------------|----------------|----------------|----------------|-------------|----------|
| 1 | 2483.500 | 31.50 | 28.14 | 59.64 | 74.00 | -14.36 | peak |
| 2 | 2483.500 | 31.50 | 11.75 | 43.25 | 54.00 | -10.75 | AVG |

Remarks:

1. Factor (dB/m) = Antenna Factor (dB/m) + Cable Factor (dB) - Pre-amplifier Factor
2. Margin value = Level - Limit value



| | |
|------------|----------------------|
| Ant. Pol. | Horizontal |
| Test Mode: | N(HT40) Mode 2422MHz |

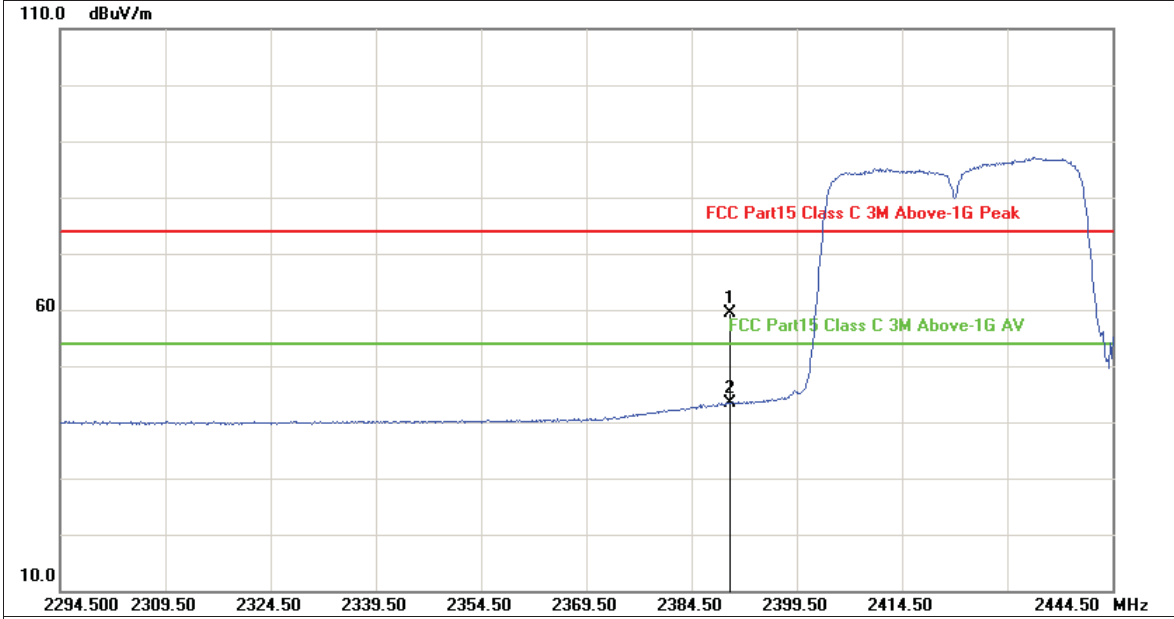

| No. | Frequency (MHz) | Factor (dB/m) | Reading (dBuV) | Level (dBuV/m) | Limit (dBuV/m) | Margin (dB) | Detector |
|-----|-----------------|---------------|----------------|----------------|----------------|-------------|----------|
| 1 | 2390.000 | 31.10 | 28.40 | 59.50 | 74.00 | -14.50 | peak |
| 2 | 2390.000 | 31.10 | 12.19 | 43.29 | 54.00 | -10.71 | AVG |

Remarks:
 1. Factor (dB/m) = Antenna Factor (dB/m)+Cable Factor (dB)-Pre-amplifier Factor
 2. Margin value = Level -Limit value



| | |
|------------|----------------------|
| Ant. Pol. | Vertical |
| Test Mode: | N(HT40) Mode 2422MHz |

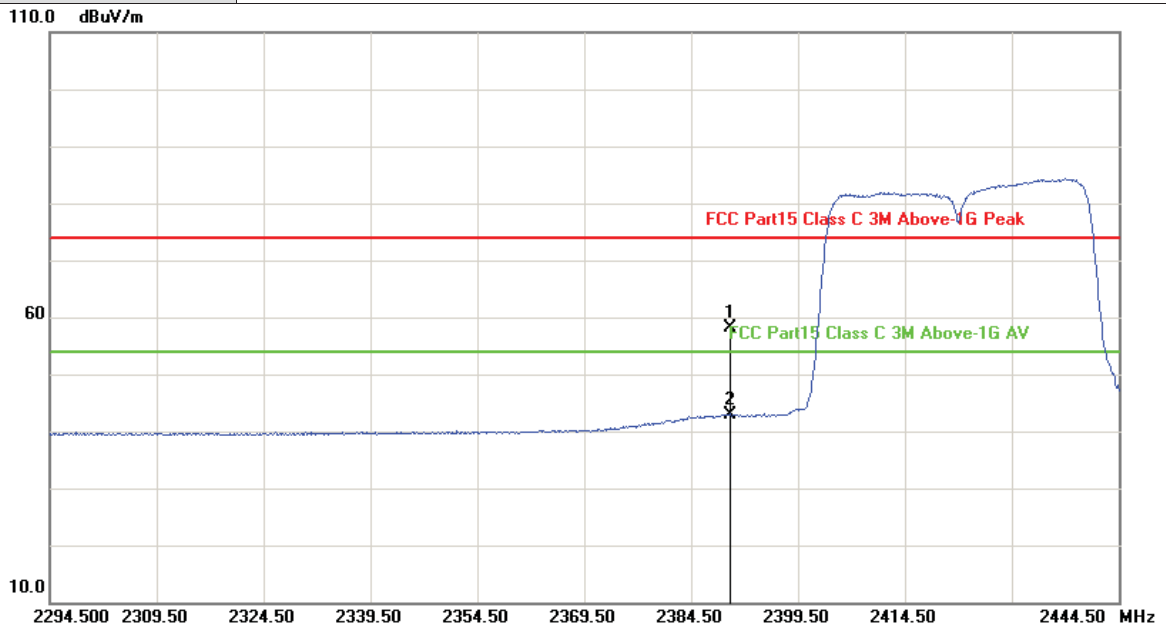

| No. | Frequency (MHz) | Factor (dB/m) | Reading (dBuV) | Level (dBuV/m) | Limit (dBuV/m) | Margin (dB) | Detector |
|-----|-----------------|---------------|----------------|----------------|----------------|-------------|----------|
| 1 | 2390.000 | 31.10 | 27.07 | 58.17 | 74.00 | -15.83 | peak |
| 2 | 2390.000 | 31.10 | 11.73 | 42.83 | 54.00 | -11.17 | AVG |

Remarks:

- 1. Factor (dB/m) = Antenna Factor (dB/m)+Cable Factor (dB)-Pre-amplifier Factor
- 2. Margin value = Level -Limit value



| | |
|------------|----------------------|
| Ant. Pol. | Horizontal |
| Test Mode: | N(HT40) Mode 2452MHz |

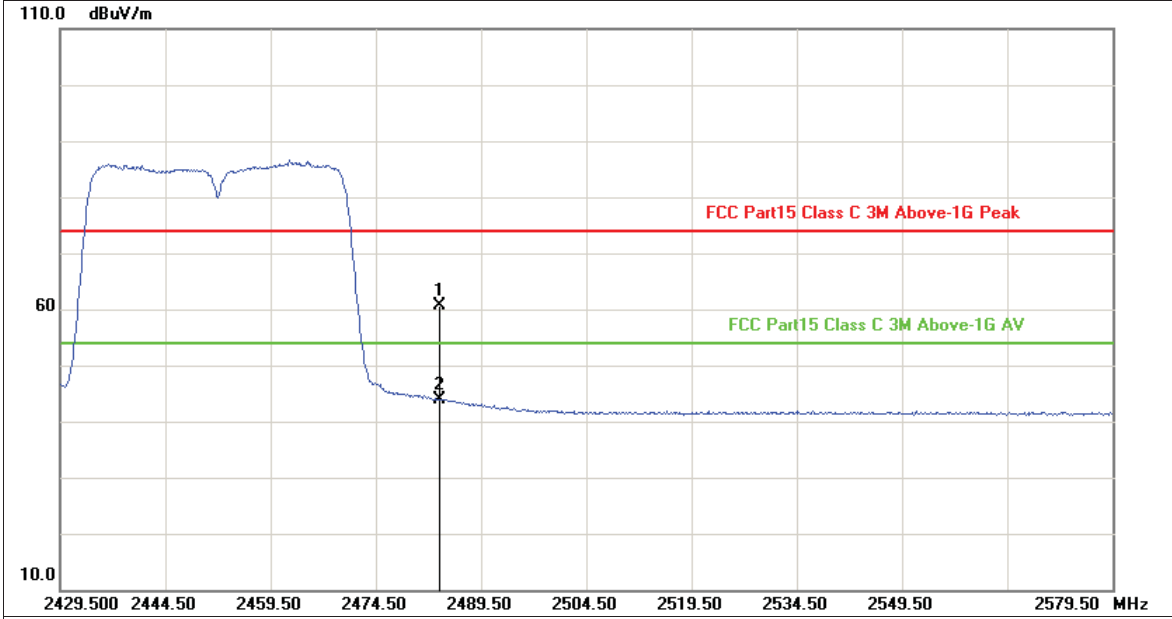

| No. | Frequency (MHz) | Factor (dB/m) | Reading (dBuV) | Level (dBuV/m) | Limit (dBuV/m) | Margin (dB) | Detector |
|-----|-----------------|---------------|----------------|----------------|----------------|-------------|----------|
| 1 | 2483.500 | 31.50 | 29.15 | 60.65 | 74.00 | -13.35 | peak |
| 2 | 2483.500 | 31.50 | 12.30 | 43.80 | 54.00 | -10.20 | AVG |

Remarks:

- Factor (dB/m) = Antenna Factor (dB/m)+Cable Factor (dB)-Pre-amplifier Factor
- Margin value = Level -Limit value



| | |
|------------|----------------------|
| Ant. Pol. | Vertical |
| Test Mode: | N(HT40) Mode 2452MHz |

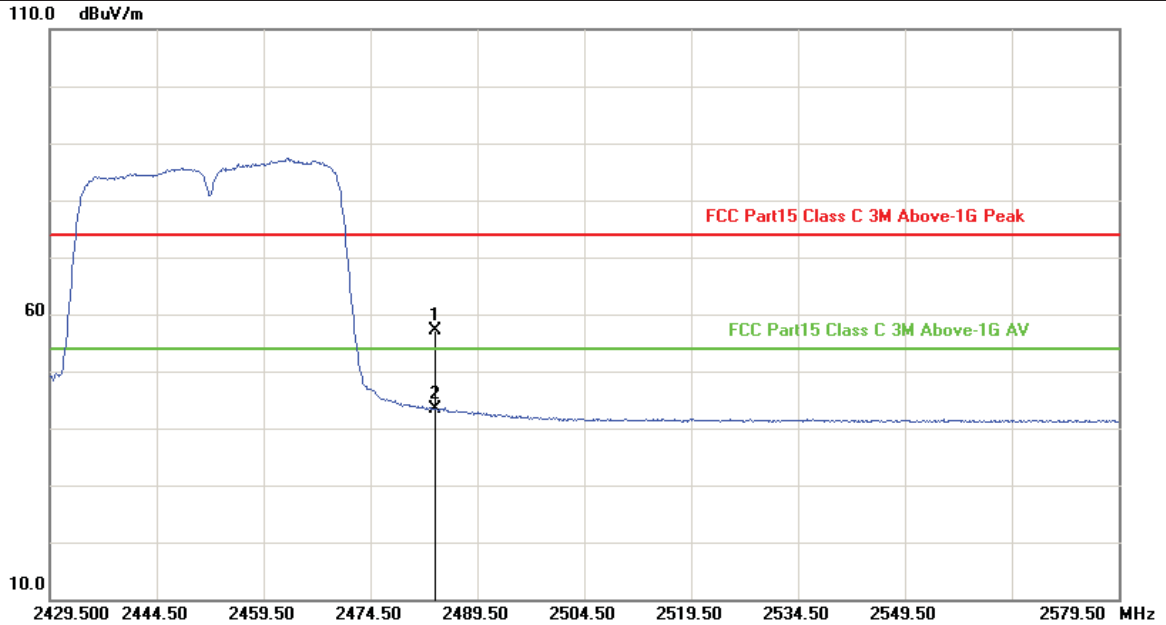

| No. | Frequency (MHz) | Factor (dB/m) | Reading (dBuV) | Level (dBuV/m) | Limit (dBuV/m) | Margin (dB) | Detector |
|-----|-----------------|---------------|----------------|----------------|----------------|-------------|----------|
| 1 | 2483.500 | 31.50 | 25.75 | 57.25 | 74.00 | -16.75 | peak |
| 2 | 2483.500 | 31.50 | 11.92 | 43.42 | 54.00 | -10.58 | AVG |

Remarks:

1. Factor (dB/m) = Antenna Factor (dB/m)+Cable Factor (dB)-Pre-amplifier Factor
2. Margin value = Level -Limit value



Conducted band edge data:

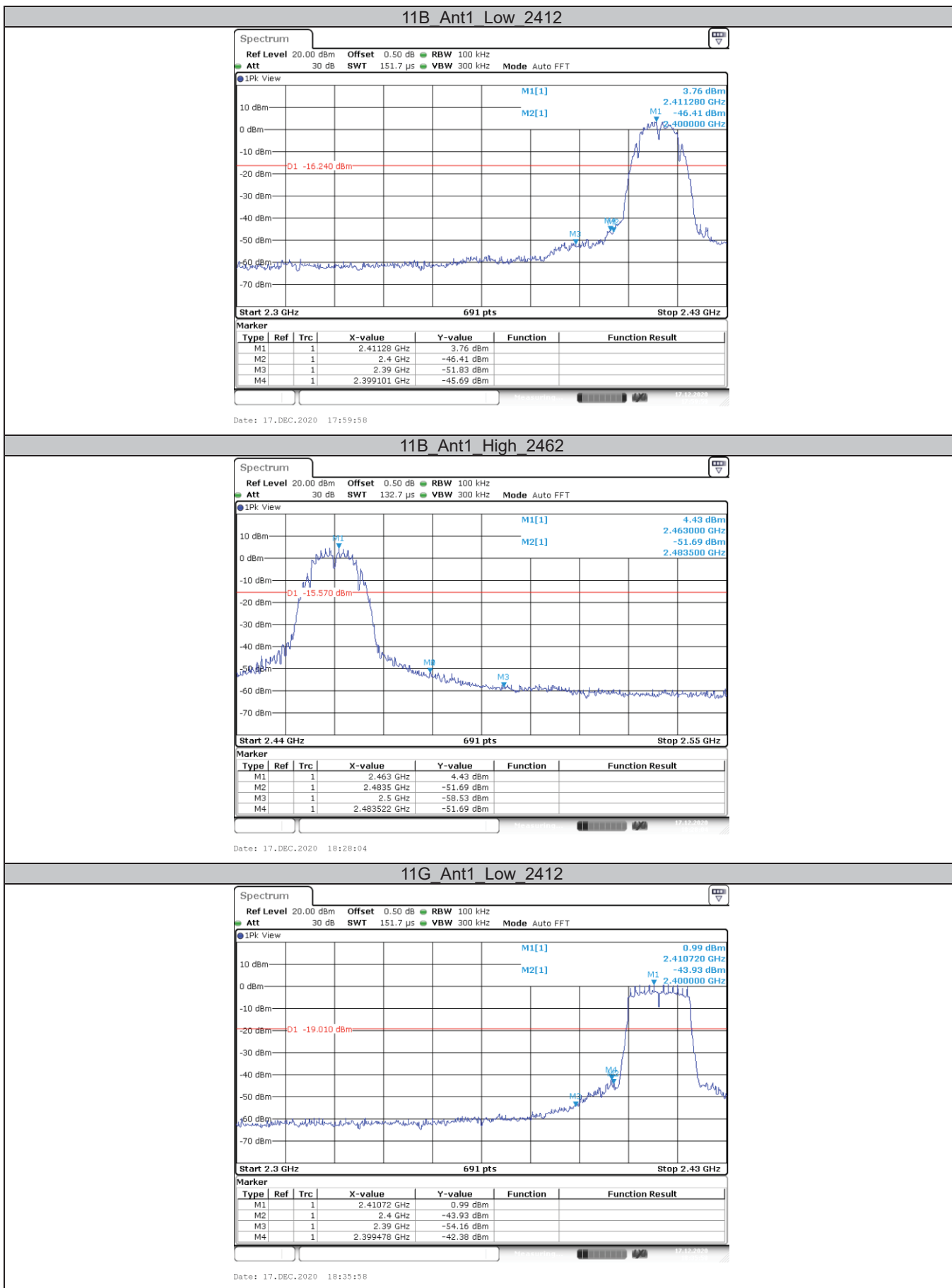

CTC Laboratories, Inc.

1-2/F., Building 2, Jiaquan Building, Guanlan High-Tech Park, Shenzhen, Guangdong, China
Tel.: (86)755-27521059

Fax: (86)755-27521011 [Http://www.sz-ctc.org.cn](http://www.sz-ctc.org.cn)



For anti-fake verification, please visit the official website of Certification and Accreditation Administration of the People's Republic of China : yz.cnca.cn



11G Ant1 High 2462

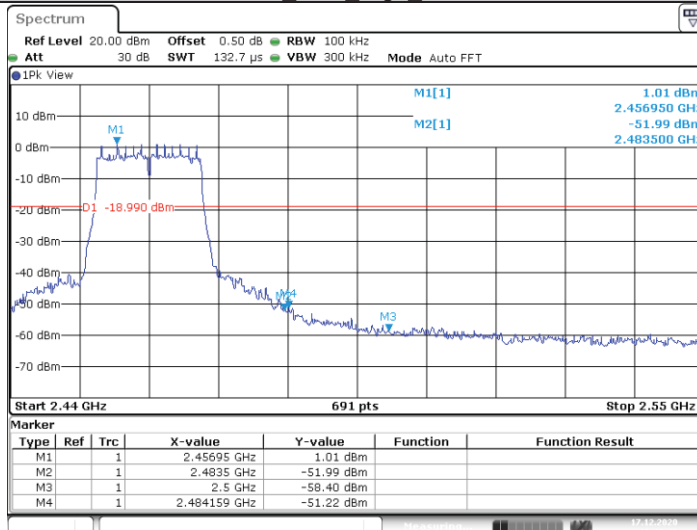

Date: 17.DEC.2020 18:42:46

11N20SISO Ant1 Low 2412

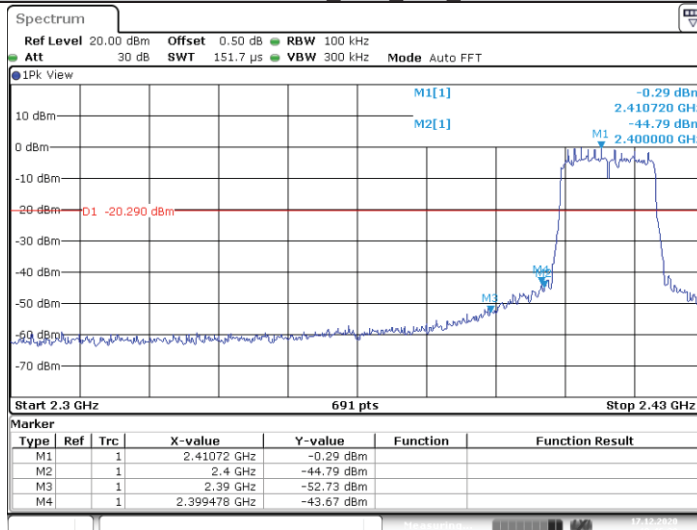

Date: 17.DEC.2020 18:46:28

11N20SISO Ant1 High 2462

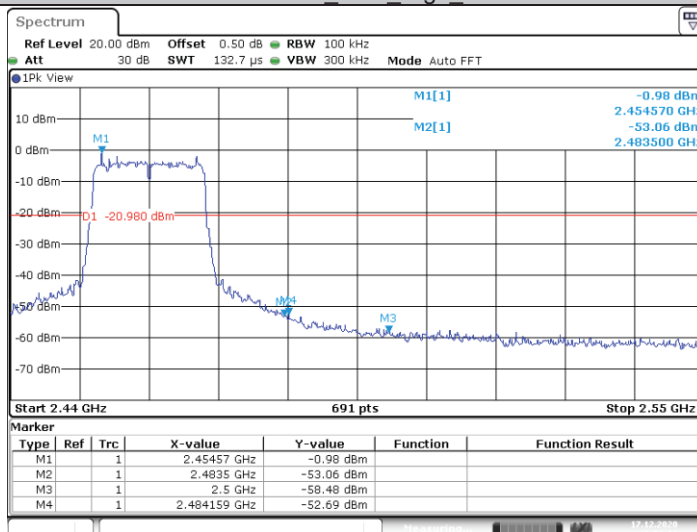

Date: 17.DEC.2020 18:52:30

CTC Laboratories, Inc.

1-2/F., Building 2, Jiaquan Building, Guanlan High-Tech Park, Shenzhen, Guangdong, China
Tel.: (86)755-27521059 Fax: (86)755-27521011 Http://www.sz-ctc.org.cn



For anti-fake verification, please visit the official website of Certification and Accreditation Administration of the People's Republic of China : yz.cnca.cn

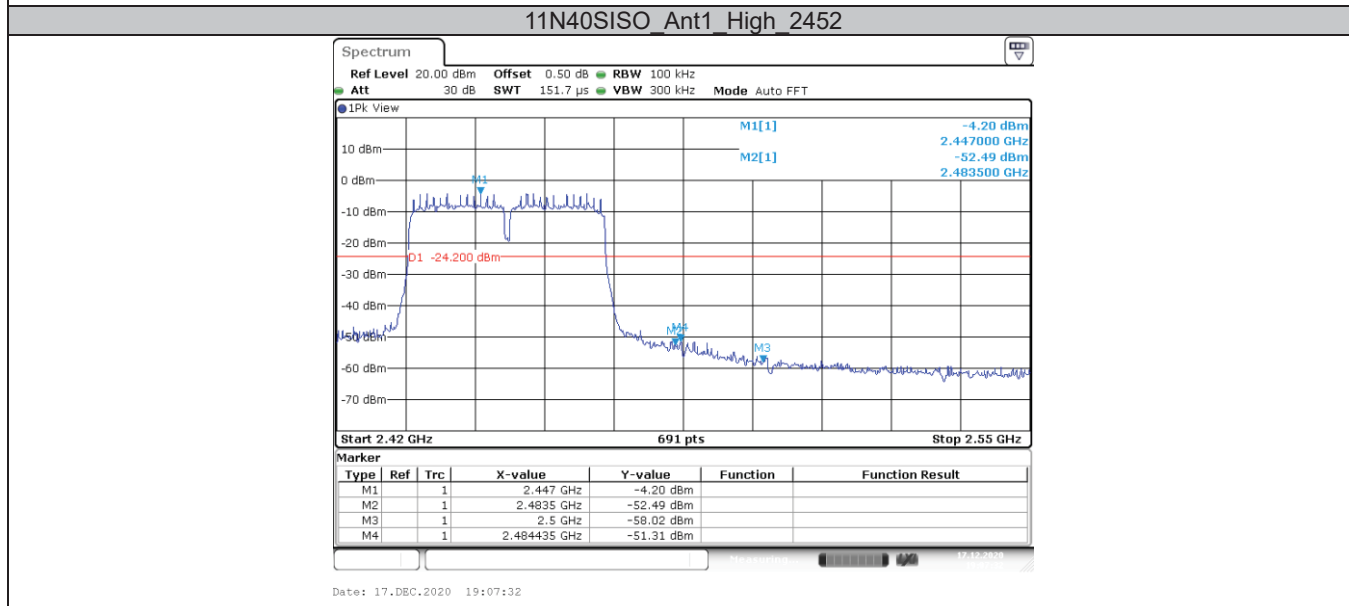
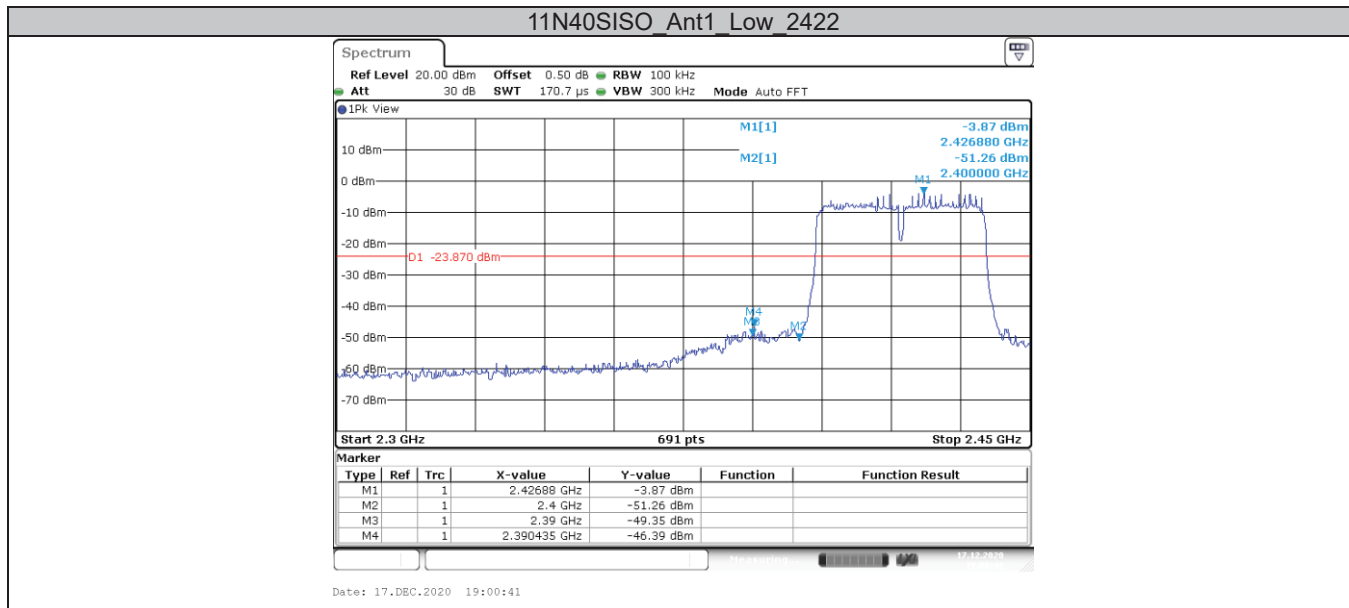



3.4. Bandwidth

Limit

FCC CFR Title 47 Part 15 Subpart C Section 15.247 (a)(2)

| Test Item | Limit | Frequency Range(MHz) |
|-----------|------------------------------|----------------------|
| Bandwidth | >=500 KHz (6dB bandwidth) | 2400~2483.5 |

Test Configuration

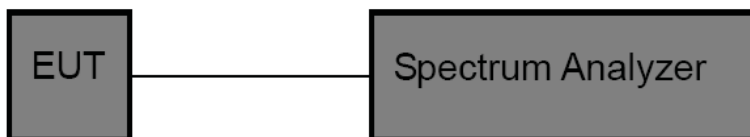

Test Procedure

- The EUT was directly connected to the spectrum analyzer and antenna output port as show in the block diagram above.
- DTS Spectrum Setting:
 - Set RBW = 100 kHz.
 - Set the video bandwidth (VBW) ≥ 3 RBW.
 - Detector = Peak.
 - Trace mode = Max hold.
 - Sweep = Auto couple.
- OCB Spectrum Setting:
 - Set RBW = 1% ~ 5% occupied bandwidth.
 - Set the video bandwidth (VBW) ≥ 3 RBW.
 - Detector = Peak.
 - Trace mode = Max hold.
 - Sweep = Auto couple.

NOTE: The EUT was set to continuously transmitting in each mode and low, Middle and high channel for the test.

Test Mode

Please refer to the clause 2.3.

Test Results

Please see the Appendix A1, A2.



3.5. Peak Output Power

Limit

FCC CFR Title 47 Part 15 Subpart C Section 15.247 (b)(3)/ RSS-247 5.4:

| Section | Test Item | Limit | Frequency Range(MHz) |
|-------------------------|--------------------------------|-----------------|----------------------|
| CFR 47 FCC 15.247(b)(3) | Maximum conducted output power | 1 Watt or 30dBm | 2400~2483.5 |
| ISED RSS-247 5.4 d | EIRP | 4 Watt or 36dBm | 2400~2483.5 |

Test Configuration

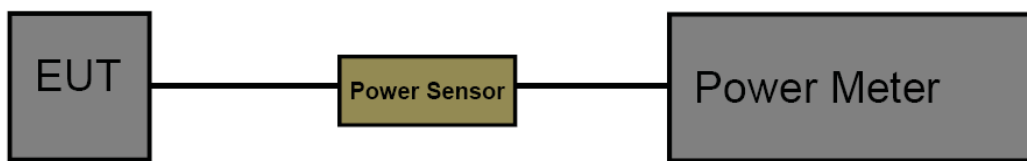

Test Procedure

1. The maximum conducted output power may be measured using a broadband Peak RF power meter.
2. Peak power measurements were performed only when the EUT was transmitting at its maximum power control level using a broadband power meter with a pulse sensor.
3. The power meter implemented triggering and gating capabilities which were set up such that power measurements were recorded only during the ON time of the transmitter.
4. Record the measurement data.

Test Mode

Please refer to the clause 2.3

Test Result



| TestMode | Antenna | Channel | Result[dBm] | Limit[dBm] | Verdict |
|-----------|---------|---------|-------------|------------|---------|
| 11B | Ant1 | 2412 | 16.51 | <=30 | PASS |
| | | 2437 | 16.45 | <=30 | PASS |
| | | 2462 | 16.27 | <=30 | PASS |
| 11G | Ant1 | 2412 | 19.10 | <=30 | PASS |
| | | 2437 | 19.37 | <=30 | PASS |
| | | 2462 | 19.22 | <=30 | PASS |
| 11N20SISO | Ant1 | 2412 | 18.26 | <=30 | PASS |
| | | 2437 | 18.04 | <=30 | PASS |
| | | 2462 | 17.99 | <=30 | PASS |
| 11N40SISO | Ant1 | 2422 | 17.34 | <=30 | PASS |
| | | 2437 | 17.10 | <=30 | PASS |
| | | 2452 | 17.06 | <=30 | PASS |

Note: Test results increased RF cable loss by 0.5dB.

3.6. Power Spectral Density

Limit

FCC CFR Title 47 Part 15 Subpart C Section 15.247 (e):

| Test Item | Limit | Frequency Range(MHz) |
|------------------------|--------------------|----------------------|
| Power Spectral Density | 8dBm(in any 3 kHz) | 2400~2483.5 |

Test Configuration

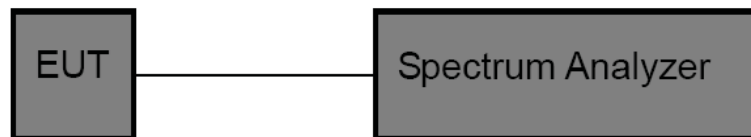

Test Procedure

1. The EUT was directly connected to the spectrum analyzer and antenna output port as show in the block diagram above.
2. The EUT was directly connected to the Spectrum Analyzer and antenna output port as show in the block diagram above. The measurement according to section 10.2 of KDB 558074 D01 DTS Meas Guidance v05r02.
3. Spectrum Setting:
Set analyzer center frequency to DTS channel center frequency.
Set the span to 1.5 times the DTS bandwidth.
Set the RBW to: 3 kHz
Set the VBW to: 10 kHz
Detector: peak
Sweep time: auto
Allow trace to fully stabilize. Then use the peak marker function to determine the maximum amplitude level.

Test Mode

Please refer to the clause 2.3

Test Result

Please see the Appendix B.

Note : Duty Cycle Correction Factor = $10 \cdot \log(1/\text{duty cycle})$
The Duty Cycle Correction Factor is compensated in the graph.



3.7. Antenna requirement

Requirement

FCC CFR Title 47 Part 15 Subpart C Section 15.203:

An intentional radiator shall be designed to ensure that no antenna other than that furnished by the responsible party shall be used with the device. The use of a permanently attached antenna or of antenna that uses a unique coupling to the intentional radiator, the manufacturer may design the unit so that a broken antenna can be replaced by the user, but the use of a standard antenna jack or electrical connector is prohibited.

FCC CFR Title 47 Part 15 Subpart C Section 15.247(c) (1)(i):

(i) Systems operating in the 2400~2483.5 MHz band that is used exclusively for fixed. Point-to-point operations may employ transmitting antennas with directional gain greater than 6dBi provided the maximum conducted output power of the intentional radiator is reduced by 1 dB for every 3 dB that the directional gain of the antenna exceeds 6dBi.

Test Result

The directional gain of the antenna less than 6dBi, please refer to the EUT internal photographs antenna photo.



Appendix A1: DTS Bandwidth

Test Result

| TestMode | Antenna | Channel | DTS BW [MHz] | FL[MHz] | FH[MHz] | Limit[MHz] | Verdict |
|-----------|---------|---------|--------------|----------|----------|------------|---------|
| 11B | Ant1 | 2412 | 10.120 | 2406.920 | 2417.040 | >=0.5 | PASS |
| | | 2437 | 10.120 | 2431.920 | 2442.040 | >=0.5 | PASS |
| | | 2462 | 10.120 | 2456.920 | 2467.040 | >=0.5 | PASS |
| 11G | Ant1 | 2412 | 16.360 | 2403.800 | 2420.160 | >=0.5 | PASS |
| | | 2437 | 16.440 | 2428.760 | 2445.200 | >=0.5 | PASS |
| | | 2462 | 16.440 | 2453.760 | 2470.200 | >=0.5 | PASS |
| 11N20SISO | Ant1 | 2412 | 17.120 | 2403.440 | 2420.560 | >=0.5 | PASS |
| | | 2437 | 17.160 | 2428.400 | 2445.560 | >=0.5 | PASS |
| | | 2462 | 17.240 | 2453.320 | 2470.560 | >=0.5 | PASS |
| 11N40SISO | Ant1 | 2422 | 35.360 | 2404.320 | 2439.680 | >=0.5 | PASS |
| | | 2437 | 35.360 | 2419.320 | 2454.680 | >=0.5 | PASS |
| | | 2452 | 35.360 | 2434.320 | 2469.680 | >=0.5 | PASS |



Test Graphs

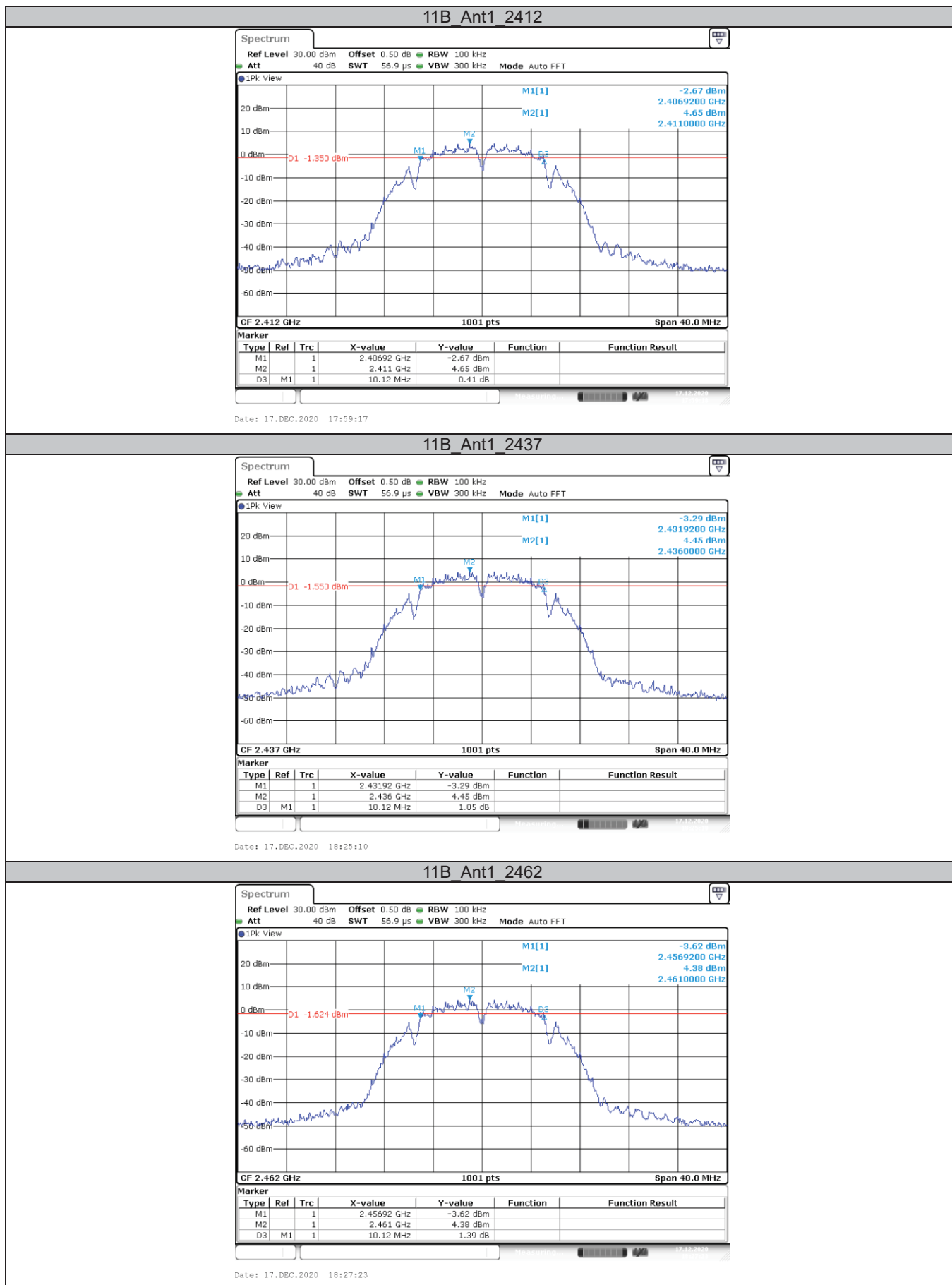

CTC Laboratories, Inc.

1-2/F., Building 2, Jiaquan Building, Guanlan High-Tech Park, Shenzhen, Guangdong, China
 Tel.: (86)755-27521059 Fax: (86)755-27521011 Http://www.sz-ctc.org.cn



For anti-fake verification, please visit the official website of Certification and Accreditation Administration of the People's Republic of China : yz.cnca.cn



11G Ant1_2412

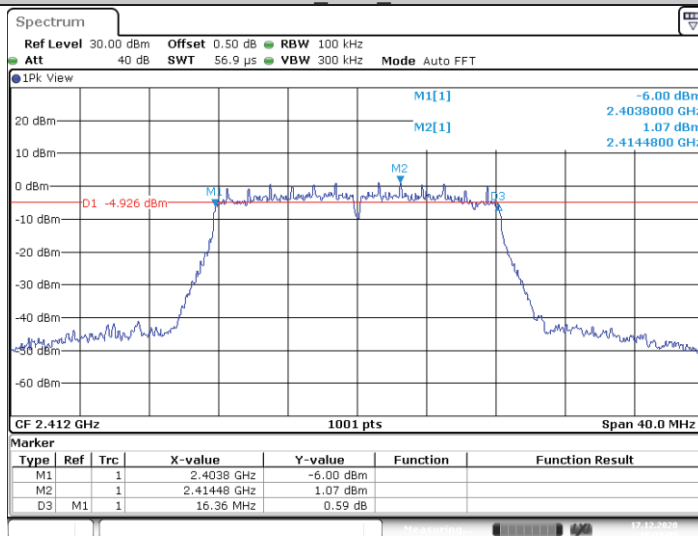

Date: 17.DEC.2020 18:31:03

11G Ant1_2437

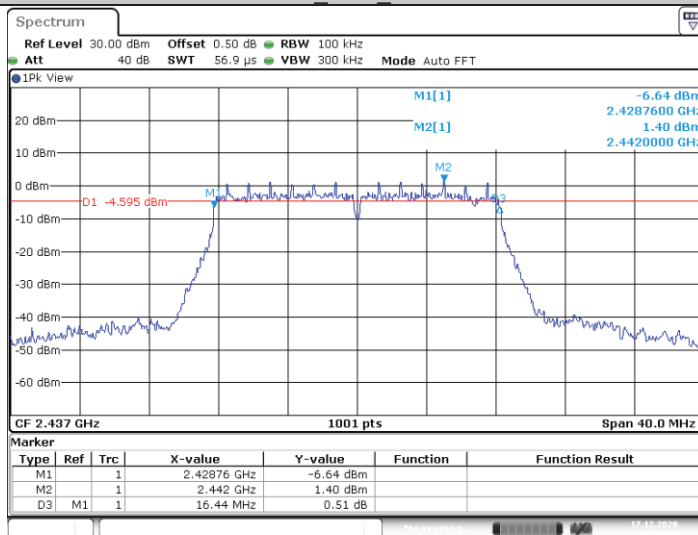

Date: 17.DEC.2020 18:39:36

11G Ant1_2462

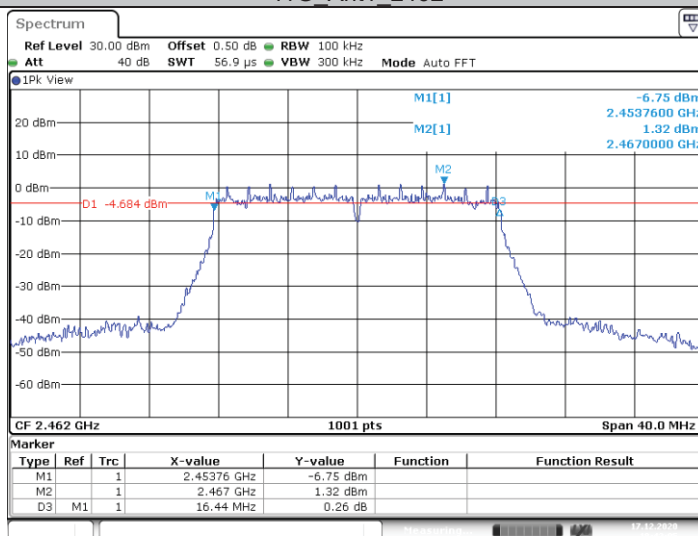

Date: 17.DEC.2020 18:42:05

CTC Laboratories, Inc.

1-2/F., Building 2, Jiaquan Building, Guanlan High-Tech Park, Shenzhen, Guangdong, China
Tel.: (86)755-27521059 Fax: (86)755-27521011 Http://www.sz-ctc.org.cn



For anti-fake verification, please visit the official website of Certification and Accreditation Administration of the People's Republic of China : yz.cnca.cn

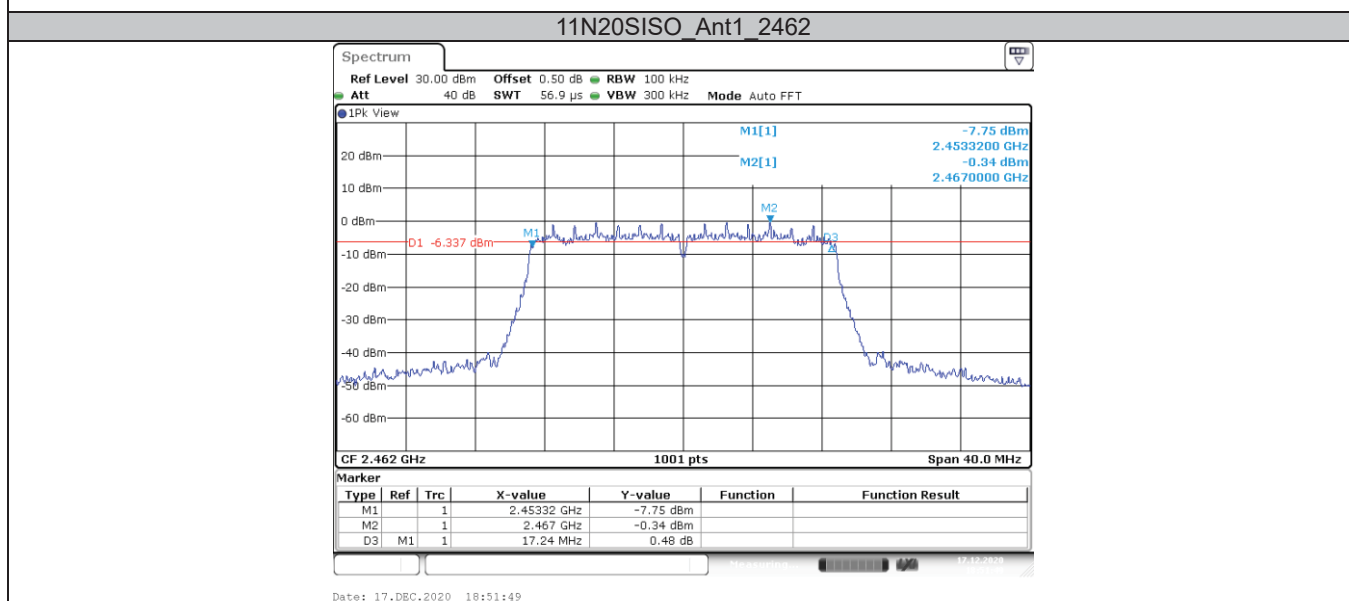
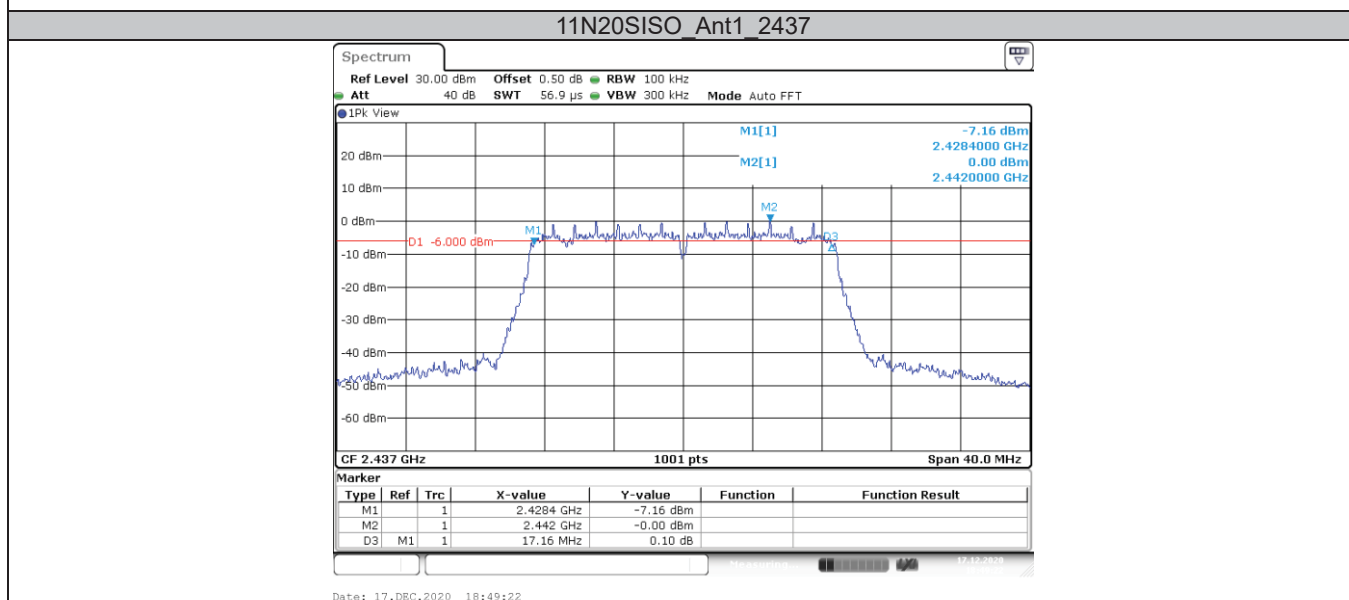
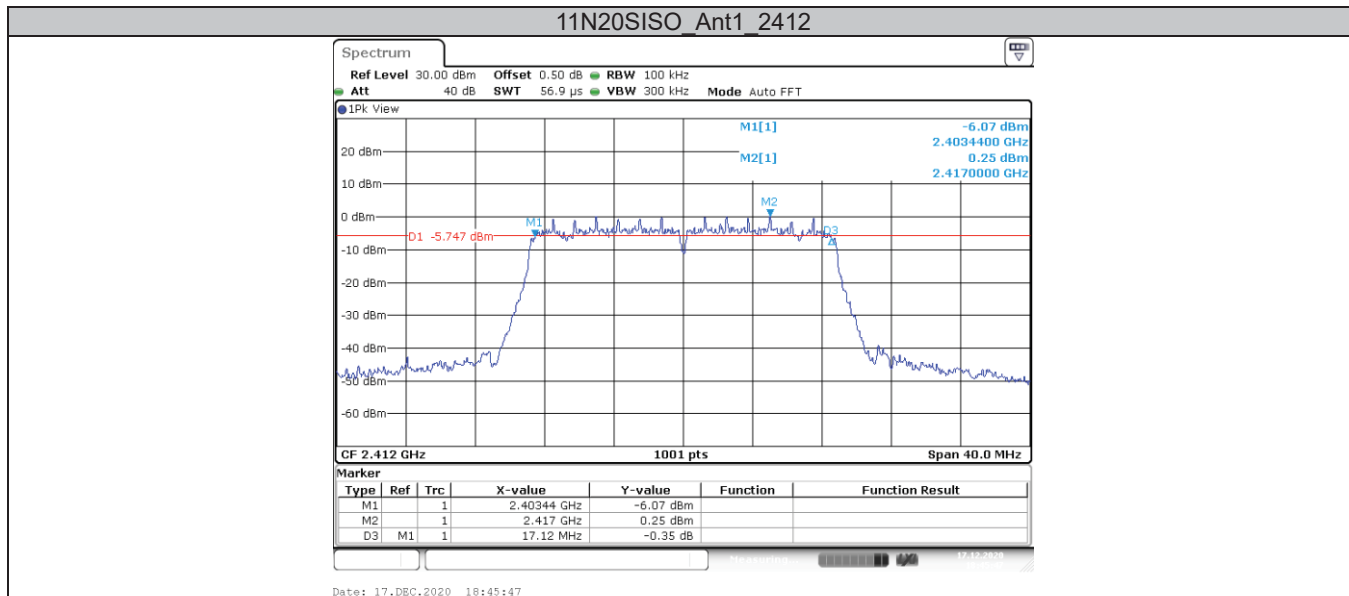

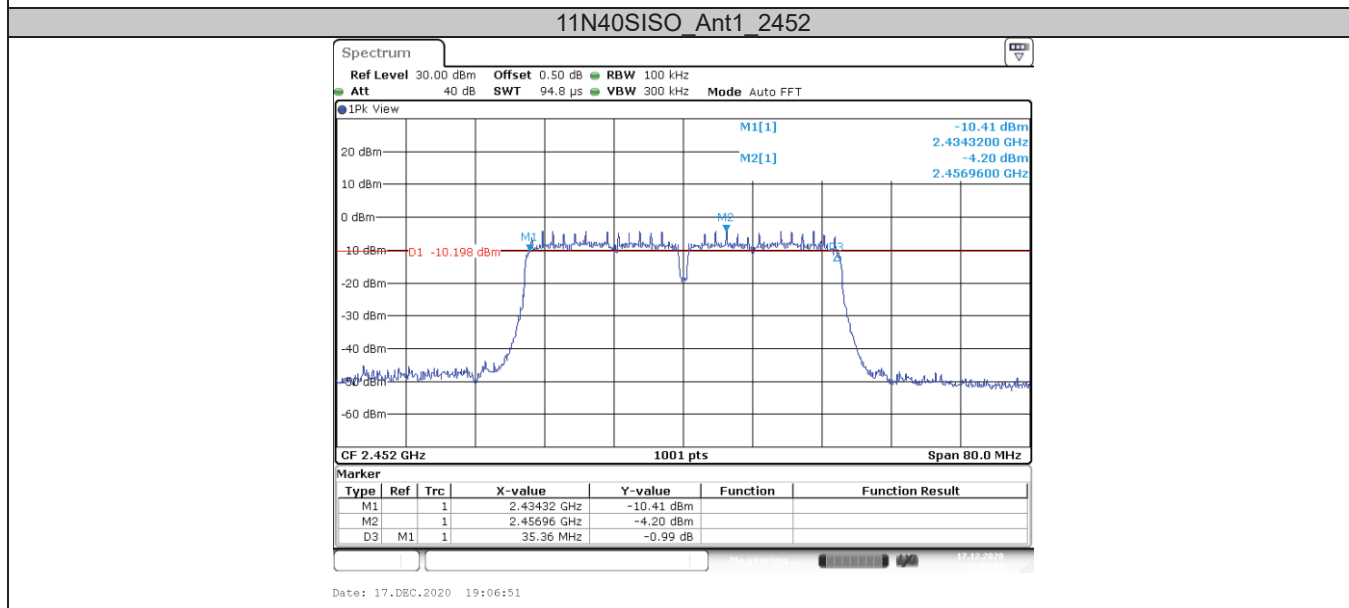
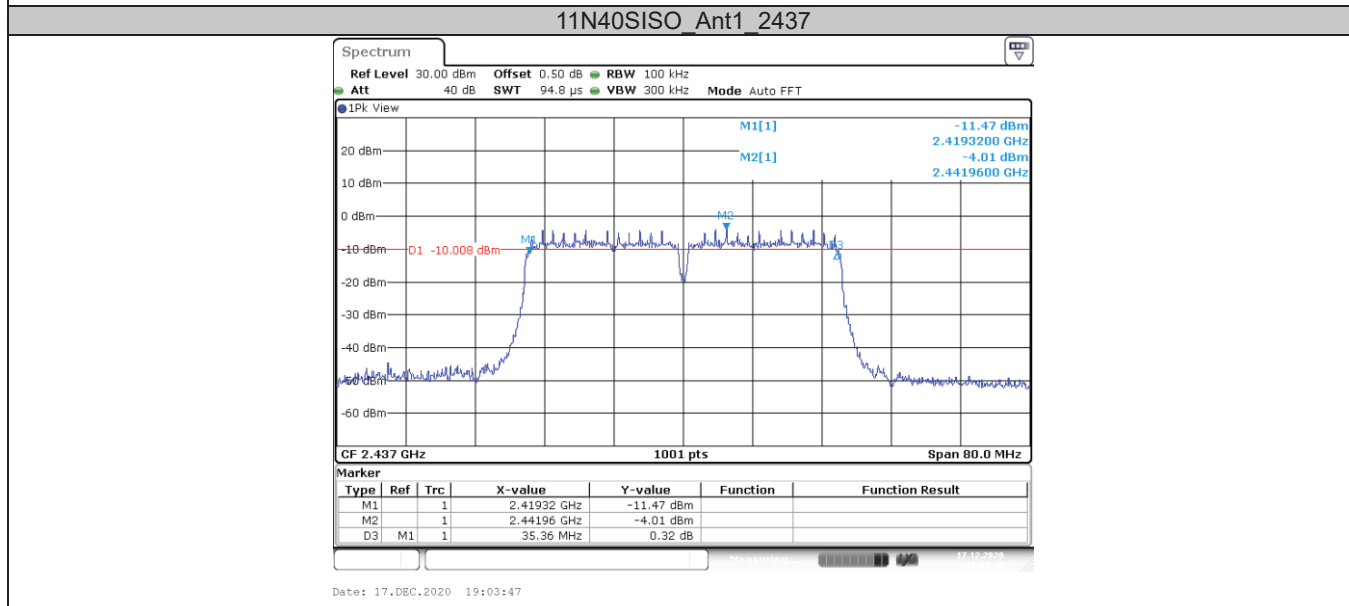
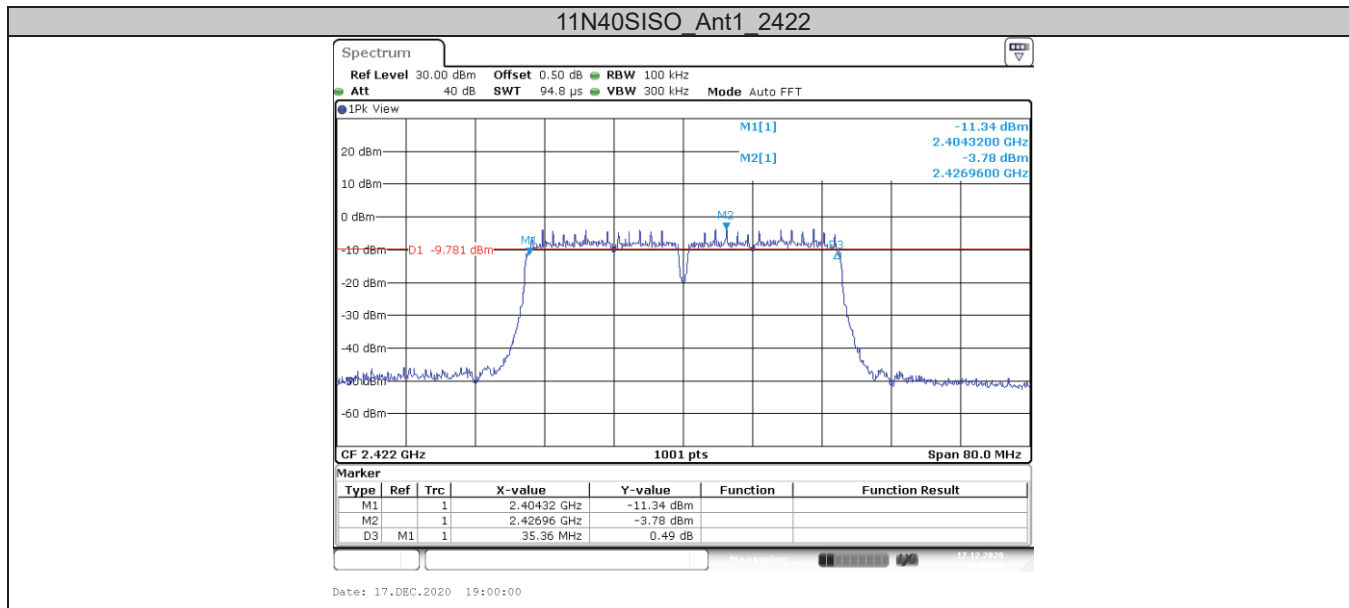



Appendix A2: Occupied Channel Bandwidth

Test Result

| TestMode | Antenna | Channel | OCB [MHz] | Limit[MHz] | Verdict |
|-----------|---------|---------|-----------|------------|---------|
| 11B | Ant1 | 2412 | 12.787 | ≥ 0.5 | PASS |
| | | 2437 | 12.827 | ≥ 0.5 | PASS |
| | | 2462 | 12.867 | ≥ 0.5 | PASS |
| 11G | Ant1 | 2412 | 16.703 | ≥ 0.5 | PASS |
| | | 2437 | 16.903 | ≥ 0.5 | PASS |
| | | 2462 | 16.863 | ≥ 0.5 | PASS |
| 11N20SISO | Ant1 | 2412 | 17.742 | ≥ 0.5 | PASS |
| | | 2437 | 17.702 | ≥ 0.5 | PASS |
| | | 2462 | 17.742 | ≥ 0.5 | PASS |
| 11N40SISO | Ant1 | 2422 | 35.964 | ≥ 0.5 | PASS |
| | | 2437 | 35.884 | ≥ 0.5 | PASS |
| | | 2452 | 35.964 | ≥ 0.5 | PASS |



Test Graphs

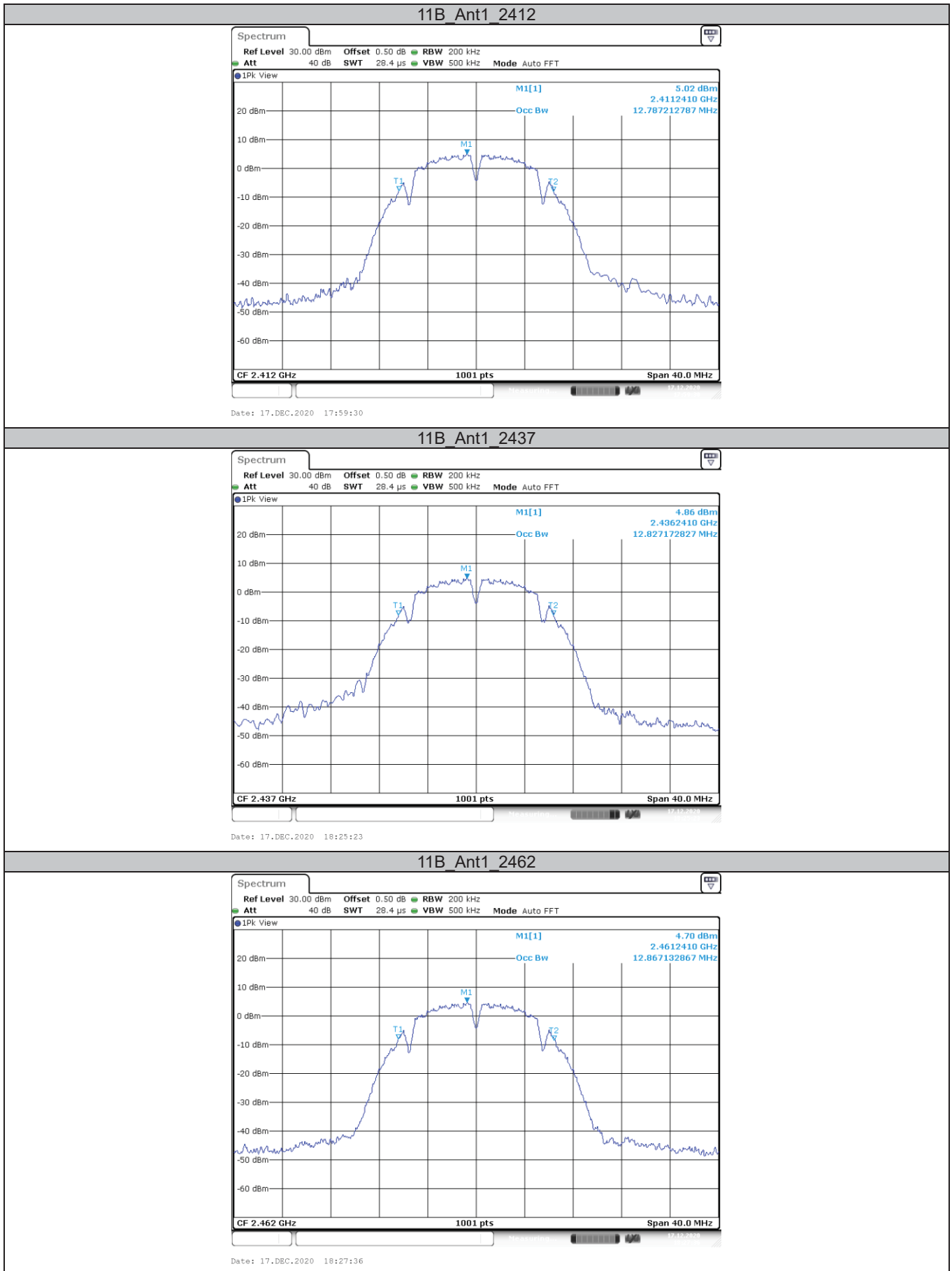

CTC Laboratories, Inc.

1-2/F., Building 2, Jiaquan Building, Guanlan High-Tech Park, Shenzhen, Guangdong, China
Tel.: (86)755-27521059

Fax: (86)755-27521011 Http://www.sz-ctc.org.cn



For anti-fake verification, please visit the official website of Certification and Accreditation Administration of the People's Republic of China : yz.cnca.cn



11G Ant1_2412

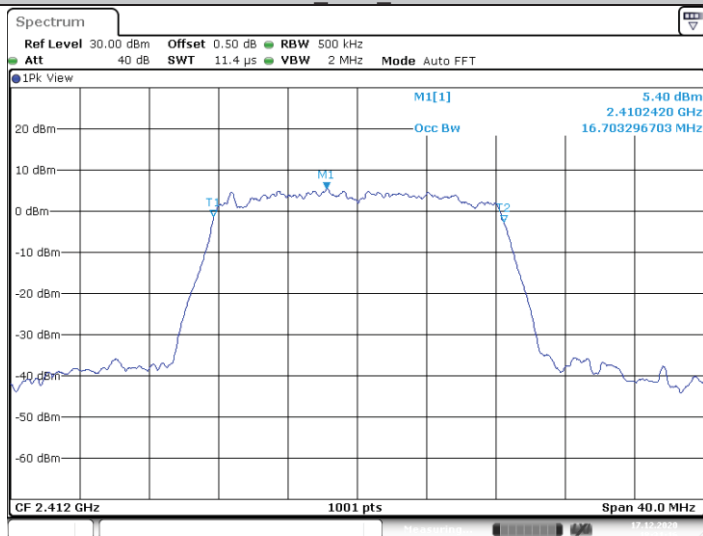

Date: 17.DEC.2020 18:31:16

11G Ant1_2437

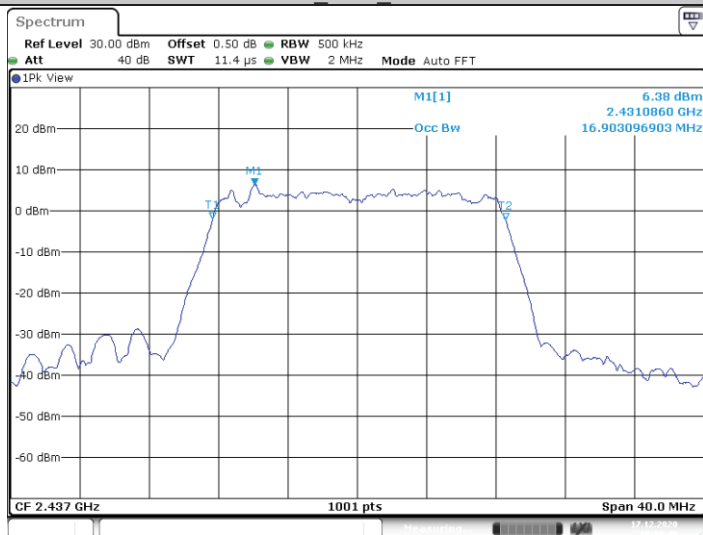

Date: 17.DEC.2020 18:39:49

11G Ant1_2462

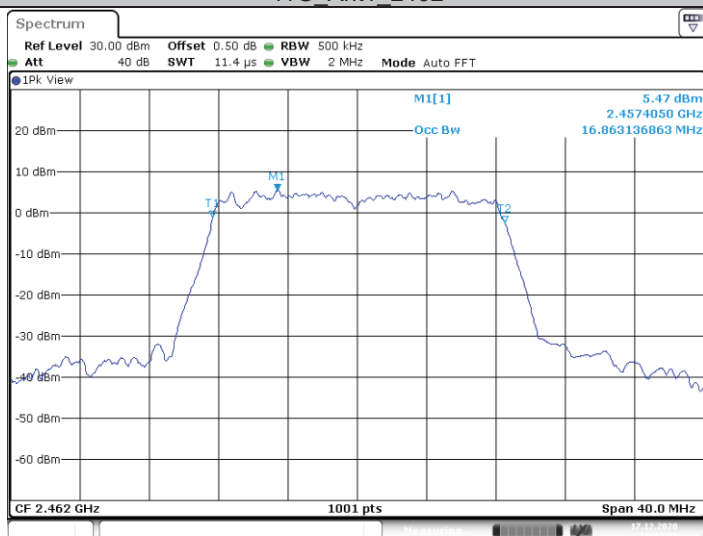

Date: 17.DEC.2020 18:42:18

CTC Laboratories, Inc.

1-2/F., Building 2, Jiaquan Building, Guanlan High-Tech Park, Shenzhen, Guangdong, China
Tel.: (86)755-27521059

Fax: (86)755-27521011 Http://www.sz-ctc.org.cn
For anti-fake verification, please visit the official website of Certification and Accreditation Administration of the People's Republic of China : yz.cnca.cn



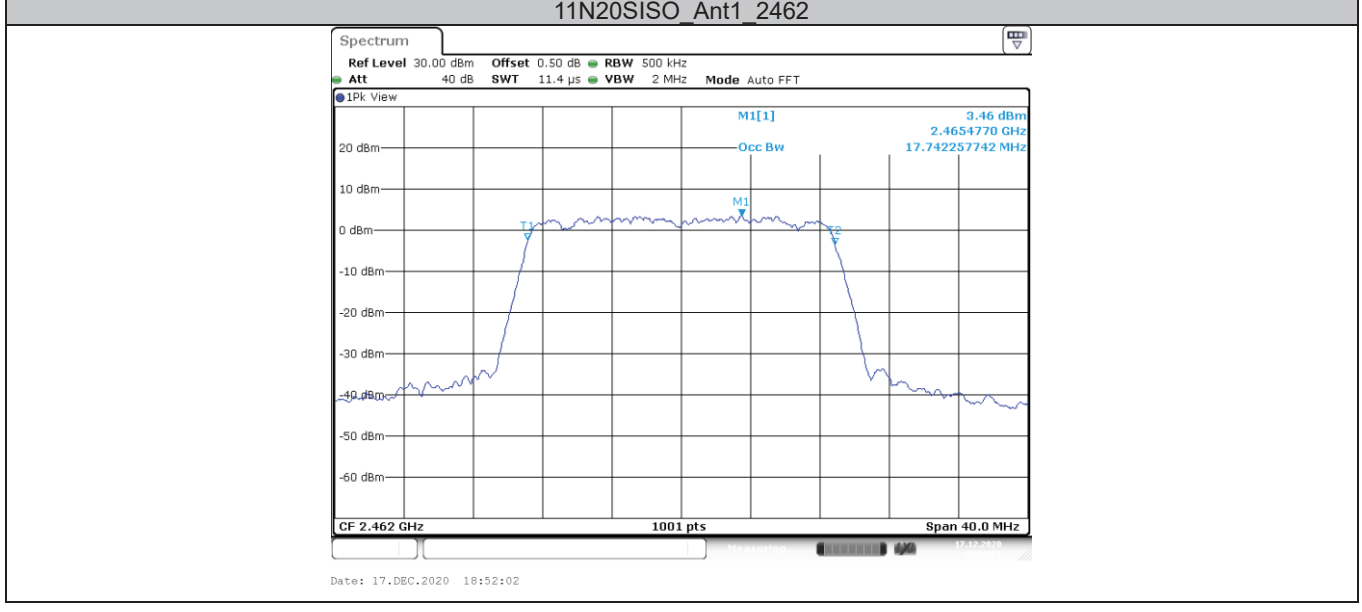
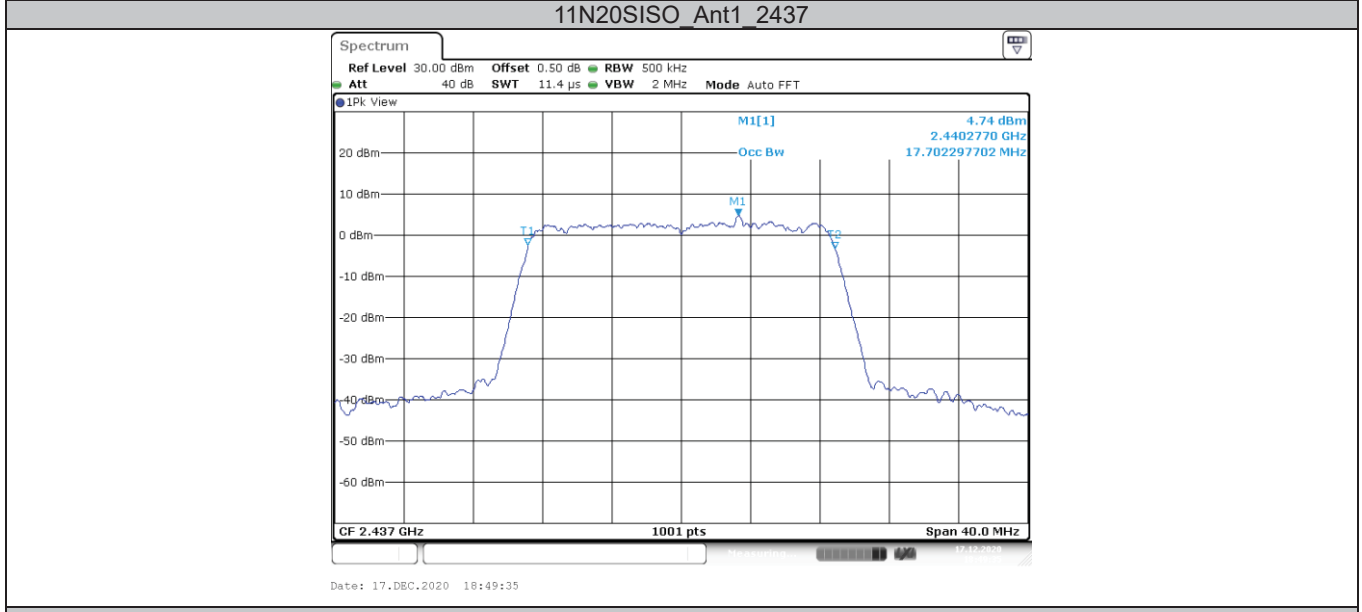
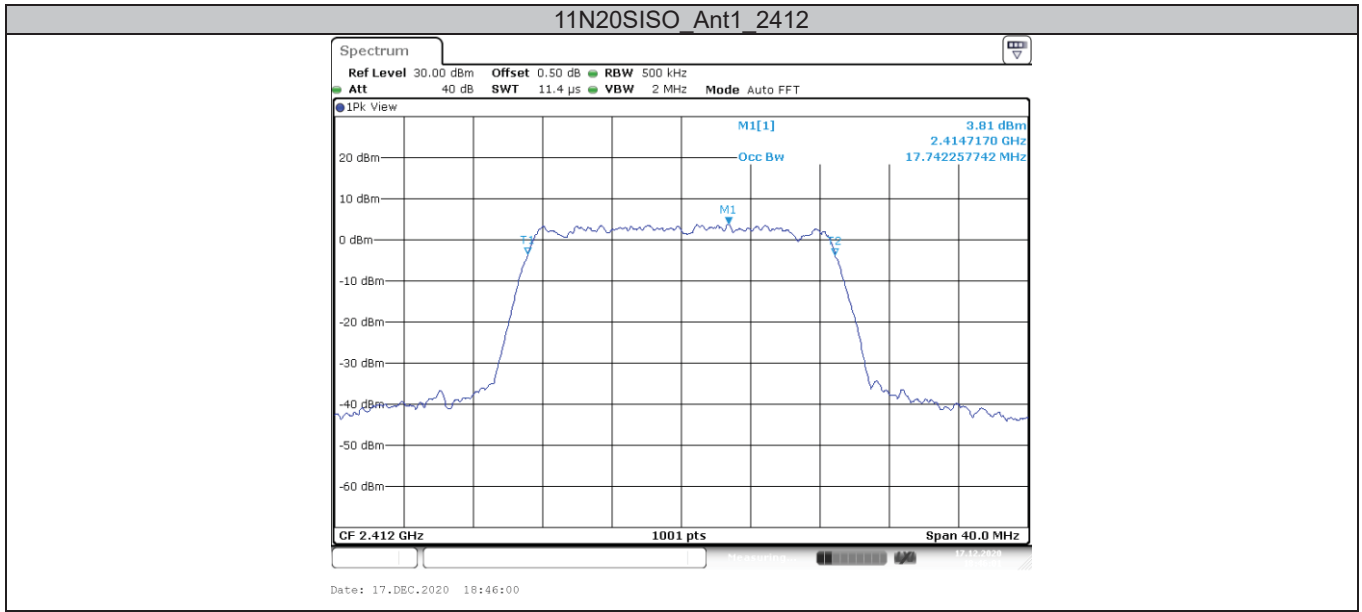

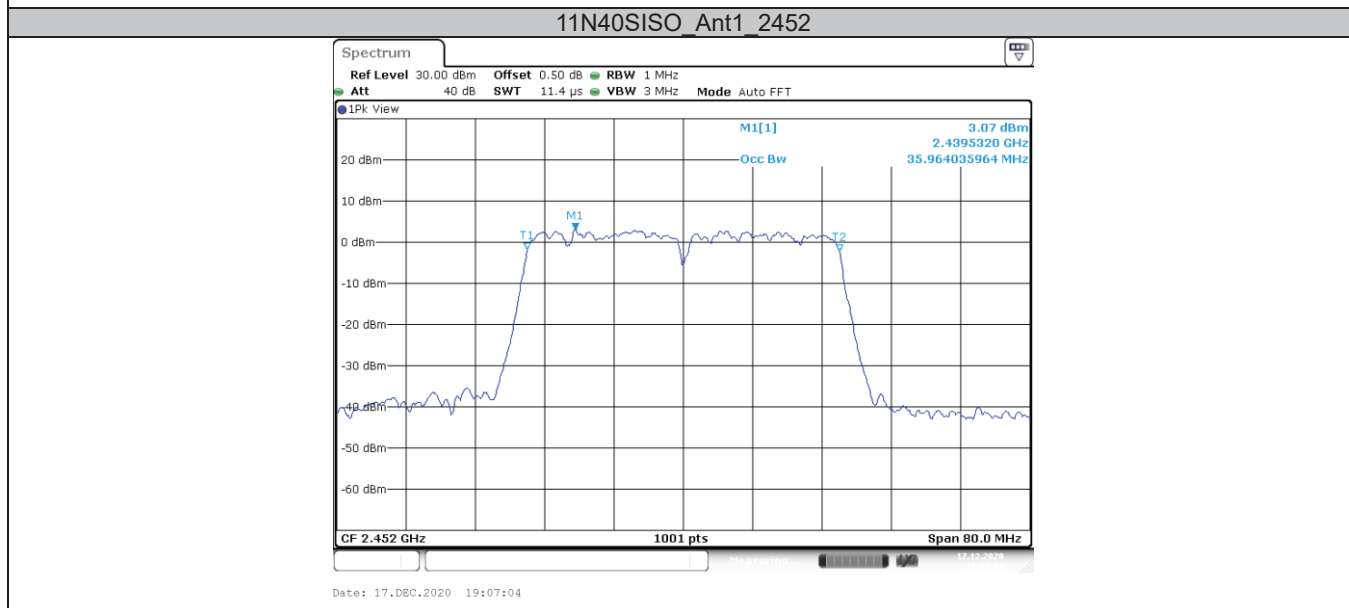
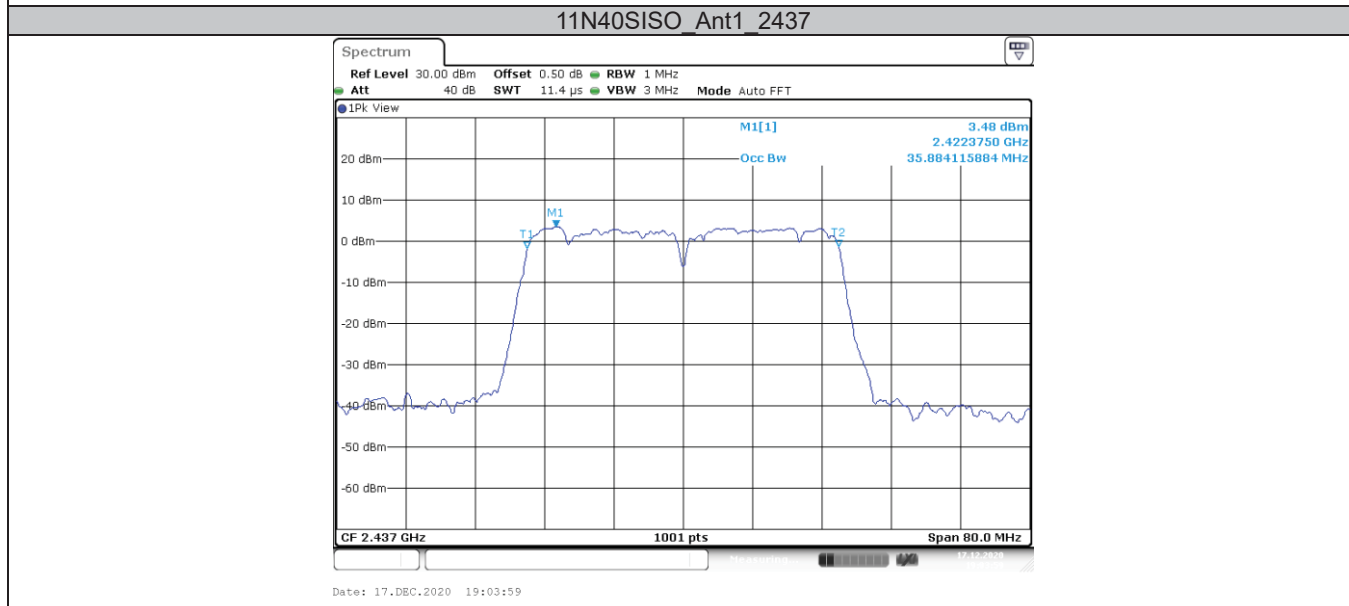
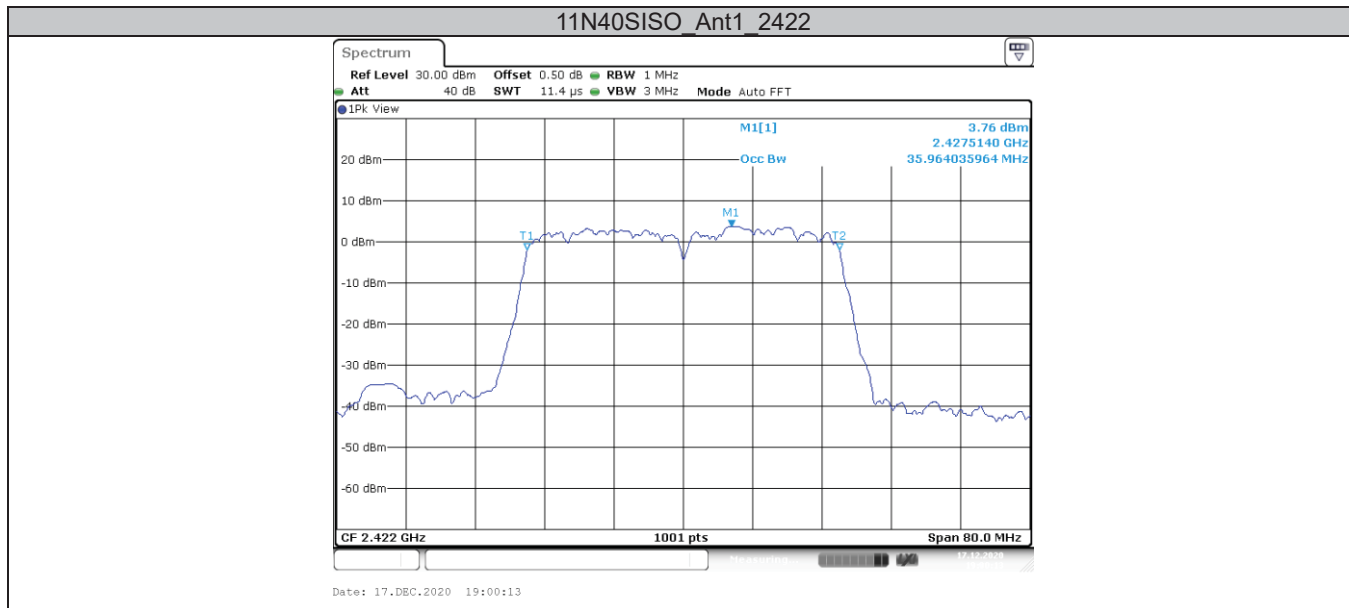

**Appendix B: Maximum power spectral density**

Test Result

| TestMode | Antenna | Channel | Result[dBm/3-100kHz] | Limit[dBm/3kHz] | Verdict |
|-----------|---------|---------|----------------------|-----------------|---------|
| 11B | Ant1 | 2412 | -8.37 | <=8 | PASS |
| | | 2437 | -10.69 | <=8 | PASS |
| | | 2462 | -9.79 | <=8 | PASS |
| 11G | Ant1 | 2412 | -14.26 | <=8 | PASS |
| | | 2437 | -13.43 | <=8 | PASS |
| | | 2462 | -13.78 | <=8 | PASS |
| 11N20SISO | Ant1 | 2412 | -13.88 | <=8 | PASS |
| | | 2437 | -14.85 | <=8 | PASS |
| | | 2462 | -13.61 | <=8 | PASS |
| 11N40SISO | Ant1 | 2422 | -17.9 | <=8 | PASS |
| | | 2437 | -18.46 | <=8 | PASS |
| | | 2452 | -18.55 | <=8 | PASS |



Test Graphs

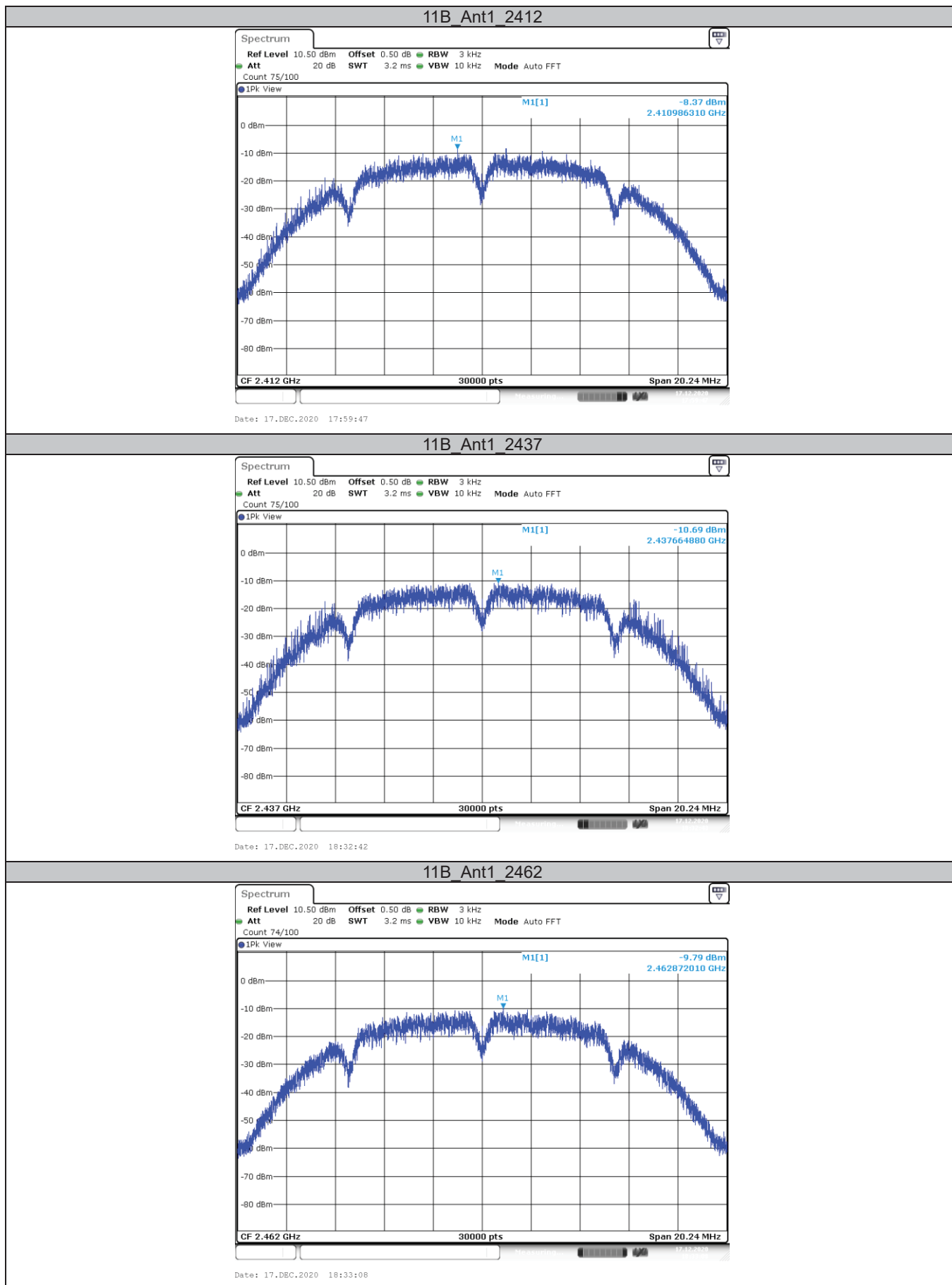

CTC Laboratories, Inc.

1-2/F., Building 2, Jiaquan Building, Guanlan High-Tech Park, Shenzhen, Guangdong, China
 Tel.: (86)755-27521059 Fax: (86)755-27521011 Http://www.sz-ctc.org.cn



For anti-fake verification, please visit the official website of Certification and Accreditation Administration of the People's Republic of China : yz.cnca.cn

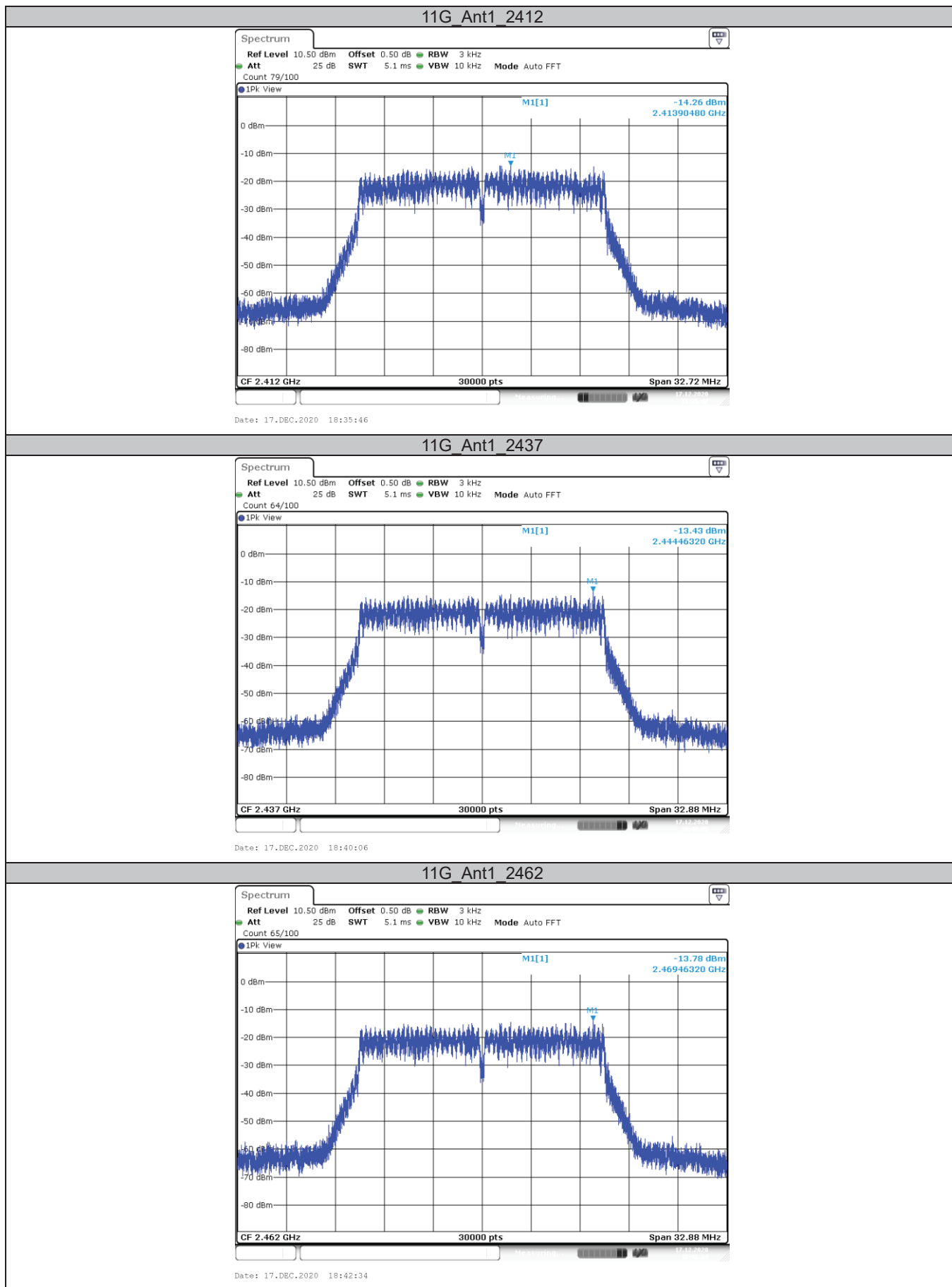

CTC Laboratories, Inc.

1-2/F., Building 2, Jiaquan Building, Guanlan High-Tech Park, Shenzhen, Guangdong, China
 Tel.: (86)755-27521059

Fax: (86)755-27521011 Http://www.sz-ctc.org.cn



For anti-fake verification, please visit the official website of Certification and Accreditation Administration of the People's Republic of China : yz.cnca.cn

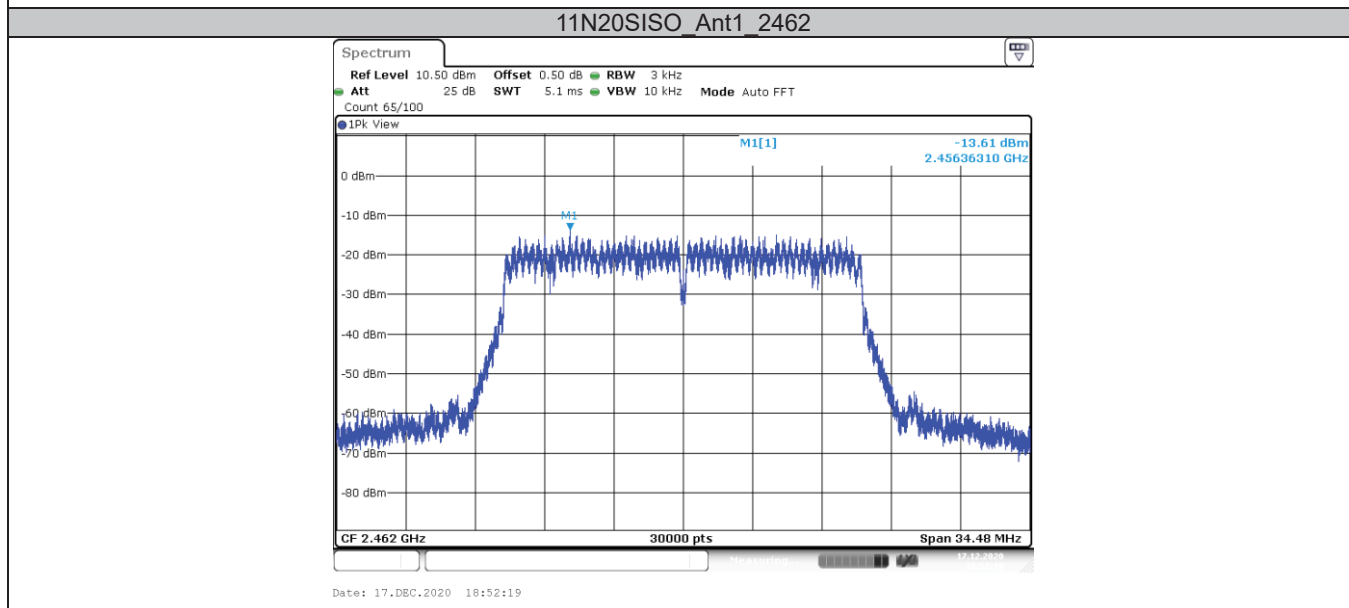
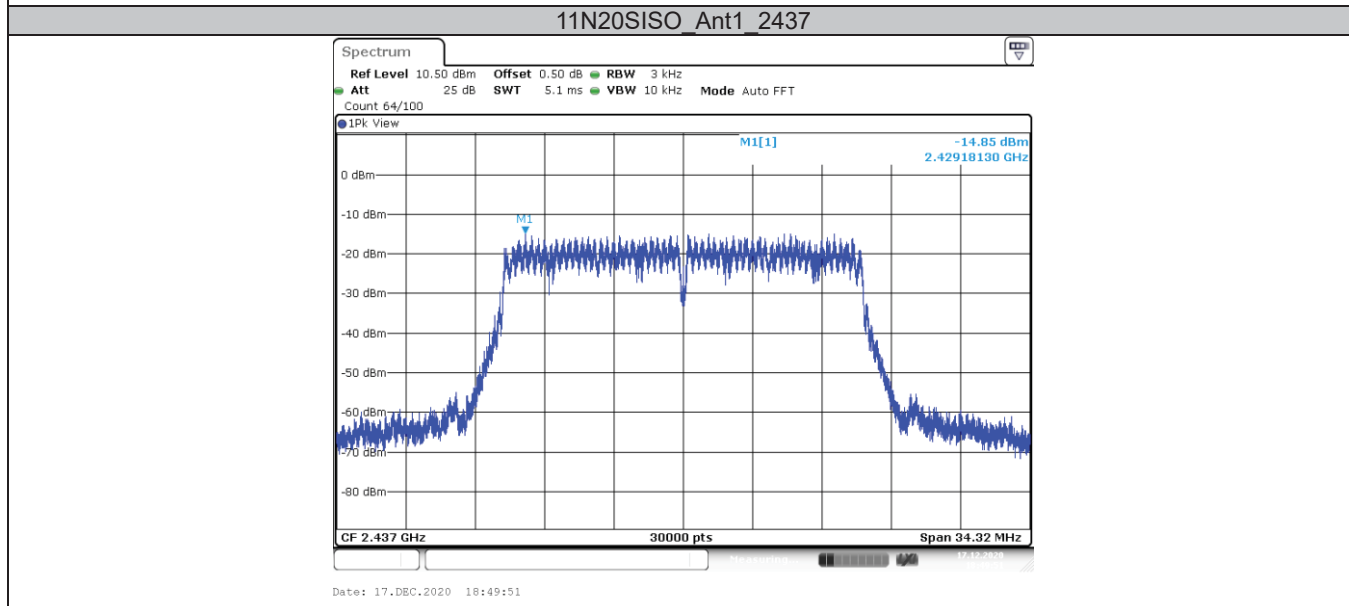
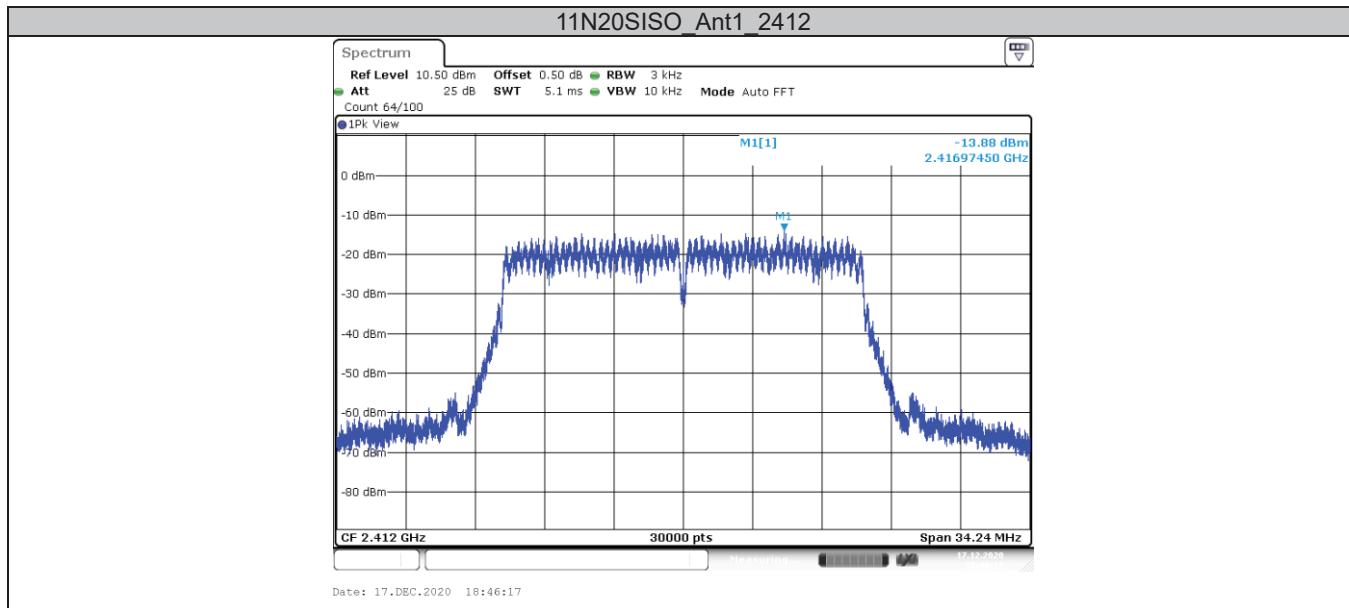

CTC Laboratories, Inc.

1-2/F., Building 2, Jiaquan Building, Guanlan High-Tech Park, Shenzhen, Guangdong, China
 Tel.: (86)755-27521059 Fax: (86)755-27521011 Http://www.sz-ctc.org.cn



For anti-fake verification, please visit the official website of Certification and Accreditation Administration of the People's Republic of China : yz.cnca.cn

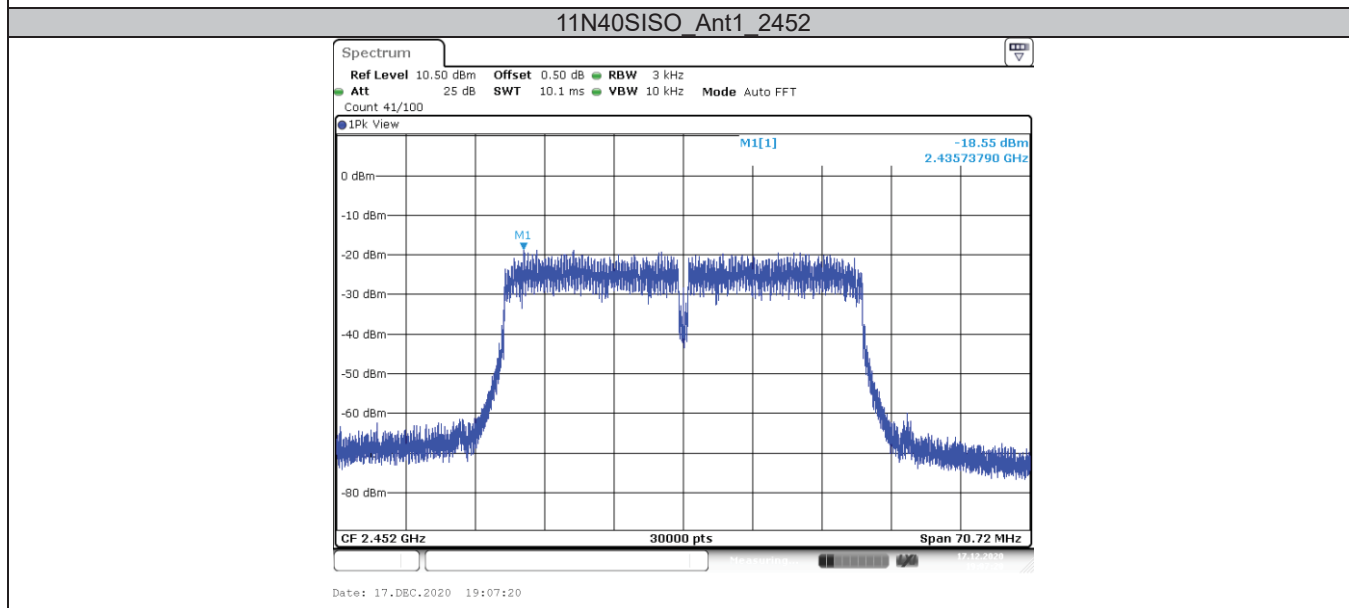
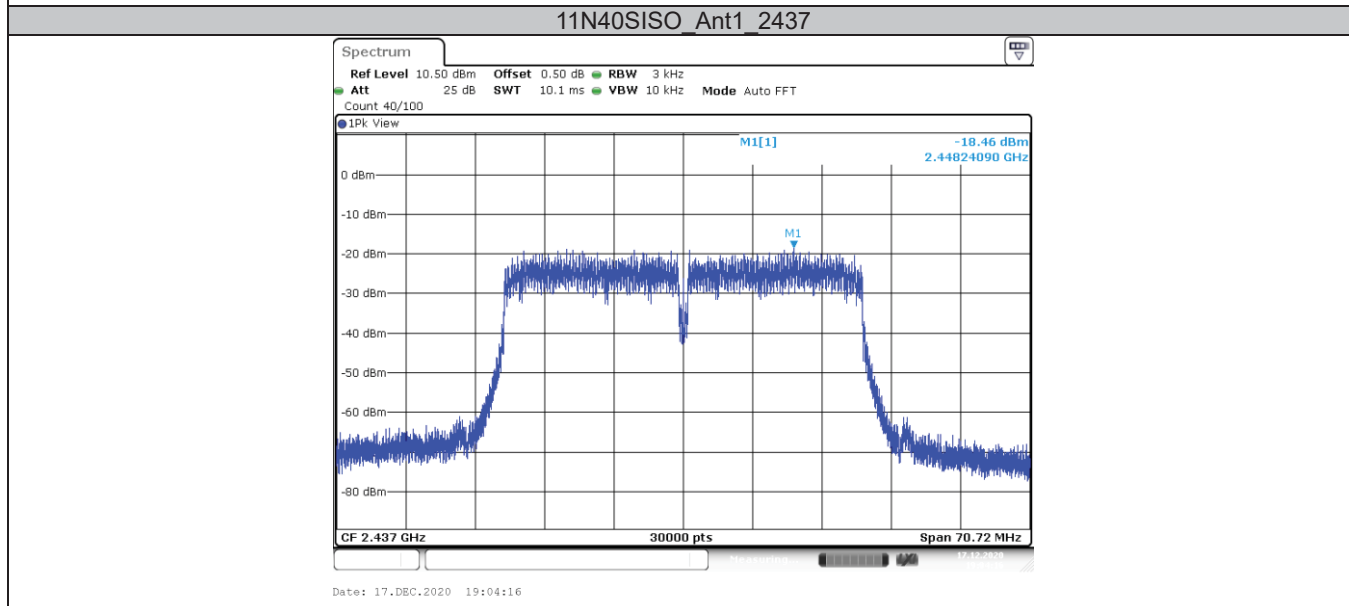
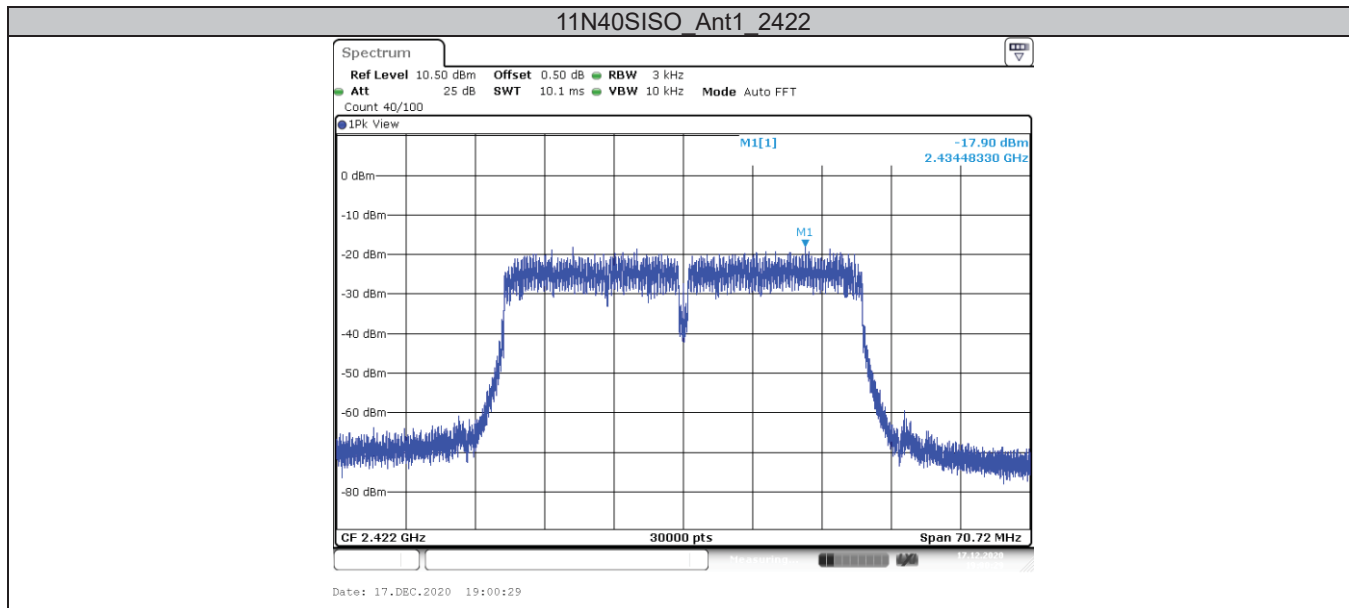

*****THE END*****

CTC Laboratories, Inc.

1-2/F., Building 2, Jiaquan Building, Guanlan High-Tech Park, Shenzhen, Guangdong, China
Tel.: (86)755-27521059 Fax: (86)755-27521011 Http://www.sz-ctc.org.cn



For anti-fake verification, please visit the official website of Certification and Accreditation Administration of the People's Republic of China : yz.cnca.cn