

RF MEASUREMENT REPORT

FCC ID : 2AXJ4T4UV5

APPLICANT : TP-Link Corporation Limited

Application Type : Certification

Product : AC1300 High Gain Wireless Dual Band USB Adapter

Model No. : Archer T4U

Brand Name : tp-link

FCC Classification : Unlicensed National Information Infrastructure (UNII)

FCC Rule Part(s) : Part 15 Subpart E (Section 15.407)

Test Procedure(s) : ANSI C63.10-2013

Received Date : November 18 ,2022

Test Date : November 22, 2022 ~ January 9, 2023

Tested By : Peter Syu
(Peter Syu)

Reviewed By : Paddy Chen
(Paddy Chen)

Approved By : Chenz Ker
(Chenz Ker)



The test results only relate to the tested samples.

This equipment has been shown to be capable of compliance with the applicable technical standards as indicated in the measurement report and was tested in accordance with the measurement procedures specified in ANSI C63.10. Test results reported herein relate only to the item(s) tested.

The test report shall not be reproduced except in full without the written approval of MRT Technology (Taiwan) Co., Ltd.

Revision History

Report No.	Version	Description	Issue Date	Note
2211TW0108-U2	1.0	Original Report	2023-02-10	Valid

CONTENTS

Description	Page
General Information.....	6
1. INTRODUCTION	7
1.1. Scope.....	7
1.2. MRT Test Location.....	7
2. PRODUCT INFORMATION	8
2.1. Equipment Description	8
2.2. Product Specification Subjective to this Report	8
2.3. Operation Frequencies and Channel List	9
2.4. Description of Available Antennas	10
2.5. Test Mode	11
2.6. Configuration of Test System	12
2.7. Test System Details	12
2.8. Description of Test Software	12
2.9. Applied Standards.....	13
2.10. Duty Cycle.....	13
2.11. Test Configuration.....	14
2.12. EMI Suppression Device(s)/Modifications	14
2.13. Labeling Requirements	14
3. DESCRIPTION OF TEST	15
3.1. Evaluation Procedure.....	15
3.2. AC Line Conducted Emissions	15
3.3. Radiated Emissions.....	16
4. ANTENNA REQUIREMENTS.....	17
5. TEST EQUIPMENT CALIBRATION DATE.....	18
6. MEASUREMENT UNCERTAINTY.....	19
7. TEST RESULT	20
7.1. Summary.....	20
7.2. 26dB Bandwidth Measurement	21
7.2.1. Test Limit.....	21
7.2.2. Test Procedure used	21
7.2.3. Test Setting	21
7.2.4. Test Setup	22

7.2.5.	Test Result	23
7.3.	6dB Bandwidth Measurement	32
7.3.1.	Test Limit	32
7.3.2.	Test Procedure used	32
7.3.3.	Test Setting	32
7.3.4.	Test Setup	32
7.3.5.	Test Result	33
7.4.	Output Power Measurement.....	36
7.4.1.	Test Limit	36
7.4.2.	Test Procedure Used.....	36
7.4.3.	Test Setting	36
7.4.4.	Test Setup	37
7.4.5.	Test Result	38
7.5.	Transmit Power Control.....	41
7.5.1.	Test Limit	41
7.5.2.	Test Procedure Used.....	41
7.5.3.	Test Setting	41
7.5.4.	Test Setup	41
7.5.5.	Test Result	41
7.6.	Power Spectral Density Measurement.....	42
7.6.1.	Test Limit	42
7.6.2.	Test Procedure Used.....	42
7.6.3.	Test Setting	42
7.6.4.	Test Setup	43
7.6.5.	Test Result	44
7.7.	Frequency Stability Measurement	59
7.7.1.	Test Limit	59
7.7.2.	Test Limit	59
7.7.3.	Test Setup	60
7.7.4.	Test Result	60
7.8.	Radiated Spurious Emission Measurement	61
7.8.1.	Test Limit	61
7.8.2.	Test Procedure Used.....	61
7.8.3.	Test Setting	61
7.8.4.	Test Setup	63
7.8.5.	Test Result	65
7.9.	Radiated Restricted Band Edge Measurement.....	153
7.9.1.	Test Limit.....	153

7.9.2. Test Procedure Used.....	155
7.9.3. Test Setting	155
7.9.4. Test Setup	156
7.9.5. Test Result	157
7.10. AC Conducted Emissions Measurement	226
7.10.1. Test Limit.....	226
7.10.2. Test Setup	226
7.10.3. Test Result	227
8. CONCLUSION	231
Appendix A : Test Setup Photograph	232
Appendix B : External Photograph.....	233
Appendix C : Internal Photograph.....	234

General Information

Applicant	TP-Link Corporation Limited
Applicant Address	Room 901, 9/F., New East Ocean Centre, 9 Science Museum Road, Tsim Sha Tsui, Kowloon, Hongkong
Manufacturer	TP-Link Corporation Limited
Manufacturer Address	Room 901, 9/F., New East Ocean Centre, 9 Science Museum Road, Tsim Sha Tsui, Kowloon, Hongkong
Test Site	MRT Technology (Taiwan) Co., Ltd
Test Site Address	No. 38, Fuxing Second Rd., Guishan Dist., Taoyuan City 333, Taiwan (R.O.C)
MRT FCC Registration No.	291082
FCC Rule Part(s)	Part 15.407

Test Facility / Accreditations

1. MRT facility is a FCC registered (Reg. No. 291082) test facility with the site description report on file and is designated by the FCC as an Accredited Test Firm.
2. MRT facility is an IC registered (MRT Reg. No. 21723) test laboratory with the site description on file at Industry Canada.
3. MRT Lab is accredited to ISO 17025 by the Taiwan Accreditation Foundation (TAF Cert. No. 3261) in EMC, Telecommunications and Radio testing for FCC (Designation Number: TW3261), Industry Taiwan, EU and TELEC Rules.

1. INTRODUCTION

1.1. Scope

Measurement and determination of electromagnetic emissions (EMC) of radio frequency devices including intentional and/or unintentional radiators for compliance with the technical rules and regulations of the Federal Communications Commission and the Industry Canada Certification and Engineering Bureau.

1.2. MRT Test Location

The map below shows the location of the MRT LABORATORY, its proximity to the Taoyuan City. These measurement tests were conducted at the MRT Technology (Taiwan) Co., Ltd. Facility located at No.38, Fuxing 2nd Rd., Guishan Dist., Taoyuan City 33377, Taiwan (R.O.C).

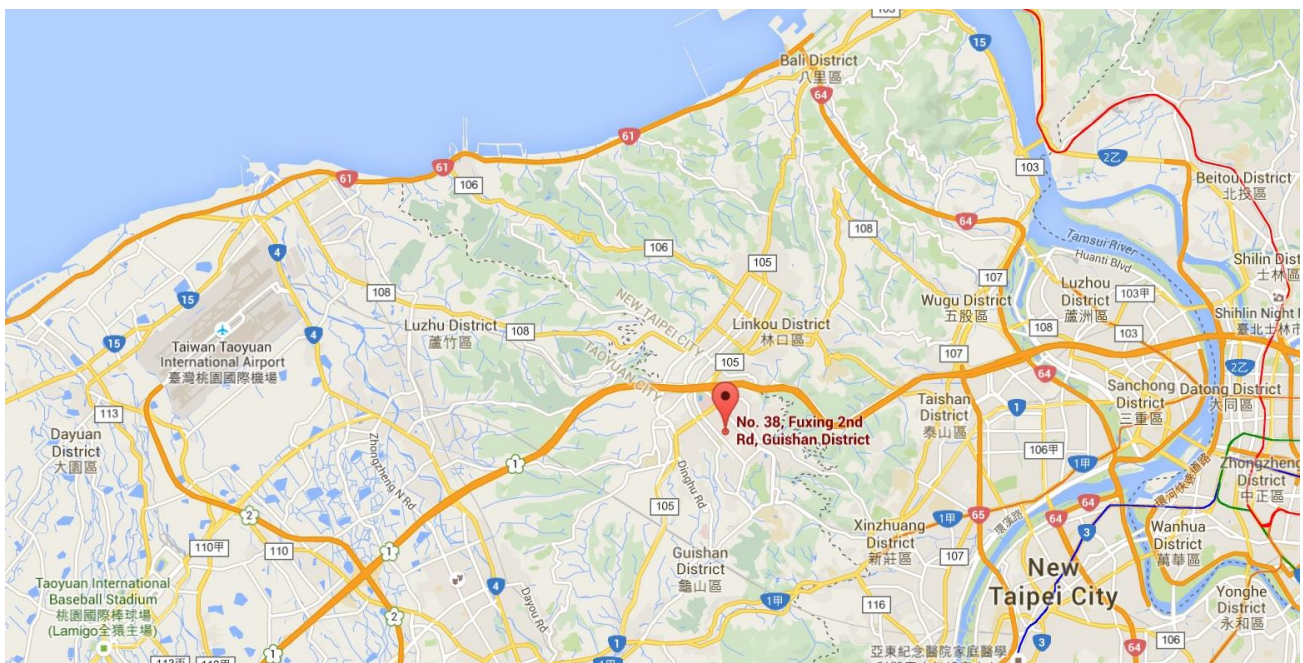

2. PRODUCT INFORMATION

2.1. Equipment Description

Product Name:	AC1300 High Gain Wireless Dual Band USB Adapter
Model No.:	Archer T4U
Brand Name:	tp-link
Wi-Fi Specification:	802.11a/b/g/n/ac
EUT Identification No.:	#1-1 (Conducted) #1-2 (Radiated)

2.2. Product Specification Subjective to this Report

Frequency Range:	For 802.11a/n-HT20/ac-VHT20: 5180~5240MHz, 5260~5320MHz, 5500~5720MHz, 5745~5825MHz For 802.11n-HT40/ac-VHT40: 5190~5230MHz, 5270~5310MHz, 5510~5710MHz, 5755~5795MHz For 802.11ac-VHT80: 5210MHz, 5290MHz, 5530MHz, 5610 MHz, 5690MHz, 5775MHz
Type of Modulation:	802.11a/n/ac: OFDM
Data Rate:	802.11a: 6/9/12/18/24/36/48/54Mbps 802.11n: up to 300Mbps 802.11ac: up to 866.7Mbps

2.3. Operation Frequencies and Channel List

802.11 n-HT20/ ac-VHT20

Channel	Frequency	Channel	Frequency	Channel	Frequency
36	5180 MHz	40	5200 MHz	44	5220 MHz
48	5240 MHz	52	5260 MHz	56	5280 MHz
60	5300 MHz	64	5320 MHz	100	5500 MHz
104	5520 MHz	108	5540 MHz	112	5560 MHz
116	5580 MHz	120	5600 MHz	124	5620 MHz
128	5640 MHz	132	5660 MHz	136	5680 MHz
140	5700 MHz	144	5720 MHz	149	5745 MHz
153	5765 MHz	157	5785 MHz	161	5805 MHz
165	5825 MHz	--	--	--	--

802.11 n-HT40/ ac-VHT40

Channel	Frequency	Channel	Frequency	Channel	Frequency
38	5190 MHz	46	5230 MHz	54	5270 MHz
62	5310 MHz	102	5510 MHz	110	5550 MHz
118	5590 MHz	126	5630 MHz	134	5670 MHz
142	5710 MHz	151	5755 MHz	159	5795 MHz

802.11ac-VHT80

Channel	Frequency	Channel	Frequency	Channel	Frequency
42	5210 MHz	58	5290 MHz	106	5530 MHz
122	5610 MHz	138	5690 MHz	155	5775 MHz

2.4. Description of Available Antennas

Antenna Type	Frequency Band (MHz)	Mode	Tx Path	Antenna Gain (dBi)	CDD Directional Gain (dBi)	
					For Power	For PSD
Dipole	2.400 ~ 2483.5	802.11b/g	1	2.00	--	--
	2.400 ~ 2483.5	802.11n	2	2.00	2.00	5.01
	5150 ~ 5250	802.11a	1	2.47	--	--
	5250 ~ 5350	802.11a	1	2.62	--	--
	5470 ~ 5725	802.11a	1	2.75	--	--
	5725 ~ 5850	802.11a	1	3.00	--	--
	5150 ~ 5250	802.11n/ac	2	2.47	2.47	5.48
	5250 ~ 5350	802.11n/ac	2	2.62	2.62	5.63
	5470 ~ 5725	802.11n/ac	2	2.75	2.75	5.76
	5725 ~ 5850	802.11n/ac	2	3.00	3.00	6.01

Note: The EUT supports SISO Mode for 802.11a/b/g and Cyclic Delay Diversity (CDD) mode for 802.11n/ac.

For CDD transmissions, directional gain is calculated as follows, $N_{ANT} = 2$, $N_{SS} = 1$.

If all antennas have the same gain, G_{ANT} , Directional gain = $G_{ANT} + \text{Array Gain}$, where Array Gain is as follows.

- For power spectral density (PSD) measurements on all devices,
 Array Gain = $10 \log (N_{ANT} / N_{SS}) \text{ dB} = 3.01$;
- For power measurements on IEEE 802.11 devices,
 Array Gain = 0 dB for $N_{ANT} \leq 4$;

Test Mode	Tx Paths	SISO Mode	CDD Mode
802.11b/g	1	√	X
802.11n	2	X	√
802.11a	1	√	X
802.11n/ac	2	X	√

2.5. Test Mode

Mode 1: Transmit by 802.11a (6Mbps) - Ant 0 – SISO Mode
Mode 2: Transmit by 802.11ac-VHT20 _ Nss = 1 (MCS0) - CDD Mode
Mode 3: Transmit by 802.11ac-VHT20 _ Nss = 1 (MCS0) – CDD Mode
Mode 4: Transmit by 802.11ac-VHT40 _ Nss = 1 (MCS0) – CDD Mode
Note: <ol style="list-style-type: none">1. For Radiated emission, the modulation and the data rate picked for testing are determined by the Max. RF conducted power.2. For CDD mode, this device supports 2 N_{SS} and power level is the same of spatial multiplexing. The worst case is N_{SS}=1.3. As Designated by manufacturer, the lowest data rate was the worst condition, so all the tests were done with lowest data rate.4. Due to the same modulation between 802.11n, so 802.11n-HT20 and HT40 are covered by 802.11ac-VHT20 and VHT40 in this report, meanwhile, power setting for 802.11n-HT20 and HT40 will not be greater than 802.11ac-VHT20 and VHT40.

2.6. Configuration of Test System

The device was tested per the guidance ANSI C63.10: 2013 was used to reference the appropriate EUT setup for radiated emissions testing and AC line conducted testing.

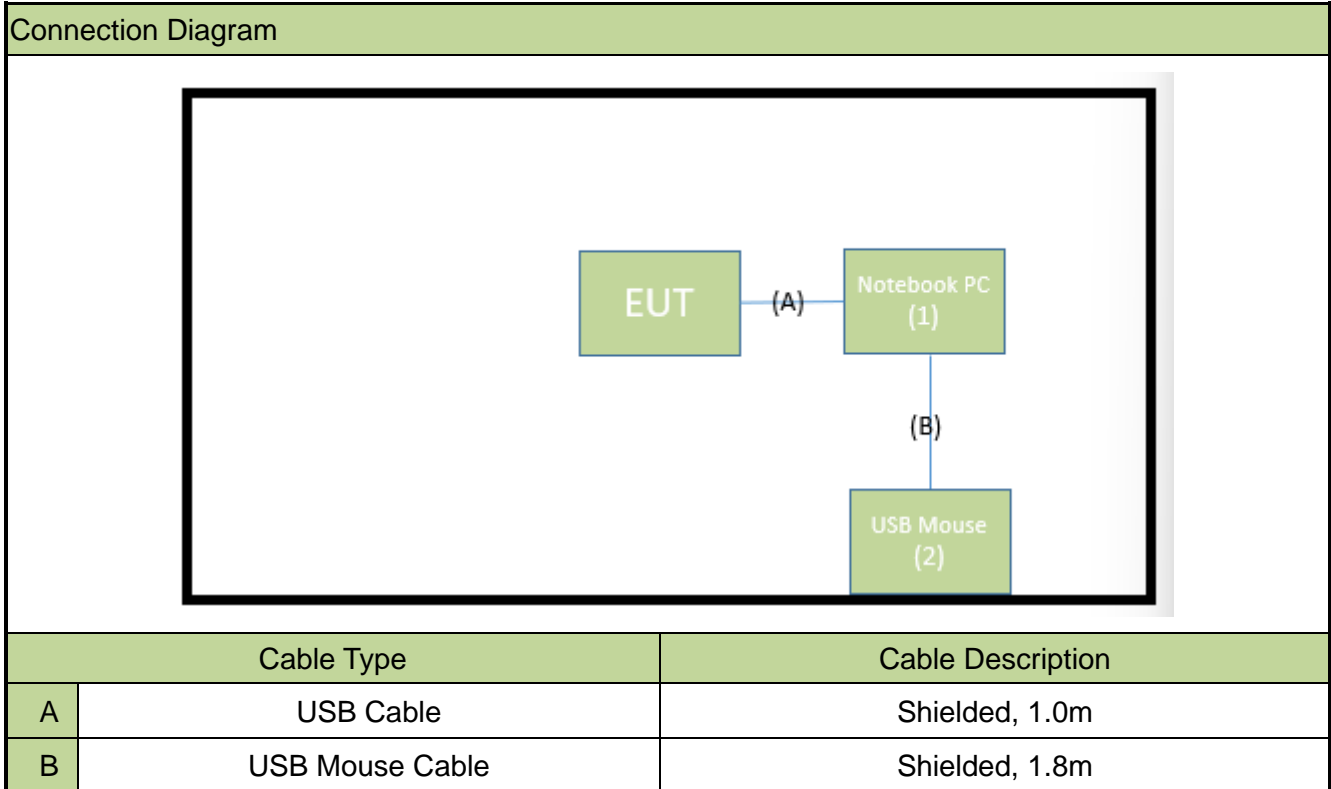

2.7. Test System Details

The types for all equipments, plus descriptions of all cables used in the tested system (including inserted cards) are:

	Product	Manufacturer	Model No.	Serial No.	Power Cord
1	Notebook	Lenovo	T450	N/A	Shielded, 0.8m
2	USB Mouse	Logitech	M90	N/A	N/A

2.8. Description of Test Software

The test utility software used during testing was “Realtek 11ac 8812A USB WLAN MP Tool v0.0000.03”.

Note: Final power setting please refer to operational description.

2.9. Applied Standards

According to the specifications of the manufacturer, the EUT must comply with the requirements of the following standards:

- FCC Part 15.247
- KDB 789033 D02v02r01,
- KDB 662911 D01v02r01
- ANSI C63.10-2013

2.10. Duty Cycle

5GHz (NII) operation is possible in 20MHz, 40MHz and 80MHz channel bandwidths. The maximum achievable duty cycles for all modes were determined based on measurements performed on a spectrum analyzer in zero-span mode with RBW = 8MHz, VBW = 50MHz. The RBW and VBW were both greater than 50/T, where T is the minimum transmission duration, and the number of sweep points across T was greater than 100. The duty cycles are as follows:

Test Mode	Duty Cycle
802.11a	97.39%
802.11ac-VHT20	96.97%
802.11ac-VHT40	88.96%
802.11ac-VHT80	76.71%

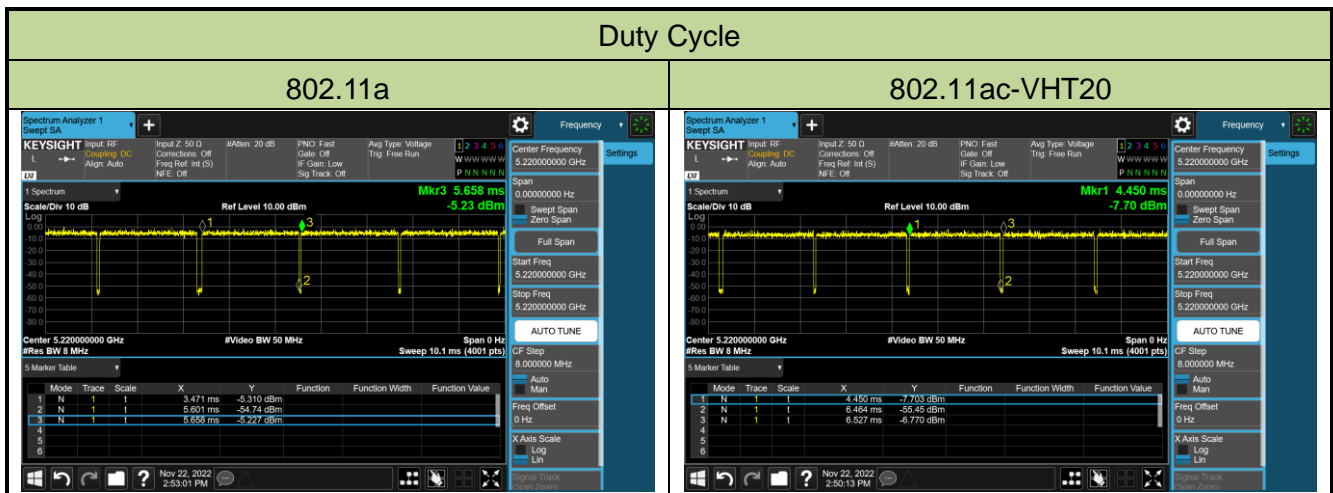

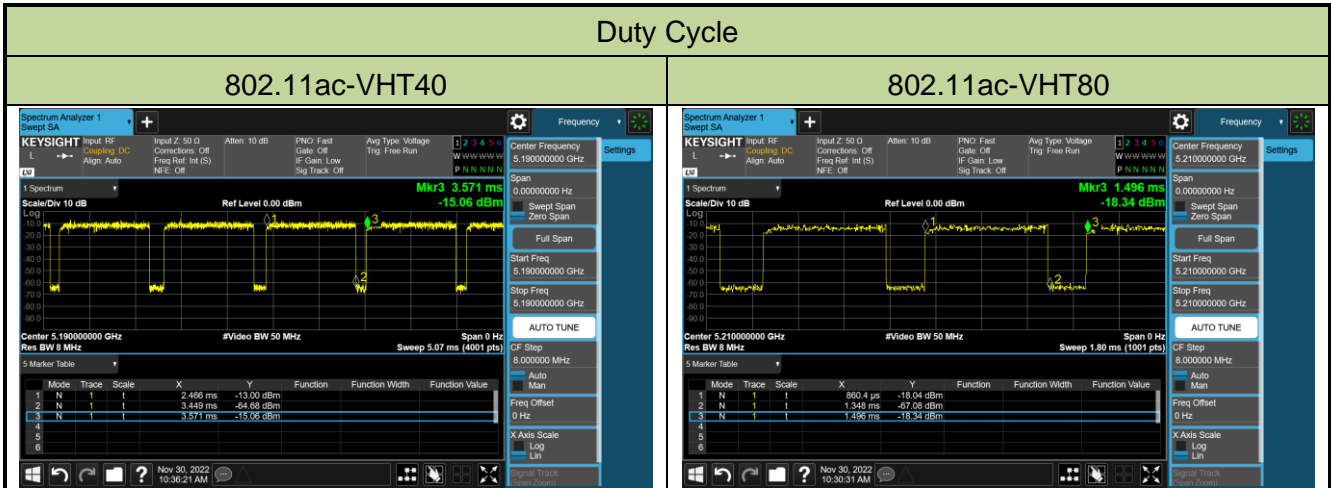

2.11. Test Configuration

This device was tested per the guidance of KDB 789033 D02v02r01. ANSI C63.10-2013 was used to reference the appropriate EUT setup for radiated spurious emissions testing and AC line conducted testing.

2.12. EMI Suppression Device(s)/Modifications

No EMI suppression device(s) were added and/or no modifications were made during testing.

2.13. Labeling Requirements

Per 2.1074 & 15.19; Docket 95-19

The label shall be permanently affixed at a conspicuous location on the device; instruction manual or pamphlet supplied to the user and be readily visible to the purchaser at the time of purchase. However, when the device is so small wherein placement of the label with specified statement is not practical, only the FCC ID must be displayed on the device per Section 15.19(a)(5). Please see attachment for FCC ID label and label location.

3. DESCRIPTION OF TEST

3.1. Evaluation Procedure

The measurement procedures described in the American National Standard of Procedures for Compliance Testing of Unlicensed Wireless Devices (ANSI C63.10-2013), and the guidance provided in KDB 789033 D02v02r01 were used in the measurement.

3.2. AC Line Conducted Emissions

The line-conducted facility is located inside an 9'x4'x3' shielded enclosure. A 1m x 2m wooden table 80cm high is placed 40cm away from the vertical wall and 80cm away from the sidewall of the shielded room. Two 10kHz-30MHz, 50Ω/50uH Line-Impedance Stabilization Networks (LISNs) are bonded to the shielded room floor. Power to the LISNs is filtered by external high-current high-insertion loss power line filters. These filters attenuate ambient signal noise from entering the measurement lines. These filters are also bonded to the shielded enclosure.

The EUT is powered from one LISN and the support equipment is powered from the second LISN. All interconnecting cables more than 1 meter were shortened to a 1 meter length by non-inductive bundling (serpentine fashion) and draped over the back edge of the test table. All cables were at least 40cm above the horizontal reference ground-plane. Power cables for support equipment were routed down to the second LISN while ensuring that that cables were not draped over the second LISN.

Sufficient time for the EUT, support equipment, and test equipment was allowed in order for them to warm up to their normal operating condition. The RF output of the LISN was connected to the receiver and exploratory measurements were made to determine the frequencies producing the maximum emission from the EUT. The receiver was scanned from 150kHz to 30MHz. The detector function was set to peak mode for exploratory measurements while the bandwidth of the analyzer was set to 9kHz. The EUT, support equipment, and interconnecting cables were arranged and manipulated to maximize each emission. Each emission was also maximized by varying: power lines, the mode of operation or data exchange speed, or support equipment whichever determined the worst-case emission. Once the worst case emissions have been identified, the one EUT cable configuration/arrangement and mode of operation that produced these emissions are used for final measurements on the same test site. The analyzer is set to CISPR quasi-peak and average detectors with a 9kHz resolution bandwidth for final measurements.

An extension cord was used to connect to a single LISN which powered by EUT. The extension cord was calibrated with LISN, the impedance and insertion loss are compliance with the requirements as stated in ANSI C63.10-2013.

3.3. Radiated Emissions

The radiated test facilities consisted of an indoor 3 meter semi-anechoic chamber used for final measurements and exploratory measurements, when necessary. The measurement area is contained within the semi-anechoic chamber which is shielded from any ambient interference. For measurements above 1GHz absorbers are arranged on the floor between the turn table and the antenna mast in such a way so as to maximize the reduction of reflections. For measurements below 1GHz, the absorbers are removed. A turntable is used for radiated measurement. It is a continuously rotatable, remote controlled, metallic turntable and 2 meters (6.56 ft.) in diameter. The turn table is flush with the raised floor of the chamber in order to maintain its function as a ground plane. An 80cm high PVC support structure is placed on top of the turntable.

For all measurements, the spectrum was scanned through all EUT azimuths and from 1 to 4 meter receive antenna height using a broadband antenna from 30MHz up to the upper frequency shown in 15.33(b)(1) depending on the highest frequency generated or used in the device or on which the device operates or tunes. For frequencies above 1GHz, linearly polarized double ridge horn antennas were used. For frequencies below 30MHz, a calibrated loop antenna was used. When exploratory measurements were necessary, they were performed at 1 meter test distance inside the semi-anechoic chamber using broadband antennas, broadband amplifiers, and spectrum analyzers to determine the frequencies and modes producing the maximum emissions. Sufficient time for the EUT, support equipment, and test equipment was allowed in order for them to warm up to their normal operating condition. The test set-up for frequencies below 1GHz was placed on top of the 0.8 meter high, 1 x 1.5 meter table; and test set-up for frequencies 1-40GHz was placed on top of the 1.5 meter high, 1 x 1.5 meter table. The EUT, support equipment, and interconnecting cables were arranged and manipulated to maximize each emission. Appropriate precaution was taken to ensure that all emissions from the EUT were maximized and investigated. The system configuration, clock speed, mode of operation or video resolution, if applicable, turntable azimuth, and receive antenna height was noted for each frequency found.

Final measurements were made in the semi-anechoic chamber using calibrated, linearly polarized broadband and horn antennas. The test setup was configured to the setup that produced the worst case emissions. The spectrum analyzer was set to investigate all frequencies required for testing to compare the highest radiated disturbances with respect to the specified limits. The turntable containing the EUT was rotated through 360 degrees and the height of the receive antenna was varied 1 to 4 meters and stopped at the azimuth and height producing the maximum emission. Each emission was maximized by changing the orientation of the EUT through three orthogonal planes and changing the polarity of the receive antenna, whichever produced the worst-case emissions. According to 3dB Beam-Width of horn antenna, the horn antenna should be always directed to the EUT when rising height.

4. ANTENNA REQUIREMENTS

Excerpt from §15.203 of the FCC Rules/Regulations:

“An intentional radiator antenna shall be designed to ensure that no antenna other than that furnished by the responsible party can be used with the device. The use of a permanently attached antenna or of an antenna that uses a unique coupling to the intentional radiator shall be considered sufficient to comply with the provisions of this section.”

- The antenna of the device is permanently attached.
- There are no provisions for connection to an external antenna.

Conclusion:

The EUT unit complies with the requirement of §15.203.

5. TEST EQUIPMENT CALIBRATION DATE

Conducted Emissions

Instrument	Manufacturer	Type No.	Asset No.	Cali. Interval	Cali. Due Date
Two-Line V-Network	R&S	ENV216	MRTTWA00019	1 year	2023/3/7
Cable	Rosnol	N1C50-RG400-B 1C50-500CM	MRTTWE00013	1 year	2023/6/19
EMI Test Receiver	R&S	ESR3	MRTTWA00009	1 year	2023/3/9

Radiated Emissions

Instrument	Manufacturer	Type No.	Asset No.	Cali. Interval	Cali. Due Date
Broadband TRILOG Antenna	SCHWARZBECK	VULB 9162	MRTTWA00001	1 year	2023/12/21
EMI Test Receiver	R&S	ESR3	MRTTWA00009	1 year	2023/3/9
Signal Analyzer	R&S	FSVA3044	MRTTWA00092	1 year	2023/6/23
Active Loop Antenna	Schwarzbeck	FMZB 1519B	MRTTWA00002	1 year	2023/5/24
Broadband Hornantenna	RFSPIN	DRH18-E	MRTTWA00087	1 year	2023/5/10
Breitband Hornantenna	Schwarzbeck	BBHA 9170	MRTTWA00004	1 year	2023/3/29
Broadband Preampfier	EMC Instruments corporation	EMC118A45SE	MRTTWA00088	1 year	2023/5/9
Broadband Preampfier	SCHWARZBECK	BBV 9718	MRTTWA00005	1 year	2023/3/30
Cable	HUBERSUHNER	SF106	MRTTWE00034	1 year	2023/6/27

Conducted Test Equipment – SR6

Instrument	Manufacturer	Type No.	Asset No.	Cali. Interval	Cali. Due Date
EXA Signal Analyzer	KEYSIGHT	N9010A	MRTTWA00012	1 year	2023/10/5
EXA Signal Analyzer	KEYSIGHT	N9010B	MRTTWA00074	1 year	2023/7/19
USB Wideband Power Sensor	KEYSIGHT	U2021XA	MRTTWA00015	1 year	2023/3/16

Test Software

Software	Version	Function
e3	9.160520a	EMI Test Software

6. MEASUREMENT UNCERTAINTY

Where relevant, the following test uncertainty levels have been estimated for tests performed on the EUT as specified in CISPR 16-4-2. This uncertainty represents an expanded uncertainty expressed at approximately the 95% confidence level using a coverage factor of $k = 2$.

AC Conducted Emission Measurement
Measuring Uncertainty for a Level of Confidence of 95% ($U=2Uc(y)$): 150kHz~30MHz: $\pm 2.53\text{dB}$
Radiated Emission Measurement
Measuring Uncertainty for a Level of Confidence of 95% ($U=2Uc(y)$): 9kHz ~ 1GHz: $\pm 4.25\text{dB}$ 1GHz ~ 40GHz: $\pm 4.45\text{dB}$
Conducted Power (Carrier Power / Power Density)
Measuring Uncertainty for a Level of Confidence of 95% ($U=2Uc(y)$): $\pm 0.84\text{dB}$
Conducted Spurious Emission
Measuring Uncertainty for a Level of Confidence of 95% ($U=2Uc(y)$): $\pm 2.65\text{ dB}$
Occupied Bandwidth
Measuring Uncertainty for a Level of Confidence of 95% ($U=2Uc(y)$): $\pm 3.3\%$
Temp. / Humidity
Measuring Uncertainty for a Level of Confidence of 95% ($U=2Uc(y)$): $\pm 0.82^\circ\text{C}/ \pm 3\%$
Frequency Error
Measuring Uncertainty for a Level of Confidence of 95% ($U=2Uc(y)$): $\pm 78.4\text{Hz}$

7. TEST RESULT

7.1. Summary

FCC Section(s)	Test Description	Test Limit	Test Condition	Test Result	Reference
15.407(a)	26dB Bandwidth	N/A	Conducted	Pass	Section 7.2
15.407(e)	6dB Bandwidth	$\geq 500\text{kHz}$		Pass	Section 7.3
15.407(a)(1)(iv), (2), (3)(i)	Maximum Conducted Output Power	Refer to section 7.4		Pass	Section 7.4
15.407(h)(1)	Transmit Power Control	$\leq 24 \text{ dBm}$		N/A	Section 7.5
15.407(a)(1)(iv), (2), (3)(i), (12)	Peak Power Spectral Density	Refer to section 7.6		Pass	Section 7.6
15.407(g)	Frequency Stability	N/A		Pass	Section 7.7
15.407(b)(1), (2), (3), (4)(i)	Undesirable Emissions	Refer to Section 7.8	Radiated	Pass	Section 7.8 & 7.9
15.205, 15.209 15.407(b)(8), (9), (10)	General Field Strength Limits (Restricted Bands and Radiated Emission Limits)	Emissions in restricted bands must meet the radiated limits detailed in 15.209		Pass	
15.207	AC Conducted Emissions 150kHz - 30MHz	< FCC 15.207 limits	Line Conducted	Pass	Section 7.10

Notes:

- 1) Determining compliance is based on the test results met the regulation limits or requirements declared by clients, and the test results don't take into account the value of measurement uncertainty.
- 2) The analyzer plots shown in this section were all taken with a correction table loaded into the analyzer. The correction table was used to account for the losses of the cables and attenuators used as part of the system to connect the EUT to the analyzer at all frequencies of interest.
- 3) For radiated emission test, every axis (X, Y, Z) was also verified. The test results shown in the following sections represent the worst-case emissions.

7.2. 26dB Bandwidth Measurement

7.2.1. Test Limit

N/A

7.2.2. Test Procedure used

KDB 789033 D02v02r01- Section II)C)1) (26dB Bandwidth)

KDB 789033 D02v02r01- Section II)D) (99% Bandwidth)

7.2.3. Test Setting

26dB Bandwidth

1. The analyzers' automatic bandwidth measurement capability was used to perform the 26dB bandwidth
2. RBW = approximately 1% of the emission bandwidth.
3. VBW > RBW
4. Detector = Peak.
5. Trace mode = max hold.
6. Measure the maximum width of the emission that is 26 dB down from the maximum of the emission. Compare this with the RBW setting of the analyzer. Readjust RBW and repeat measurement as needed until the RBW/EBW ratio is approximately 1%.

99% Bandwidth

1. Set center frequency to the nominal EUT channel center frequency.
2. RBW = 1% to 5% of the OBW
3. VBW $\geq 3 \times$ RBW
4. Span = 1.5 times to 5 times the OBW
5. Detector = peak
6. Trace mode = max hold
7. Allow the trace to stabilize.
8. Use the 99% power bandwidth function of the instrument.

7.2.4. Test Setup

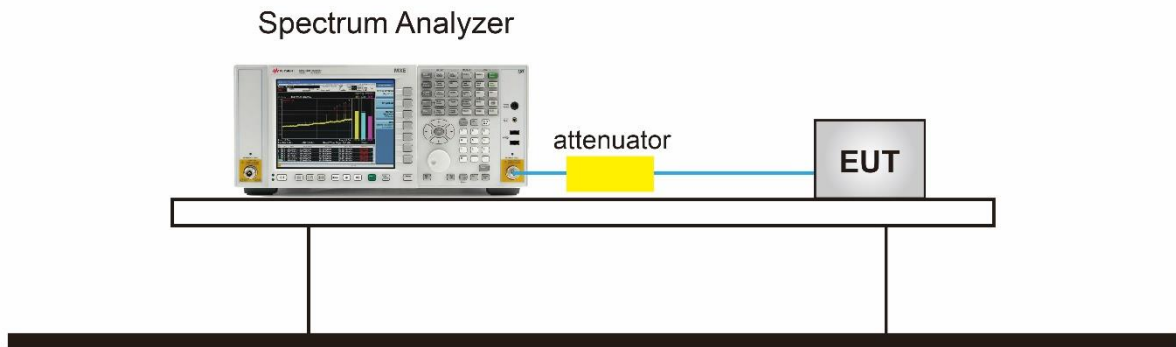

7.2.5. Test Result

Product	AC1300 High Gain Wireless Dual Band USB Adapter	Test Engineer	Marvin
Test Site	SR6	Test Date	2022/11/29~2023/1/6
Test Item	26dB Bandwidth & 99% Bandwidth		

Test Mode	Channel No.	Frequency (MHz)	26dB Bandwidth (MHz)	99% Bandwidth (MHz)
Ant 0				
802.11a	36	5180	20.490	16.578
802.11a	44	5220	20.350	16.564
802.11a	48	5240	20.760	16.523
802.11a	52	5260	20.720	16.580
802.11a	60	5300	20.360	16.559
802.11a	64	5320	20.740	16.567
802.11a	100	5500	20.740	16.578
802.11a	118	5580	20.210	16.600
802.11a	140	5700	20.070	16.544
802.11a	144	5720	20.660	16.607
802.11a	149	5745	20.200	16.594
802.11a	157	5785	20.410	16.589
802.11a	165	5825	20.850	16.554
802.11ac-VHT20	36	5180	21.110	17.711
802.11ac-VHT20	44	5220	20.970	17.674
802.11ac-VHT20	48	5240	21.280	17.698
802.11ac-VHT20	52	5260	21.150	17.702
802.11ac-VHT20	60	5300	21.240	17.710
802.11ac-VHT20	64	5320	21.450	17.698
802.11ac-VHT20	100	5500	21.530	17.688
802.11ac-VHT20	118	5580	20.970	17.703
802.11ac-VHT20	140	5700	20.940	17.703
802.11ac-VHT20	144	5720	21.770	17.731
802.11ac-VHT20	149	5745	22.600	17.750
802.11ac-VHT20	157	5785	21.480	17.808
802.11ac-VHT20	165	5825	20.930	17.717

Test Mode	Channel No.	Frequency (MHz)	26dB Bandwidth (MHz)	99% Bandwidth (MHz)
802.11ac-VHT40	38	5190	42.320	36.286
802.11ac-VHT40	46	5230	41.720	36.293
802.11ac-VHT40	54	5270	42.700	36.325
802.11ac-VHT40	62	5310	42.180	36.321
802.11ac-VHT40	102	5510	42.680	36.324
802.11ac-VHT40	110	5550	42.160	36.295
802.11ac-VHT40	134	5670	62.440	36.367
802.11ac-VHT40	142	5710	44.860	36.298
802.11ac-VHT40	151	5755	56.890	36.412
802.11ac-VHT40	159	5795	42.140	36.350
802.11ac-VHT80	42	5210	79.970	75.315
802.11ac-VHT80	58	5290	80.370	75.169
802.11ac-VHT80	106	5530	79.870	75.094
802.11ac-VHT80	122	5610	79.710	75.318
802.11ac-VHT80	138	5690	82.320	75.402
802.11ac-VHT80	155	5775	81.250	75.239

802.11a 26dB Bandwidth & 99% Bandwidth

Channel 36 (5180MHz)

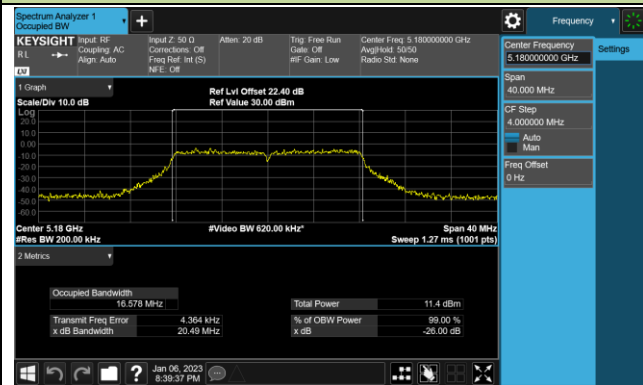

Channel 44 (5220MHz)

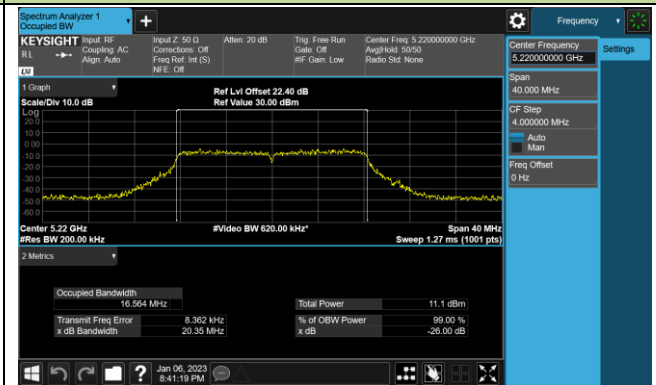

Channel 48 (5240MHz)

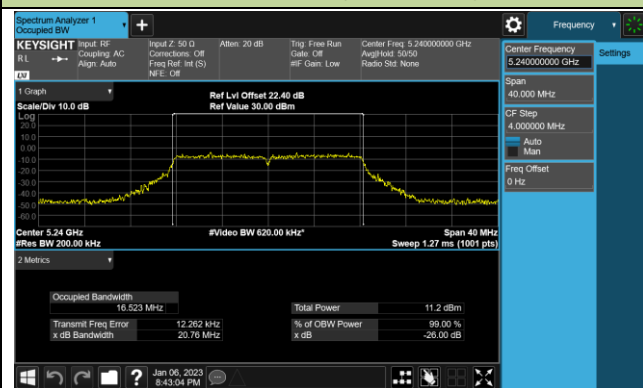

Channel 52 (5260MHz)

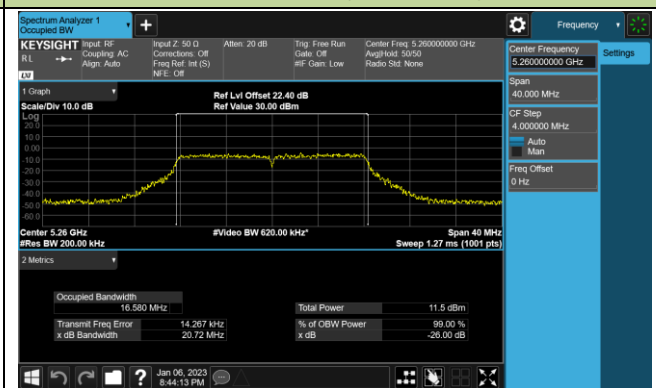

Channel 60 (5300MHz)

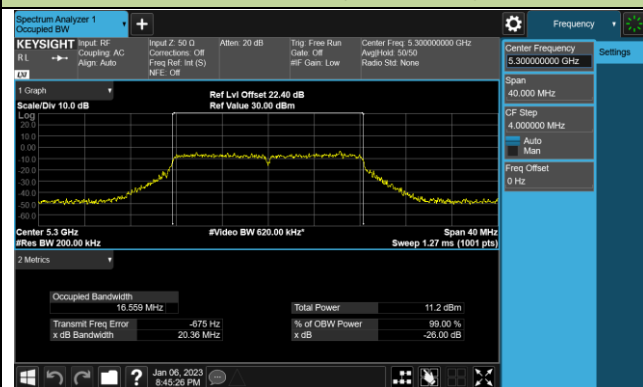

Channel 64 (5320MHz)

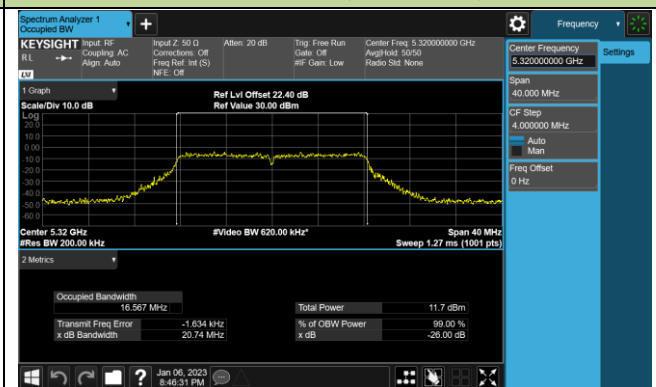

Channel 100 (5500MHz)

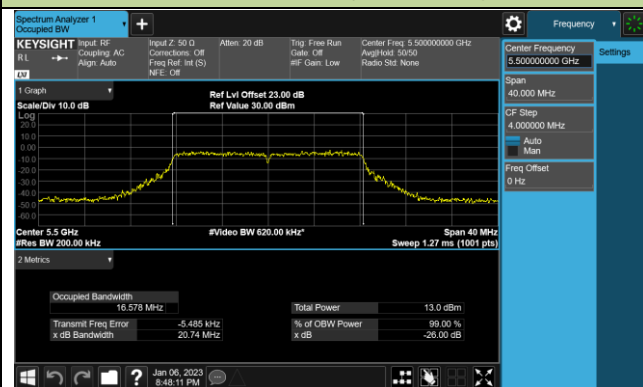

Channel 116 (5580MHz)

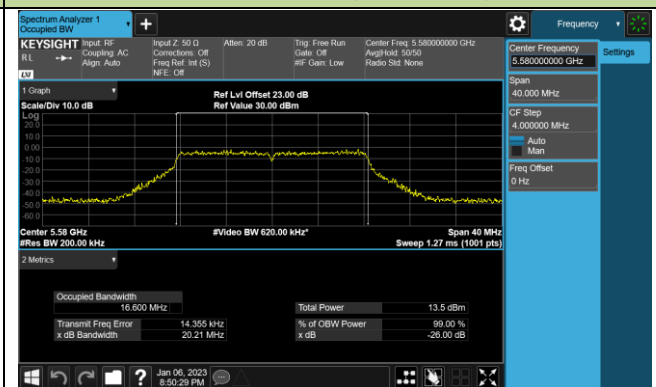

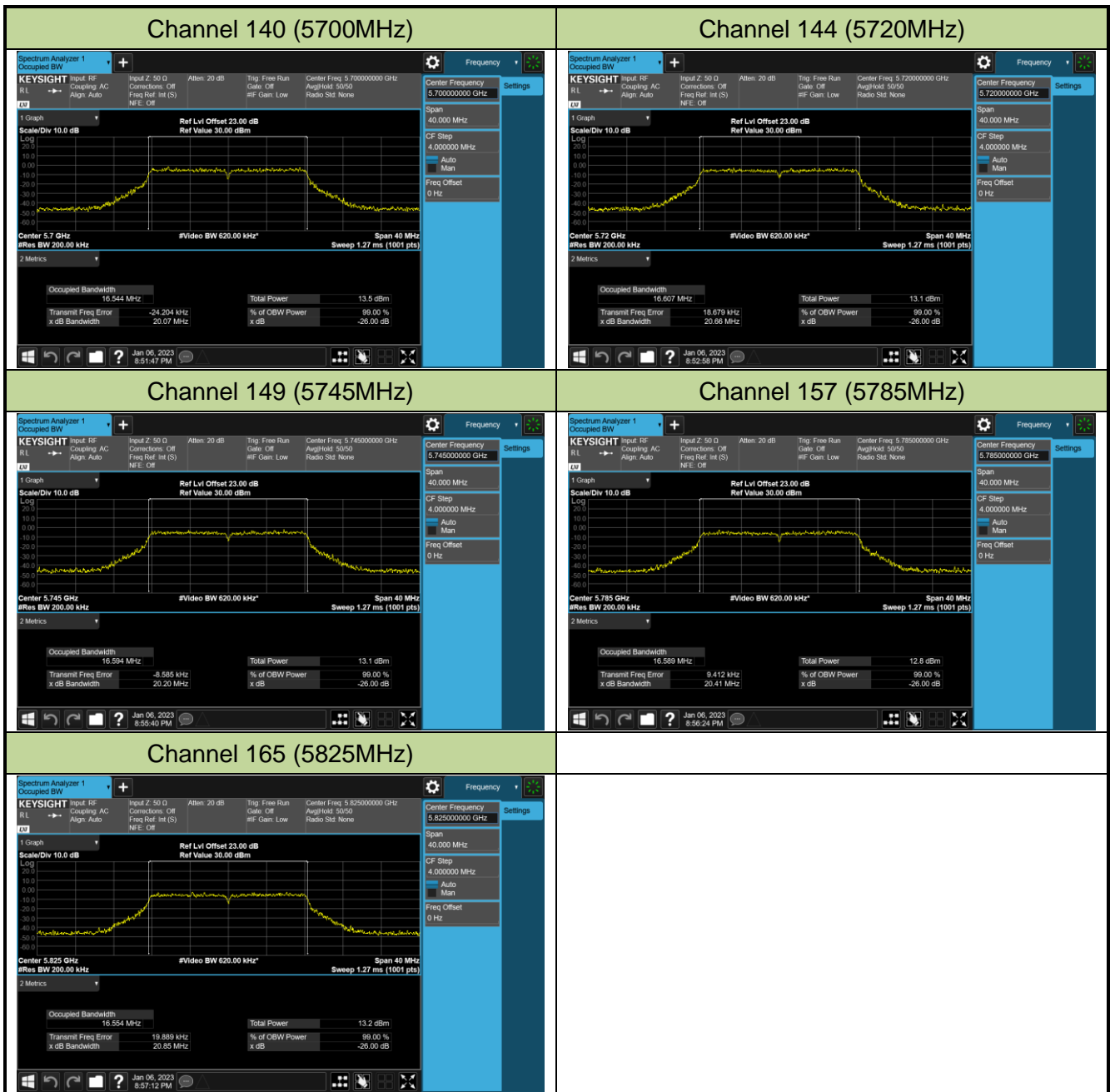

802.11ac-VHT20 26dB Bandwidth & 99% Bandwidth

Channel 36 (5180MHz)

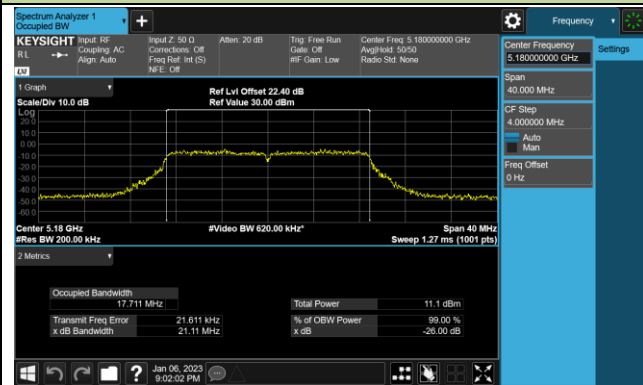

Channel 44 (5220MHz)

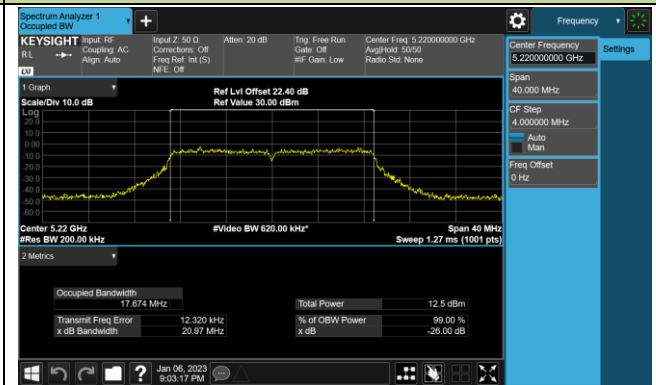

Channel 48 (5240MHz)

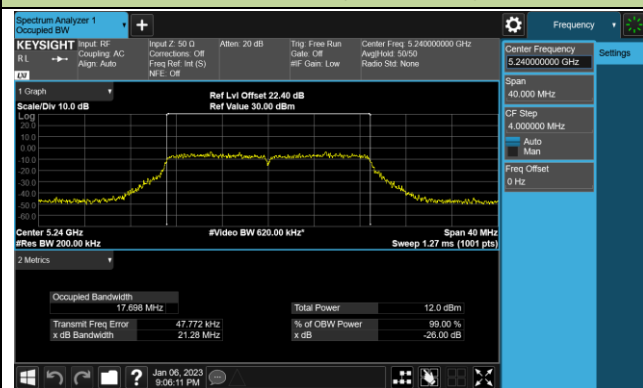

Channel 52 (5260MHz)

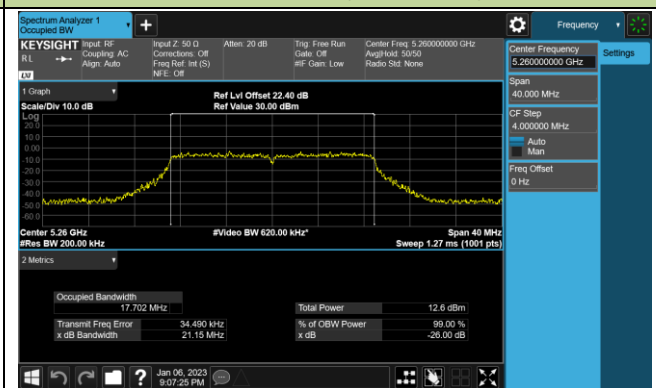

Channel 60 (5300MHz)

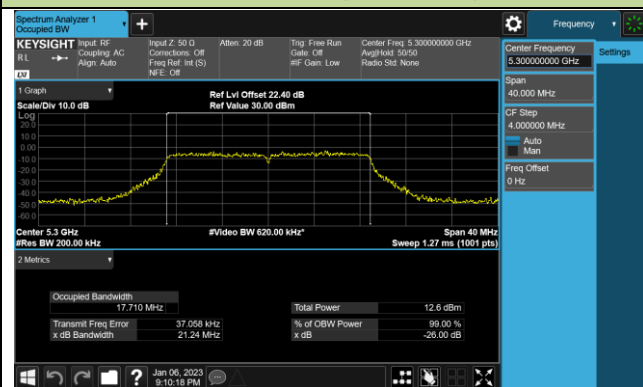

Channel 64 (5320MHz)

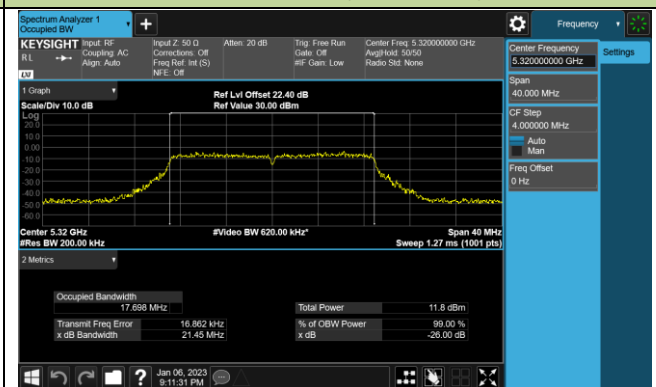

Channel 100 (5500MHz)

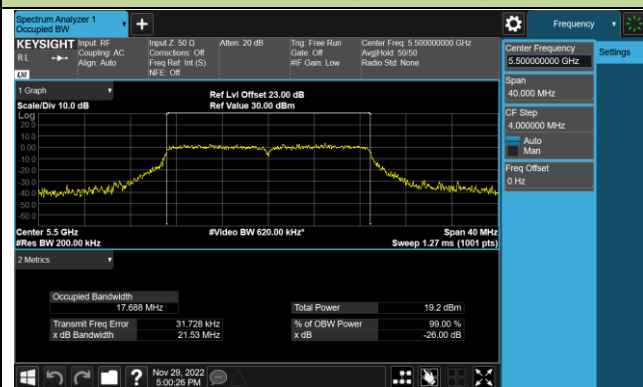

Channel 116 (5580MHz)

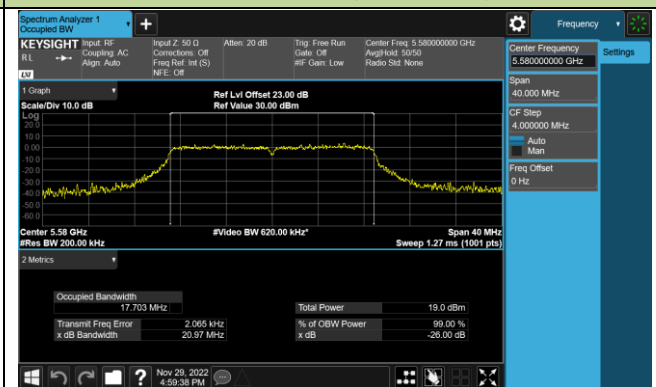

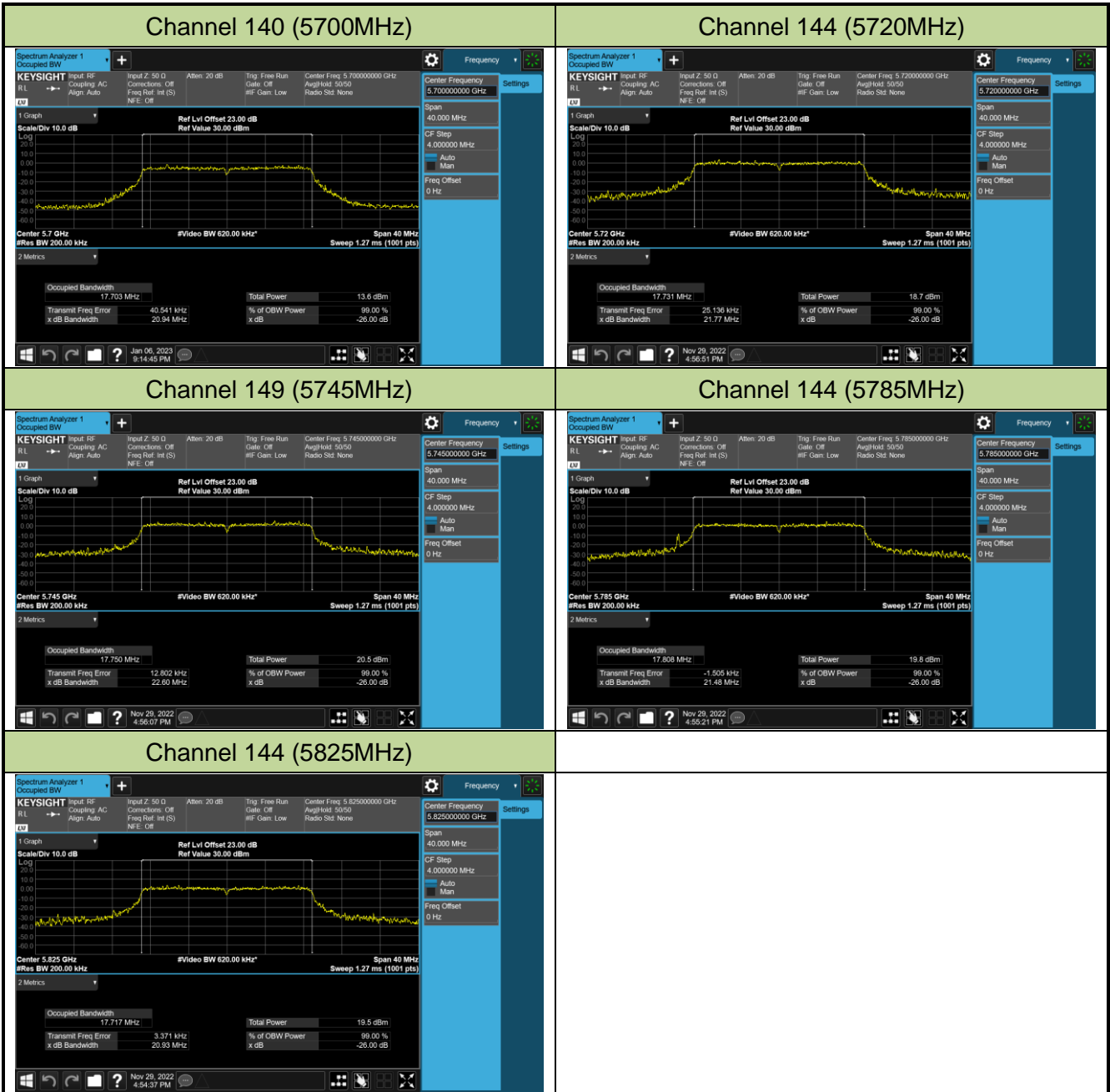

802.11ac-VHT40 26dB Bandwidth & 99% Bandwidth

Channel 38 (5190MHz)

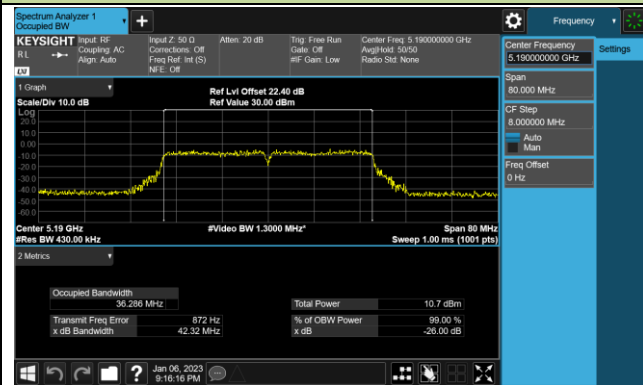

Channel 46 (5230MHz)

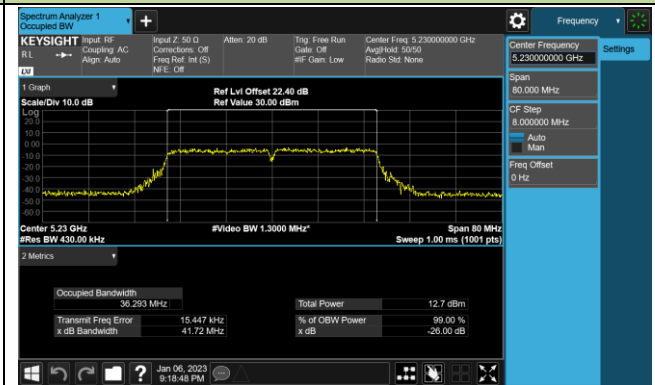

Channel 54 (5270MHz)

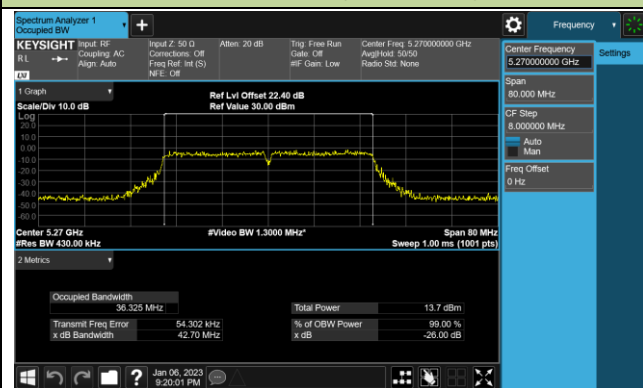

Channel 62 (5310MHz)

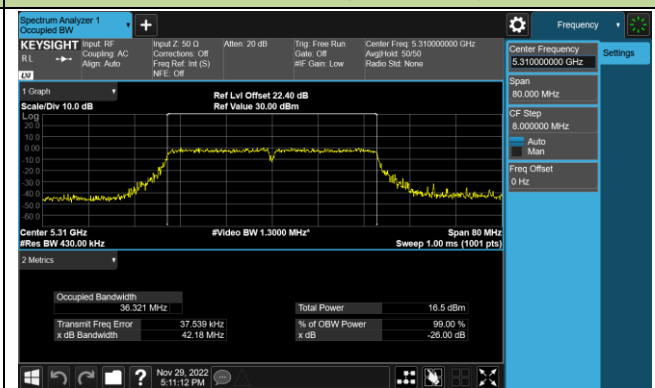

Channel 102 (5510MHz)

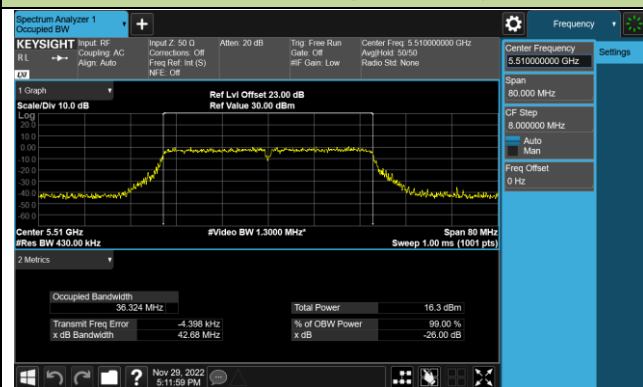

Channel 110 (5550MHz)

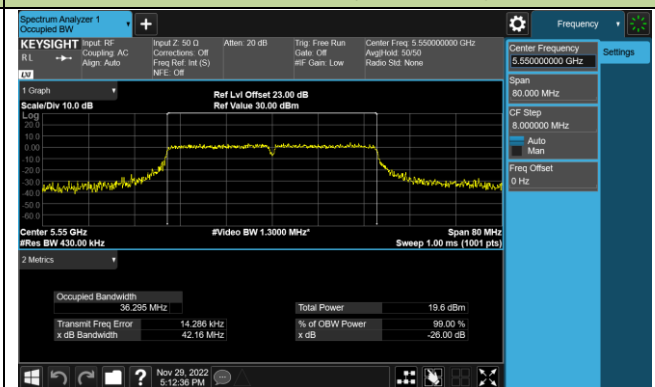

Channel 134 (5670MHz)

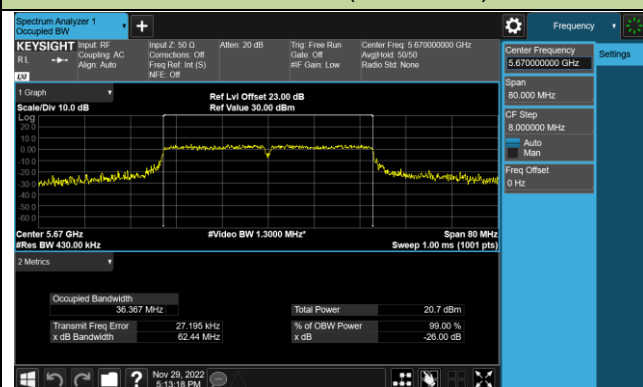

Channel 142 (5710MHz)

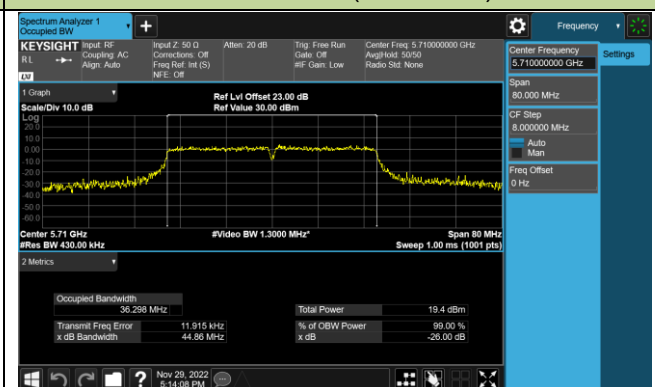

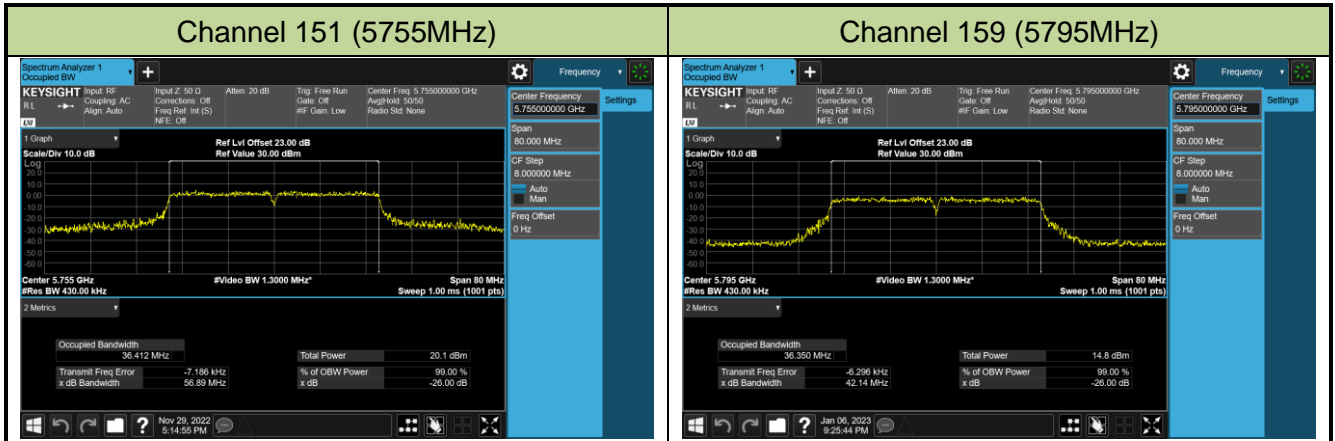

8802.11ac-VHT80 26dB Bandwidth & 99% Bandwidth

Channel 42 (5210MHz)

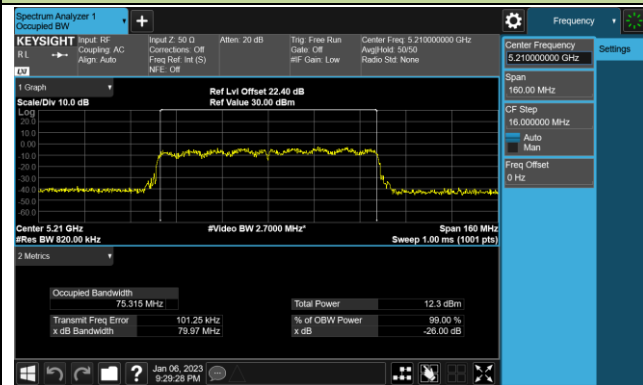

Channel 58 (5290MHz)

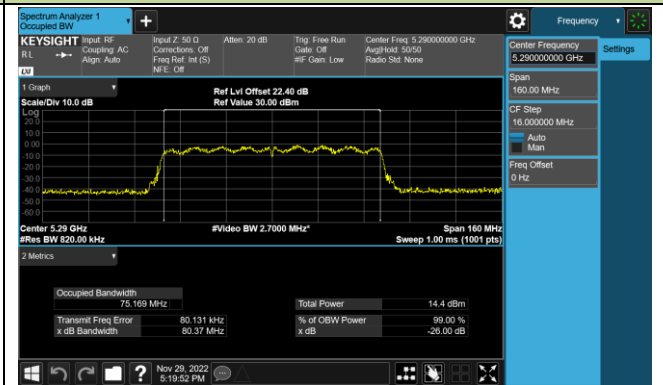

Channel 106 (5530MHz)

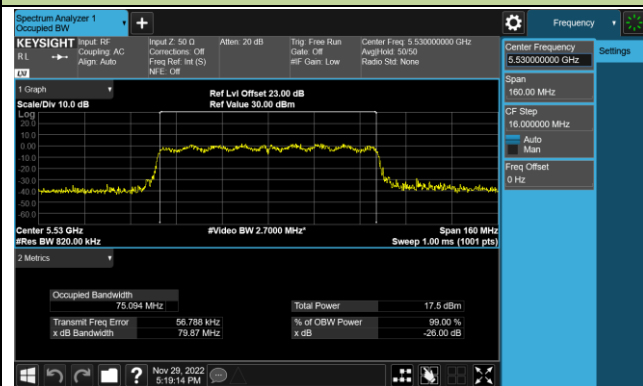

Channel 122 (5610MHz)

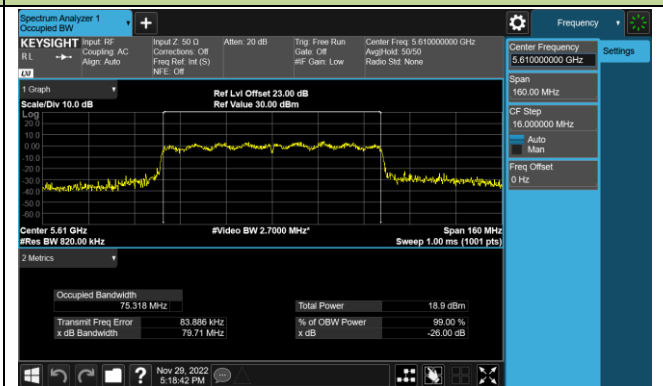

Channel 138 (5690MHz)

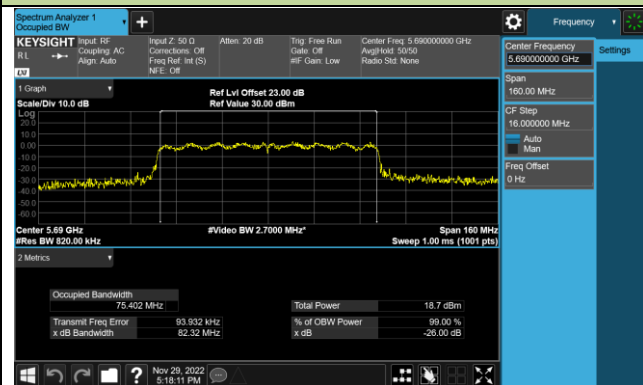

Channel 155 (5775MHz)

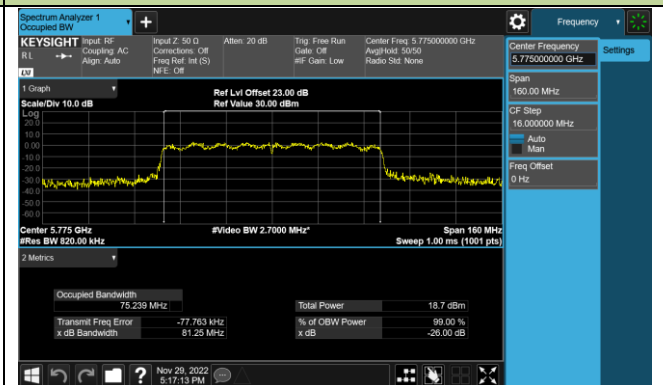

7.3. 6dB Bandwidth Measurement

7.3.1. Test Limit

The minimum 6dB bandwidth shall be at least 500 kHz.

7.3.2. Test Procedure used

KDB 789033 D02v02r01 - Section II)C.2

7.3.3. Test Setting

1. Set center frequency to the nominal EUT channel center frequency.
2. RBW = 100 kHz.
3. VBW $\geq 3 \times$ RBW.
4. Detector = Peak.
5. Trace mode = max hold.
6. Sweep = auto couple.
7. Allow the trace to stabilize.
8. Measure the maximum width of the emission that is constrained by the frequencies associated with the two outermost amplitude points (upper and lower frequencies) that are attenuated by 6 dB relative to the maximum level measured in the fundamental emission.

7.3.4. Test Setup

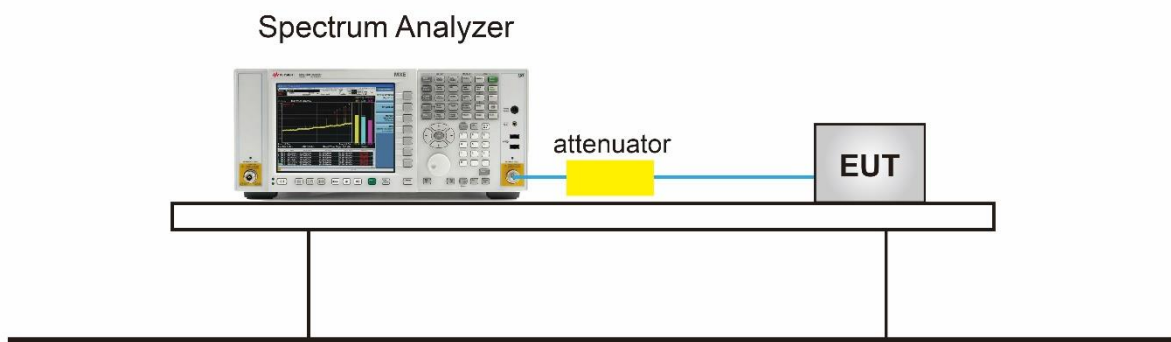

7.3.5. Test Result

Product	AC1300 High Gain Wireless Dual Band USB Adapter	Test Engineer	Marvin
Test Site	SR6	Test Date	2022/11/29~2023/1/6
Test Item	6dB Bandwidth		

Test Mode	Channel No.	Frequency (MHz)	6dB Bandwidth (MHz)	Limit (MHz)	Result
Ant 0					
802.11a	149	5745	16.380	≥ 0.5	Pass
802.11a	157	5785	16.390	≥ 0.5	Pass
802.11a	165	5825	16.370	≥ 0.5	Pass
802.11ac-VHT20	149	5745	17.620	≥ 0.5	Pass
802.11ac-VHT20	157	5785	17.270	≥ 0.5	Pass
802.11ac-VHT20	165	5825	17.590	≥ 0.5	Pass
802.11ac-VHT40	151	5755	36.290	≥ 0.5	Pass
802.11ac-VHT40	159	5795	36.310	≥ 0.5	Pass
802.11ac-VHT80	155	5775	74.570	≥ 0.5	Pass

802.11a 6dB Bandwidth

Channel 149 (5745MHz)

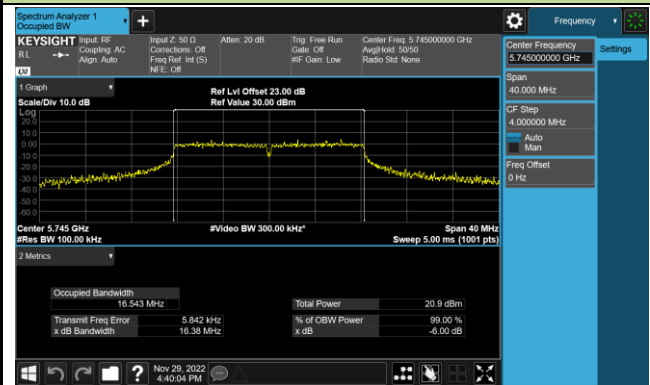

Channel 157 (5785MHz)

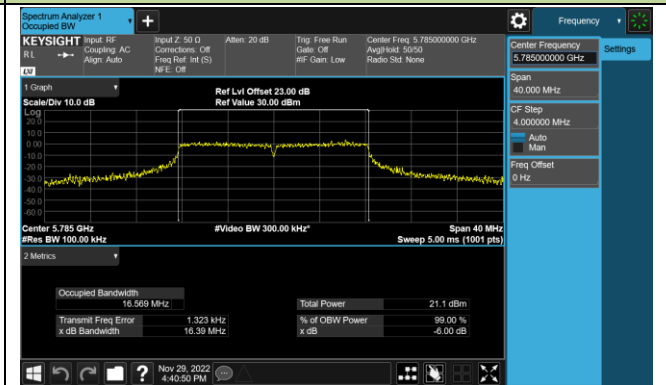

Channel 165 (5825MHz)

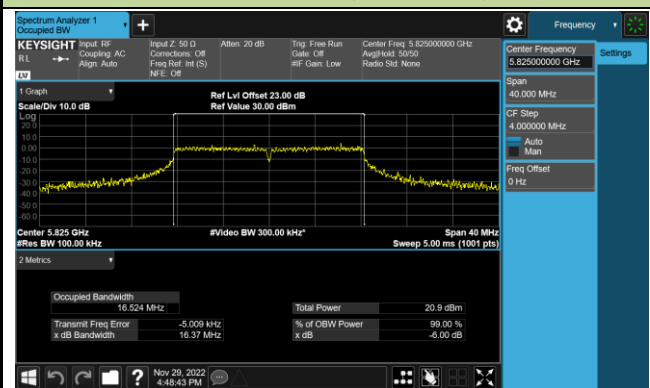

802.11ac-VHT20 6dB Bandwidth

Channel 149 (5745MHz)

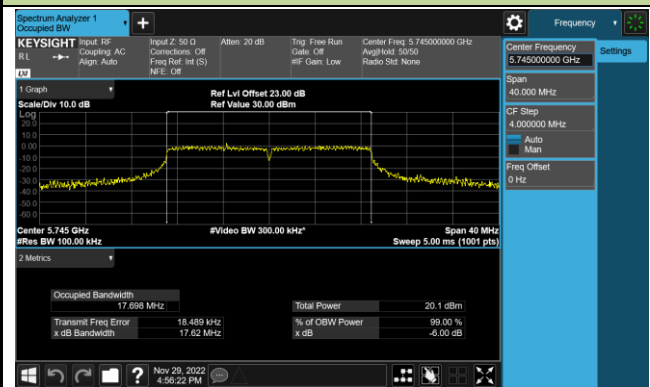

Channel 157 (5785MHz)

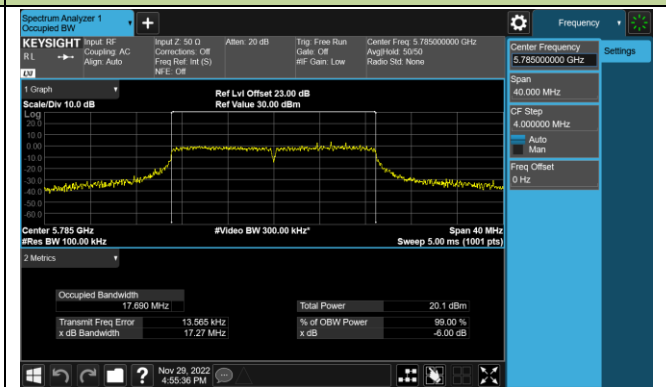

Channel 165 (5825MHz)

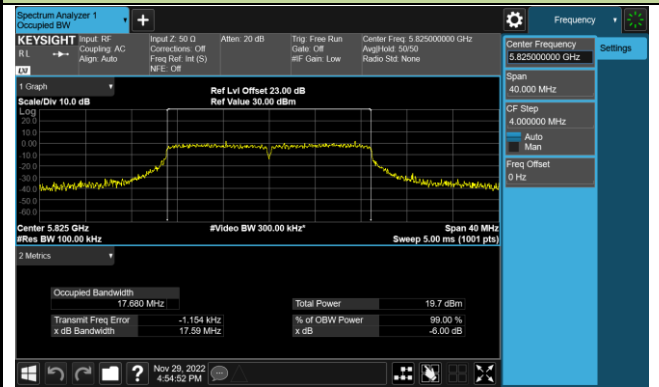

802.11ac-VHT40 6dB Bandwidth

Channel 151 (5755MHz)

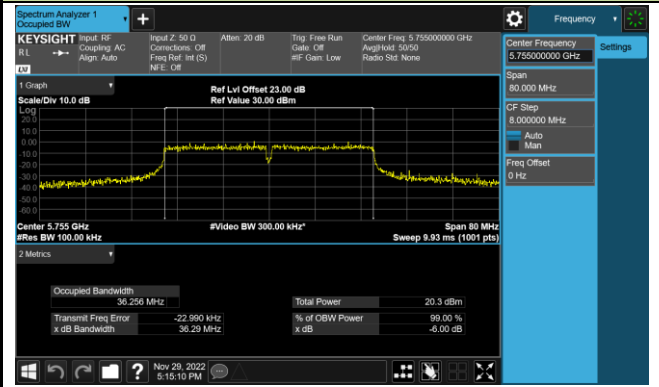

Channel 159 (5795MHz)

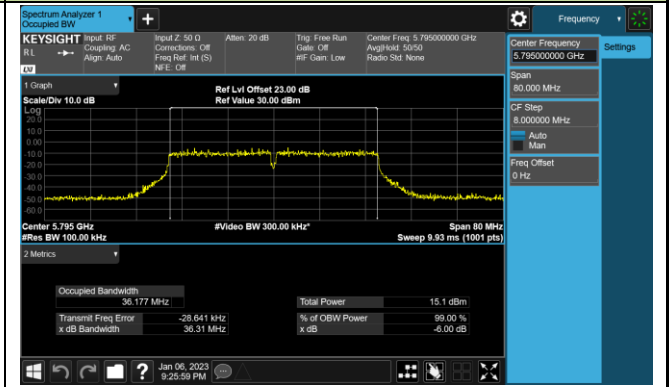

802.11ac-VHT80 6dB Bandwidth

Channel 155 (5775MHz)

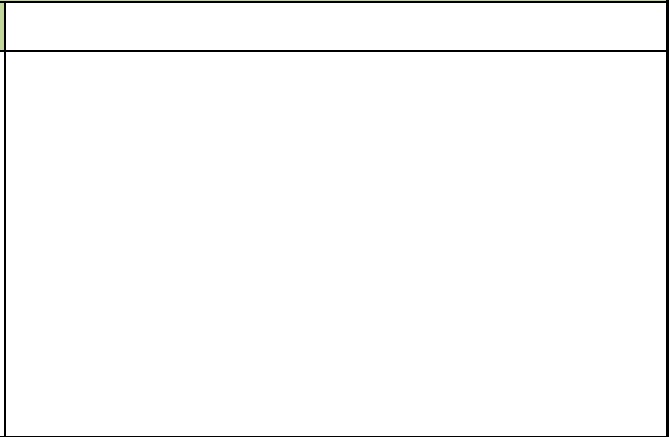
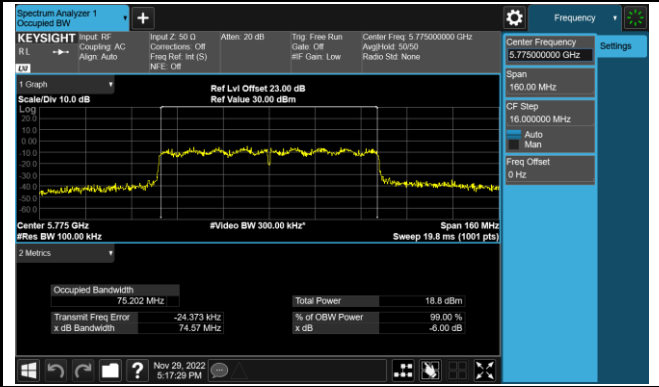

7.4. Output Power Measurement

7.4.1. Test Limit

For client devices in the 5.15-5.25 GHz band, the maximum conducted output power over the frequency band of operation shall not exceed 250 mW provided the maximum antenna gain does not exceed 6 dBi.

For the 5.25-5.35 GHz and 5.47-5.725 GHz bands, the maximum conducted output power over the frequency bands of operation shall not exceed the lesser of 250 mW or $11 \text{ dBm} + 10 \log B$, where B is the 26 dB emission bandwidth in megahertz.

For the band 5.725-5.85 GHz, the maximum conducted output power over the frequency band of operation shall not exceed 1 W (30dBm).

If transmitting antennas of directional gain greater than 6dBi are used, the maximum conducted output power shall be reduced by the amount in dB that the directional gain of the antenna exceeds 6dBi.

7.4.2. Test Procedure Used

KDB 789033 D02v02r01 - Section II) E) 3) b) Method PM-G

7.4.3. Test Setting

Average power measurements were performed only when the EUT was transmitting at its maximum power control level using a broadband power meter with a pulse sensor. The power meter implemented triggering and gating capabilities which were set up such that power measurements were recorded only during the ON time of the transmitter. The trace was averaged over 100 traces to obtain the final measured average power.

7.4.4. Test Setup

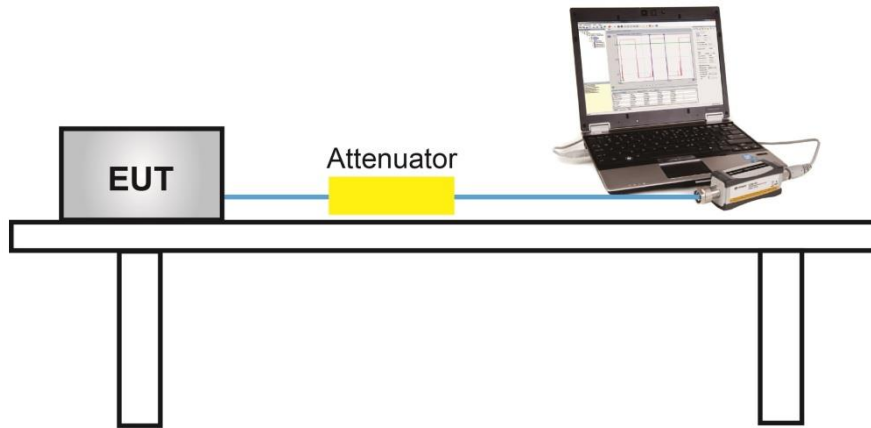

7.4.5. Test Result

Product	AC1300 High Gain Wireless Dual Band USB Adapter	Test Engineer	Marvin
Test Site	SR6	Test Date	2023/1/6

Test Mode	Data Rate/ MCS	Ch. No.	Freq. (MHz)	Average Power (dBm)	Power Limit (dBm)
11a	6Mbps	36	5180	10.87	≤ 23.98
11a	6Mbps	44	5220	11.01	≤ 23.98
11a	6Mbps	48	5240	11.17	≤ 23.98
11a	6Mbps	52	5260	11.42	≤ 23.98
11a	6Mbps	60	5300	11.23	≤ 23.98
11a	6Mbps	64	5320	11.31	≤ 23.98
11a	6Mbps	100	5500	13.30	≤ 23.98
11a	6Mbps	116	5580	13.55	≤ 23.98
11a	6Mbps	140	5700	13.80	≤ 23.98
11a	6Mbps	144	5720	13.50	≤ 22.86
11a	6Mbps	149	5745	13.33	≤ 30.00
11a	6Mbps	157	5785	12.88	≤ 30.00
11a	6Mbps	165	5825	12.91	≤ 30.00

Note 1: For 5250 - 5350 & 5470 - 5725 MHz, the conducted power limit is as below, where B is the 26 dB emission bandwidth in megahertz.

$$11 + 10 \log_{10} (B) > 23.98 \text{ dBm}$$

Note 2: For 802.11a_ch144 (5720MHz), Power Limit (dBm) = $11 + 10 * \log(5 \text{ MHz} + \text{BW}_{26 \text{ dBc}} / 2) = 22.86 \text{ dBm}$



Product	AC1300 High Gain Wireless Dual Band USB Adapter	Test Engineer	Marvin
Test Site	SR6	Test Date	2023/1/6

Test Mode	Data Rate/MCS	Channel No.	Freq. (MHz)	Ant 0 Average Power (dBm)	Ant 1 Average Power (dBm)	Total Average Power (dBm)	Power Limit (dBm)	Result
11ac-VHT20	MCS0	36	5180	12.55	13.14	15.87	≤ 23.98	Pass
11ac-VHT20	MCS0	40	5220	13.48	12.41	15.99	≤ 23.98	Pass
11ac-VHT20	MCS0	48	5240	12.87	12.95	15.92	≤ 23.98	Pass
11ac-VHT20	MCS0	52	5260	13.55	12.57	16.10	≤ 23.98	Pass
11ac-VHT20	MCS0	60	5300	13.46	12.17	15.87	≤ 23.98	Pass
11ac-VHT20	MCS0	64	5320	12.51	12.04	15.29	≤ 23.98	Pass
11ac-VHT20	MCS0	100	5500	15.24	15.19	18.23	≤ 23.98	Pass
11ac-VHT20	MCS0	116	5580	15.35	15.24	18.31	≤ 23.98	Pass
11ac-VHT20	MCS0	140	5700	15.22	14.51	17.89	≤ 23.98	Pass
11ac-VHT20	MCS0	144	5720	15.35	15.03	18.20	≤ 23.01	Pass
11ac-VHT20	MCS0	149	5745	15.17	15.15	18.17	≤ 30.00	Pass
11ac-VHT20	MCS0	157	5785	15.27	15.27	18.28	≤ 30.00	Pass
11ac-VHT20	MCS0	165	5825	15.15	15.16	18.17	≤ 30.00	Pass
11ac-VHT40	MCS0	38	5190	12.58	13.47	16.06	≤ 23.98	Pass
11ac-VHT40	MCS0	46	5230	13.35	12.59	16.00	≤ 23.98	Pass
11ac-VHT40	MCS0	54	5270	13.29	12.63	15.98	≤ 23.98	Pass
11ac-VHT40	MCS0	62	5310	13.22	12.76	16.01	≤ 23.98	Pass
11ac-VHT40	MCS0	102	5510	14.74	13.26	17.07	≤ 23.98	Pass
11ac-VHT40	MCS0	110	5550	15.25	15.51	18.39	≤ 23.98	Pass
11ac-VHT40	MCS0	134	5670	15.16	15.41	18.30	≤ 23.98	Pass
11ac-VHT40	MCS0	142	5710	15.29	15.17	18.24	≤ 23.98	Pass
11ac-VHT40	MCS0	151	5755	15.33	15.28	18.32	≤ 30.00	Pass
11ac-VHT40	MCS0	159	5795	14.55	14.21	17.39	≤ 30.00	Pass
11ac-VHT80	MCS0	42	5210	13.00	12.98	16.00	≤ 23.98	Pass
11ac-VHT80	MCS0	58	5290	12.08	11.72	14.91	≤ 23.98	Pass
11ac-VHT80	MCS0	106	5530	14.66	14.54	17.61	≤ 23.98	Pass
11ac-VHT80	MCS0	122	5610	15.29	15.39	18.35	≤ 23.98	Pass
11ac-VHT80	MCS0	138	5690	15.26	15.16	18.22	≤ 23.98	Pass
11ac-VHT80	MCS0	155	5775	15.32	15.24	18.29	≤ 30.00	Pass

Note 1:

The Total Average Power (dBm) = $10 \cdot \log \{10^{(\text{Ant 0 Average Power} / 10)} + 10^{(\text{Ant 1 Average Power} / 10)}\}$.

Note 2:

For 5250- 5350MHz and 5470 - 5725MHz Band: Average Power Limit (dBm) = 23.98 dBm.

For 5150 - 5250MHz and 5725 - 5850MHz Bands: Average Power Limit (dBm) = 30 dBm.

For 802.11ac_ch144 (5720MHz), Average Power Limit (dBm) = $11 + 10 \cdot \log(5\text{MHz} + \text{BW}_{26\text{dBc}}/2) = 23.01 \text{ dBm}$

7.5. Transmit Power Control

7.5.1. Test Limit

The U-NII device is required to have the capability to operate at least 6 dB below the mean EIRP value of 30 dBm.

7.5.2. Test Procedure Used

KDB 789033 D02v02r01 - Section E) 3) b) Method PM-G

7.5.3. Test Setting

Average power measurements were performed only when the EUT was transmitting at its maximum power control level using a broadband power meter with a pulse sensor. The power meter implemented triggering and gating capabilities which were set up such that power measurements were recorded only during the ON time of the transmitter. The trace was averaged over 100 traces to obtain the final measured average power.

7.5.4. Test Setup

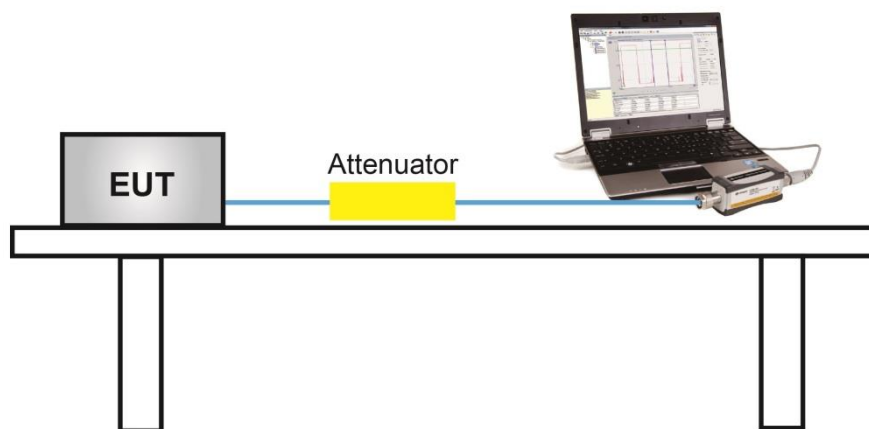

7.5.5. Test Result

A TPC mechanism is not required for systems with an e.i.r.p. of less than 500 mW.

7.6. Power Spectral Density Measurement

7.6.1. Test Limit

For the band 5.15-5.25 GHz, the maximum power spectral density shall not exceed 17 dBm in any 1 megahertz band.

For the 5.25-5.35 GHz and 5.47-5.725 GHz bands, the maximum power spectral density shall not exceed 11 dBm in any 1 megahertz band.

For the band 5.725-5.85 GHz, the maximum power spectral density shall not exceed 30 dBm in any 500-kHz band.

If transmitting antennas of directional gain greater than 6dBi are used, the peak power spectral density shall be reduced by the amount in dB that the directional gain of the antenna exceeds 6dBi.

7.6.2. Test Procedure Used

KDB 789033 D02v02r01 - Section II) F

7.6.3. Test Setting

1. Analyzer was set to the center frequency of the UNII channel under investigation
2. Span was set to encompass the entire 26dB EBW of the signal.
3. RBW = 1MHz, if measurement bandwidth of Maximum PSD is specified in 500 kHz,
RBW = 510 kHz
4. VBW = 3MHz
5. Number of sweep points $\geq 2 \times (\text{span} / \text{RBW})$
6. Detector = power averaging (Average)
7. Sweep time = auto
8. Trigger = free run
9. Use the peak search function on the instrument to find the peak of the spectrum and record its value.
10. Add $10 \cdot \log(1/x)$, where x is the duty cycle, to the measured power in order to compute the average power during the actual transmission times (because the measurement represents an average over both the on and off times of the transmission). For example, add $10 \cdot \log(1/0.25) = 6$ dB if the duty cycle is 25 percent.

7.6.4. Test Setup

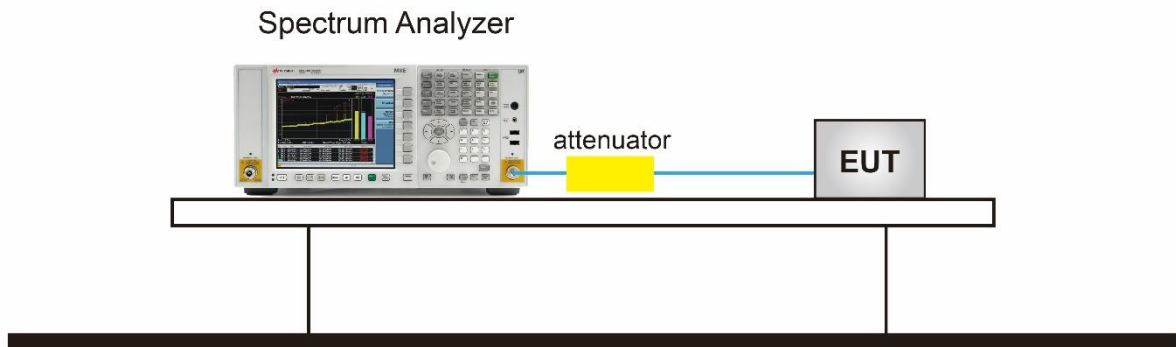

7.6.5. Test Result

Product	AC1300 High Gain Wireless Dual Band USB Adapter	Test Engineer	Marvin
Test Site	SR6	Test Date	2022/12/21~2023/1/9
Test Item	Power Spectral Density - SISO Mode		

Test Mode	Data Rate (Mbps)	Channel No.	Freq. (MHz)	PSD (dBm/MHz)	Duty Cycle (%)	Final PSD (dBm/MHz)	PSD Limit (dBm/MHz)	Result
For NII-1/-2a/-2c Bands:								
11a	6	36	5180	-0.937	97.39	-0.822	≤ 11	Pass
11a	6	44	5220	-1.020	97.39	-0.905	≤ 11	Pass
11a	6	48	5240	-0.297	97.39	-0.182	≤ 11	Pass
11a	6	52	5260	-0.034	97.39	0.081	≤ 11	Pass
11a	6	60	5300	-0.260	97.39	-0.145	≤ 11	Pass
11a	6	64	5320	-0.100	97.39	0.015	≤ 11	Pass
11a	6	100	5500	1.450	97.39	1.565	≤ 11	Pass
11a	6	120	5600	1.678	97.39	1.793	≤ 11	Pass
11a	6	140	5700	1.669	97.39	1.784	≤ 11	Pass
11a	6	144	5720	1.344	97.39	1.459	≤ 11	Pass

Note: When EUT duty cycle < 98%, the Final PSD (dBm / MHz) = PSD (dBm / MHz) + 10*log (1/Duty cycle).

Test Mode	Data Rate (Mbps)	Channel No.	Freq. (MHz)	PSD (dBm/510kHz)	Duty Cycle (%)	Final PSD (dBm/510kHz)	PSD Limit (dBm/500kHz)	Result
For NII-3 Band:								
11a	6	149	5745	-2.334	97.39	-2.219	≤ 30	Pass
11a	6	157	5785	-2.104	97.39	-1.989	≤ 30	Pass
11a	6	165	5825	-1.847	97.39	-1.732	≤ 30	Pass

Note: When EUT duty cycle < 98%, the Final PSD (dBm / 510kHz) = PSD (dBm / 510kHz) + 10*log (1/Duty cycle).

Product	AC1300 High Gain Wireless Dual Band USB Adapter	Test Engineer	Marvin
Test Site	SR6	Test Date	2022/11/25~2023/1/9
Test Item	Power Spectral Density - CDD Mode		

Test Mode	Data Rate (Mbps)	Channel No.	Freq. (MHz)	Ant 0 PSD (dBm/MHz)	Ant 1 PSD (dBm/MHz)	Duty Cycle (%)	Final PSD (dBm/MHz)	PSD Limit (dBm/MHz)	Result
11ac-VHT20	6.5	36	5180	1.254	1.291	96.97	4.416	≤ 11	Pass
11ac-VHT20	6.5	44	5220	2.191	0.881	96.97	4.729	≤ 11	Pass
11ac-VHT20	6.5	48	5240	1.619	1.668	96.97	4.787	≤ 11	Pass
11ac-VHT20	6.5	52	5260	2.364	0.584	96.97	4.708	≤ 11	Pass
11ac-VHT20	6.5	60	5300	2.444	0.589	96.97	4.759	≤ 11	Pass
11ac-VHT20	6.5	64	5320	1.945	-0.151	96.97	4.166	≤ 11	Pass
11ac-VHT20	6.5	100	5500	4.778	3.959	96.97	7.532	≤ 11	Pass
11ac-VHT20	6.5	120	5600	4.668	3.631	96.97	7.324	≤ 11	Pass
11ac-VHT20	6.5	140	5700	2.926	2.895	96.97	6.054	≤ 11	Pass
11ac-VHT20	6.5	144	5720	3.622	3.498	96.97	6.704	≤ 11	Pass
11ac-VHT40	13.5	38	5190	-4.213	-4.766	88.96	-0.962	≤ 11	Pass
11ac-VHT40	13.5	46	5230	-2.453	-3.944	88.96	0.384	≤ 11	Pass
11ac-VHT40	13.5	54	5270	-2.277	-3.218	88.96	0.796	≤ 11	Pass
11ac-VHT40	13.5	62	5310	-3.148	-3.879	88.96	0.020	≤ 11	Pass
11ac-VHT40	13.5	102	5510	-4.661	-5.539	88.96	-1.559	≤ 11	Pass
11ac-VHT40	13.5	110	5550	-0.594	-0.299	88.96	3.074	≤ 11	Pass
11ac-VHT40	13.5	134	5670	-0.806	-1.097	88.96	2.569	≤ 11	Pass
11ac-VHT40	13.5	142	5710	0.921	0.409	88.96	4.191	≤ 11	Pass
11ac-VHT80	29.3	42	5210	-7.375	-8.284	76.71	-3.644	≤ 11	Pass
11ac-VHT80	29.3	58	5290	-8.923	-11.813	76.71	-5.970	≤ 11	Pass
11ac-VHT80	29.3	106	5530	-7.339	-8.790	76.71	-3.842	≤ 11	Pass
11ac-VHT80	29.3	122	5610	-5.439	-5.789	76.71	-1.449	≤ 11	Pass
11ac-VHT80	29.3	138	5690	-6.170	-5.632	76.71	-1.731	≤ 11	Pass

Note: When EUT duty cycle < 98%,

the Final PSD (dBm/MHz) = $10 \cdot \log \{ 10^{(\text{Ant 0 PSD}/10)} + 10^{(\text{Ant 1 PSD}/10)} \} + 10 \cdot \log (1/\text{Duty Cycle})(\text{dBm/MHz})$.

Test Mode	Data Rate (Mbps)	Channel No.	Freq. (MHz)	Ant 0 PSD (dBm/510kHz)	Ant 1 PSD (dBm/510kHz)	Duty Cycle (%)	Final PSD (dBm/510kHz)	PSD Limit (dBm/500 kHz)	Result
11ac-VHT20	6.5	149	5745	1.556	0.129	96.97	4.045	≤ 30	Pass
11ac-VHT20	6.5	157	5785	-0.649	-1.321	96.97	2.172	≤ 30	Pass
11ac-VHT20	6.5	165	5825	-1.626	-0.852	96.97	1.922	≤ 30	Pass
11ac-VHT40	13.5	151	5755	-5.522	-4.983	88.96	-1.726	≤ 30	Pass
11ac-VHT40	13.5	159	5795	-3.223	-5.209	88.96	-0.585	≤ 30	Pass
11ac-VHT80	29.3	155	5775	-9.016	-10.197	76.71	-5.405	≤ 30	Pass

Note: When EUT duty cycle < 98%, the Final PSD (dBm / 510kHz) = $10 \cdot \log \{10^{(\text{Ant 0 PSD} / 10)} + 10^{(\text{Ant 1 PSD} / 10)}\} + 10 \cdot \log (1/\text{Duty cycle})$.

802.11a Power Spectral Density - Ant 0

Channel 36 (5180MHz)

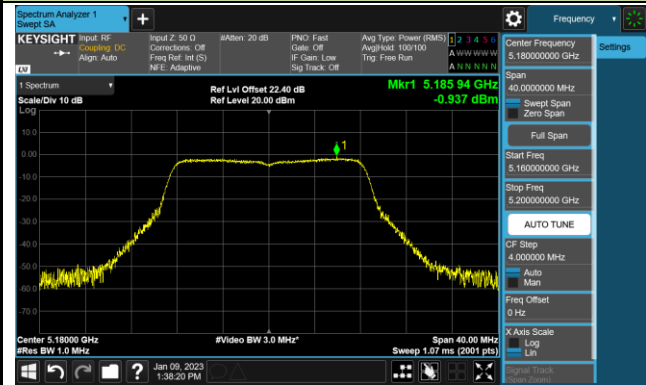

Channel 44 (5220MHz)

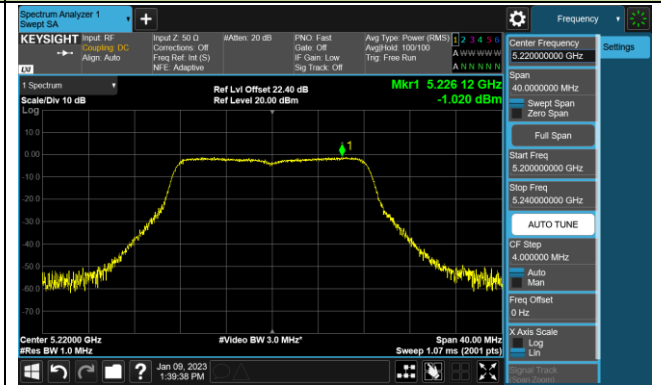

Channel 48 (5240MHz)

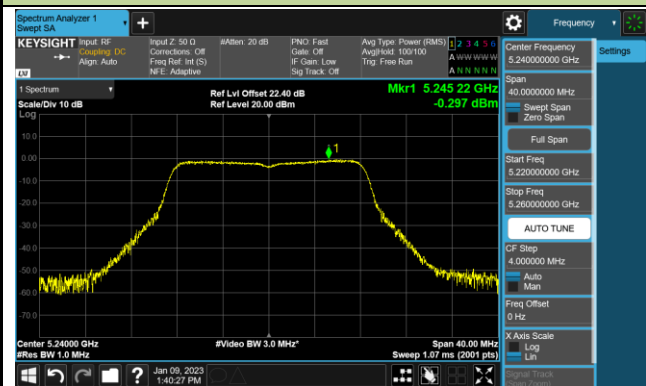

Channel 52 (5260MHz)

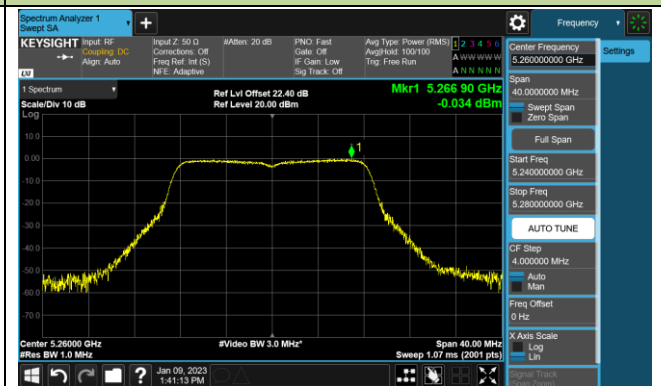

Channel 60 (5300MHz)

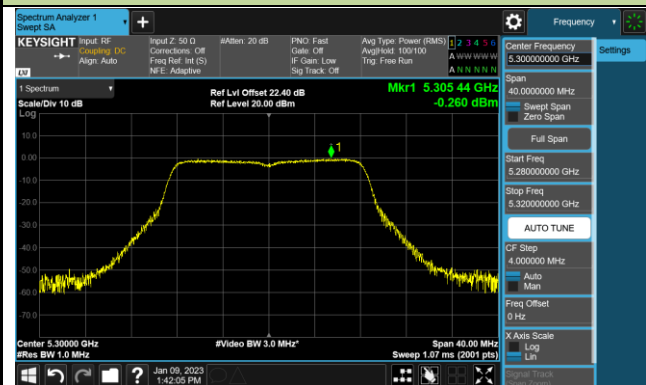

Channel 64 (5320MHz)

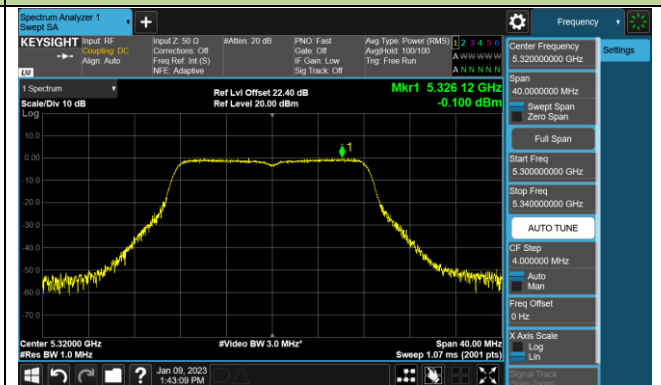

Channel 100 (5500MHz)

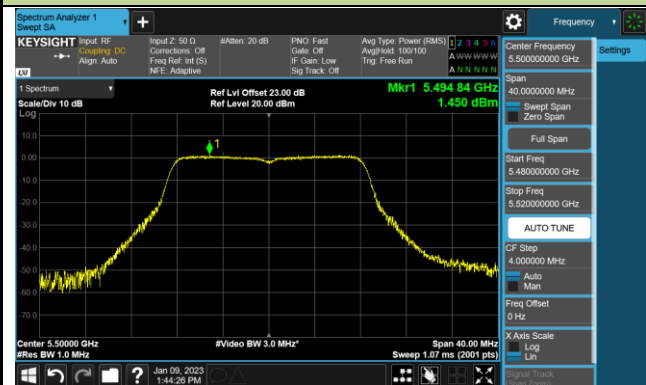

Channel 116 (5580MHz)

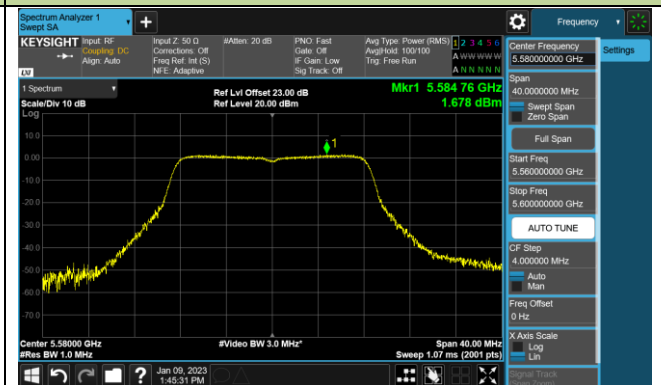

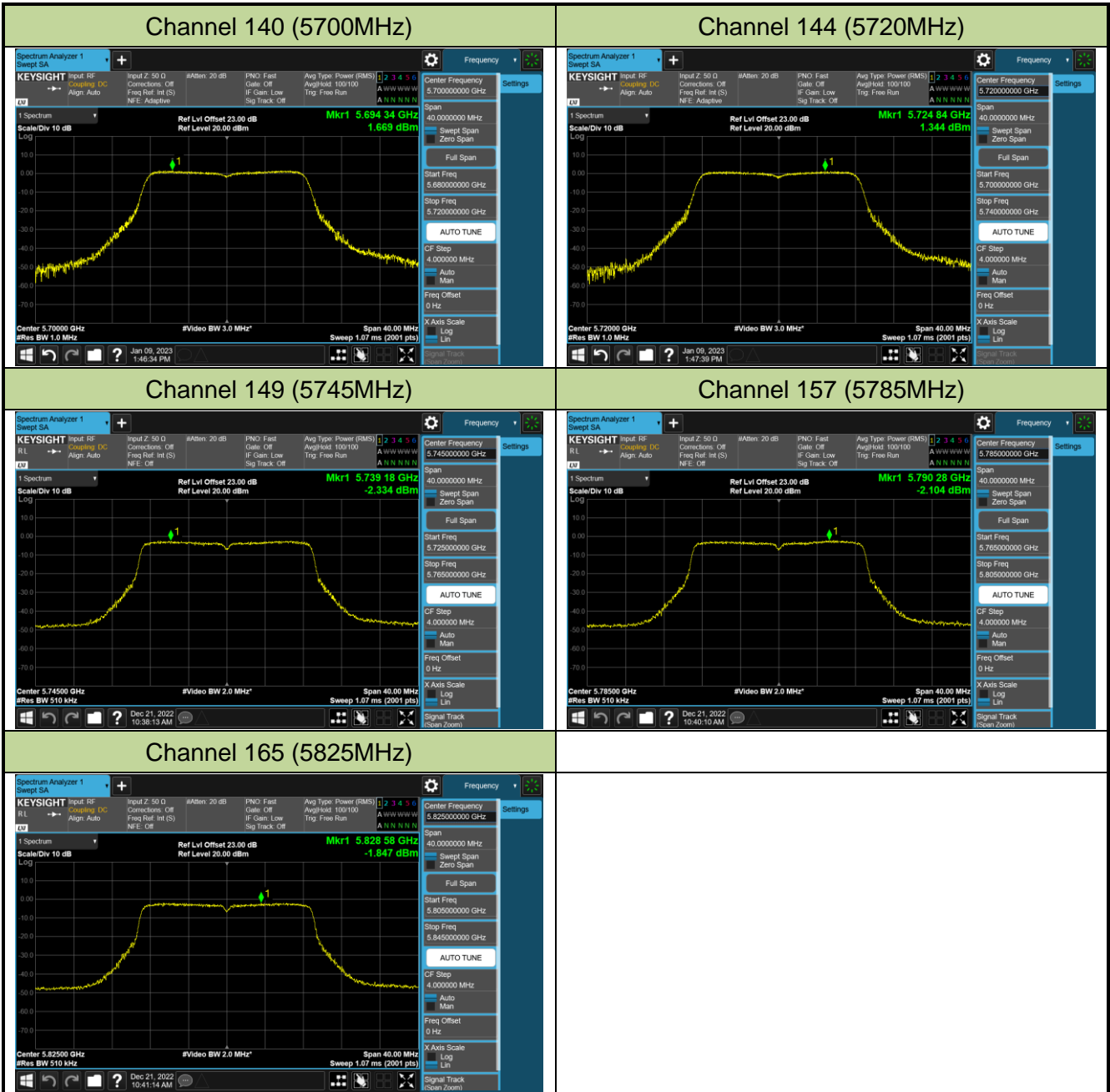

802.11ac-VHT20 Power Spectral Density - Ant 0

Channel 36 (5180MHz)

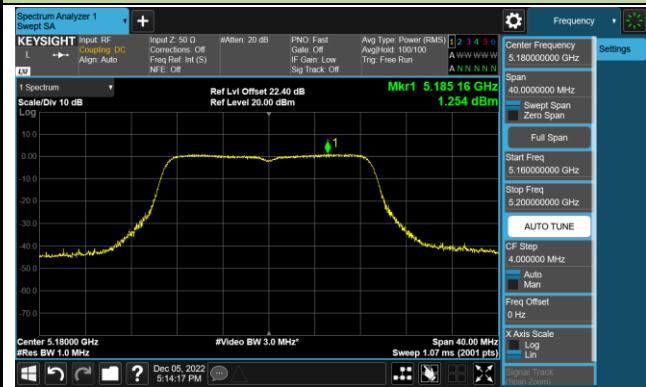

Channel 44 (5220MHz)

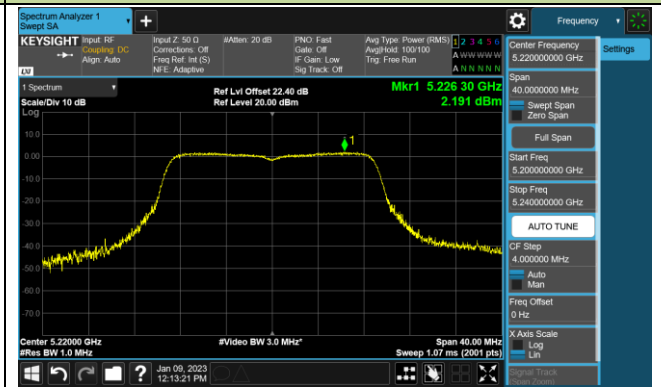

Channel 48 (5240MHz)

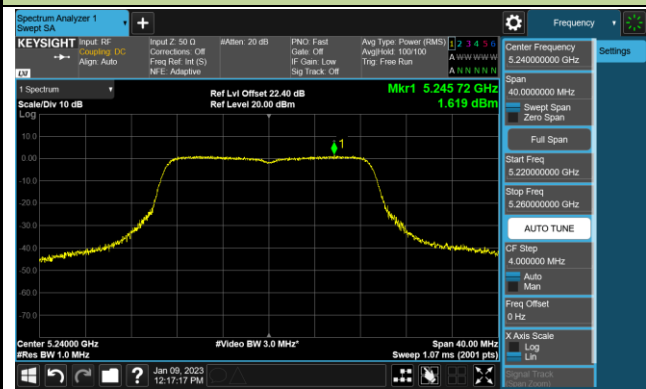

Channel 52 (5260MHz)

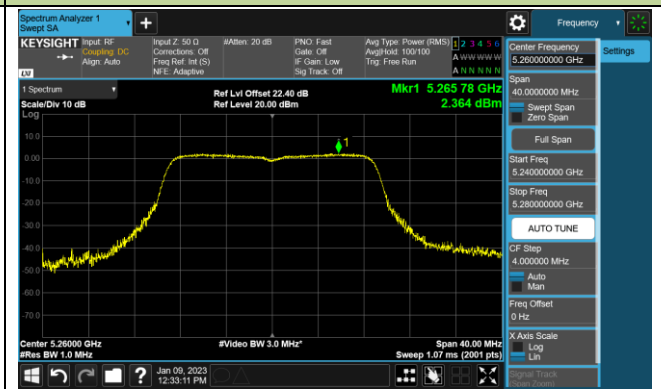

Channel 60 (5300MHz)

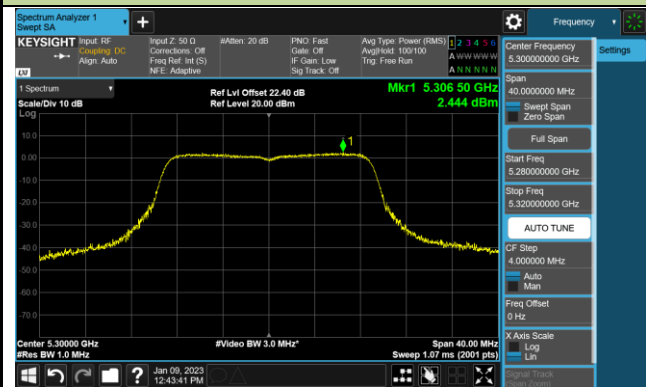

Channel 64 (5320MHz)

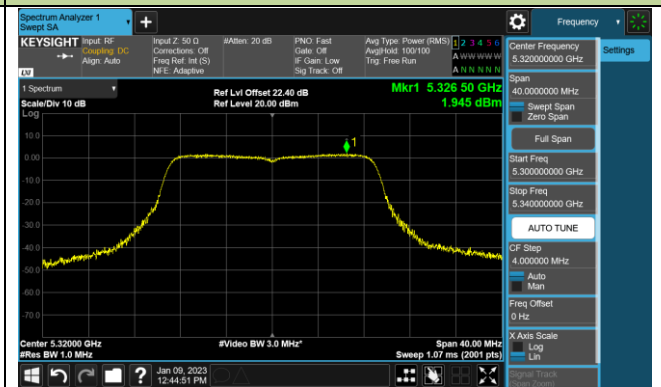

Channel 100 (5500MHz)

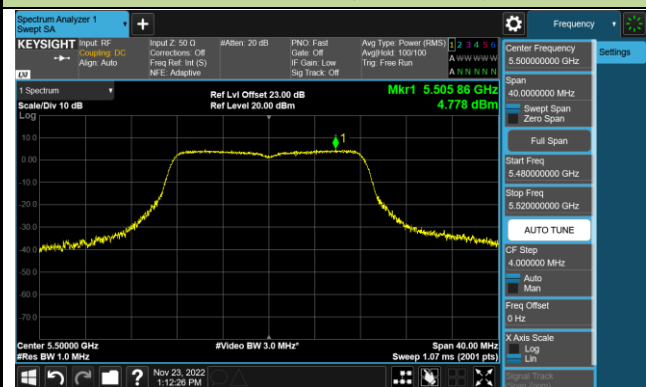

Channel 116 (5580MHz)

