

FCC Test Report

Report No.: RF180419C48-1

FCC ID: TYM-K155

Test Model: K155

Received Date: Apr. 19, 2018

Test Date: May 11 ~ May 17, 2018

Issued Date: May 24, 2018

Applicant: AVAYA

Address: 250 Sidney Street, Belleville, Ontario , K8P 3Z3 ,Canada

Issued By: Bureau Veritas Consumer Products Services (H.K.) Ltd., Taoyuan Branch

Lab Address: No. 47-2, 14th Ling, Chia Pau Vil., Lin Kou Dist., New Taipei City, Taiwan (R.O.C.)

Test Location: No. 19, Hwa Ya 2nd Rd., Wen Hwa Vil., Kwei Shan Dist., Taoyuan City 33383, TAIWAN (R.O.C.)

**FCC Registration /
Designation Number:** 788550 / TW0003



This report is for your exclusive use. Any copying or replication of this report to or for any other person or entity, or use of our name or trademark, is permitted only with our prior written permission. This report sets forth our findings solely with respect to the test samples identified herein. The results set forth in this report are not indicative or representative of the quality or characteristics of the lot from which a test sample was taken or any similar or identical product unless specifically and expressly noted. Our report includes all of the tests requested by you and the results thereof based upon the information that you provided to us. You have 60 days from date of issuance of this report to notify us of any material error or omission caused by our negligence, provided, however, that such notice shall be in writing and shall specifically address the issue you wish to raise. A failure to raise such issue within the prescribed time shall constitute your unqualified acceptance of the completeness of this report, the tests conducted and the correctness of the report contents. Unless specific mention, the uncertainty of measurement has been explicitly taken into account to declare the compliance or non-compliance to the specification. The report must not be used by the client to claim product certification, approval, or endorsement by TAF or any government agencies.

Table of Contents

Release Control Record	4
1 Certificate of Conformity	5
2 Summary of Test Results	6
2.1 Measurement Uncertainty.....	6
2.2 Modification Record.....	6
3 General Information	7
3.1 General Description of EUT.....	7
3.2 Description of Test Modes.....	8
3.2.1 Test Mode Applicability and Tested Channel Detail.....	9
3.3 Duty Cycle of Test Signal.....	11
3.4 Description of Support Units.....	12
3.4.1 Configuration of System under Test.....	12
3.5 General Description of Applied Standards.....	12
4 Test Types and Results	13
4.1 Radiated Emission and Bandedge Measurement.....	13
4.1.1 Limits of Radiated Emission and Bandedge Measurement.....	13
4.1.2 Test Instruments.....	14
4.1.3 Test Procedures.....	15
4.1.4 Deviation from Test Standard.....	15
4.1.5 Test Setup.....	16
4.1.6 EUT Operating Conditions.....	17
4.1.7 Test Results.....	18
4.2 Conducted Emission Measurement.....	37
4.2.1 Limits of Conducted Emission Measurement.....	37
4.2.2 Test Instruments.....	37
4.2.3 Test Procedures.....	38
4.2.4 Deviation from Test Standard.....	38
4.2.5 Test Setup.....	38
4.2.6 EUT Operating Conditions.....	38
4.2.7 Test Results.....	39
4.3 Transmit Power Measurement.....	41
4.3.1 Limits of Transmit Power Measurement.....	41
4.3.2 Test Setup.....	41
4.3.3 Test Instruments.....	41
4.3.4 Test Procedure.....	42
4.3.5 Deviation from Test Standard.....	42
4.3.6 EUT Operating Conditions.....	42
4.3.7 Test Result.....	43
4.4 Occupied Bandwidth Measurement.....	44
4.4.1 Test Setup.....	44
4.4.2 Test Instruments.....	44
4.4.3 Test Procedure.....	44
4.4.4 Test Result.....	45
4.5 Peak Power Spectral Density Measurement.....	47
4.5.1 Limits of Peak Power Spectral Density Measurement.....	47
4.5.2 Test Setup.....	47
4.5.3 Test Instruments.....	47
4.5.4 Test Procedures.....	47
4.5.5 Deviation from Test Standard.....	48
4.5.6 EUT Operating Conditions.....	48
4.5.7 Test Results.....	49
4.6 Frequency Stability.....	53
4.6.1 Limits of Frequency Stability Measurement.....	53

4.6.2	Test Setup.....	53
4.6.3	Test Instruments	53
4.6.4	Test Procedure	53
4.6.5	Deviation from Test Standard	53
4.6.6	EUT Operating Condition	53
4.6.7	Test Results	54
4.7	6dB Bandwidth Measurement.....	55
4.7.1	Limits of 6dB Bandwidth Measurement.....	55
4.7.2	Test Setup.....	55
4.7.3	Test Instruments	55
4.7.4	Test Procedure	55
4.7.5	Deviation from Test Standard	55
4.7.6	EUT Operating Condition	55
4.7.7	Test Results	56
5	Pictures of Test Arrangements.....	58
	Annex A- Radiated Out of Band Emission (OOBE) Measurement (For U-NII-3 band).....	59
	Appendix – Information on the Testing Laboratories	62

Release Control Record

Issue No.	Description	Date Issued
RF180419C48-1	Original release	May 24, 2018

1 Certificate of Conformity

Product: IP Phone
Brand: AVAYA
Test Model: K155
Sample Status: Engineering sample
Applicant: AVAYA
Test Date: May 11 ~ May 17, 2018
Standards: 47 CFR FCC Part 15, Subpart E (Section 15.407)
ANSI C63.10:2013

The above equipment has been tested by **Bureau Veritas Consumer Products Services (H.K.) Ltd., Taoyuan Branch**, and found compliance with the requirement of the above standards. The test record, data evaluation & Equipment Under Test (EUT) configurations represented herein are true and accurate accounts of the measurements of the sample's RF characteristics under the conditions specified in this report.

Prepared by : Celine Chou , **Date:** May 24, 2018
Celine Chou / Specialist

Approved by : Bruce Chen , **Date:** May 24, 2018
Bruce Chen / Project Engineer

2 Summary of Test Results

47 CFR FCC Part 15, Subpart E (Section 15.407)			
FCC Clause	Test Item	Result	Remarks
15.407(b)(6)	AC Power Conducted Emissions	Pass	Meet the requirement of limit. Minimum passing margin is -8.60dB at 0.40055MHz.
15.407(b)(1/2/3/4(i/ii)/6)	Radiated Emissions & Band Edge Measurement	Pass	Meet the requirement of limit. Minimum passing margin is -1.1dB at 5150.00MHz.
15.407(a)(1/2/3)	Max Average Transmit Power	Pass	Meet the requirement of limit.
---	Occupied Bandwidth Measurement	-	Reference only.
15.407(a)(1/2/3)	Peak Power Spectral Density	Pass	Meet the requirement of limit.
15.407(e)	6dB bandwidth	Pass	Meet the requirement of limit. (U-NII-3 Band only)
15.407(g)	Frequency Stability	Pass	Meet the requirement of limit.
15.203	Antenna Requirement	Pass	No antenna connector is used.

*For U-NII-3 band compliance with rule part 15.407(b)(4)(i), the OOB test plots were recorded in Annex A.

2.1 Measurement Uncertainty

Where relevant, the following measurement uncertainty levels have been estimated for tests performed on the EUT as specified in CISPR 16-4-2:

Measurement	Frequency	Expanded Uncertainty (k=2) (±)
Conducted Emissions at mains ports	150kHz ~ 30MHz	2.94 dB
Radiated Emissions up to 1 GHz	30MHz ~ 200MHz	3.86 dB
	200MHz ~ 1000MHz	3.87 dB
Radiated Emissions above 1 GHz	1GHz ~ 18GHz	2.29 dB
	18GHz ~ 40GHz	2.29 dB

2.2 Modification Record

There were no modifications required for compliance.

3 General Information

3.1 General Description of EUT

Product	IP Phone
Brand	AVAYA
Test Model	K155
Sample Status	Engineering sample
Power Supply Rating	48Vdc from Adapter
Modulation Type	256QAM, 64QAM, 16QAM, QPSK, BPSK
Modulation Technology	OFDM
Transfer Rate	802.11a: 54/48/36/24/18/12/9/6Mbps 802.11n: up to 72.2Mbps 802.11ac: up to 433.3Mbps
Operating Frequency	5180 ~ 5240MHz, 5745 ~ 5825MHz
Number of Channel	5180 ~ 5240MHz: 802.11a, 802.11n (HT20), 802.11ac (VHT20): 4 802.11n (HT40), 802.11ac (VHT40): 2 802.11ac (VHT80): 1 5745 ~ 5825MHz: 802.11a, 802.11n (HT20), 802.11ac (VHT20): 5 802.11n (HT40), 802.11ac (VHT40): 2 802.11ac (VHT80): 1
Output Power	5180 ~ 5240MHz: 19.320mW 5745 ~ 5825MHz: 19.099mW
Antenna Type	Chip antenna with 2.4dBi gain
Antenna Connector	NA
Accessory Device	Adapter
Cable Supplied	NA

Note:

1. The EUT provides 1 completed transmitter and 1 receiver.

Modulation Mode	TX Function
802.11a	1TX
802.11n (HT20)	1TX
802.11n (HT40)	1TX
802.11ac (VHT20)	1TX
802.11ac (VHT40)	1TX
802.11ac (VHT80)	1TX

* The modulation and bandwidth are similar for 802.11n mode for 20MHz/40MHz and 802.11ac mode for 20MHz/40MHz, therefore investigated worst case to representative mode in test report. (Final test mode refer section 3.2.1)

2. The EUT consumes power from the following Adapter.

Adapter	
Brand	DELTA Electronics, INC.
Model	ADP-30HR B
Input Power	100-240ac, 1A, 50-60Hz
Output Power	48Vdc, 0.66A
Power Line	1.7m AC power cable without core 1.45m DC power cable with one core attached on adapter

3. WLAN and BT technologies cannot transmit at same time; WLAN 2.4GHz and WLAN 5GHz technologies cannot transmit at same time.

3.2 Description of Test Modes

For 5180 ~ 5240MHz:

4 channels are provided for 802.11a, 802.11n (HT20), 802.11ac (VHT20):

Channel	Frequency	Channel	Frequency
36	5180 MHz	44	5220 MHz
40	5200 MHz	48	5240 MHz

2 channels are provided for 802.11n (HT40), 802.11ac (VHT40):

Channel	Frequency	Channel	Frequency
38	5190 MHz	46	5230 MHz

1 channel is provided for 802.11ac (VHT80):

Channel	Frequency
42	5210MHz

For 5745 ~ 5825MHz:

5 channels are provided for 802.11a, 802.11n (HT20), 802.11ac (VHT20):

Channel	Frequency	Channel	Frequency
149	5745MHz	161	5805MHz
153	5765MHz	165	5825MHz
157	5785MHz		

2 channels are provided for 802.11n (HT40), 802.11ac (VHT40):

Channel	Frequency	Channel	Frequency
151	5755MHz	159	5795MHz

1 channel is provided for 802.11ac (VHT80):

Channel	Frequency
155	5775MHz

3.2.1 Test Mode Applicability and Tested Channel Detail

EUT Configure Mode	Applicable to				Description
	RE \geq 1G	RE<1G	PLC	APCM	
-	√	√	√	√	-

Where RE \geq 1G: Radiated Emission above 1GHz & Bandedge Measurement
 RE<1G: Radiated Emission below 1GHz
 PLC: Power Line Conducted Emission
 APCM: Antenna Port Conducted Measurement

Note: The EUT had been pre-tested on the positioned of each 3 axis. The worst case was found when positioned on **Z-plane**.

Radiated Emission Test (Above 1GHz):

- Pre-Scan has been conducted to determine the worst-case mode from all possible combinations between available modulations, data rates and antenna ports (if EUT with antenna diversity architecture).
- Following channel(s) was (were) selected for the final test as listed below.

EUT Configure Mode	Mode	Frequency Band (MHz)	Available Channel	Tested Channel	Modulation Technology	Data Rate (Mbps)
-	802.11a	5180-5240	36 to 48	36, 40, 48	OFDM	6.0
	802.11n (HT20)		36 to 48	36, 40, 48	OFDM	6.5
	802.11n (HT40)		38 to 46	38, 46	OFDM	13.5
	802.11ac (VHT80)		42	42	OFDM	29.3
-	802.11a	5745-5825	149 to 165	149, 157, 165	OFDM	6.0
	802.11n (HT20)		149 to 165	149, 157, 165	OFDM	6.5
	802.11n (HT40)		151 to 159	151, 159	OFDM	13.5
	802.11ac (VHT80)		155	155	OFDM	29.3

Radiated Emission Test (Below 1GHz):

- Pre-Scan has been conducted to determine the worst-case mode from all possible combinations between available modulations, data rates and antenna ports (if EUT with antenna diversity architecture).
- Following channel(s) was (were) selected for the final test as listed below.

EUT Configure Mode	Mode	Frequency Band (MHz)	Available Channel	Tested Channel	Modulation Technology	Data Rate (Mbps)
-	802.11a	5180-5240	36 to 48	40	OFDM	6.0
	802.11a	5745-5825	149 to 165		OFDM	6.0

Power Line Conducted Emission Test:

- Pre-Scan has been conducted to determine the worst-case mode from all possible combinations between available modulations, data rates and antenna ports (if EUT with antenna diversity architecture).
- Following channel(s) was (were) selected for the final test as listed below.

EUT Configure Mode	Mode	Frequency Band (MHz)	Available Channel	Tested Channel	Modulation Technology	Data Rate (Mbps)
-	802.11a	5180-5240	36 to 48	40	OFDM	6.0
	802.11a	5745-5825	149 to 165		OFDM	6.0

Antenna Port Conducted Measurement:

- This item includes all test value of each mode, but only includes spectrum plot of worst value of each mode.
- Pre-Scan has been conducted to determine the worst-case mode from all possible combinations between available modulations, data rates and antenna ports (if EUT with antenna diversity architecture).
- Following channel(s) was (were) selected for the final test as listed below.

EUT Configure Mode	Mode	Frequency Band (MHz)	Available Channel	Tested Channel	Modulation Technology	Data Rate (Mbps)
-	802.11a	5180-5240	36 to 48	36, 40, 48	OFDM	6.0
	802.11n (HT20)		36 to 48	36, 40, 48	OFDM	6.5
	802.11n (HT40)		38 to 46	38, 46	OFDM	13.5
	802.11ac (VHT80)		42	42	OFDM	29.3
-	802.11a	5745-5825	149 to 165	149, 157, 165	OFDM	6.0
	802.11n (HT20)		149 to 165	149, 157, 165	OFDM	6.5
	802.11n (HT40)		151 to 159	151, 159	OFDM	13.5
	802.11ac (VHT80)		155	155	OFDM	29.3

Test Condition:

Applicable to	Environmental Conditions	Input Power	Tested by
RE _≥ 1G	23 deg. C, 67% RH	120Vac, 60Hz	Willy Cheng
RE _{<} 1G	23 deg. C, 67% RH	120Vac, 60Hz	Willy Cheng
PLC	25 deg. C, 70% RH	120Vac, 60Hz	Matthew Yang
APCM	25 deg. C, 60% RH	120Vac, 60Hz	Chris Lin

3.3 Duty Cycle of Test Signal

802.11n (HT40), 802.11ac (VHT80): Duty cycle of test signal is > 98%, duty factor is not required.

802.11a, 802.11n (HT20): Duty cycle of test signal is < 98%, duty factor is required.

802.11a: Duty cycle = $0.103/0.106 = 0.972$, Duty factor = $10 * \log(1/0.972) = 0.12$

802.11n (HT20): Duty cycle = $0.103/0.106 = 0.972$, Duty factor = $10 * \log(1/0.972) = 0.12$

802.11n (HT40): Duty cycle = $1198.450/1203.400 = 0.996$

802.11ac (VHT80): Duty cycle = $370.012/373.462 = 0.991$

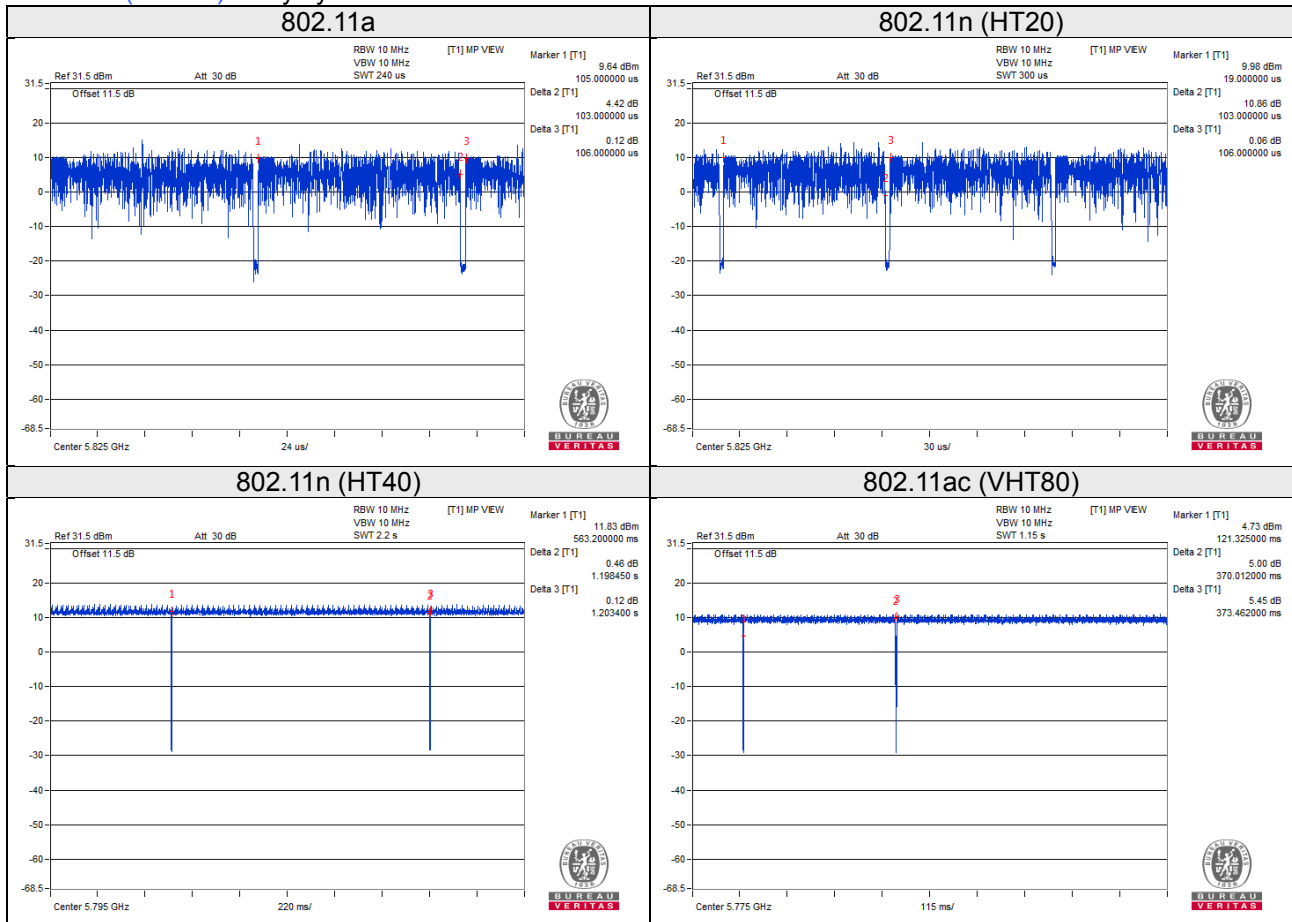

3.4 Description of Support Units

The EUT has been tested as an independent unit together with other necessary accessories or support units. The following support units or accessories were used to form a representative test configuration during the tests.

ID	Product	Brand	Model No.	Serial No.	FCC ID	Remarks
A.	Eaphone	PHILIPS	SBC HL150	NA	NA	-
B.	USB Flash	HP	v250W	01	NA	-
C.	Load	NA	NA	NA	NA	-
D.	Load	NA	NA	NA	NA	-

Note: All power cords of the above support units are non-shielded (1.8m).

ID	Descriptions	Qty.	Length (m)	Shielding (Yes/No)	Cores (Qty.)	Remarks
1.	Earphone	1	1.5	N	0	Attached on adapter
2.	RJ45, Cat5e	1	3	N	0	-
	RJ45, Cat5e	1	1.5	N	0	-
3.	Phone	1	0.5	N	0	-

3.4.1 Configuration of System under Test

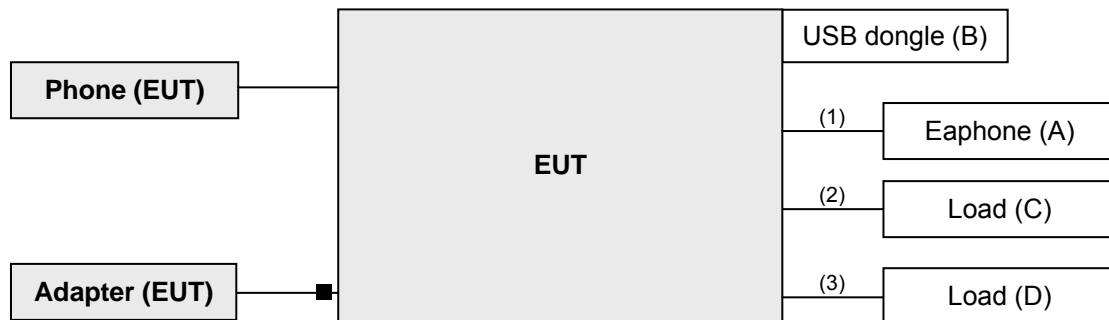

3.5 General Description of Applied Standards

The EUT is a RF Product. According to the specifications of the manufacturer, it must comply with the requirements of the following standards:

FCC Part 15, Subpart E (15.407)

KDB 789033 D02 General UNII Test Procedure New Rules v02r01

ANSI C63.10:2013

All test items have been performed and recorded as per the above standards.

4 Test Types and Results

4.1 Radiated Emission and Bandedge Measurement

4.1.1 Limits of Radiated Emission and Bandedge Measurement

Radiated emissions which fall in the restricted bands must comply with the radiated emission limits specified as below table.

Frequencies (MHz)	Field Strength (microvolts/meter)	Measurement Distance (meters)
0.009 ~ 0.490	2400/F(kHz)	300
0.490 ~ 1.705	24000/F(kHz)	30
1.705 ~ 30.0	30	30
30 ~ 88	100	3
88 ~ 216	150	3
216 ~ 960	200	3
Above 960	500	3

Note:

1. The lower limit shall apply at the transition frequencies.
2. Emission level (dBuV/m) = 20 log Emission level (uV/m).
3. For frequencies above 1000MHz, the field strength limits are based on average detector, however, the peak field strength of any emission shall not exceed the maximum permitted average limits, specified above by more than 20dB under any condition of modulation.

Limits of unwanted emission out of the restricted bands

Applicable To		Limit	
789033 D02 General UNII Test Procedure New Rules v02r01		Field Strength at 3m	
		PK: 74 (dBµV/m)	AV: 54 (dBµV/m)
Frequency Band	Applicable To	EIRP Limit	Equivalent Field Strength at 3m
5150~5250 MHz	15.407(b)(1)	PK: -27 (dBm/MHz)	PK: 68.2(dBµV/m)
5250~5350 MHz	15.407(b)(2)		
5470~5725 MHz	15.407(b)(3)		
5725~5850 MHz	<input checked="" type="checkbox"/> 15.407(b)(4)(i)	PK: -27 (dBm/MHz) ^{*1} PK: 10 (dBm/MHz) ^{*2} PK: 15.6 (dBm/MHz) ^{*3} PK: 27 (dBm/MHz) ^{*4}	PK: 68.2(dBµV/m) ^{*1} PK: 105.2 (dBµV/m) ^{*2} PK: 110.8(dBµV/m) ^{*3} PK: 122.2 (dBµV/m) ^{*4}
	<input type="checkbox"/> 15.407(b)(4)(ii)	Emission limits in section 15.247(d)	
^{*1} beyond 75 MHz or more above of the band edge.		^{*2} below the band edge increasing linearly to 10 dBm/MHz at 25 MHz above.	
^{*3} below the band edge increasing linearly to a level of 15.6 dBm/MHz at 5 MHz above.		^{*4} from 5 MHz above or below the band edge increasing linearly to a level of 27 dBm/MHz at the band edge.	

Note: The following formula is used to convert the equipment isotropic radiated power (eirp) to field strength:

$$E = \frac{1000000 \sqrt{30P}}{3} \mu\text{V/m, where P is the eirp (Watts).}$$

4.1.2 Test Instruments

Description & Manufacturer	Model No.	Serial No.	Cal. Date	Cal. Due
Test Receiver ROHDE & SCHWARZ	ESCI	100424	Oct. 17, 2017	Oct. 16, 2018
Spectrum Analyzer ROHDE & SCHWARZ	FSP40	100041	Dec. 12, 2017	Dec. 11, 2018
BILOG Antenna SCHWARZBECK	VULB9168	9168-171	Dec. 11, 2017	Dec. 10, 2018
HORN Antenna SCHWARZBECK	9120D	209	Dec. 13, 2017	Dec. 12, 2018
HORN Antenna SCHWARZBECK	BBHA 9170	BBHA9170241	Dec. 01, 2017	Nov. 30, 2018
Loop Antenna EMCI	EM-6879	269	Aug. 11, 2017	Aug. 10, 2018
Preamplifier Agilent (Below 1GHz)	8447D	2944A10738	Aug. 21, 2017	Aug. 20, 2018
Preamplifier Agilent (Above 1GHz)	8449B	3008A02465	Apr. 03, 2018	Apr. 02, 2019
RF signal cable HUBER+SUHNER	SUCOFLEX 104	Cable-CH3-03 (223653/4)	Aug. 21, 2017	Aug. 20, 2018
RF signal cable HUBER+SUHNER& EMCI	SUCOFLEX 104&EMC104-SM-SM-8 000	Cable-CH3-03 (309224+170907)	Sep.11, 2017	Sep. 10, 2018
Software BV ADT	ADT_Radiated_ V7.6.15.9.4	NA	NA	NA
Antenna Tower inn-co GmbH	MA 4000	013303	NA	NA
Antenna Tower Controller BV ADT	AT100	AT93021702	NA	NA
Turn Table BV ADT	TT100	TT93021702	NA	NA
Turn Table Controller BV ADT	SC100	SC93021702	NA	NA
Boresight Antenna Fixture	FBA-01	FBA-SIP01	NA	NA
26GHz ~ 40GHz Amplifier Agilent	8449B	3008A1960	Aug. 08, 2017	Aug. 07, 2018
High Speed Peak Power Meter	ML2495A	0824012	Aug. 18, 2017	Aug. 17, 2018
Power Sensor	MA2411B	0738171	Aug. 18, 2017	Aug. 17, 2018
WIT Standard Temperature And Humidity Chamber	TH-4S-C	W981030	Jun. 07, 2017	Jun. 06, 2018
AC Power Supply Extech	CFW-105	E000603	NA	NA

- Note: 1. The calibration interval of the above test instruments is 12 months and the calibrations are traceable to NML/ROC and NIST/USA.
2. The test was performed in HwaYa Chamber 3.
3. The horn antenna and preamplifier (model: 8449B) are used only for the measurement of emission frequency above 1GHz if tested.
4. The FCC Designation Number is TW0003. The number will be varied with the Lab location and scope as attached.
5. The IC Site Registration No. is IC 7450F-3.

4.1.3 Test Procedures

For Radiated emission below 30MHz

- a. The EUT was placed on the top of a rotating table 0.8 meters above the ground at a 3 meter chamber room. The table was rotated 360 degrees to determine the position of the highest radiation.
- b. The EUT was set 3 meters away from the interference-receiving antenna, which was mounted on the top of a variable-height antenna tower.
- c. Parallel, perpendicular, and ground-parallel orientations of the antenna are set to make the measurement.
- d. For each suspected emission, the EUT was arranged to its worst case and the rotatable table was turned from 0 degrees to 360 degrees to find the maximum reading.
- e. The test-receiver system was set to Quasi-Peak Detect Function and Specified Bandwidth with Maximum Hold Mode.

Note:

1. The resolution bandwidth and video bandwidth of test receiver/spectrum analyzer is 9kHz at frequency below 30MHz.

For Radiated emission above 30MHz

- a. The EUT was placed on the top of a rotating table 0.8 meters (for 30MHz ~ 1GHz) / 1.5 meters (for above 1GHz) above the ground at 3 meter chamber room for test. The table was rotated 360 degrees to determine the position of the highest radiation.
- b. The EUT was set 3 meters away from the interference-receiving antenna, which was mounted on the top of a variable-height antenna tower.
- c. The height of antenna is varied from one meter to four meters above the ground to determine the maximum value of the field strength. Both horizontal and vertical polarizations of the antenna are set to make the measurement.
- d. For each suspected emission, the EUT was arranged to its worst case and then the antenna was tuned to heights from 1 meter to 4 meters and the rotatable table was turned from 0 degrees to 360 degrees to find the maximum reading.
- e. The test-receiver system was set to quasi-peak detect function and specified bandwidth with maximum hold mode when the test frequency is below 1 GHz.
- f. The test-receiver system was set to peak and average detect function and specified bandwidth with maximum hold mode when the test frequency is above 1 GHz. If the peak reading value also meets average limit, measurement with the average detector is unnecessary.

Note:

1. The resolution bandwidth and video bandwidth of test receiver/spectrum analyzer is 120kHz for Quasi-peak detection (QP) at frequency below 1GHz.
2. The resolution bandwidth of test receiver/spectrum analyzer is 1 MHz and the video bandwidth is 3 MHz for Peak detection (PK) at frequency above 1GHz.
3. The resolution bandwidth of test receiver/spectrum analyzer is 1MHz and the video bandwidth is $\geq 1/T$ (Duty cycle < 98%) or 10Hz (Duty cycle $\geq 98\%$) for Average detection (AV) at frequency above 1GHz.
4. All modes of operation were investigated and the worst-case emissions are reported.

4.1.4 Deviation from Test Standard

No deviation.

4.1.5 Test Setup

For Radiated emission below 30MHz

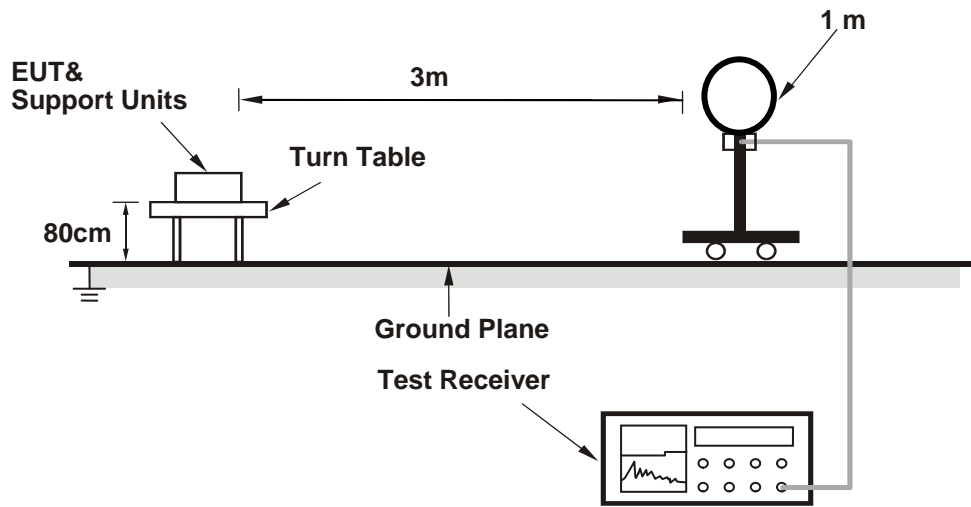

For Radiated emission 30MHz to 1GHz

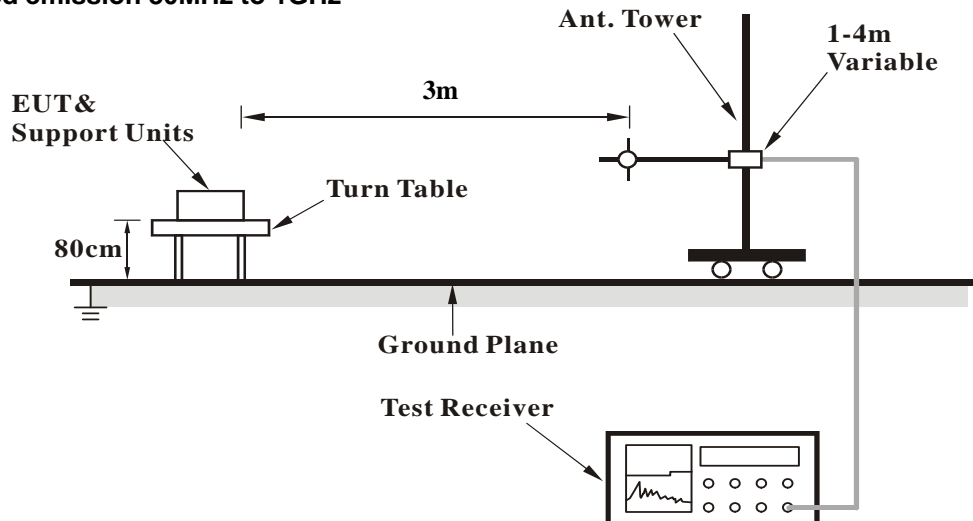

For Radiated emission above 1GHz

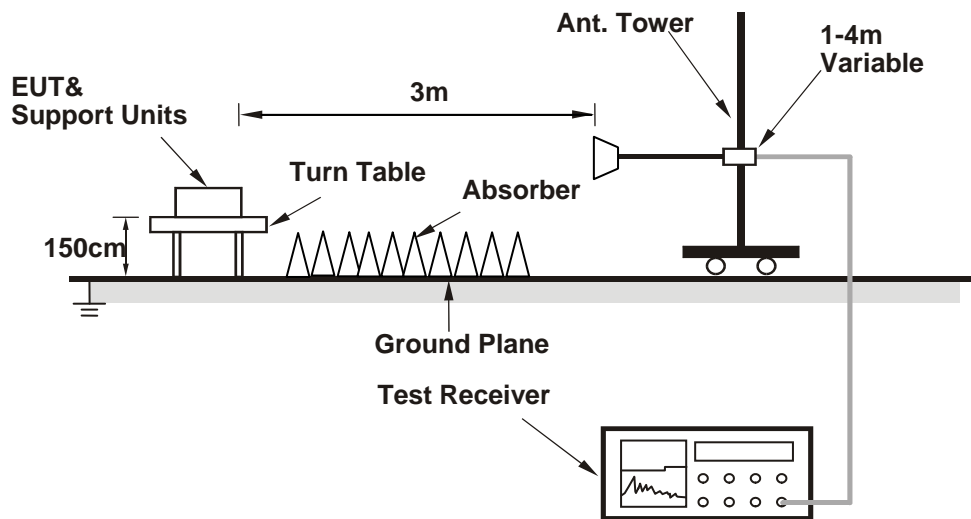

For the actual test configuration, please refer to the attached file (Test Setup Photo).

4.1.6 EUT Operating Conditions

- a. Set the EUT under transmission condition continuously at specific channel frequency.

4.1.7 Test Results

Above 1GHz data:

802.11a

CHANNEL	TX Channel 36	DETECTOR	Peak (PK)
FREQUENCY RANGE	1GHz ~ 40GHz	FUNCTION	Average (AV)

ANTENNA POLARITY & TEST DISTANCE: HORIZONTAL AT 3 M								
NO.	FREQ. (MHz)	EMISSION LEVEL (dBuV/m)	LIMIT (dBuV/m)	MARGIN (dB)	ANTENNA HEIGHT (m)	TABLE ANGLE (Degree)	RAW VALUE (dBuV)	CORRECTION FACTOR (dB/m)
1	5150.00	72.3 PK	74.0	-1.7	1.22 H	174	68.4	3.9
2	5150.00	52.9 AV	54.0	-1.1	1.22 H	174	49.0	3.9
3	*5180.00	105.6 PK			1.45 H	199	66.0	39.6
4	*5180.00	95.6 AV			1.45 H	199	56.0	39.6
5	#10360.00	59.0 PK	74.0	-15.0	1.46 H	128	43.2	15.8
6	#10360.00	45.8 AV	54.0	-8.2	1.46 H	128	30.0	15.8
ANTENNA POLARITY & TEST DISTANCE: VERTICAL AT 3 M								
NO.	FREQ. (MHz)	EMISSION LEVEL (dBuV/m)	LIMIT (dBuV/m)	MARGIN (dB)	ANTENNA HEIGHT (m)	TABLE ANGLE (Degree)	RAW VALUE (dBuV)	CORRECTION FACTOR (dB/m)
1	5150.00	63.4 PK	74.0	-10.6	1.43 V	177	59.5	3.9
2	5150.00	46.3 AV	54.0	-7.7	1.43 V	177	42.4	3.9
3	*5180.00	100.3 PK			1.24 V	197	60.7	39.6
4	*5180.00	90.6 AV			1.24 V	197	51.0	39.6
5	#10360.00	58.3 PK	74.0	-15.7	3.13 V	142	42.5	15.8
6	#10360.00	46.0 AV	54.0	-8.0	3.13 V	142	30.2	15.8

Remarks:

1. Emission Level(dBuV/m) = Raw Value(dBuV) + Correction Factor(dB/m)
2. Correction Factor(dB/m) = Antenna Factor(dB/m) + Cable Factor(dB) – Pre-Amplifier Factor(dB)
3. The other emission levels were very low against the limit.
4. Margin value = Emission Level – Limit value
5. " * ": Fundamental frequency.
6. " # ": The radiated frequency is out of the restricted band.

CHANNEL	TX Channel 40	DETECTOR FUNCTION	Peak (PK)
FREQUENCY RANGE	1GHz ~ 40GHz		Average (AV)

ANTENNA POLARITY & TEST DISTANCE: HORIZONTAL AT 3 M								
NO.	FREQ. (MHz)	EMISSION LEVEL (dBuV/m)	LIMIT (dBuV/m)	MARGIN (dB)	ANTENNA HEIGHT (m)	TABLE ANGLE (Degree)	RAW VALUE (dBuV)	CORRECTION FACTOR (dB/m)
1	*5200.00	104.3 PK			1.41 H	200	64.7	39.6
2	*5200.00	94.1 AV			1.41 H	200	54.5	39.6
3	#10400.00	59.2 PK	74.0	-14.8	1.96 H	150	43.3	15.9
4	#10400.00	45.7 AV	54.0	-8.3	1.96 H	150	29.8	15.9
ANTENNA POLARITY & TEST DISTANCE: VERTICAL AT 3 M								
NO.	FREQ. (MHz)	EMISSION LEVEL (dBuV/m)	LIMIT (dBuV/m)	MARGIN (dB)	ANTENNA HEIGHT (m)	TABLE ANGLE (Degree)	RAW VALUE (dBuV)	CORRECTION FACTOR (dB/m)
1	*5200.00	100.1 PK			1.27 V	197	60.5	39.6
2	*5200.00	89.9 AV			1.27 V	197	50.3	39.6
3	#10400.00	58.0 PK	74.0	-16.0	2.88 V	146	42.1	15.9
4	#10400.00	46.2 AV	54.0	-7.8	2.88 V	146	30.3	15.9

Remarks:

1. Emission Level(dBuV/m) = Raw Value(dBuV) + Correction Factor(dB/m)
2. Correction Factor(dB/m) = Antenna Factor(dB/m) + Cable Factor(dB) – Pre-Amplifier Factor(dB)
3. The other emission levels were very low against the limit.
4. Margin value = Emission Level – Limit value
5. " * ": Fundamental frequency.
6. " # ": The radiated frequency is out of the restricted band.

CHANNEL	TX Channel 48	DETECTOR FUNCTION	Peak (PK)
FREQUENCY RANGE	1GHz ~ 40GHz		Average (AV)

ANTENNA POLARITY & TEST DISTANCE: HORIZONTAL AT 3 M								
NO.	FREQ. (MHz)	EMISSION LEVEL (dBuV/m)	LIMIT (dBuV/m)	MARGIN (dB)	ANTENNA HEIGHT (m)	TABLE ANGLE (Degree)	RAW VALUE (dBuV)	CORRECTION FACTOR (dB/m)
1	*5240.00	106.0 PK			1.14 H	173	66.6	39.4
2	*5240.00	95.6 AV			1.14 H	173	56.2	39.4
3	5350.00	56.2 PK	74.0	-17.8	1.44 H	189	52.2	4.0
4	5350.00	42.8 AV	54.0	-11.2	1.44 H	189	38.8	4.0
5	#10480.00	58.0 PK	74.0	-16.0	1.88 H	206	41.3	16.7
6	#10480.00	46.4 AV	54.0	-7.6	1.88 H	206	29.7	16.7

ANTENNA POLARITY & TEST DISTANCE: VERTICAL AT 3 M								
NO.	FREQ. (MHz)	EMISSION LEVEL (dBuV/m)	LIMIT (dBuV/m)	MARGIN (dB)	ANTENNA HEIGHT (m)	TABLE ANGLE (Degree)	RAW VALUE (dBuV)	CORRECTION FACTOR (dB/m)
1	*5240.00	99.6 PK			1.48 V	196	60.2	39.4
2	*5240.00	89.6 AV			1.48 V	196	50.2	39.4
3	5350.00	45.9 PK	74.0	-28.1	1.33 V	172	41.9	4.0
4	5350.00	42.9 AV	54.0	-11.1	1.33 V	172	38.9	4.0
5	#10480.00	58.6 PK	74.0	-15.4	2.84 V	156	41.9	16.7
6	#10480.00	47.1 AV	54.0	-6.9	2.84 V	156	30.4	16.7

Remarks:

1. Emission Level(dBuV/m) = Raw Value(dBuV) + Correction Factor(dB/m)
2. Correction Factor(dB/m) = Antenna Factor(dB/m) + Cable Factor(dB) – Pre-Amplifier Factor(dB)
3. The other emission levels were very low against the limit.
4. Margin value = Emission Level – Limit value
5. " * ": Fundamental frequency.
6. " # ": The radiated frequency is out of the restricted band.

CHANNEL	TX Channel 149	DETECTOR FUNCTION	Peak (PK)
FREQUENCY RANGE	1GHz ~ 40GHz		Average (AV)

ANTENNA POLARITY & TEST DISTANCE: HORIZONTAL AT 3 M								
NO.	FREQ. (MHz)	EMISSION LEVEL (dBuV/m)	LIMIT (dBuV/m)	MARGIN (dB)	ANTENNA HEIGHT (m)	TABLE ANGLE (Degree)	RAW VALUE (dBuV)	CORRECTION FACTOR (dB/m)
1	#5645.60	55.3 PK	68.2	-12.9	1.52 H	101	50.7	4.6
2	*5745.00	101.8 PK			1.52 H	101	61.7	40.1
3	*5745.00	91.5 AV			1.52 H	101	51.4	40.1
4	#5964.80	56.6 PK	68.2	-11.6	1.52 H	101	51.4	5.2
5	11490.00	60.8 PK	74.0	-13.2	1.65 H	216	43.2	17.6
6	11490.00	48.2 AV	74.0	-25.8	1.65 H	216	30.6	17.6

ANTENNA POLARITY & TEST DISTANCE: VERTICAL AT 3 M								
NO.	FREQ. (MHz)	EMISSION LEVEL (dBuV/m)	LIMIT (dBuV/m)	MARGIN (dB)	ANTENNA HEIGHT (m)	TABLE ANGLE (Degree)	RAW VALUE (dBuV)	CORRECTION FACTOR (dB/m)
1	#5628.80	56.8 PK	68.2	-11.4	1.51 V	90	52.3	4.5
2	*5745.00	94.7 PK			1.51 V	90	54.6	40.1
3	*5745.00	84.5 AV			1.51 V	90	44.4	40.1
4	#5939.20	58.3 PK	68.2	-9.9	1.51 V	90	53.2	5.1
5	11490.00	60.1 PK	74.0	-13.9	1.49 V	168	42.5	17.6
6	11490.00	49.0 AV	54.0	-5.0	1.49 V	168	31.4	17.6

Remarks:

1. Emission Level(dBuV/m) = Raw Value(dBuV) + Correction Factor(dB/m)
2. Correction Factor(dB/m) = Antenna Factor(dB/m) + Cable Factor(dB) – Pre-Amplifier Factor(dB)
3. The other emission levels were very low against the limit.
4. Margin value = Emission Level – Limit value
5. " * ": Fundamental frequency.
6. " # ": The radiated frequency is out of the restricted band.

CHANNEL	TX Channel 157	DETECTOR FUNCTION	Peak (PK)
FREQUENCY RANGE	1GHz ~ 40GHz		Average (AV)

ANTENNA POLARITY & TEST DISTANCE: HORIZONTAL AT 3 M								
NO.	FREQ. (MHz)	EMISSION LEVEL (dBuV/m)	LIMIT (dBuV/m)	MARGIN (dB)	ANTENNA HEIGHT (m)	TABLE ANGLE (Degree)	RAW VALUE (dBuV)	CORRECTION FACTOR (dB/m)
1	#5648.00	56.8 PK	68.2	-11.4	2.71 H	98	52.2	4.6
2	*5785.00	100.3 PK			2.71 H	98	60.0	40.3
3	*5785.00	90.2 AV			2.71 H	98	49.9	40.3
4	#5965.60	58.0 PK	68.2	-10.2	2.71 H	98	52.8	5.2
5	11570.00	60.4 PK	74.0	-13.6	1.68 H	219	42.5	17.9
6	11570.00	48.1 AV	54.0	-5.9	1.68 H	219	30.2	17.9

ANTENNA POLARITY & TEST DISTANCE: VERTICAL AT 3 M								
NO.	FREQ. (MHz)	EMISSION LEVEL (dBuV/m)	LIMIT (dBuV/m)	MARGIN (dB)	ANTENNA HEIGHT (m)	TABLE ANGLE (Degree)	RAW VALUE (dBuV)	CORRECTION FACTOR (dB/m)
1	#5624.00	56.4 PK	68.2	-11.8	1.68 V	92	51.9	4.5
2	*5785.00	94.5 PK			1.68 V	92	54.2	40.3
3	*5785.00	84.4 AV			1.68 V	92	44.1	40.3
4	#5951.20	57.8 PK	68.2	-10.4	1.68 V	92	52.6	5.2
5	11570.00	59.7 PK	74.0	-14.3	1.63 V	194	41.8	17.9
6	11570.00	49.0 AV	54.0	-5.0	1.63 V	194	31.1	17.9

Remarks:

1. Emission Level(dBuV/m) = Raw Value(dBuV) + Correction Factor(dB/m)
2. Correction Factor(dB/m) = Antenna Factor(dB/m) + Cable Factor(dB) – Pre-Amplifier Factor(dB)
3. The other emission levels were very low against the limit.
4. Margin value = Emission Level – Limit value
5. " * ": Fundamental frequency.
6. " # ": The radiated frequency is out of the restricted band.

CHANNEL	TX Channel 165	DETECTOR FUNCTION	Peak (PK)
FREQUENCY RANGE	1GHz ~ 40GHz		Average (AV)

ANTENNA POLARITY & TEST DISTANCE: HORIZONTAL AT 3 M								
NO.	FREQ. (MHz)	EMISSION LEVEL (dBuV/m)	LIMIT (dBuV/m)	MARGIN (dB)	ANTENNA HEIGHT (m)	TABLE ANGLE (Degree)	RAW VALUE (dBuV)	CORRECTION FACTOR (dB/m)
1	#5620.00	56.5 PK	68.2	-11.7	2.71 H	98	52.0	4.5
2	*5825.00	101.0 PK			2.71 H	98	60.5	40.5
3	*5825.00	90.6 AV			2.71 H	98	50.1	40.5
4	#5932.00	58.0 PK	68.2	-10.2	2.71 H	98	52.8	5.2
5	11650.00	60.3 PK	74.0	-13.7	2.26 H	194	42.8	17.5
6	11650.00	47.5 AV	54.0	-6.5	2.26 H	194	30.0	17.5

ANTENNA POLARITY & TEST DISTANCE: VERTICAL AT 3 M								
NO.	FREQ. (MHz)	EMISSION LEVEL (dBuV/m)	LIMIT (dBuV/m)	MARGIN (dB)	ANTENNA HEIGHT (m)	TABLE ANGLE (Degree)	RAW VALUE (dBuV)	CORRECTION FACTOR (dB/m)
1	#5627.20	56.3 PK	68.2	-11.9	1.68 V	81	51.8	4.5
2	*5825.00	96.0 PK			1.68 V	81	55.5	40.5
3	*5825.00	85.9 AV			1.68 V	81	45.4	40.5
4	#5970.40	57.9 PK	68.2	-10.3	1.68 V	81	52.6	5.3
5	11650.00	60.1 PK	74.0	-13.9	1.66 V	192	42.6	17.5
6	11650.00	48.8 AV	54.0	-5.2	1.66 V	192	31.3	17.5

Remarks:

1. Emission Level(dBuV/m) = Raw Value(dBuV) + Correction Factor(dB/m)
2. Correction Factor(dB/m) = Antenna Factor(dB/m) + Cable Factor(dB) – Pre-Amplifier Factor(dB)
3. The other emission levels were very low against the limit.
4. Margin value = Emission Level – Limit value
5. " * ": Fundamental frequency.
6. " # ": The radiated frequency is out of the restricted band.

802.11n (HT20)

CHANNEL	TX Channel 36	DETECTOR	Peak (PK)
FREQUENCY RANGE	1GHz ~ 40GHz	FUNCTION	Average (AV)

ANTENNA POLARITY & TEST DISTANCE: HORIZONTAL AT 3 M

NO.	FREQ. (MHz)	EMISSION LEVEL (dBuV/m)	LIMIT (dBuV/m)	MARGIN (dB)	ANTENNA HEIGHT (m)	TABLE ANGLE (Degree)	RAW VALUE (dBuV)	CORRECTION FACTOR (dB/m)
1	5150.00	72.0 PK	74.0	-2.0	1.18 H	174	68.1	3.9
2	5150.00	52.3 AV	54.0	-1.7	1.18 H	174	48.4	3.9
3	*5180.00	105.2 PK			1.19 H	173	65.6	39.6
4	*5180.00	94.7 AV			1.19 H	173	55.1	39.6
5	#10360.00	58.0 PK	74.0	-16.0	2.01 H	178	42.2	15.8
6	#10360.00	45.7 AV	54.0	-8.3	2.01 H	178	29.9	15.8

ANTENNA POLARITY & TEST DISTANCE: VERTICAL AT 3 M

NO.	FREQ. (MHz)	EMISSION LEVEL (dBuV/m)	LIMIT (dBuV/m)	MARGIN (dB)	ANTENNA HEIGHT (m)	TABLE ANGLE (Degree)	RAW VALUE (dBuV)	CORRECTION FACTOR (dB/m)
1	5150.00	62.1 PK	74.0	-11.9	1.09 V	150	58.2	3.9
2	5150.00	46.5 AV	54.0	-7.5	1.09 V	150	42.6	3.9
3	*5180.00	99.5 PK			1.09 V	196	59.9	39.6
4	*5180.00	88.9 AV			1.09 V	196	49.3	39.6
5	#10360.00	58.0 PK	74.0	-16.0	2.74 V	186	42.2	15.8
6	#10360.00	46.1 AV	54.0	-7.9	2.74 V	186	30.3	15.8

Remarks:

1. Emission Level(dBuV/m) = Raw Value(dBuV) + Correction Factor(dB/m)
2. Correction Factor(dB/m) = Antenna Factor(dB/m) + Cable Factor(dB) – Pre-Amplifier Factor(dB)
3. The other emission levels were very low against the limit.
4. Margin value = Emission Level – Limit value
5. " * ": Fundamental frequency.
6. " # ": The radiated frequency is out of the restricted band.

CHANNEL	TX Channel 40	DETECTOR FUNCTION	Peak (PK)
FREQUENCY RANGE	1GHz ~ 40GHz		Average (AV)

ANTENNA POLARITY & TEST DISTANCE: HORIZONTAL AT 3 M								
NO.	FREQ. (MHz)	EMISSION LEVEL (dBuV/m)	LIMIT (dBuV/m)	MARGIN (dB)	ANTENNA HEIGHT (m)	TABLE ANGLE (Degree)	RAW VALUE (dBuV)	CORRECTION FACTOR (dB/m)
1	*5200.00	106.8 PK			1.11 H	171	67.2	39.6
2	*5200.00	96.2 AV			1.11 H	171	56.6	39.6
3	#10400.00	57.7 PK	74.0	-16.3	1.98 H	166	41.8	15.9
4	#10400.00	45.5 AV	54.0	-8.5	1.98 H	166	29.6	15.9
ANTENNA POLARITY & TEST DISTANCE: VERTICAL AT 3 M								
NO.	FREQ. (MHz)	EMISSION LEVEL (dBuV/m)	LIMIT (dBuV/m)	MARGIN (dB)	ANTENNA HEIGHT (m)	TABLE ANGLE (Degree)	RAW VALUE (dBuV)	CORRECTION FACTOR (dB/m)
1	*5200.00	99.7 PK			1.07 V	151	60.1	39.6
2	*5200.00	90.0 AV			1.07 V	151	50.4	39.6
3	#10400.00	58.2 PK	74.0	-15.8	2.76 V	184	42.3	15.9
4	#10400.00	46.4 AV	54.0	-7.6	2.76 V	184	30.5	15.9

Remarks:

1. Emission Level(dBuV/m) = Raw Value(dBuV) + Correction Factor(dB/m)
2. Correction Factor(dB/m) = Antenna Factor(dB/m) + Cable Factor(dB) – Pre-Amplifier Factor(dB)
3. The other emission levels were very low against the limit.
4. Margin value = Emission Level – Limit value
5. " * ": Fundamental frequency.
6. " # ": The radiated frequency is out of the restricted band.

CHANNEL	TX Channel 48	DETECTOR FUNCTION	Peak (PK)
FREQUENCY RANGE	1GHz ~ 40GHz		Average (AV)

ANTENNA POLARITY & TEST DISTANCE: HORIZONTAL AT 3 M								
NO.	FREQ. (MHz)	EMISSION LEVEL (dBuV/m)	LIMIT (dBuV/m)	MARGIN (dB)	ANTENNA HEIGHT (m)	TABLE ANGLE (Degree)	RAW VALUE (dBuV)	CORRECTION FACTOR (dB/m)
1	*5240.00	106.1 PK			1.07 H	171	66.7	39.4
2	*5240.00	95.5 AV			1.07 H	171	56.1	39.4
3	5350.00	56.6 PK	74.0	-17.4	1.21 H	182	52.6	4.0
4	5350.00	43.1 AV	54.0	-10.9	1.21 H	182	39.1	4.0
5	#10480.00	58.6 PK	74.0	-15.4	1.77 H	165	41.9	16.7
6	#10480.00	46.1 AV	54.0	-7.9	1.77 H	165	29.4	16.7

ANTENNA POLARITY & TEST DISTANCE: VERTICAL AT 3 M								
NO.	FREQ. (MHz)	EMISSION LEVEL (dBuV/m)	LIMIT (dBuV/m)	MARGIN (dB)	ANTENNA HEIGHT (m)	TABLE ANGLE (Degree)	RAW VALUE (dBuV)	CORRECTION FACTOR (dB/m)
1	*5240.00	99.3 PK			1.08 V	151	59.9	39.4
2	*5240.00	89.1 AV			1.08 V	151	49.7	39.4
3	5350.00	56.4 PK	74.0	-17.6	1.22 V	174	52.4	4.0
4	5350.00	42.9 AV	54.0	-11.1	1.22 V	174	38.9	4.0
5	#10480.00	58.8 PK	74.0	-15.2	2.77 V	169	42.1	16.7
6	#10480.00	47.0 AV	54.0	-7.0	2.77 V	169	30.3	16.7

Remarks:

1. Emission Level(dBuV/m) = Raw Value(dBuV) + Correction Factor(dB/m)
2. Correction Factor(dB/m) = Antenna Factor(dB/m) + Cable Factor(dB) – Pre-Amplifier Factor(dB)
3. The other emission levels were very low against the limit.
4. Margin value = Emission Level – Limit value
5. " * ": Fundamental frequency.
6. " # ": The radiated frequency is out of the restricted band.

CHANNEL	TX Channel 149	DETECTOR FUNCTION	Peak (PK)
FREQUENCY RANGE	1GHz ~ 40GHz		Average (AV)

ANTENNA POLARITY & TEST DISTANCE: HORIZONTAL AT 3 M								
NO.	FREQ. (MHz)	EMISSION LEVEL (dBuV/m)	LIMIT (dBuV/m)	MARGIN (dB)	ANTENNA HEIGHT (m)	TABLE ANGLE (Degree)	RAW VALUE (dBuV)	CORRECTION FACTOR (dB/m)
1	#5648.80	56.6 PK	68.2	-11.6	1.44 H	108	52.0	4.6
2	*5745.00	100.7 PK			1.44 H	108	60.6	40.1
3	*5745.00	90.3 AV			1.44 H	108	50.2	40.1
4	#5956.00	57.7 PK	68.2	-10.5	1.44 H	108	52.5	5.2
5	11490.00	60.2 PK	74.0	-13.8	1.37 H	237	42.6	17.6
6	11490.00	47.5 AV	54.0	-6.5	1.37 H	237	29.9	17.6

ANTENNA POLARITY & TEST DISTANCE: VERTICAL AT 3 M								
NO.	FREQ. (MHz)	EMISSION LEVEL (dBuV/m)	LIMIT (dBuV/m)	MARGIN (dB)	ANTENNA HEIGHT (m)	TABLE ANGLE (Degree)	RAW VALUE (dBuV)	CORRECTION FACTOR (dB/m)
1	#5645.60	56.2 PK	68.2	-12.0	1.81 V	80	51.6	4.6
2	*5745.00	97.1 PK			1.81 V	80	57.0	40.1
3	*5745.00	86.9 AV			1.81 V	80	46.8	40.1
4	#5967.20	57.4 PK	68.2	-10.8	1.81 V	80	52.1	5.3
5	11490.00	59.8 PK	74.0	-14.2	1.71 V	196	42.2	17.6
6	11490.00	48.6 AV	54.0	-5.4	1.71 V	196	31.0	17.6

Remarks:

1. Emission Level(dBuV/m) = Raw Value(dBuV) + Correction Factor(dB/m)
2. Correction Factor(dB/m) = Antenna Factor(dB/m) + Cable Factor(dB) – Pre-Amplifier Factor(dB)
3. The other emission levels were very low against the limit.
4. Margin value = Emission Level – Limit value
5. " * ": Fundamental frequency.
6. " # ": The radiated frequency is out of the restricted band.

CHANNEL	TX Channel 157	DETECTOR FUNCTION	Peak (PK)
FREQUENCY RANGE	1GHz ~ 40GHz		Average (AV)

ANTENNA POLARITY & TEST DISTANCE: HORIZONTAL AT 3 M

NO.	FREQ. (MHz)	EMISSION LEVEL (dBuV/m)	LIMIT (dBuV/m)	MARGIN (dB)	ANTENNA HEIGHT (m)	TABLE ANGLE (Degree)	RAW VALUE (dBuV)	CORRECTION FACTOR (dB/m)
1	#5648.80	55.2 PK	68.2	-13.0	1.46 H	111	50.6	4.6
2	*5785.00	100.2 PK			1.46 H	111	59.9	40.3
3	*5785.00	89.8 AV			1.46 H	111	49.5	40.3
4	#5955.20	56.6 PK	68.2	-11.6	1.46 H	111	51.4	5.2
5	11570.00	61.1 PK	74.0	-12.9	1.63 H	264	43.2	17.9
6	11570.00	48.0 AV	54.0	-6.0	1.63 H	264	30.1	17.9

ANTENNA POLARITY & TEST DISTANCE: VERTICAL AT 3 M

NO.	FREQ. (MHz)	EMISSION LEVEL (dBuV/m)	LIMIT (dBuV/m)	MARGIN (dB)	ANTENNA HEIGHT (m)	TABLE ANGLE (Degree)	RAW VALUE (dBuV)	CORRECTION FACTOR (dB/m)
1	#5632.80	56.1 PK	68.2	-12.1	1.79 V	81	51.6	4.5
2	*5785.00	96.5 PK			1.79 V	81	56.2	40.3
3	*5785.00	86.0 AV			1.79 V	81	45.7	40.3
4	#5955.20	57.3 PK	68.2	-10.9	1.79 V	81	52.1	5.2
5	11570.00	60.8 PK	74.0	-13.2	1.83 V	201	42.9	17.9
6	11570.00	49.6 AV	54.0	-4.4	1.83 V	201	31.7	17.9

Remarks:

1. Emission Level(dBuV/m) = Raw Value(dBuV) + Correction Factor(dB/m)
2. Correction Factor(dB/m) = Antenna Factor(dB/m) + Cable Factor(dB) – Pre-Amplifier Factor(dB)
3. The other emission levels were very low against the limit.
4. Margin value = Emission Level – Limit value
5. " * ": Fundamental frequency.
6. " # ": The radiated frequency is out of the restricted band.

CHANNEL	TX Channel 165	DETECTOR FUNCTION	Peak (PK)
FREQUENCY RANGE	1GHz ~ 40GHz		Average (AV)

ANTENNA POLARITY & TEST DISTANCE: HORIZONTAL AT 3 M

NO.	FREQ. (MHz)	EMISSION LEVEL (dBuV/m)	LIMIT (dBuV/m)	MARGIN (dB)	ANTENNA HEIGHT (m)	TABLE ANGLE (Degree)	RAW VALUE (dBuV)	CORRECTION FACTOR (dB/m)
1	#5612.00	56.7 PK	68.2	-11.5	1.42 H	110	52.2	4.5
2	*5825.00	100.2 PK			1.42 H	110	59.7	40.5
3	*5825.00	89.5 AV			1.42 H	110	49.0	40.5
4	#5962.40	57.6 PK	68.2	-10.6	1.42 H	110	52.4	5.2
5	11650.00	60.1 PK	74.0	-13.9	2.13 H	247	42.6	17.5
6	11650.00	47.7 AV	54.0	-6.3	2.13 H	247	30.2	17.5

ANTENNA POLARITY & TEST DISTANCE: VERTICAL AT 3 M

NO.	FREQ. (MHz)	EMISSION LEVEL (dBuV/m)	LIMIT (dBuV/m)	MARGIN (dB)	ANTENNA HEIGHT (m)	TABLE ANGLE (Degree)	RAW VALUE (dBuV)	CORRECTION FACTOR (dB/m)
1	#5613.60	56.0 PK	68.2	-12.2	1.82 V	82	51.5	4.5
2	*5825.00	96.5 PK			1.82 V	82	56.0	40.5
3	*5825.00	85.9 AV			1.82 V	82	45.4	40.5
4	#5960.80	57.0 PK	68.2	-11.2	1.82 V	82	51.8	5.2
5	11650.00	60.6 PK	74.0	-13.4	2.23 V	161	43.1	17.5
6	11650.00	49.2 AV	54.0	-4.8	2.23 V	161	31.7	17.5

Remarks:

1. Emission Level(dBuV/m) = Raw Value(dBuV) + Correction Factor(dB/m)
2. Correction Factor(dB/m) = Antenna Factor(dB/m) + Cable Factor(dB) – Pre-Amplifier Factor(dB)
3. The other emission levels were very low against the limit.
4. Margin value = Emission Level – Limit value
5. " * ": Fundamental frequency.
6. " # ": The radiated frequency is out of the restricted band.

802.11n (HT40)

CHANNEL	TX Channel 38	DETECTOR	Peak (PK)
FREQUENCY RANGE	1GHz ~ 40GHz	FUNCTION	Average (AV)

ANTENNA POLARITY & TEST DISTANCE: HORIZONTAL AT 3 M								
NO.	FREQ. (MHz)	EMISSION LEVEL (dBuV/m)	LIMIT (dBuV/m)	MARGIN (dB)	ANTENNA HEIGHT (m)	TABLE ANGLE (Degree)	RAW VALUE (dBuV)	CORRECTION FACTOR (dB/m)
1	5150.00	70.0 PK	74.0	-4.0	1.52 H	185	66.1	3.9
2	5150.00	52.3 AV	54.0	-1.7	1.52 H	185	48.4	3.9
3	*5190.00	99.9 PK			1.56 H	183	60.3	39.6
4	*5190.00	89.1 AV			1.56 H	183	49.5	39.6
5	#10380.00	57.6 PK	74.0	-16.4	1.29 H	103	41.7	15.9
6	#10380.00	45.5 AV	54.0	-8.5	1.29 H	103	29.6	15.9
ANTENNA POLARITY & TEST DISTANCE: VERTICAL AT 3 M								
NO.	FREQ. (MHz)	EMISSION LEVEL (dBuV/m)	LIMIT (dBuV/m)	MARGIN (dB)	ANTENNA HEIGHT (m)	TABLE ANGLE (Degree)	RAW VALUE (dBuV)	CORRECTION FACTOR (dB/m)
1	5150.00	66.4 PK	74.0	-7.6	1.39 V	156	62.5	3.9
2	5150.00	49.2 AV	54.0	-4.8	1.39 V	156	45.3	3.9
3	*5190.00	96.7 PK			1.05 V	189	57.1	39.6
4	*5190.00	86.2 AV			1.05 V	189	46.6	39.6
5	#10380.00	58.3 PK	74.0	-15.7	3.17 V	284	42.4	15.9
6	#10380.00	46.7 AV	54.0	-7.3	3.17 V	284	30.8	15.9

Remarks:

1. Emission Level(dBuV/m) = Raw Value(dBuV) + Correction Factor(dB/m)
2. Correction Factor(dB/m) = Antenna Factor(dB/m) + Cable Factor(dB) – Pre-Amplifier Factor(dB)
3. The other emission levels were very low against the limit.
4. Margin value = Emission Level – Limit value
5. " * ": Fundamental frequency.
6. " # ": The radiated frequency is out of the restricted band.

CHANNEL	TX Channel 46	DETECTOR FUNCTION	Peak (PK)
FREQUENCY RANGE	1GHz ~ 40GHz		Average (AV)

ANTENNA POLARITY & TEST DISTANCE: HORIZONTAL AT 3 M

NO.	FREQ. (MHz)	EMISSION LEVEL (dBuV/m)	LIMIT (dBuV/m)	MARGIN (dB)	ANTENNA HEIGHT (m)	TABLE ANGLE (Degree)	RAW VALUE (dBuV)	CORRECTION FACTOR (dB/m)
1	*5230.00	103.9 PK			1.15 H	163	64.5	39.4
2	*5230.00	93.5 AV			1.15 H	163	54.1	39.4
3	5350.00	55.4 PK	74.0	-18.6	1.49 H	178	51.4	4.0
4	5350.00	42.6 AV	54.0	-11.4	1.49 H	178	38.6	4.0
5	#10460.00	59.3 PK	74.0	-14.7	1.32 H	166	42.9	16.4
6	#10460.00	46.6 AV	54.0	-7.4	1.32 H	166	30.2	16.4

ANTENNA POLARITY & TEST DISTANCE: VERTICAL AT 3 M

NO.	FREQ. (MHz)	EMISSION LEVEL (dBuV/m)	LIMIT (dBuV/m)	MARGIN (dB)	ANTENNA HEIGHT (m)	TABLE ANGLE (Degree)	RAW VALUE (dBuV)	CORRECTION FACTOR (dB/m)
1	*5230.00	99.4 PK			1.00 V	190	60.0	39.4
2	*5230.00	88.8 AV			1.00 V	190	49.4	39.4
3	5350.00	55.6 PK	74.0	-18.4	1.22 V	157	51.6	4.0
4	5350.00	42.5 AV	54.0	-11.5	1.22 V	157	38.5	4.0
5	#10460.00	59.8 PK	74.0	-14.2	2.87 V	255	43.4	16.4
6	#10460.00	48.0 AV	54.0	-6.0	2.87 V	255	31.6	16.4

Remarks:

1. Emission Level(dBuV/m) = Raw Value(dBuV) + Correction Factor(dB/m)
2. Correction Factor(dB/m) = Antenna Factor(dB/m) + Cable Factor(dB) – Pre-Amplifier Factor(dB)
3. The other emission levels were very low against the limit.
4. Margin value = Emission Level – Limit value
5. " * ": Fundamental frequency.
6. " # ": The radiated frequency is out of the restricted band.

CHANNEL	TX Channel 151	DETECTOR FUNCTION	Peak (PK)
FREQUENCY RANGE	1GHz ~ 40GHz		Average (AV)

ANTENNA POLARITY & TEST DISTANCE: HORIZONTAL AT 3 M								
NO.	FREQ. (MHz)	EMISSION LEVEL (dBuV/m)	LIMIT (dBuV/m)	MARGIN (dB)	ANTENNA HEIGHT (m)	TABLE ANGLE (Degree)	RAW VALUE (dBuV)	CORRECTION FACTOR (dB/m)
1	#5625.60	56.9 PK	68.2	-11.3	2.74 H	99	52.4	4.5
2	*5755.00	99.4 PK			2.74 H	99	59.3	40.1
3	*5755.00	89.0 AV			2.74 H	99	48.9	40.1
4	#5990.40	57.4 PK	68.2	-10.8	2.74 H	99	52.1	5.3
5	11510.00	60.3 PK	74.0	-13.7	2.83 H	169	42.7	17.6
6	11510.00	48.7 AV	54.0	-5.3	2.83 H	169	31.1	17.6

ANTENNA POLARITY & TEST DISTANCE: VERTICAL AT 3 M								
NO.	FREQ. (MHz)	EMISSION LEVEL (dBuV/m)	LIMIT (dBuV/m)	MARGIN (dB)	ANTENNA HEIGHT (m)	TABLE ANGLE (Degree)	RAW VALUE (dBuV)	CORRECTION FACTOR (dB/m)
1	#5640.00	56.8 PK	68.2	-11.4	1.51 V	96	52.3	4.5
2	*5755.00	93.9 PK			1.51 V	96	53.8	40.1
3	*5755.00	83.1 AV			1.51 V	96	43.0	40.1
4	#5958.40	58.0 PK	68.2	-10.2	1.51 V	96	52.8	5.2
5	11510.00	60.2 PK	74.0	-13.8	1.48 V	175	42.6	17.6
6	11510.00	49.2 AV	54.0	-4.8	1.48 V	175	31.6	17.6

Remarks:

1. Emission Level(dBuV/m) = Raw Value(dBuV) + Correction Factor(dB/m)
2. Correction Factor(dB/m) = Antenna Factor(dB/m) + Cable Factor(dB) – Pre-Amplifier Factor(dB)
3. The other emission levels were very low against the limit.
4. Margin value = Emission Level – Limit value
5. " * ": Fundamental frequency.
6. " # ": The radiated frequency is out of the restricted band.

CHANNEL	TX Channel 159	DETECTOR FUNCTION	Peak (PK)
FREQUENCY RANGE	1GHz ~ 40GHz		Average (AV)

ANTENNA POLARITY & TEST DISTANCE: HORIZONTAL AT 3 M								
NO.	FREQ. (MHz)	EMISSION LEVEL (dBuV/m)	LIMIT (dBuV/m)	MARGIN (dB)	ANTENNA HEIGHT (m)	TABLE ANGLE (Degree)	RAW VALUE (dBuV)	CORRECTION FACTOR (dB/m)
1	#5624.00	56.5 PK	68.2	-11.7	2.71 H	99	52.0	4.5
2	*5795.00	98.4 PK			2.71 H	99	58.1	40.3
3	*5795.00	87.8 AV			2.71 H	99	47.5	40.3
4	#5942.40	57.2 PK	68.2	-11.0	2.71 H	99	52.1	5.1
5	11590.00	60.6 PK	74.0	-13.4	2.82 H	193	42.7	17.9
6	11590.00	47.5 AV	54.0	-6.5	2.82 H	193	29.6	17.9

ANTENNA POLARITY & TEST DISTANCE: VERTICAL AT 3 M								
NO.	FREQ. (MHz)	EMISSION LEVEL (dBuV/m)	LIMIT (dBuV/m)	MARGIN (dB)	ANTENNA HEIGHT (m)	TABLE ANGLE (Degree)	RAW VALUE (dBuV)	CORRECTION FACTOR (dB/m)
1	#5632.00	56.4 PK	68.2	-11.8	1.51 V	98	51.9	4.5
2	*5795.00	93.5 PK			1.51 V	98	53.2	40.3
3	*5795.00	83.1 AV			1.51 V	98	42.8	40.3
4	#5958.40	58.8 PK	68.2	-9.4	1.51 V	98	53.6	5.2
5	11590.00	61.0 PK	74.0	-13.0	1.52 V	181	43.1	17.9
6	11590.00	48.4 AV	54.0	-5.6	1.52 V	181	30.5	17.9

Remarks:

1. Emission Level(dBuV/m) = Raw Value(dBuV) + Correction Factor(dB/m)
2. Correction Factor(dB/m) = Antenna Factor(dB/m) + Cable Factor(dB) – Pre-Amplifier Factor(dB)
3. The other emission levels were very low against the limit.
4. Margin value = Emission Level – Limit value
5. " * ": Fundamental frequency.
6. " # ": The radiated frequency is out of the restricted band.

802.11ac (VHT80)

CHANNEL	TX Channel 42	DETECTOR FUNCTION	Peak (PK)
FREQUENCY RANGE	1GHz ~ 40GHz		Average (AV)

ANTENNA POLARITY & TEST DISTANCE: HORIZONTAL AT 3 M

NO.	FREQ. (MHz)	EMISSION LEVEL (dBuV/m)	LIMIT (dBuV/m)	MARGIN (dB)	ANTENNA HEIGHT (m)	TABLE ANGLE (Degree)	RAW VALUE (dBuV)	CORRECTION FACTOR (dB/m)
1	5150.00	67.3 PK	74.0	-6.7	1.18 H	175	63.4	3.9
2	5150.00	52.5 AV	54.0	-1.5	1.18 H	175	48.6	3.9
3	*5210.00	95.7 PK			1.18 H	175	56.2	39.5
4	*5210.00	85.0 AV			1.18 H	175	45.5	39.5
5	5350.00	55.0 PK	74.0	-19.0	1.47 H	189	51.0	4.0
6	5350.00	42.5 AV	54.0	-11.5	1.47 H	189	38.5	4.0
7	#10420.00	56.6 PK	74.0	-17.4	1.56 H	148	40.6	16.0
8	#10420.00	44.9 AV	54.0	-9.1	1.56 H	148	28.9	16.0

ANTENNA POLARITY & TEST DISTANCE: VERTICAL AT 3 M

NO.	FREQ. (MHz)	EMISSION LEVEL (dBuV/m)	LIMIT (dBuV/m)	MARGIN (dB)	ANTENNA HEIGHT (m)	TABLE ANGLE (Degree)	RAW VALUE (dBuV)	CORRECTION FACTOR (dB/m)
1	5150.00	63.7 PK	74.0	-10.3	1.10 V	159	59.8	3.9
2	5150.00	48.2 AV	54.0	-5.8	1.10 V	159	44.3	3.9
3	*5210.00	90.3 PK			1.07 V	189	50.8	39.5
4	*5210.00	79.9 AV			1.07 V	189	40.4	39.5
5	5350.00	55.2 PK	74.0	-18.8	1.43 V	177	51.2	4.0
6	5350.00	42.4 AV	54.0	-11.6	1.43 V	177	38.4	4.0
7	#10420.00	56.8 PK	74.0	-17.2	2.71 V	212	40.8	16.0
8	#10420.00	44.8 AV	54.0	-9.2	2.71 V	212	28.8	16.0

Remarks:

1. Emission Level(dBuV/m) = Raw Value(dBuV) + Correction Factor(dB/m)
2. Correction Factor(dB/m) = Antenna Factor(dB/m) + Cable Factor(dB) – Pre-Amplifier Factor(dB)
3. The other emission levels were very low against the limit.
4. Margin value = Emission Level – Limit value
5. " * ": Fundamental frequency.
6. " # ": The radiated frequency is out of the restricted band.

CHANNEL	TX Channel 155	DETECTOR FUNCTION	Peak (PK)
FREQUENCY RANGE	1GHz ~ 40GHz		Average (AV)

ANTENNA POLARITY & TEST DISTANCE: HORIZONTAL AT 3 M

NO.	FREQ. (MHz)	EMISSION LEVEL (dBuV/m)	LIMIT (dBuV/m)	MARGIN (dB)	ANTENNA HEIGHT (m)	TABLE ANGLE (Degree)	RAW VALUE (dBuV)	CORRECTION FACTOR (dB/m)
1	#5647.20	61.7 PK	68.2	-6.5	2.75 H	99	57.1	4.6
2	#5650.00	63.2 PK	68.2	-5.0	2.38 H	104	58.6	4.6
3	*5775.00	96.9 PK			2.75 H	99	56.7	40.2
4	*5775.00	86.1 AV			2.75 H	99	45.9	40.2
5	#5925.00	59.2 PK	68.2	-9.0	2.33 H	121	54.0	5.2
6	#5928.80	58.3 PK	68.2	-9.9	2.75 H	99	53.1	5.2
7	11550.00	60.7 PK	74.0	-13.3	1.99 H	184	42.9	17.8
8	11550.00	47.2 AV	54.0	-6.8	1.99 H	184	29.4	17.8

ANTENNA POLARITY & TEST DISTANCE: VERTICAL AT 3 M

NO.	FREQ. (MHz)	EMISSION LEVEL (dBuV/m)	LIMIT (dBuV/m)	MARGIN (dB)	ANTENNA HEIGHT (m)	TABLE ANGLE (Degree)	RAW VALUE (dBuV)	CORRECTION FACTOR (dB/m)
1	#5649.60	58.0 PK	68.2	-10.2	1.52 V	97	53.4	4.6
2	#5650.00	59.6 PK	68.2	-8.6	1.59 V	108	55.0	4.6
3	*5775.00	91.6 PK			1.52 V	97	51.4	40.2
4	*5775.00	81.3 AV			1.52 V	97	41.1	40.2
5	#5925.00	57.3 PK	68.2	-10.9	1.44 V	117	52.1	5.2
6	#5930.40	57.8 PK	68.2	-10.4	1.52 V	97	52.6	5.2
7	11550.00	60.7 PK	74.0	-13.3	1.55 V	184	42.9	17.8
8	11550.00	48.5 AV	54.0	-5.5	1.55 V	184	30.7	17.8

Remarks:

1. Emission Level(dBuV/m) = Raw Value(dBuV) + Correction Factor(dB/m)
2. Correction Factor(dB/m) = Antenna Factor(dB/m) + Cable Factor(dB) – Pre-Amplifier Factor(dB)
3. The other emission levels were very low against the limit.
4. Margin value = Emission Level – Limit value
5. " * ": Fundamental frequency.
6. " # ": The radiated frequency is out of the restricted band.

Below 1GHz Worst-Case Data: 802.11a

CHANNEL	TX Channel 40	DETECTOR FUNCTION	Quasi-Peak (QP)
FREQUENCY RANGE	9kHz ~ 1GHz		

ANTENNA POLARITY & TEST DISTANCE: HORIZONTAL AT 3 M								
NO.	FREQ. (MHz)	EMISSION LEVEL (dBuV/m)	LIMIT (dBuV/m)	MARGIN (dB)	ANTENNA HEIGHT (m)	TABLE ANGLE (Degree)	RAW VALUE (dBuV)	CORRECTION FACTOR (dB/m)
1	30.00	34.3 QP	40.0	-5.7	1.01 H	9	50.4	-16.1
2	288.49	38.0 QP	46.0	-8.0	1.01 H	234	51.0	-13.0
3	374.04	39.4 QP	46.0	-6.6	1.01 H	104	51.0	-11.6
4	492.64	38.8 QP	46.0	-7.2	1.50 H	16	48.4	-9.6
5	535.42	34.6 QP	46.0	-11.4	1.50 H	147	43.7	-9.1
6	650.13	33.6 QP	46.0	-12.4	1.01 H	121	40.2	-6.6
ANTENNA POLARITY & TEST DISTANCE: VERTICAL AT 3 M								
NO.	FREQ. (MHz)	EMISSION LEVEL (dBuV/m)	LIMIT (dBuV/m)	MARGIN (dB)	ANTENNA HEIGHT (m)	TABLE ANGLE (Degree)	RAW VALUE (dBuV)	CORRECTION FACTOR (dB/m)
1	31.84	32.1 QP	40.0	-7.9	1.49 V	16	48.1	-16.0
2	288.49	35.8 QP	46.0	-10.2	1.99 V	18	48.8	-13.0
3	335.15	39.7 QP	46.0	-6.3	1.49 V	30	51.8	-12.1
4	374.04	42.1 QP	46.0	-3.9	1.49 V	124	53.7	-11.6
5	492.64	40.0 QP	46.0	-6.0	1.00 V	107	49.6	-9.6
6	624.85	32.9 QP	46.0	-13.1	1.49 V	170	39.7	-6.8

Remarks:

1. Emission Level(dBuV/m) = Raw Value(dBuV) + Correction Factor(dB/m)
2. Correction Factor(dB/m) = Antenna Factor(dB/m) + Cable Factor(dB) – Pre-Amplifier Factor(dB)
3. The other emission levels were very low against the limit.
4. Margin value = Emission Level – Limit value

4.2 Conducted Emission Measurement

4.2.1 Limits of Conducted Emission Measurement

Frequency (MHz)	Conducted Limit (dBuV)	
	Quasi-peak	Average
0.15 - 0.5	66 - 56	56 - 46
0.50 - 5.0	56	46
5.0 - 30.0	60	50

Note: 1. The lower limit shall apply at the transition frequencies.

2. The limit decreases in line with the logarithm of the frequency in the range of 0.15 to 0.50MHz.

4.2.2 Test Instruments

Description & Manufacturer	Model No.	Serial No.	Cal. Date	Cal. Due
Test Receiver ROHDE & SCHWARZ	ESCI	100613	Nov. 23, 2017	Nov. 22, 2018
RF signal cable (with 10dB PAD) Woken	5D-FB	Cable-cond1-01	Sep. 05, 2017	Sep. 04, 2018
LISN ROHDE & SCHWARZ (EUT)	ESH3-Z5	835239/001	Mar. 06, 2018	Mar. 05, 2019
LISN ROHDE & SCHWARZ (Peripheral)	ESH3-Z5	100311	Aug. 15, 2017	Aug. 14, 2018
Software ADT	BV ADT_Cond_ V7.3.7.3	NA	NA	NA

Note: 1. The calibration interval of the above test instruments is 12 months and the calibrations are traceable to NML/ROC and NIST/USA.

2. The test was performed in HwaYa Shielded Room 1.

3. The VCCI Site Registration No. is C-2040.

4.2.3 Test Procedures

- The EUT was placed 0.4 meters from the conducting wall of the shielded room with EUT being connected to the power mains through a line impedance stabilization network (LISN). Other support units were connected to the power mains through another LISN. The two LISNs provide 50 ohm/ 50uH of coupling impedance for the measuring instrument.
- Both lines of the power mains connected to the EUT were checked for maximum conducted interference.
- The frequency range from 150kHz to 30MHz was searched. Emission levels under (Limit - 20dB) was not recorded.

Note: The resolution bandwidth and video bandwidth of test receiver is 9kHz for quasi-peak detection (QP) and average detection (AV) at frequency 0.15MHz-30MHz.

4.2.4 Deviation from Test Standard

No deviation.

4.2.5 Test Setup

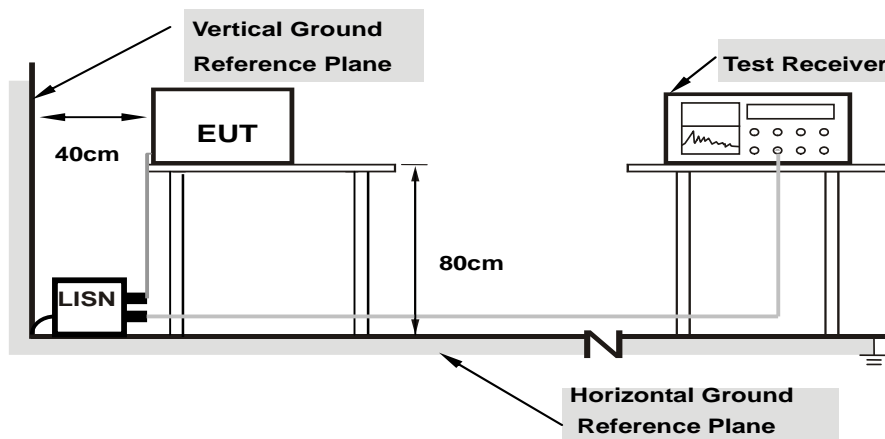

Note: 1.Support units were connected to second LISN.

For the actual test configuration, please refer to the attached file (Test Setup Photo).

4.2.6 EUT Operating Conditions

Same as 4.1.6.

4.2.7 Test Results

Worst-case data: 802.11a

Phase	Line (L)	Detector Function	Quasi-Peak (QP) / Average (AV)
-------	----------	-------------------	--------------------------------

No	Freq. [MHz]	Corr. Factor (dB)	Reading Value [dB (uV)]		Emission Level [dB (uV)]		Limit [dB (uV)]		Margin (dB)	
			Q.P.	AV.	Q.P.	AV.	Q.P.	AV.	Q.P.	AV.
1	0.16967	10.10	34.18	28.51	44.28	38.61	64.98	54.98	-20.70	-16.37
2	0.20084	10.10	31.22	24.94	41.32	35.04	63.58	53.58	-22.26	-18.54
3	0.40055	10.11	35.10	29.13	45.21	39.24	57.84	47.84	-12.63	-8.60
4	0.95561	10.13	24.45	17.10	34.58	27.23	56.00	46.00	-21.42	-18.77
5	3.25454	10.25	22.49	16.96	32.74	27.21	56.00	46.00	-23.26	-18.79
6	9.28767	10.59	23.90	18.45	34.49	29.04	60.00	50.00	-25.51	-20.96

Remarks:

1. Q.P. and AV. are abbreviations of quasi-peak and average individually.
2. The emission levels of other frequencies were very low against the limit.
3. Margin value = Emission level - Limit value
4. Correction factor = Insertion loss + Cable loss
5. Emission Level = Correction Factor + Reading Value.

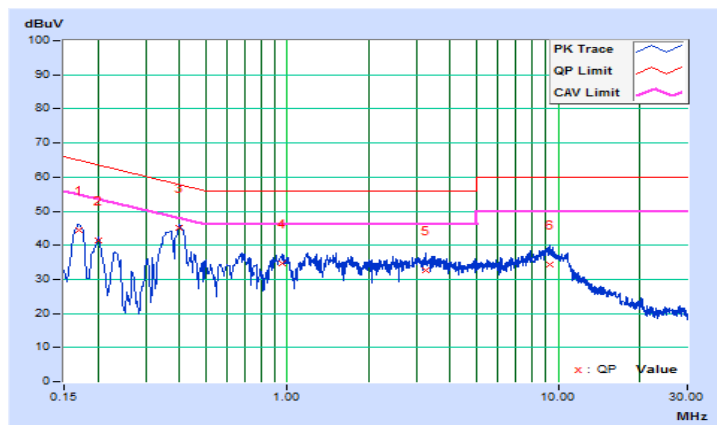

Phase	Neutral (N)	Detector Function	Quasi-Peak (QP) / Average (AV)
-------	-------------	-------------------	--------------------------------

No	Freq. [MHz]	Corr. Factor (dB)	Reading Value [dB (uV)]		Emission Level [dB (uV)]		Limit [dB (uV)]		Margin (dB)	
			Q.P.	AV.	Q.P.	AV.	Q.P.	AV.	Q.P.	AV.
			1	0.17192	10.09	35.36	27.94	45.45	38.03	64.87
2	0.20084	10.09	32.99	25.82	43.08	35.91	63.58	53.58	-20.50	-17.67
3	0.39635	10.11	35.19	27.18	45.30	37.29	57.93	47.93	-12.63	-10.64
4	0.69740	10.12	24.69	16.99	34.81	27.11	56.00	46.00	-21.19	-18.89
5	3.74329	10.26	21.42	14.57	31.68	24.83	56.00	46.00	-24.32	-21.17
6	10.78129	10.58	22.30	16.36	32.88	26.94	60.00	50.00	-27.12	-23.06

Remarks:

1. Q.P. and AV. are abbreviations of quasi-peak and average individually.
2. The emission levels of other frequencies were very low against the limit.
3. Margin value = Emission level - Limit value
4. Correction factor = Insertion loss + Cable loss
5. Emission Level = Correction Factor + Reading Value.

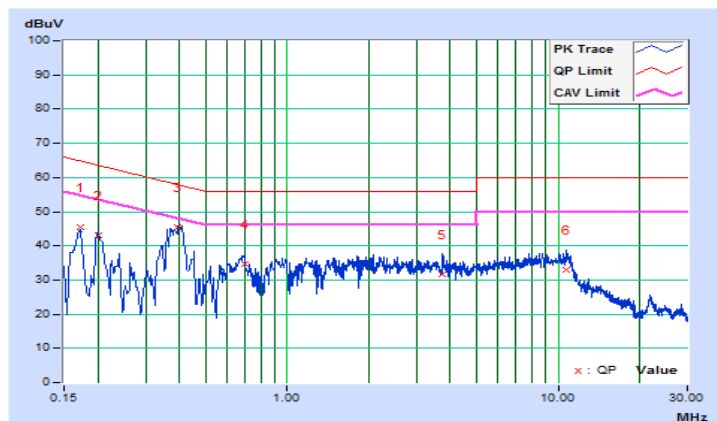

4.3 Transmit Power Measurement

4.3.1 Limits of Transmit Power Measurement

Operation Band	EUT Category		Limit
U-NII-1		Outdoor Access Point	1 Watt (30 dBm) (Max. e.i.r.p \leq 125mW(21 dBm) at any elevation angle above 30 degrees as measured from the horizon)
		Fixed point-to-point Access Point	1 Watt (30 dBm)
		Indoor Access Point	1 Watt (30 dBm)
	√	Mobile and Portable client device	250mW (24 dBm)
U-NII-2A	-		250mW (24 dBm) or 11 dBm+10 log B*
U-NII-2C	-		250mW (24 dBm) or 11 dBm+10 log B*
U-NII-3	√		1 Watt (30 dBm)

*B is the 26 dB emission bandwidth in megahertz

4.3.2 Test Setup

For Power Output
802.11a, 802.11n (HT20), 802.11n (HT40)

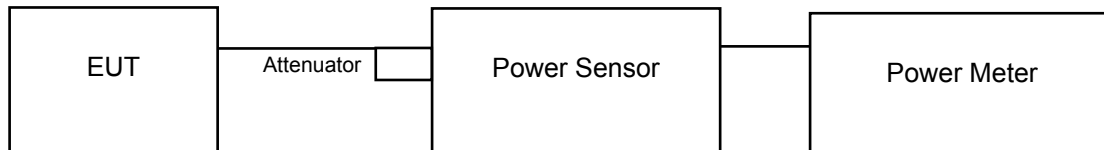

802.11ac (VHT80)

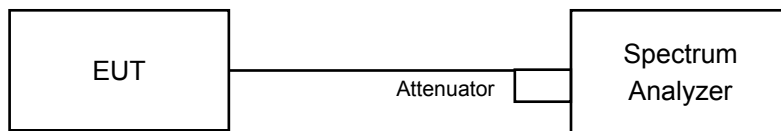

4.3.3 Test Instruments

Refer to section 4.1.2 to get information of above instrument.

4.3.4 Test Procedure

For Average Power Measurement

For 802.11a, 802.11n (HT20), 802.11n (HT40)

Method PM is used to perform output power measurement, trigger and gating function of wide band power meter is enabled to measure max output power of TX on burst and set the detector to average. Duty factor is not added to measured value.

For 802.11ac (VHT80)

- a. Set span to encompass the entire 26 dB EBW (or, alternatively, the entire 99% occupied bandwidth) of the signal.
- b. Set sweep trigger to “free run”.
- c. Set RBW = 1 MHz.
- d. Set VBW \geq 3 MHz.
- e. Number of points in sweep \geq 2 Span / RBW.
- f. Sweep time \leq (number of points in sweep) * T
- g. Using emission bandwidth to determine the frequency span for integration the channel bandwidth.
- h. Detector = RMS.
- i. Trace mode = max hold.
- j. Allow max hold to run for at least 60 seconds, or longer as needed to allow the trace to stabilize.
- k. Compute power by integrating the spectrum across the EBW (or, alternatively, the entire 99% occupied bandwidth) of the signal using the instrument’s band power measurement function with band limits set equal to the EBW (or occupied bandwidth) band edges. If the instrument does not have a band power function, sum the spectrum levels (in power units) at 1 MHz intervals extending across the EBW (or, alternatively, the entire 99% occupied bandwidth) of the spectrum.

4.3.5 Deviation from Test Standard

No deviation.

4.3.6 EUT Operating Conditions

The software provided by client to enable the EUT under transmission condition continuously at lowest, middle and highest channel frequencies individually.

4.3.7 Test Result

Power Output:

802.11a

Chan.	Freq. (MHz)	Maximum Conducted Power (mW)	Maximum Conducted Power (dBm)	Power Limit (dBm)	Pass / Fail
36	5180	19.187	12.83	24.00	Pass
40	5200	19.320	12.86	24.00	Pass
48	5240	18.578	12.69	24.00	Pass
149	5745	14.655	11.66	30.00	Pass
157	5785	15.241	11.83	30.00	Pass
165	5825	15.346	11.86	30.00	Pass

802.11n (HT20)

Chan.	Freq. (MHz)	Maximum Conducted Power (mW)	Maximum Conducted Power (dBm)	Power Limit (dBm)	Pass / Fail
36	5180	17.022	12.31	24.00	Pass
40	5200	19.187	12.83	24.00	Pass
48	5240	18.836	12.75	24.00	Pass
149	5745	14.488	11.61	30.00	Pass
157	5785	15.031	11.77	30.00	Pass
165	5825	15.205	11.82	30.00	Pass

802.11n (HT40)

Chan.	Freq. (MHz)	Maximum Conducted Power (mW)	Maximum Conducted Power (dBm)	Power Limit (dBm)	Pass / Fail
38	5190	8.831	9.46	24.00	Pass
46	5230	15.631	11.94	24.00	Pass
151	5755	12.106	10.83	30.00	Pass
159	5795	12.503	10.97	30.00	Pass

802.11ac (VHT80)

Chan.	Freq. (MHz)	Maximum Conducted Power (mW)	Maximum Conducted Power (dBm)	Power Limit (dBm)	Pass / Fail
42	5210	4.667	6.69	24.00	Pass
155	5775	19.099	12.81	30.00	Pass

4.4 Occupied Bandwidth Measurement

4.4.1 Test Setup

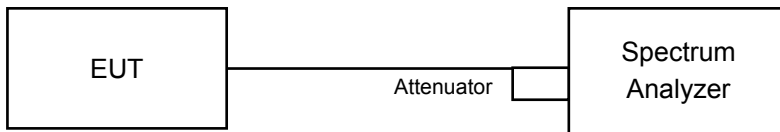

4.4.2 Test Instruments

Refer to section 4.1.2 to get information of above instrument.

4.4.3 Test Procedure

The transmitter output was connected to the spectrum analyzer through an attenuator. The bandwidth of the fundamental frequency was measured by spectrum analyzer with resolution bandwidth in the range of 1% to 5% of the anticipated emission bandwidth, and a video bandwidth at least 3x the resolution bandwidth and set the detector to sampling. The width of a frequency band such that, below the lower and above the upper frequency limits, the mean powers emitted are each equal to a specified percentage 0.5 %of the total mean power of a given emission.

4.4.4 Test Result

802.11a

Chan.	Freq. (MHz)	Occupied Bandwidth (MHz)
36	5180	16.92
40	5200	16.80
48	5240	16.80
149	5745	16.80
157	5785	16.80
165	5825	16.68

802.11n (HT20)

Chan.	Freq. (MHz)	Occupied Bandwidth (MHz)
36	5180	17.76
40	5200	17.76
48	5240	17.88
149	5745	17.76
157	5785	17.76
165	5825	17.76

802.11n (HT40)

Chan.	Freq. (MHz)	Occupied Bandwidth (MHz)
38	5190	36.48
46	5230	36.48
151	5755	36.36
159	5795	36.48

802.11ac (VHT80)

Chan.	Freq. (MHz)	Occupied Bandwidth (MHz)
42	5210	76.08
155	5775	76.32

Spectrum Plot of Worst Value

802.11a

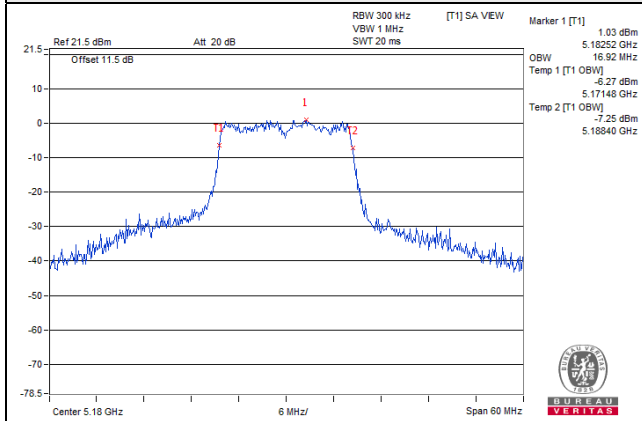

802.11n (HT20)

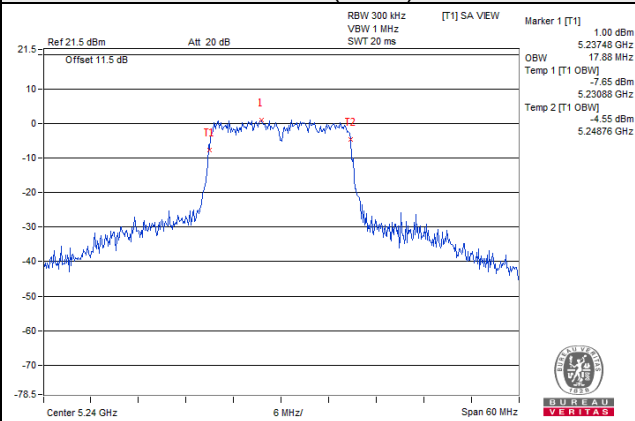

802.11n (HT40)

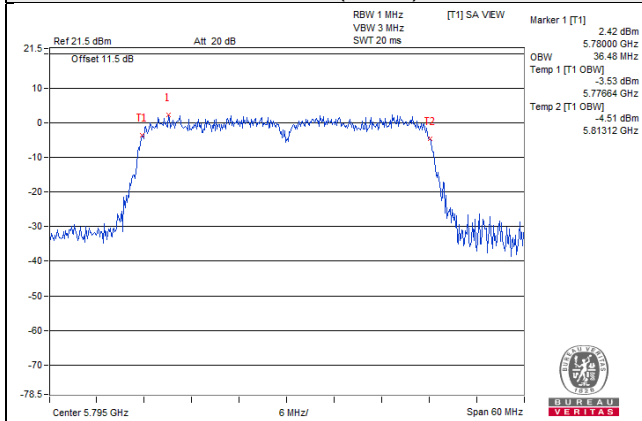

802.11ac (VHT80)

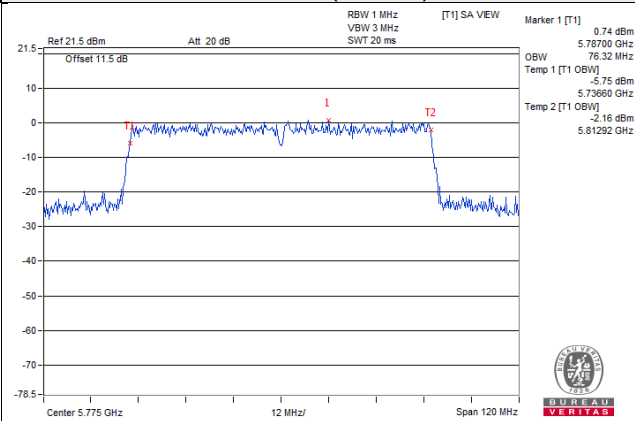

4.5 Peak Power Spectral Density Measurement

4.5.1 Limits of Peak Power Spectral Density Measurement

Operation Band	EUT Category		Limit
U-NII-1		Outdoor Access Point	17dBm/ MHz
		Fixed point-to-point Access Point	
		Indoor Access Point	
	√	Mobile and Portable client device	11dBm/ MHz
U-NII-2A			11dBm/ MHz
U-NII-2C			11dBm/ MHz
U-NII-3	√		30dBm/ 500kHz

4.5.2 Test Setup

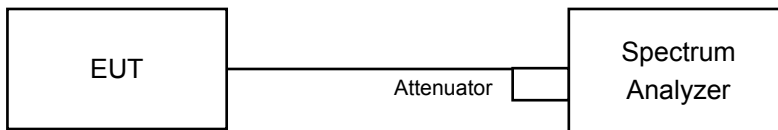

4.5.3 Test Instruments

Refer to section 4.1.2 to get information of above instrument.

4.5.4 Test Procedures

For U-NII-1 band:

Duty cycle of test signal is > 98%

Using method SA-1

- Set span to encompass the entire emission bandwidth (EBW) of the signal.
- Set RBW = 1 MHz, Set VBW ≥ 3 MHz, Detector = RMS
- Sweep time = auto, trigger set to “free run”.
- Trace average at least 100 traces in power averaging mode.
- Record the max value

Duty cycle of test signal is < 98%

Using method SA-2

- Set span to encompass the entire emission bandwidth (EBW) of the signal.
- Set RBW = 1MHz, Set VBW ≥ 3 MHz, Detector = RMS
- Set Channel power measure = 1MHz
- Sweep time = auto, trigger set to “free run”.
- Trace average at least 100 traces in power averaging mode.
- Record the max value and add 10 log (1/duty cycle)

For U-NII-3 band:

Duty cycle of test signal is > 98%

- a. Set span to encompass the entire emission bandwidth (EBW) of the signal.
- b. Set RBW = 300 kHz, Set VBW \geq 1 MHz, Detector = RMS
- c. Use the peak marker function to determine the maximum power level in any 300 kHz band segment within the fundamental EBW.
- d. Scale the observed power level to an equivalent value in 500 kHz by adjusting (reducing) the measured power by a bandwidth correction factor (BWCF) where $BWCF = 10\log(500 \text{ kHz}/300\text{kHz})$
- e. Sweep time = auto, trigger set to "free run".
- f. Trace average at least 100 traces in power averaging mode.
- g. Record the max value

Duty cycle of test signal is < 98%

- a. Set span to encompass the entire emission bandwidth (EBW) of the signal.
- b. Set RBW = 300 kHz, Set VBW \geq 1 MHz, Detector = RMS
- c. Use the peak marker function to determine the maximum power level in any 300 kHz band segment within the fundamental EBW.
- d. Scale the observed power level to an equivalent value in 500 kHz by adjusting (reducing) the measured power by a bandwidth correction factor (BWCF) where $BWCF = 10\log(500 \text{ kHz} / 300 \text{ kHz})$
- e. Sweep time = auto, trigger set to "free run".
- f. Trace average at least 100 traces in power averaging mode.
- g. Record the max value and add $10 \log (1/\text{duty cycle})$

4.5.5 Deviation from Test Standard

No deviation.

4.5.6 EUT Operating Conditions

Same as 4.3.6.

4.5.7 Test Results

For U-NII-1 band:

802.11a

Chan.	Freq. (MHz)	PSD w/o Duty Factor (dBm/MHz)	Duty Factor (dB)	PSD with Duty Factor (dBm/MHz)	Max. Limit (dBm/MHz)	Pass / Fail
36	5180	-2.64	0.12	-2.52	11.00	Pass
40	5200	-2.34	0.12	-2.22	11.00	Pass
48	5240	-2.15	0.12	-2.03	11.00	Pass

Note: Refer to section 3.3 for duty cycle spectrum plot.

802.11n (HT20)

Chan.	Freq. (MHz)	PSD w/o Duty Factor (dBm/MHz)	Duty Factor (dB)	PSD with Duty Factor (dBm/MHz)	Max. Limit (dBm/MHz)	Pass / Fail
36	5180	-3.27	0.12	-3.15	11.00	Pass
40	5200	-2.09	0.12	-1.97	11.00	Pass
48	5240	-2.08	0.12	-1.96	11.00	Pass

Note: Refer to section 3.3 for duty cycle spectrum plot.

802.11n (HT40)

Chan.	Freq. (MHz)	PSD (dBm/MHz)	Max. Limit (dBm/MHz)	Pass / Fail
38	5190	-8.93	11.00	Pass
46	5230	-6.21	11.00	Pass

802.11ac (VHT80)

Chan.	Freq. (MHz)	PSD (dBm/MHz)	Max. Limit (dBm/MHz)	Pass / Fail
42	5210	-15.08	11.00	Pass

Spectrum Plot of Worst Value

802.11a

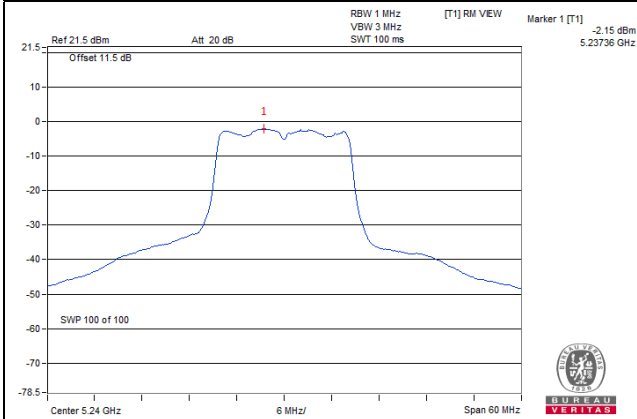

802.11n (HT20)

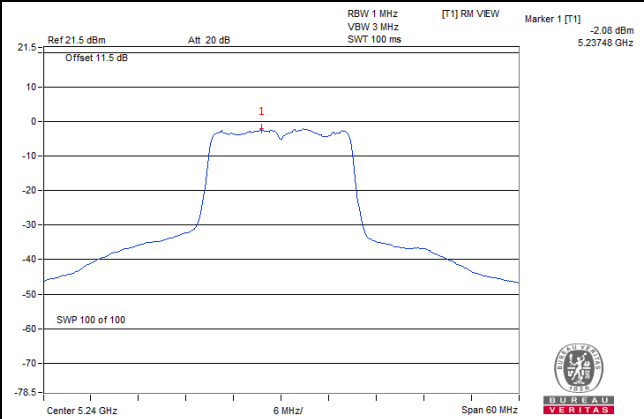

802.11n (HT40)

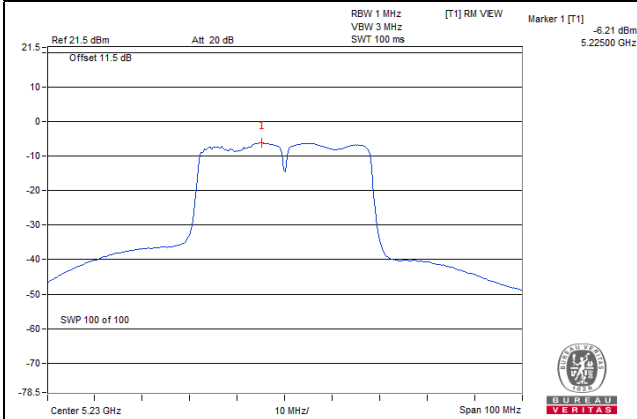

802.11ac (VHT80)

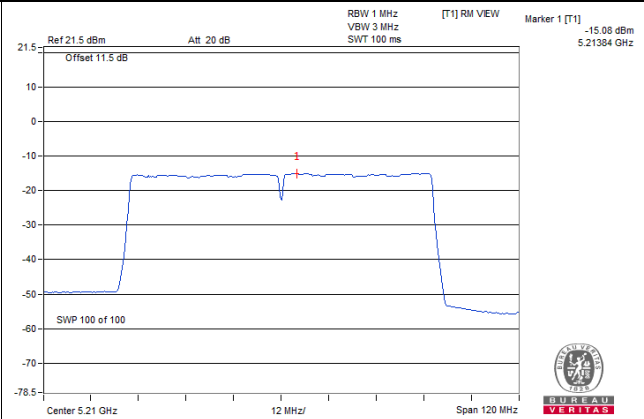

For U-NII-3 band:

802.11a

Chan.	Freq. (MHz)	PSD w/o Duty Factor		Duty Factor (dB)	Total PSD with Duty Factor (dBm/500kHz)	Limit (dBm/500kHz)	Pass / Fail
		(dBm/300kHz)	(dBm/500kHz)				
149	5745	-11.21	-8.99	0.12	-8.87	30.00	Pass
157	5785	-10.74	-8.52	0.12	-8.40	30.00	Pass
165	5825	-10.86	-8.64	0.12	-8.52	30.00	Pass

Note: Refer to section 3.3 for duty cycle spectrum plot.

802.11n (HT20)

Chan.	Freq. (MHz)	PSD w/o Duty Factor		Duty Factor (dB)	Total PSD with Duty Factor (dBm/500kHz)	Limit (dBm/500kHz)	Pass / Fail
		(dBm/300kHz)	(dBm/500kHz)				
149	5745	-11.38	-9.16	0.12	-9.04	30.00	Pass
157	5785	-10.90	-8.68	0.12	-8.56	30.00	Pass
165	5825	-10.67	-8.45	0.12	-8.33	30.00	Pass

Note: Refer to section 3.3 for duty cycle spectrum plot.

802.11n (HT40)

Chan.	Freq. (MHz)	PSD (dBm/300kHz)	PSD (dBm/500kHz)	Limit (dBm/500kHz)	Pass / Fail
151	5755	-15.47	-13.25	30.00	Pass
159	5795	-15.22	-13.00	30.00	Pass

802.11ac (VHT80)

Chan.	Freq. (MHz)	PSD (dBm/300kHz)	PSD (dBm/500kHz)	Limit (dBm/500kHz)	Pass / Fail
155	5775	-17.28	-15.06	30.00	Pass

Spectrum Plot of Worst Value

802.11a

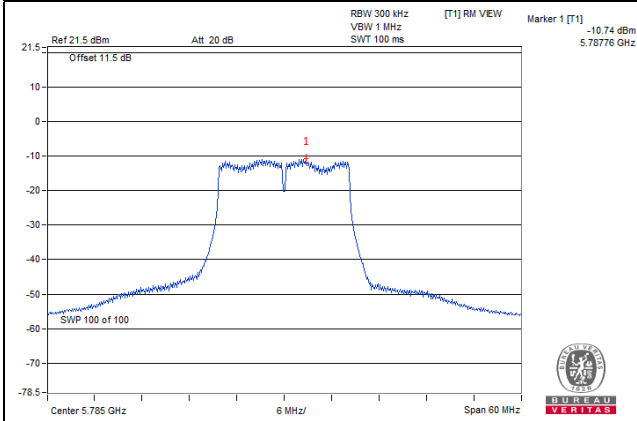

802.11n (HT20)

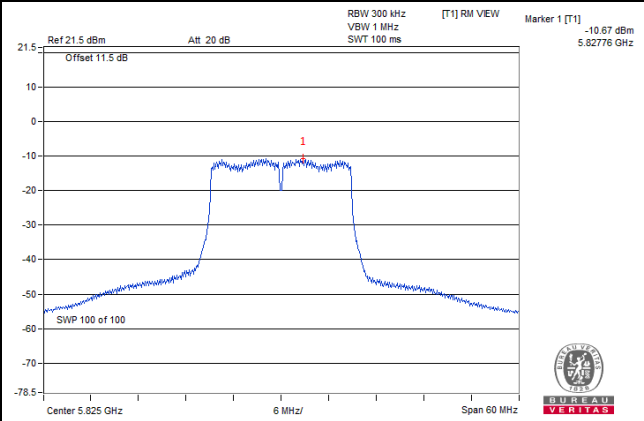

802.11n (HT40)

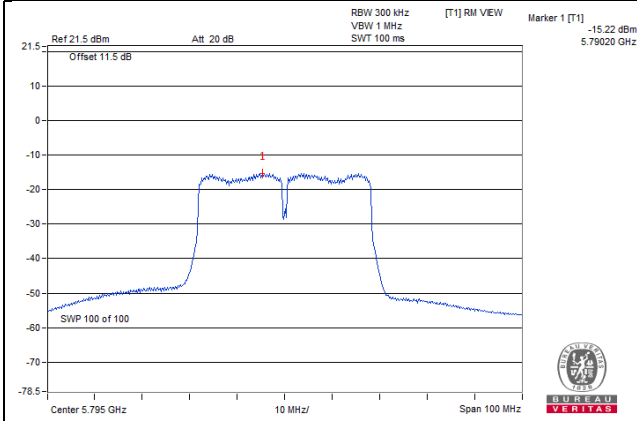

802.11ac (VHT80)

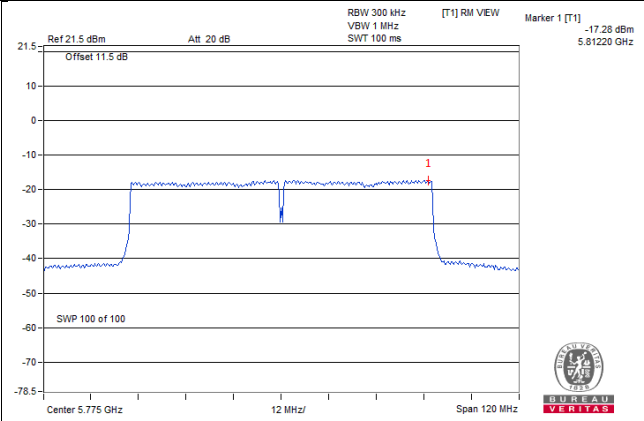

4.6 Frequency Stability

4.6.1 Limits of Frequency Stability Measurement

The frequency of the carrier signal shall be maintained within band of operation

4.6.2 Test Setup

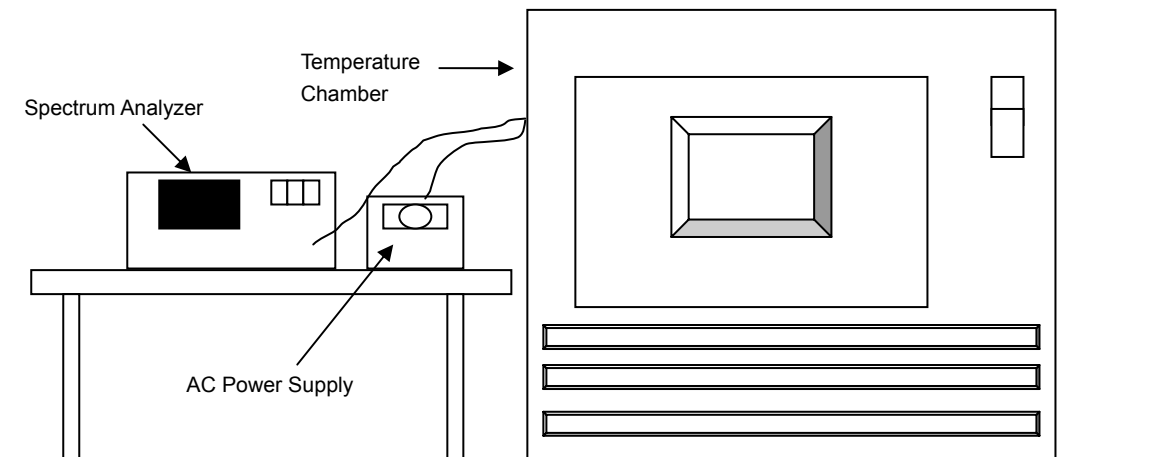

4.6.3 Test Instruments

Refer to section 4.1.2 to get information of above instrument.

4.6.4 Test Procedure

- The EUT was placed inside the environmental test chamber and powered by nominal AC voltage.
- Turn the EUT on and couple its output to a spectrum analyzer.
- Turn the EUT off and set the chamber to the highest temperature specified.
- Allow sufficient time (approximately 30 min) for the temperature of the chamber to stabilize, turn the EUT on and measure the operating frequency after 2, 5, and 10 minutes.
- Repeat step 2 and 3 with the temperature chamber set to the lowest temperature.
- The test chamber was allowed to stabilize at +20 degree C for a minimum of 30 minutes. The supply voltage was then adjusted on the EUT from 85% to 115% and the frequency record.

4.6.5 Deviation from Test Standard

No deviation.

4.6.6 EUT Operating Condition

Set the EUT transmit at un-modulation mode to test frequency stability.

4.6.7 Test Results

Frequency Stability Versus Temp.									
Operating Frequency: 5180MHz									
Temp. (°C)	Power Supply (Vac)	0 Minute		2 Minute		5 Minute		10 Minute	
		Measured Frequency (MHz)	Result	Measured Frequency (MHz)	Result	Measured Frequency (MHz)	Result	Measured Frequency (MHz)	Result
50	120	5180.0151	Pass	5180.0172	Pass	5180.0142	Pass	5180.0167	Pass
40	120	5179.985	Pass	5179.9809	Pass	5179.9821	Pass	5179.9854	Pass
30	120	5179.9826	Pass	5179.979	Pass	5179.9824	Pass	5179.9795	Pass
20	120	5179.9755	Pass	5179.9771	Pass	5179.9748	Pass	5179.9761	Pass
10	120	5180.0242	Pass	5180.0234	Pass	5180.027	Pass	5180.0268	Pass
0	120	5180.0179	Pass	5180.0154	Pass	5180.0137	Pass	5180.0146	Pass
-10	120	5179.9944	Pass	5179.9944	Pass	5179.9945	Pass	5179.9951	Pass
-20	120	5179.9835	Pass	5179.9835	Pass	5179.9843	Pass	5179.9813	Pass
-30	120	5180.0186	Pass	5180.0166	Pass	5180.0185	Pass	5180.0187	Pass

Frequency Stability Versus Voltage									
Operating Frequency: 5180MHz									
Temp. (°C)	Power Supply (Vac)	0 Minute		2 Minute		5 Minute		10 Minute	
		Measured Frequency (MHz)	Result	Measured Frequency (MHz)	Result	Measured Frequency (MHz)	Result	Measured Frequency (MHz)	Result
20	138	5179.9762	Pass	5179.9767	Pass	5179.9756	Pass	5179.9752	Pass
	120	5179.9755	Pass	5179.9771	Pass	5179.9748	Pass	5179.9761	Pass
	102	5179.9753	Pass	5179.9776	Pass	5179.974	Pass	5179.977	Pass

4.7 6dB Bandwidth Measurement

4.7.1 Limits of 6dB Bandwidth Measurement

The minimum of 6dB Bandwidth Measurement is 0.5MHz.

4.7.2 Test Setup

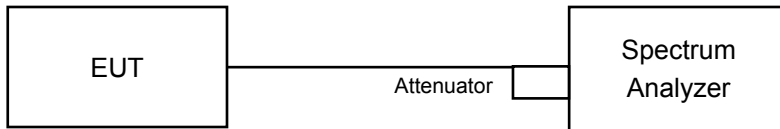

4.7.3 Test Instruments

Refer to section 4.1.2 to get information of above instrument.

4.7.4 Test Procedure

Measurement Procedure REF

- Set resolution bandwidth (RBW) = 100kHz
- Set the video bandwidth (VBW) $\geq 3 \times$ RBW, Detector = Peak.
- Trace mode = max hold.
- Sweep = auto couple.
- Measure the maximum width of the emission that is constrained by the frequencies associated with the two amplitude points (upper and lower) that are attenuated by 6 dB relative to the maximum level measured in the fundamental emission

4.7.5 Deviation from Test Standard

No deviation.

4.7.6 EUT Operating Condition

The software provided by client to enable the EUT under transmission condition continuously at lowest, middle and highest channel frequencies individually.

4.7.7 Test Results

802.11a

Channel	Frequency (MHz)	6dB Bandwidth (MHz)	Minimum Limit (MHz)	Pass / Fail
149	5745	16.62	0.5	Pass
157	5785	16.60	0.5	Pass
165	5825	16.59	0.5	Pass

802.11n (HT20)

Channel	Frequency (MHz)	6dB Bandwidth (MHz)	Minimum Limit (MHz)	Pass / Fail
149	5745	17.75	0.5	Pass
157	5785	17.68	0.5	Pass
165	5825	17.68	0.5	Pass

802.11n (HT40)

Channel	Frequency (MHz)	6dB Bandwidth (MHz)	Minimum Limit (MHz)	Pass / Fail
151	5755	36.56	0.5	Pass
159	5795	36.45	0.5	Pass

802.11ac (VHT80)

Channel	Frequency (MHz)	6dB Bandwidth (MHz)	Minimum Limit (MHz)	Pass / Fail
155	5775	76.85	0.5	Pass

Spectrum Plot of Worst Value

802.11a

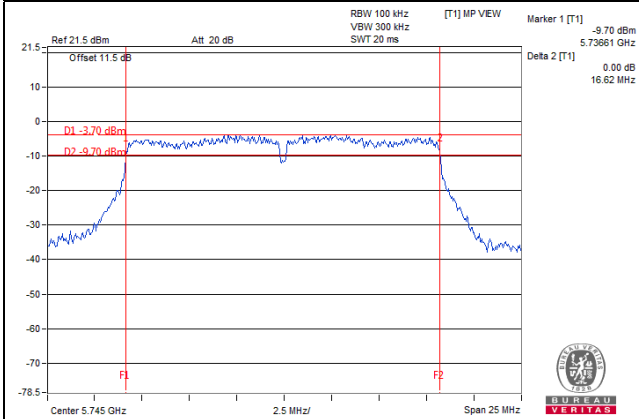

802.11n (HT20)

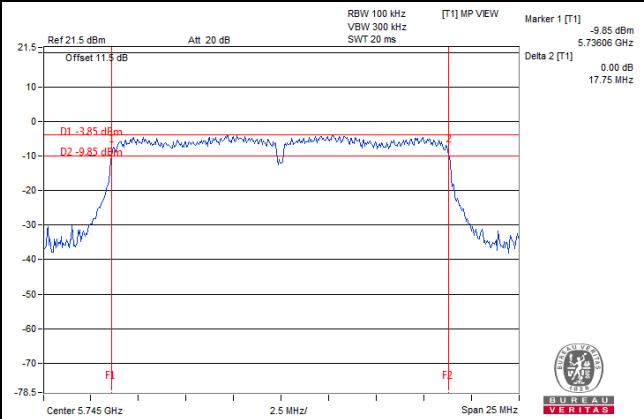

802.11n (HT40)

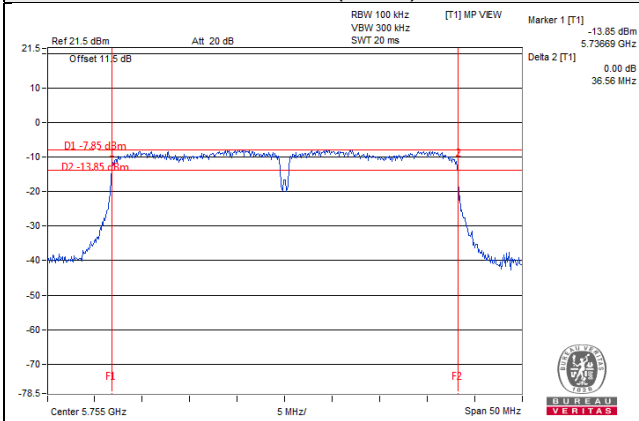

802.11ac (VHT80)

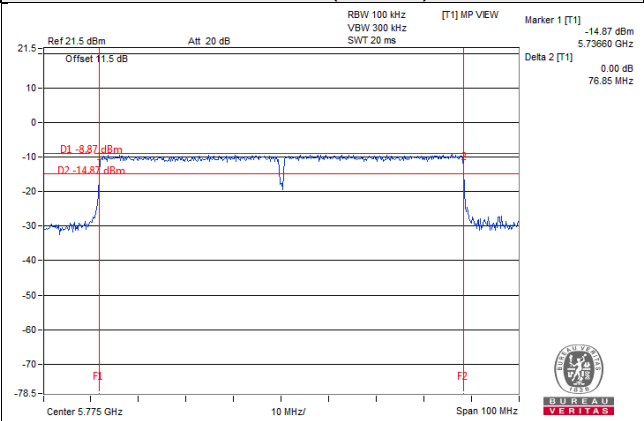

5 Pictures of Test Arrangements

Please refer to the attached file (Test Setup Photo).

Annex A- Radiated Out of Band Emission (OOBE) Measurement (For U-NII-3 band)

802.11a

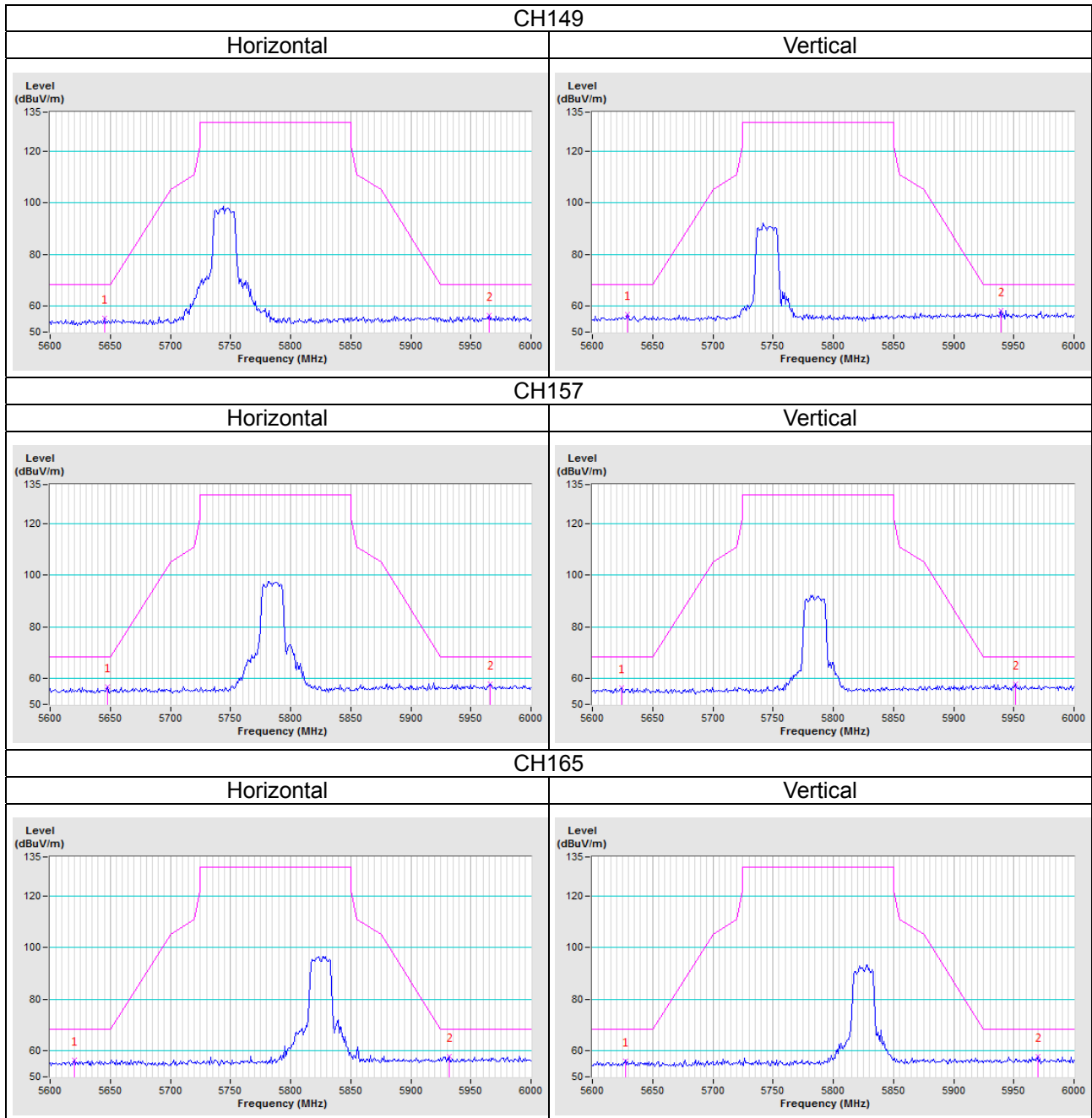

802.11n (HT20)

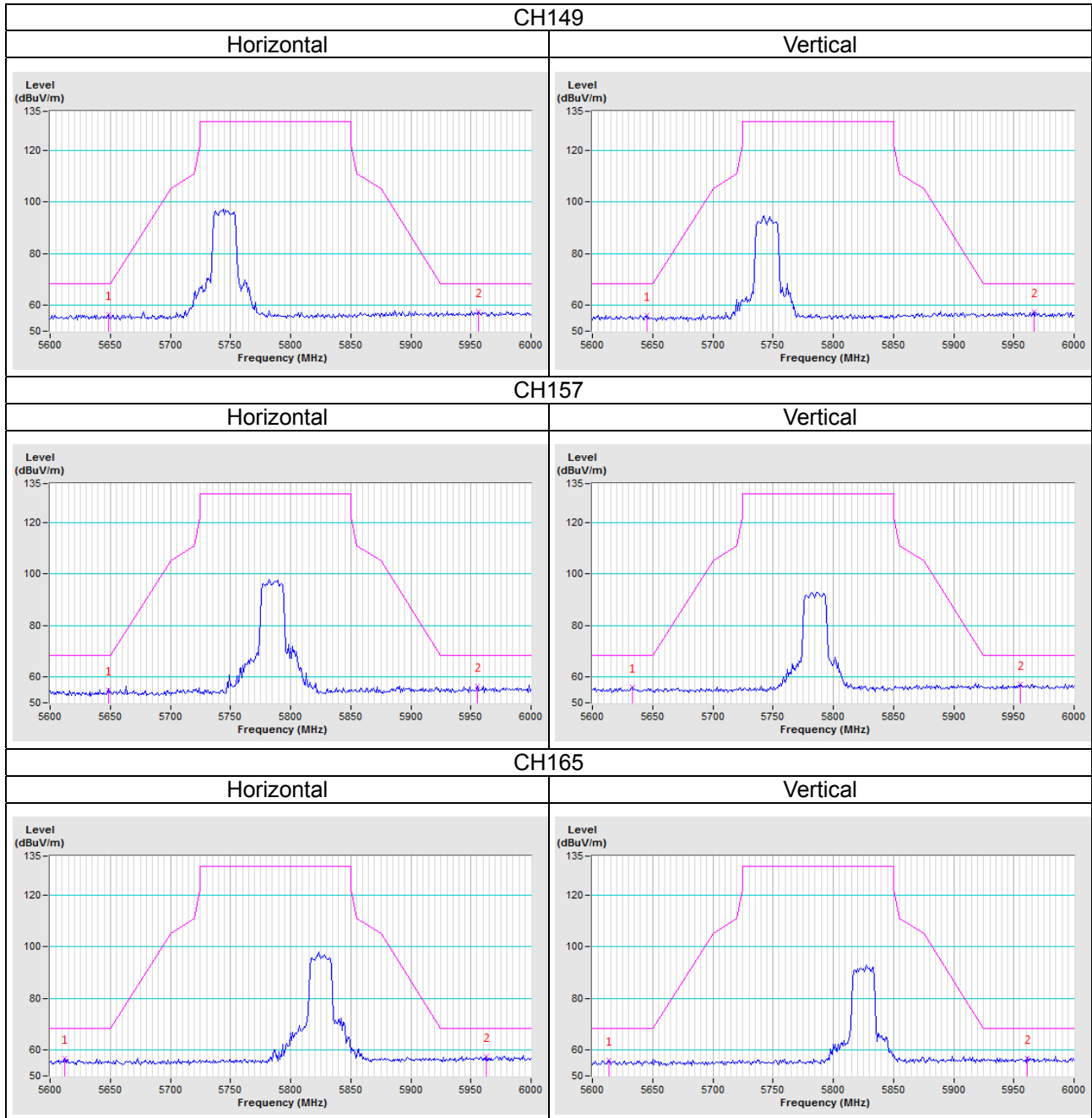

802.11n (HT40)

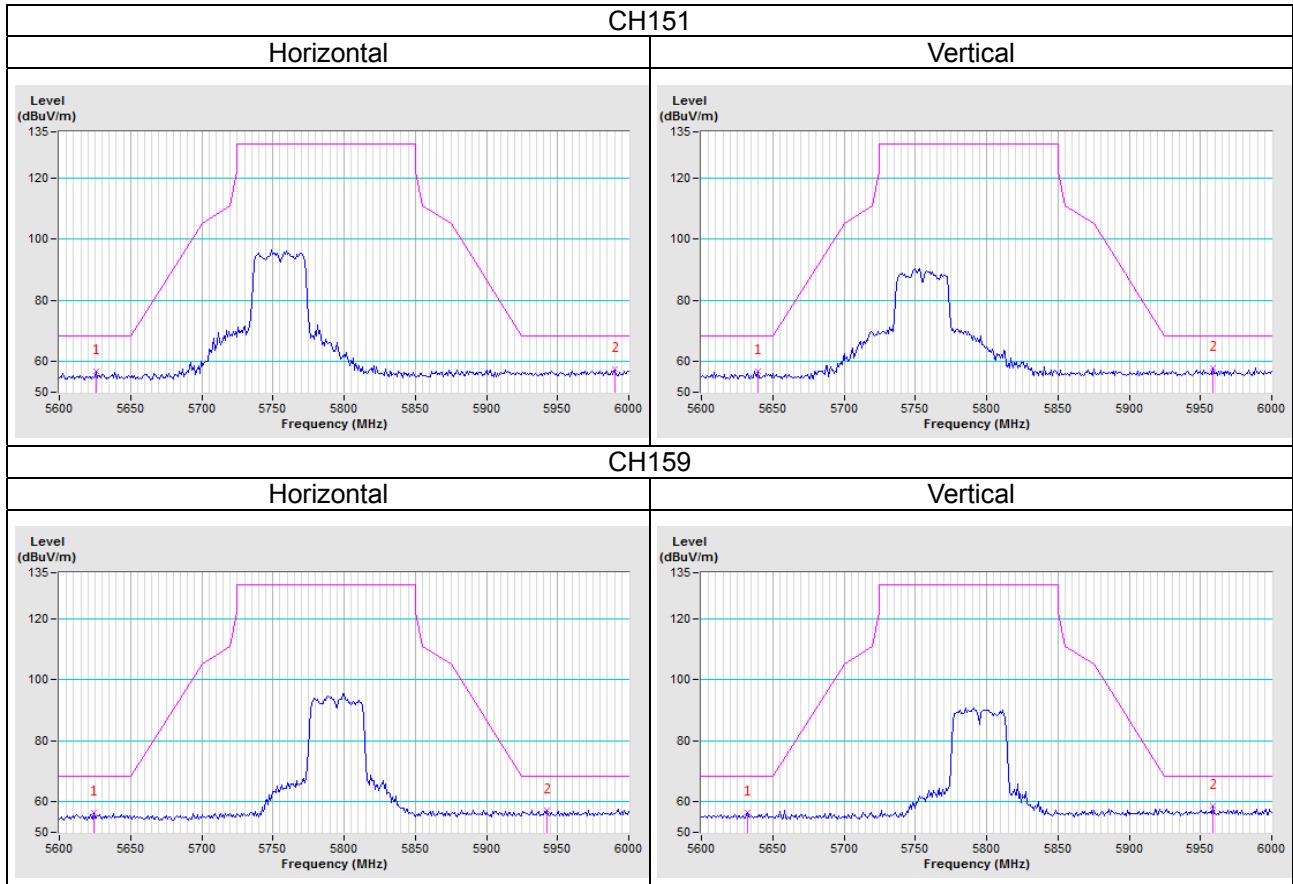

802.11ac (VHT80)

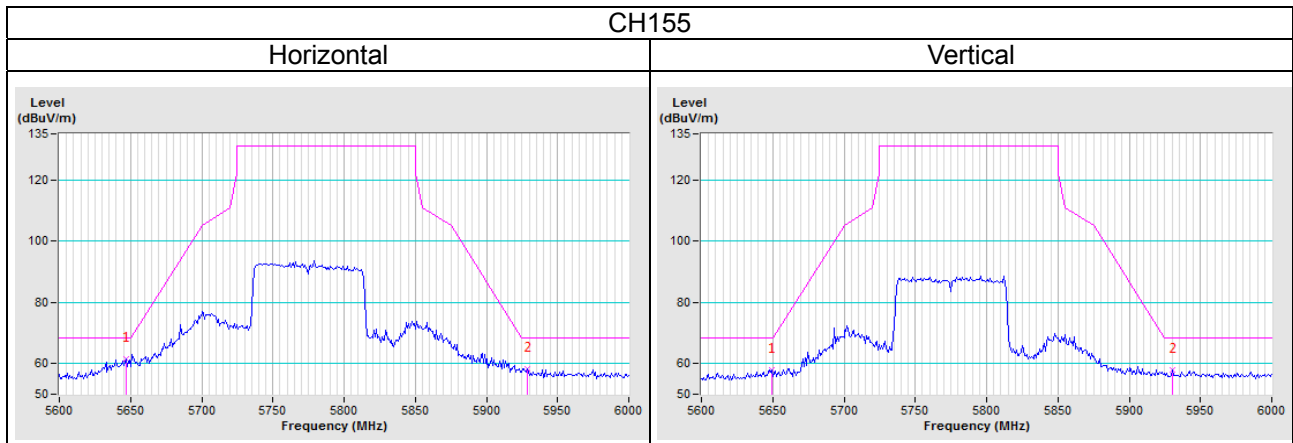

Appendix – Information on the Testing Laboratories

We, Bureau Veritas Consumer Products Services (H.K.) Ltd., Taoyuan Branch, were founded in 1988 to provide our best service in EMC, Radio, Telecom and Safety consultation. Our laboratories are FCC recognized accredited test firms and accredited and approved according to ISO/IEC 17025.

If you have any comments, please feel free to contact us at the following:

Linko EMC/RF Lab

Tel: 886-2-26052180

Fax: 886-2-26051924

Hsin Chu EMC/RF/Telecom Lab

Tel: 886-3-6668565

Fax: 886-3-6668323

Hwa Ya EMC/RF/Safety

Tel: 886-3-3183232

Fax: 886-3-3270892

Email: service.adt@tw.bureauveritas.com

Web Site: www.bureauveritas-adt.com

The address and road map of all our labs can be found in our web site also.

--- END ---