

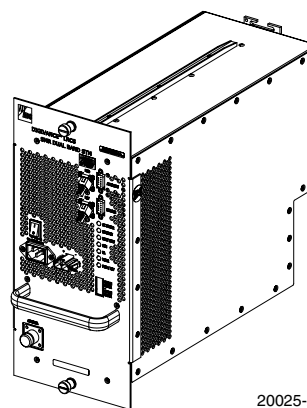

Digivance® LRCS 800/900 MHz SMR System with Version 3.01 EMS Software Operation and Maintenance Manual

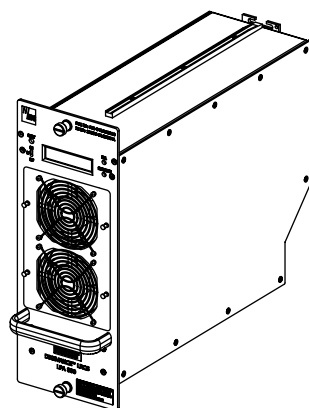

20025-A

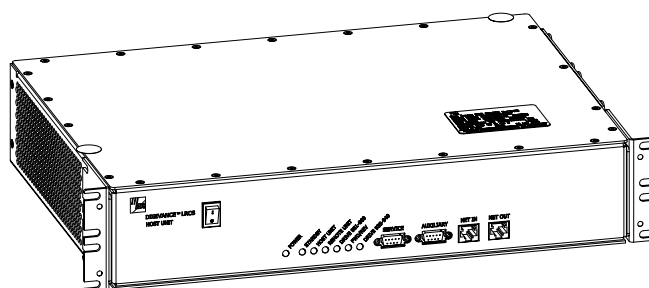

ADCP-75-179
Preliminary Issue A
September 2004

Digivance® LRCS 800/900 MHz SMR System with Version 3.01 EMS Software Operation and Maintenance Manual

COPYRIGHT

© 2004, ADC Telecommunications, Inc.
All Rights Reserved
Printed in the U.S.A.

REVISION HISTORY

ISSUE	DATE	REASON FOR CHANGE
A	09/2004	Original issue.

LIST OF CHANGES

The technical changes incorporated into this issue are listed below.

PAGE	IDENTIFIER	DESCRIPTION OF CHANGE
All		Original issue.

TRADEMARK INFORMATION

ADC and Digivance are registered trademarks of ADC Telecommunications, Inc.

Stargazer is a registered trademark of ADC DSL Systems, Inc.

Procomm Plus is a registered trademark of Quarterdeck Corporation.

Acrobat and Adobe are registered trademarks of Adobe Systems, Inc.

DISCLAIMER OF LIABILITY

Contents herein are current as of the date of publication. ADC reserves the right to change the contents without prior notice. **In no event shall ADC be liable for any damages resulting from loss of data, loss of use, or loss of profits and ADC further disclaims any and all liability for indirect, incidental, special, consequential or other similar damages. This disclaimer of liability applies to all products, publications and services during and after the warranty period.**

This publication may be verified at any time by contacting ADC's Technical Assistance Center at 1-800-366-3891, extension 73476 (in U.S.A. or Canada) or 952-917-3476 (outside U.S.A. and Canada), or by e-mail to wireless.tac@adc.com



ADC Telecommunications, Inc.
P.O. Box 1101, Minneapolis, Minnesota 55440-1101
In U.S.A. and Canada: 1-800-366-3891
Outside U.S.A. and Canada: (952) 938-8080
Fax: (952) 917-1717

TABLE OF CONTENTS

Content	Page
ABOUT THIS MANUAL	vii
RELATED PUBLICATIONS	vii
ADMONISHMENTS	viii
GENERAL SAFETY PRECAUTIONS	viii
STANDARDS CERTIFICATION	ix
LIST OF ACRONYMS AND ABBREVIATIONS	ix

SECTION 1: OVERVIEW

1 INTRODUCTION	1-1
2 LRCS SYSTEM OVERVIEW	1-1
2.1 Basic System Components	1-1
2.2 Enhanced Base Transceiver Station Interface	1-3
2.3 Handset Interface	1-3
2.4 Local Interface	1-3
2.5 Network Operations Center Interface	1-5
2.6 SNMP Interface	1-6
3 SYSTEM FUNCTIONS AND FEATURES	1-7
3.1 Fiber Optic Transport	1-7
3.2 Control and Monitoring Software	1-9
3.3 Fault Detection and Alarm Reporting	1-9
3.4 Powering	1-9
3.5 Equipment Mounting and Configuration	1-9

SECTION 2: DESCRIPTION

1 INTRODUCTION	2-3
2 HOST UNIT	2-3
2.1 Primary Components	2-3
2.2 Mounting	2-3
2.3 Fault Detection and Alarm Reporting	2-4
2.4 RF Signal Connections	2-4
2.5 RF Signal Level Adjustments	2-5
2.6 Propagation Delay	2-5
2.7 Optical Connection	2-5
2.8 Controller Area Network Interface Connection	2-5
2.9 Service Interface Connection	2-5
2.10 Auxiliary Interface Connector	2-5
2.11 Powering	2-6
2.12 Cooling	2-6

TABLE OF CONTENTS

Content	Page
2.13 User Interface	2-6
3 SPECTRUM TRANSPORT MODULE	2-8
3.1 Primary Components	2-8
3.2 Mounting	2-9
3.3 Fault Detection and Alarm Reporting	2-9
3.4 Antenna Cable Connection	2-10
3.5 RF Signal Level Adjustment	2-10
3.6 Optical Connection	2-10
3.7 Service Interface Connection	2-10
3.8 Auxiliary Interface Connection	2-10
3.9 Powering	2-10
3.10 Cooling	2-11
3.11 User Interface	2-11
4 35 WATT LINEAR POWER AMPLIFIER	2-13
4.1 Primary Components	2-13
4.2 Mounting	2-14
4.3 Fault Detection and Alarm Reporting	2-14
4.4 Powering	2-14
4.5 Cooling	2-14
4.6 User Interface	2-14
5 REMOTE UNIT MOUNTING SHELF	2-16
5.1 Indoor Mounting Shelf	2-16
6 SLIM-STYLE REMOTE UNIT CABINETS	2-17
6.1 Slim-Style Single-STM Cabinet	2-18
6.2 Slim-Style Dual-STM Cabinet	2-20
7 ACCESSORY ITEMS	2-23
7.1 Remote Unit Back-up Battery Kit	2-23
7.2 Wavelength Division Multiplexer System	2-24
7.3 Coarse Wavelength Division Multiplexer System	2-25
8 DIGIVANCE ELEMENT MANAGEMENT SYSTEM	2-26
8.1 Digivance EMS Primary Components	2-26
8.2 Software Installation	2-28
8.3 Computer Operation	2-28
8.4 Digivance EMS Computer Interface Connections	2-28
8.5 Digivance EMS User Interfaces	2-29
9 SPECIFICATIONS	2-31
 SECTION 3: OPERATION	
1 BEFORE STARTING OPERATION	3-1
1.1 Tools and Materials	3-1

TABLE OF CONTENTS

Content	Page
1.2 Readiness Check	3-2
2 TURN-UP SYSTEM AND VERIFY OPERATION	3-2
2.1 Turn-Up Procedure	3-3
2.2 Check/Download HU and RU Control Program and FPGA Program Software	3-6
2.3 Determine Forward Path Input Signal Level	3-8
2.4 Enter Site Name and Site Number	3-10
2.5 Enter Host Forward Attenuation	3-11
2.6 Determine Output Signal Level at STM Antenna Port	3-13
2.7 Enter Remote Forward Attenuation	3-13
2.8 Enter Host Reverse Attenuation	3-15
2.9 Enter Host Forward and Reverse Delay	3-17
 SECTION 4: MAINTENANCE 	
1 SYSTEM MAINTENANCE OVERVIEW	4-1
1.1 Tools and Materials	4-1
2 FAULT DETECTION AND ALARM REPORTING	4-2
3 FAULT ISOLATION AND TROUBLESHOOTING	4-6
3.1 Host Unit Troubleshooting	4-7
3.2 STM Troubleshooting	4-9
3.3 LPA Troubleshooting	4-13
4 TEST PROCEDURES	4-15
4.1 Optical Power Test	4-15
4.2 Optical Loopback Test	4-17
5 SCHEDULED MAINTENANCE REQUIREMENTS	4-19
 SECTION 5: GENERAL INFORMATION 	
1 WARRANTY/SOFTWARE	5-1
2 SOFTWARE SERVICE AGREEMENT	5-1
3 REPAIR/EXCHANGE POLICY	5-1
4 REPAIR CHARGES	5-2
5 REPLACEMENT/SPARE PRODUCTS	5-2
6 RETURNED MATERIAL	5-2
7 CUSTOMER INFORMATION AND ASSISTANCE	5-3

TABLE OF CONTENTS

Content	Page
---------	------

Blank

ABOUT THIS MANUAL

This installation and operation manual provides the following information:

- An overview of the Digivance 800/900 MHz SMR Long-Range Coverage Solution (LRCS) system.
- A complete description of the basic system components including the Host Unit (HU), Spectrum Transport Module (STM), Linear Power Amplifier (LPA), and Digivance Element Management System (EMS).
- A basic description of the slim-style Remote Unit (RU) cabinets and indoor mounting shelf.
- Procedures for tuning-up the system and verifying that the system is functioning properly.
- Procedures for maintaining the system including scheduled maintenance tasks and fault isolation and troubleshooting procedures.
- Product warranty, repair, return, and replacement information.

The procedures for installing the remote unit modules and enclosures and for installing and using the EMS software are provided in other publications which are referenced in the Related Publications section and at appropriate points within this manual.

RELATED PUBLICATIONS

Listed below are related manuals, their content, and their publication numbers. Copies of these publications can be ordered by contacting the Technical Assistance Center at 1-800-366-3891, extension 73476 (in U.S.A. or Canada) or 952-917-3476 (outside U.S.A. and Canada).

Title/Description	ADCP Number
<p>Digivance LRCS System 800/900 MHz SMR Rear Access Host Unit Installation and Maintenance Manual</p> <p>Provides instructions for mounting the rear access host unit in an equipment rack, installing and connecting the various cables, and replacing the cooling fans.</p>	75-180
<p>Digivance LRCS Dual-STM Systems Supplemental Manual</p> <p>Provides supplemental information for LRCS systems that utilize one of the dual-STM cabinets.</p>	75-157
<p>Digivance Element Management System Version 3.01 User Manual</p> <p>Provides instructions for installing the Digivance Element Management System (EMS) software and for using both the Graphical User Interface (GUI) and the Network Operations Center (NOC) versions of the software.</p>	75-151
<p>Digivance SNMP Agent Software User Manual</p> <p>Describes how to install, configure, and use the LRCS SNMP Proxy Agent.</p>	75-152

ADMONISHMENTS

Important safety admonishments are used throughout this manual to warn of possible hazards to persons or equipment. An admonishment identifies a possible hazard and then explains what may happen if the hazard is not avoided. The admonishments — in the form of Dangers, Warnings, and Cautions — must be followed at all times. These warnings are flagged by use of the triangular alert icon (seen below), and are listed in descending order of severity of injury or damage and likelihood of occurrence.



Danger: *Danger is used to indicate the presence of a hazard that **will** cause severe personal injury, death, or substantial property damage if the hazard is not avoided.*



Warning: *Warning is used to indicate the presence of a hazard that **can** cause severe personal injury, death, or substantial property damage if the hazard is not avoided.*



Caution: *Caution is used to indicate the presence of a hazard that **will** or **can** cause minor personal injury or property damage if the hazard is not avoided.*

GENERAL SAFETY PRECAUTIONS



Danger: *This equipment uses a Class 1 Laser according to FDA/CDRH rules. Laser radiation can seriously damage the retina of the eye. Do not look into the ends of any optical fiber. Do not look directly into the optical transceiver of any digital unit or exposure to laser radiation may result. An optical power meter should be used to verify active fibers. A protective cap or hood **MUST** be immediately placed over any radiating transceiver or optical fiber connector to avoid the potential of dangerous amounts of radiation exposure. This practice also prevents dirt particles from entering the adapter or connector.*



Danger: *Do not look into the ends of any optical fiber. Exposure to laser radiation may result. Do not assume laser power is turned-off or the fiber is disconnected at the other end.*



Danger: *Wet conditions increase the potential for receiving an electrical shock when installing or using electrically-powered equipment. To prevent electrical shock, never install or use electrical equipment in a wet location or during a lightning storm.*



Warning: *The HU is powered by 48 VDC power which is supplied over customer-provided wiring. To prevent electrical shock when installing or modifying the HU power wiring, disconnect the wiring at the power source before working with uninsulated wires or terminals.*



Caution: *Always allow sufficient fiber length to permit routing of patch cords and pigtails without severe bends. Fiber optic patch cords or pigtails may be permanently damaged if bent or curved to a radius of less than 2 inches (50 mm).*

STANDARDS CERTIFICATION

FCC: This equipment complies with the applicable sections of Title 47 CFR Part 90. Installation requirements the licensee needs to follow are listed in Title 47 CFR 90.635. This document may be found at the following website: http://www.access.gpo.gov/nara/cfr/waisidx_03/47cfr90_03.html.

UL/CUL: This equipment complies with UL and CUL 50 Standard for Enclosures for Electrical Equipment. This equipment provides the degree of protection specified by IP43 as defined in IEC Publication 529.

FDA/CDRH: This equipment uses a Class 1 LASER according to FDA/CDRH Rules. This product conforms to all applicable standards of 21 CFR Part 1040.

IC: This equipment complies with the applicable sections of RSS-131. The term “IC:” before the radio certification number only signifies that Industry Canada Technical Specifications were met.

LIST OF ACRONYMS AND ABBREVIATIONS

The acronyms and abbreviations used in this manual are detailed in the following list:

AC	Alternating Current
ASCII	American Standard Code for Information Interchange
Att	Attenuation
AWG	American Wire Gauge
BER	Bit Error Rate
C	Centigrade
CAN	Controller Area Network
CDRH	Center for Devices and Radiological Health
CD-ROM	Compact Disk Read Only Memory
COM	Common
COMM	Communication
Config	Configuration
CWDM	Coarse Wavelength Division Multiplexer
CUL	Canadian Underwriters Laboratories
DC	Direct Current
DCE	Data Communications Equipment
DTE	Data Terminal Equipment
EBTS	Enhanced Base Transceiver Station
EIA	Electronic Industries Association
EMS	Element Management System
ESD	Electrostatic Discharge
F	Fahrenheit
FCC	Federal Communications Commission
FDA	Food and Drug Administration

FSO	Free Space Optics
Fwd	Forward
GFCI	Ground Fault Circuit Interrupter
GUI	Graphical User Interface
HU	Host Unit
IC	Industry Canada
IP	Internet Protocol
LED	Light Emitting Diode
LPA	Linear Power Amplifier
LRCS	Long-Range Coverage Solution
MHz	Mega Hertz
MIB	Management Information Base
MPE	Maximum Permissible Exposure
MTBF	Mean Time Between Failure
NC	Normally Closed
NEM	Network Element Manager
NO	Normally Open
NOC	Network Operations Center
NPT	National Pipe Tapered
OSP	Outside Plant
PA	Power Amplifier
PC	Personal Computer
PCS	Personal Communications System
Prg	Program
Pwr	Power
Rev	Reverse
RF	Radio Frequency
RIM	Radio Interface Module
RMA	Return Material Authorization
RU	Remote Unit
RX	Receive or Receiver
SNMP	Simple Network Management Protocol
SMR	Specialized Mobile Radio
STM	Spectrum Transport Module
TX	Transmit or Transmitter
UL	Underwriters Laboratories
VAC	Volts Alternating Current
VDC	Volts Direct Current
VSWR	Voltage Standing Wave Ratio
WECO	Western Electric Company
WDM	Wavelength Division Multiplexer

SECTION 1: OVERVIEW

1	INTRODUCTION	1-1
2	LRCS SYSTEM OVERVIEW	1-1
2.1	Basic System Components	1-1
2.2	Enhanced Base Transceiver Station Interface	1-3
2.3	Handset Interface	1-3
2.4	Local Interface	1-3
2.5	Network Operations Center Interface	1-5
2.6	SNMP Interface	1-6
3	SYSTEM FUNCTIONS AND FEATURES	1-7
3.1	Fiber Optic Transport	1-7
3.2	Control and Monitoring Software	1-9
3.3	Fault Detection and Alarm Reporting	1-9
3.4	Powering	1-9
3.5	Equipment Mounting and Configuration	1-9

1 INTRODUCTION

This section provides basic description, application, and configuration information about the Digivance Long-Range Coverage Solution (LRCS) system. Throughout this publication, all items referenced as “accessory items” are not furnished with the basic product and must be purchased separately.

2 LRCS SYSTEM OVERVIEW

The Digivance LRCS system is an RF signal transport system that provides long-range RF coverage in areas where it is impractical to place an Enhanced Base Transceiver Station (EBTS) at the antenna site. High real estate costs and community restrictions on tower and equipment locations often make it difficult to install the EBTS at the same location as the antenna. The Digivance LRCS system is designed to overcome equipment placement problems by allowing base stations to be hubbed at a central location while placing antennas at remote locations with minimal real estate requirements. With the Digivance LRCS system, RF signals can be transported to remote locations to expand coverage into areas not receiving service or to extend coverage into difficult to reach areas such as canyons, tunnels, or underground roadways.

2.1 Basic System Components

The basic components of a typical Digivance LRCS system and their function are shown in [Figure 1-1](#). A basic LRCS system consists of a Host Unit (HU) and a Remote Unit (RU). The HU consists of a single-unit assembly that mounts in a standard equipment rack. The RU consists of multiple electronic and optical modules that mount in either an outdoor cabinet or an indoor mounting shelf. Control and monitoring functions are provided by the Digivance Element Management System (EMS). In addition, various accessory items including a back-up battery for the RU, a passive Wavelength Division Multiplexer (WDM) system, and an active Coarse Wavelength Division Multiplexer (CWDM) system are available as accessories.

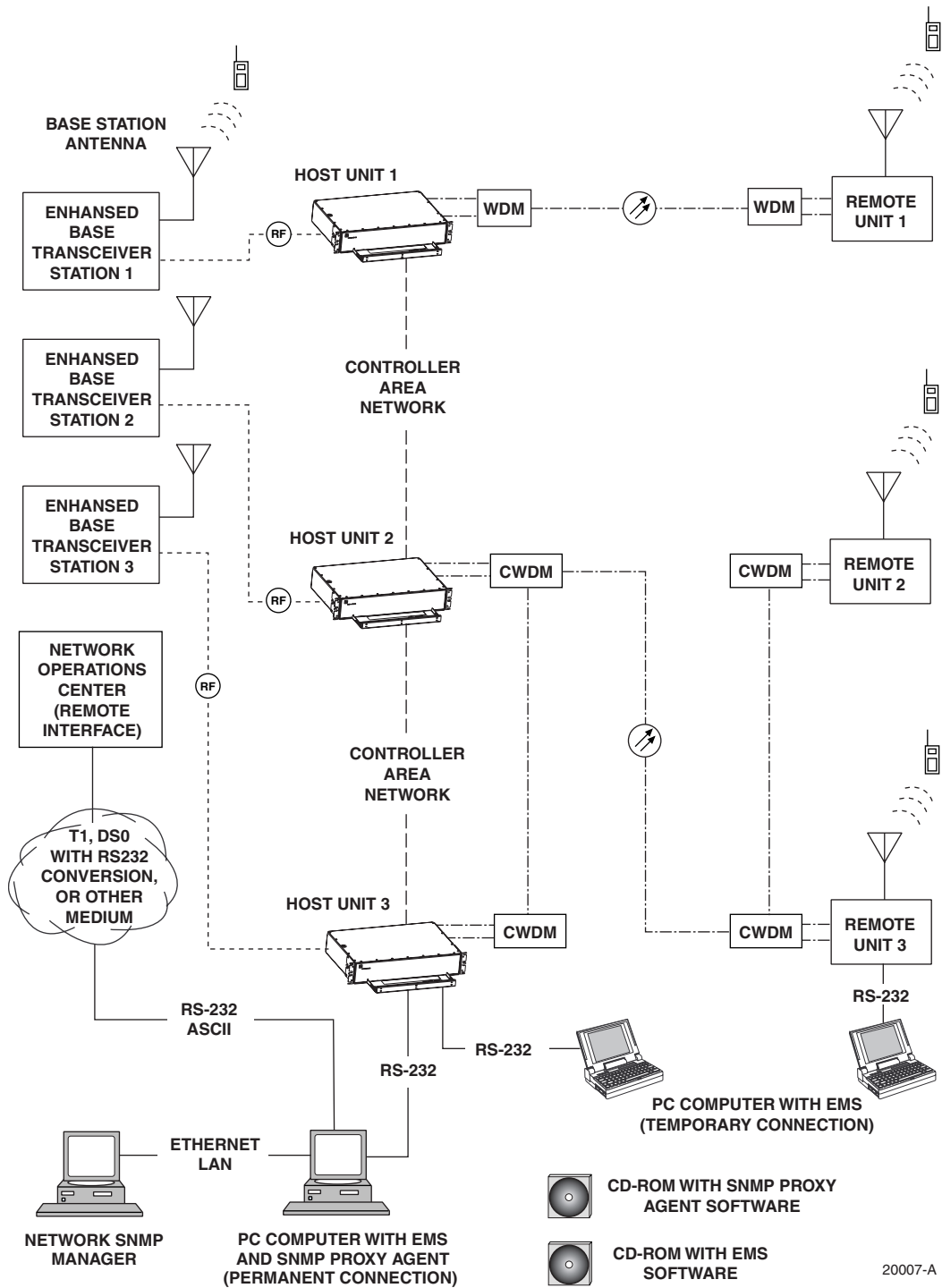

Figure 1-1. System Overview Diagram

2.2 Enhanced Base Transceiver Station Interface

The HU is interfaced with an EBTS over coaxial cables as shown in Figure 1-2. The EBTS provides the RF channel inputs and outputs for a designated sector. In the forward path, the HU receives two RF inputs from the EBTS. The HU digitizes the RF signals and then converts them to digital optical signals for transport to the RU. In the reverse path, the HU receives digital optical signals from the RU. The HU converts the digital optical signals back to two RF outputs which are supplied to the EBTS over the coaxial cable interface.

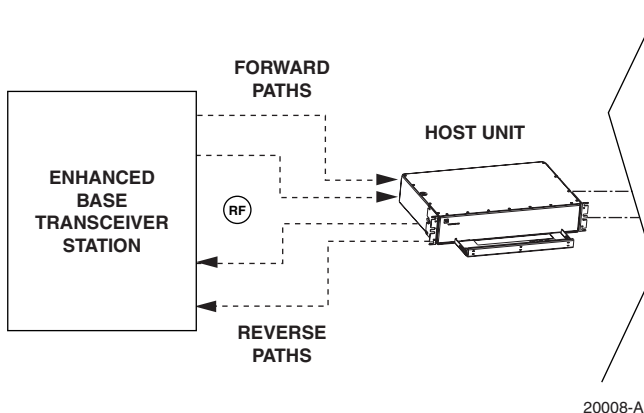

Figure 1-2. EBTS/HU Interface

2.3 Handset Interface

The RU interfaces with the handsets (cell phones) through an antenna. In the reverse path, the RU receives RF signals from each handset (see Figure 1-1). The RU digitizes the RF signals and then converts them to digital optical signals for transport to the HU over the optical fiber link. In the forward path, the RU receives digital optical signals from the HU. The RU converts the optical signals to RF signals for transmission to the handsets. The RU is connected to an antenna (not provided) which transmits and receives the handset RF signals.

2.4 Local Interface

Communications with an individual Digivance system is supported through a local interface capability as shown in Figure 1-3. A local interface requires a PC-type computer loaded with the Digivance Element Management System (EMS) software. EMS provides the various control and monitoring functions required to locally manage a Digivance system. The EMS computer can be directly connected to either the HU or RU through the computer's RS-232 port. Operation is implemented through the EMS Graphical User Interface (GUI). The GUI consists of a series of screens from which the user selects the desired option or function. An RS-232 service port is provided on both the HU and the RU for connecting the EMS computer.

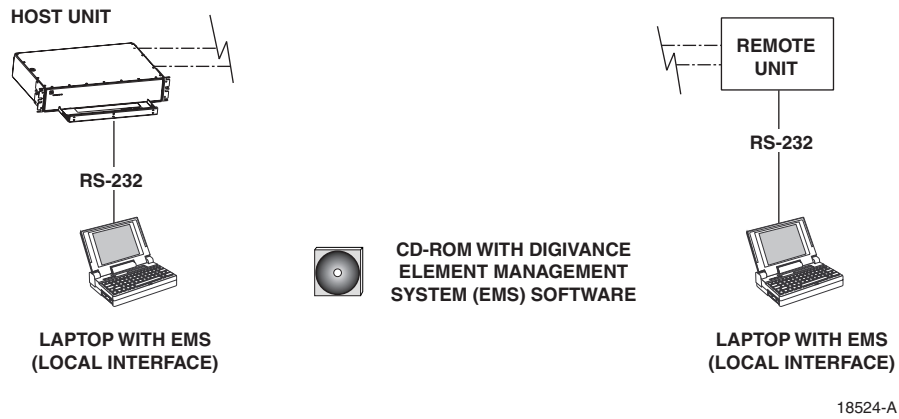

Figure 1-3. Local Management of a Single Digivance System

An EMS computer may be used to locally manage a networked group of multiple Digivance systems as shown in [Figure 1-4](#). A Controller Area Network (CAN) port is provided on each HU. Up to twenty-four HU's may be linked together through the CAN interface and controlled by the same EMS computer. All the networked HU's and the associated RU's may be managed by connecting the EMS computer to one HU. The EMS computer provides an RS-232 port (#1) to support the interface with the networked HU's.

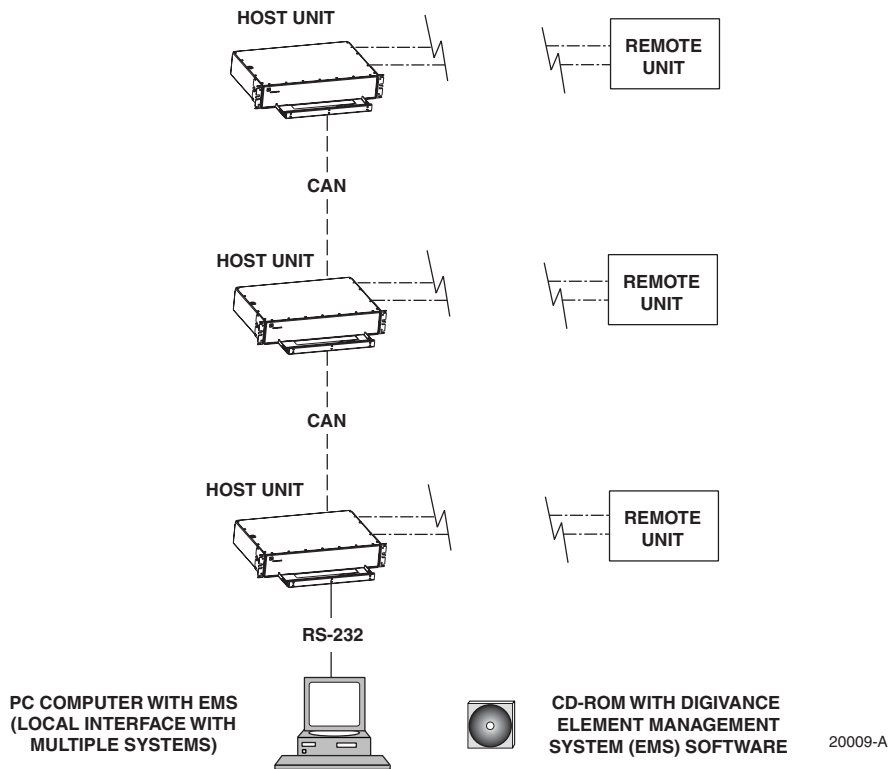

Figure 1-4. Local Management of Networked Digivance Systems

2.5 Network Operations Center Interface

Communications between a Network Operations Center (NOC) and a networked group of multiple Digivance systems is supported by a NOC interface capability as shown in Figure 1-5. To support the NOC interface, a PC-type computer loaded with the Digivance Element Management System (EMS) software is required. EMS provides the various control and monitoring functions required to remotely manage multiple Digivance systems through the NOC interface.

A Controller Area Network (CAN) port is provided on each HU. Up to twenty-four HU's may be linked together through the CAN interface and controlled by the same EMS computer. All the networked HU's and the associated RU's may be managed by connecting the EMS computer to one HU. The EMS computer provides an RS-232 port (#1) to support the interface with the networked HU's.

The NOC can be linked to the EMS computer through a T1 system, DS0 with RS232 conversion, or some other medium. The EMS computer provides an RS-232 ASCII interface port (#2) to support the interface with the NOC.

At the NOC, control and monitoring of the networked Digivance systems is implemented through a Network Element Manager (NEM) interface which requires only a VT100 terminal/emulator for operation. The NEM interface language consists of simple ASCII text strings. All communications are input as either SET or GET commands which result in ASCII text string responses from the specified system or systems.

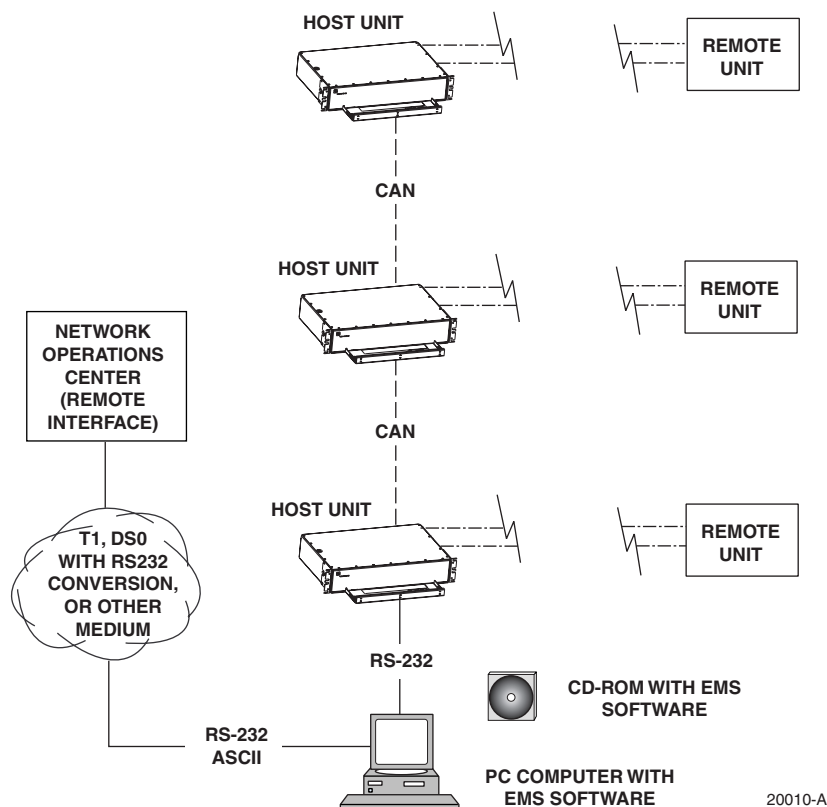

Figure 1-5. Remote Management of Networked Digivance Systems Through NOC Interface

2.6 SNMP Interface

Communications between an external Simple Network Management Protocol (SNMP) Manager and a networked group of multiple Digivance systems is supported by an SNMP interface capability as shown in Figure 1-6. To support the SNMP interface, a PC-type computer loaded with both the Digivance Element Management System (EMS) software and the SNMP Proxy Agent software is required. The EMS and SNMP Proxy Agent software plus the associated Management Information Base (MIB) provide the various control (Set) and monitoring (Get) functions required to remotely manage multiple Digivance systems using an SNMP Manager.

A Controller Area Network (CAN) port is provided on each HU. Up to twenty-four HU's may be linked together through the CAN interface and controlled by the same EMS computer. All the networked HU's and the associated RU's may be managed by connecting the EMS computer to one HU. The EMS computer provides an RS-232 port (#1) to support the interface with the networked HU's.

The SNMP Manager may be linked with the EMS computer through a Local Area Network (LAN). The EMS computer provides an Ethernet port to support the interface with the LAN.

The SNMP Proxy Agent supports two versions of the SNMP protocol: SNMPv1 and SNMPv2c. A facility to Register/Unregister an SNMP Manager for receiving traps is also supported by the SNMP Proxy Agent. The SNMP Manager is not included with the EMS software and must be provided separately.

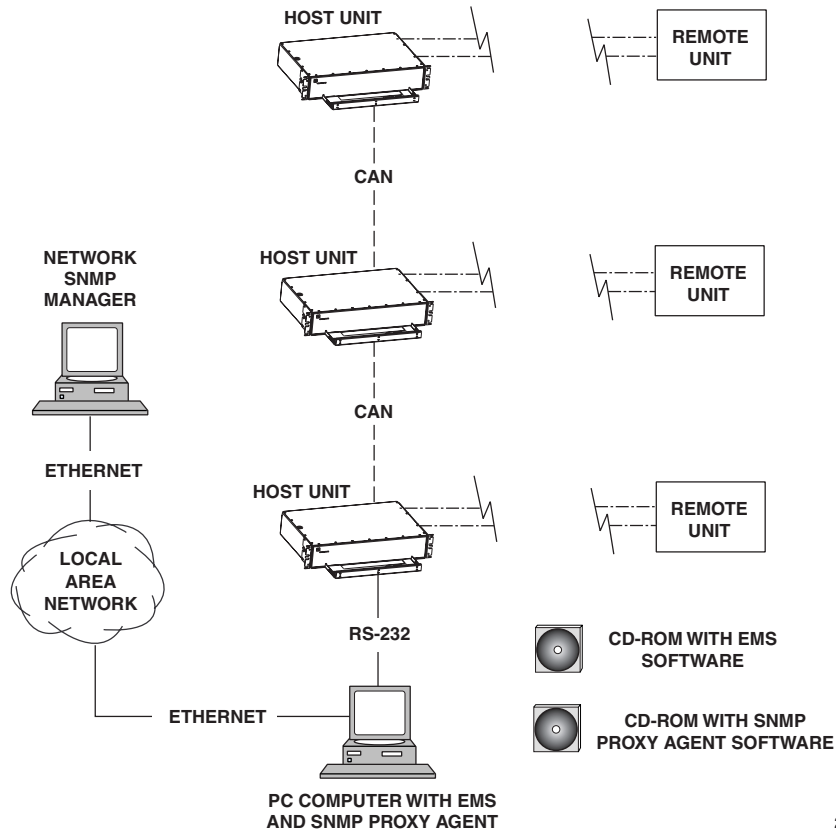

Figure 1-6. Remote Management of Networked Digivance Systems Through SNMP Manager

3 SYSTEM FUNCTIONS AND FEATURES

This section describes various system level functions and features of the Digivance system.

3.1 Fiber Optic Transport

In a typical Digivance system, the HU is connected to the RU over two single-mode optical fibers. One fiber is used to transport the **forward path** optical signal. The other fiber is used to transport the **reverse path** optical signal. Because the optical signal is digital, the input and output RF signal levels at the HU or the RU are not dependent on the level of the optical signal or the length of the optical fiber. A diagram of the fiber optic transport system for a typical Digivance system is shown in [Figure 1-7](#).

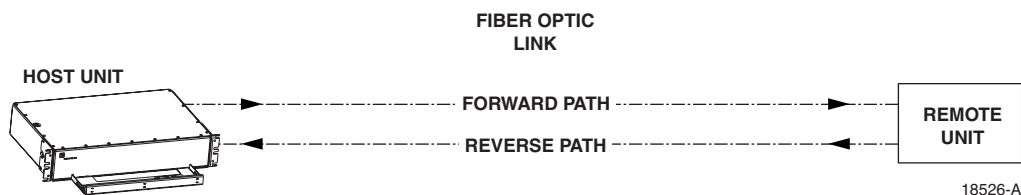

Figure 1-7. Standard Fiber Optic Transport Application

The maximum length of the optical links is dependent on the loss specifications of the optical fiber and the losses imposed by the various connectors and splices. The system provides an optical budget of **25 dB** (typical) when used with 9/125 single-mode fiber.

In some applications, it may be desirable or necessary to combine the forward path and reverse path optical signals from a single HU/RU pair onto a single optical fiber. This can be accomplished by using a passive bi-directional Wavelength Division Multiplexer (WDM) system. The optical wavelengths used in the Digivance system are 1550 nm for the forward path and 1310 nm for the reverse path. Because different wavelengths are used for the forward and reverse paths, both signals can be combined on a single optical fiber. One WDM module is mounted with the HU and the other WDM module is mounted with the RU as shown in [Figure 1-8](#). The WDM system is available as an accessory item.

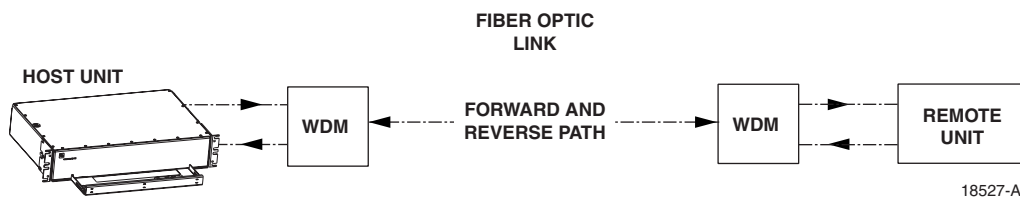

Figure 1-8. Wavelength Division Multiplexer Application

In some applications, it may be desirable or necessary to combine the forward and reverse path optical signals from multiple HU's and RU's onto a single optical fiber. This can be accomplished by using an active Coarse Wavelength Division Multiplexer (CWDM) system. Up to four Digivance systems may be configured to operate over a single optical fiber. A CWDM module is mounted with each HU and RU. An example of a typical CWDM application is shown in Figure 1-9.

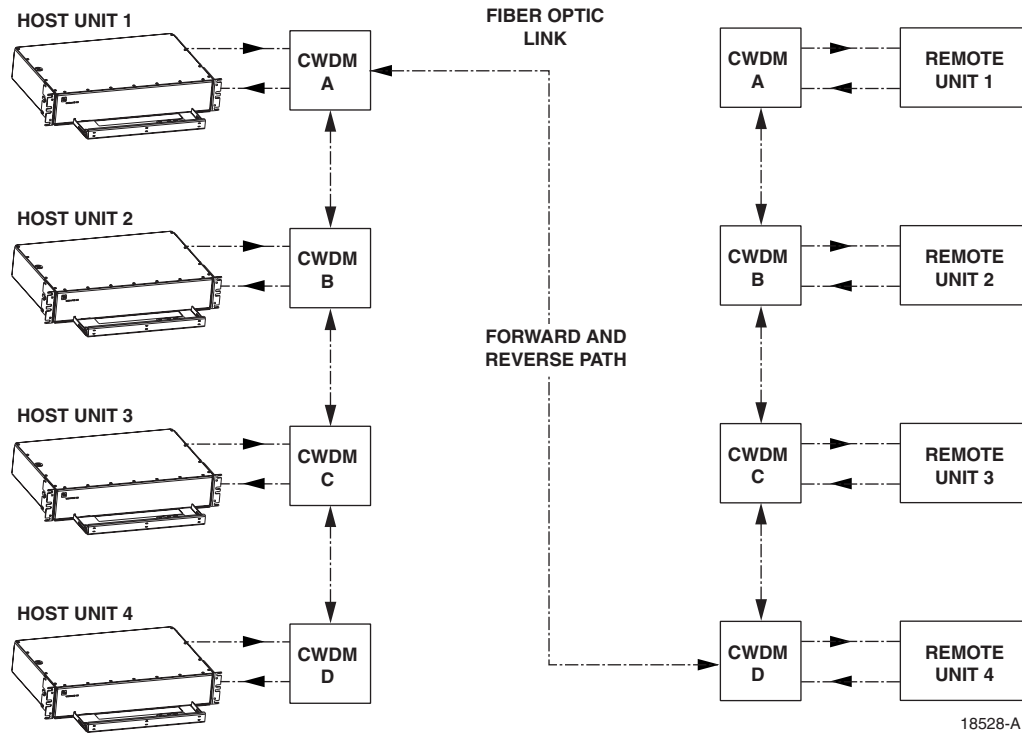

Figure 1-9. Coarse Wavelength Division Multiplexer Application

A Free Space Optics (FSO) system (that meets the Digivance LRCS data rate performance and BER requirements) may be used in applications where it is desirable or necessary to bridge an open span and where it is impractical to lay a fiber optic cable. One FSO transceiver unit may be mounted on the HU side of the open span and the other FSO transceiver unit may be mounted on the RU side of the open span. A system diagram of an FSO application is shown in Figure 1-10. FSO systems are available from various equipment manufacturers.

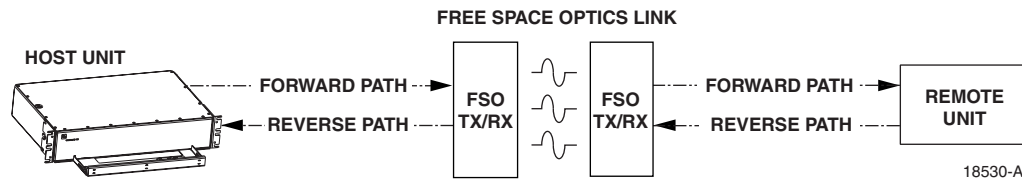

Figure 1-10. Free Space Optics Application

3.2 Control and Monitoring Software

The EMS software and the SNMP Proxy Agent software provide control and monitoring functions for the Digivance system through the local, NOC, and SNMP interfaces. The EMS and SNMP Proxy Agent software are stored on CD-ROM's which are shipped in a separate package along with the software user manuals. The EMS software package is available without the SNMP Proxy Agent if the SNMP interface capability not required for the application. Software installation consists of copying the software files from the CD-ROM's to a designated directory on the hard-drive of the EMS computer.

The EMS software provides the capability to provision and configure the Digivance system for operation. This includes selecting a site name, setting alarm thresholds, and setting forward and reverse path RF gain adjustments. The EMS software also provides the capability to get alarm messages (individual or summary), obtain data measurements, and to upgrade the HU/RU system software. All control and monitor functions (except software upgrade which is not supported by the NOC/NEM and SNMP interfaces and HU/RU pair site number assignment which is not supported by the SNMP interface) may be implemented using the NOC/NEM interface, the SNMP interface, or the EMS software GUI.

3.3 Fault Detection and Alarm Reporting

LED indicators are provided on the front panel of the HU and on the front panels of the RU modules to indicate if the system is normal or if a fault is detected. In addition, normally open and normally closed alarm contacts (for both major and minor alarms) are provided at the HU for connection to a customer-provided external alarm system. All alarms can also be accessed through the NOC/NEM interface, SNMP manager, or the EMS software GUI.

3.4 Powering

The HU is powered by ± 24 or ± 48 VDC and must be hard-wired to a local office battery power source through a fuse panel. A screw-down terminal strip is provided on the rear side of the HU for the power connections.

The RU is powered by 120 or 240 VAC power (50 or 60 Hz) and must be connected to a 20 Amp AC power source. If the RU modules are installed in an outdoor cabinet, the AC wiring is placed in conduit and permanently connected to the internal cabinet wiring. If the RU modules are installed in an indoor mounting shelf, a standard three-conductor AC power cord is provided for connection to a standard AC power outlet. A back-up battery system is available for specified outdoor cabinets as an accessory. The battery-backup system powers the RU if the AC power source is disconnected or fails.

3.5 Equipment Mounting and Configuration

The HU is a single-unit assembly that is designed for mounting in a **non-condensing indoor** environment such as inside a wiring closet or within an environmentally-controlled cabinet. The HU is intended for rack-mount applications and may installed (usually within 20 feet of the EBTS) in either a 19- or 23-inch, WECCO or EIA, equipment rack.

The RU is designed for mounting in either an **indoor or outdoor** environment. The RU consists of a Spectrum Transport Module (STM), a Linear Power Amplifier (LPA) module, WDM remote module (accessory), CWDM remote module (accessory), and either an outdoor cabinet or a indoor mounting shelf.

Several types of outdoor cabinets are available. Each outdoor cabinet is weather-tight but contact with salt-air mist should be avoided as it may degrade the MTBF of the product. Outdoor cabinets can be mounted from a flat-vertical surface or a utility pole (requires pole-mount kit). Slots are provided within each cabinet for mounting the STM and LPA modules and also the WDM or CWDM remote modules. Storage spools are provided within the cabinet for storing short lengths of excess fiber slack. Specified cabinets include a tray with a heated base for mounting a back-up battery (accessory item).

A indoor mounting shelf for indoor use is also available. The indoor mounting shelf is designed for installation in a non-condensing indoor environment such as inside a wiring closet or within an environmentally-controlled cabinet. The indoor mounting shelf installs in a standard EIA or WECCO, 19- or 23-inch, equipment rack. Slots are provided within the mounting shelf for mounting the STM and LPA modules and also the WDM or CWDM remote modules.

SECTION 2: DESCRIPTION

Content	Page
1 INTRODUCTION	2-3
2 HOST UNIT	2-3
2.1 Primary Components	2-3
2.2 Mounting	2-3
2.3 Fault Detection and Alarm Reporting	2-4
2.4 RF Signal Connections	2-4
2.5 RF Signal Level Adjustments	2-5
2.6 Propagation Delay	2-5
2.7 Optical Connection	2-5
2.8 Controller Area Network Interface Connection	2-5
2.9 Service Interface Connection	2-5
2.10 Auxiliary Interface Connector	2-5
2.11 Powering	2-6
2.12 Cooling	2-6
2.13 User Interface	2-6
3 SPECTRUM TRANSPORT MODULE	2-8
3.1 Primary Components	2-8
3.2 Mounting	2-9
3.3 Fault Detection and Alarm Reporting	2-9
3.4 Antenna Cable Connection	2-10
3.5 RF Signal Level Adjustment	2-10
3.6 Optical Connection	2-10
3.7 Service Interface Connection	2-10
3.8 Auxiliary Interface Connection	2-10
3.9 Powering	2-10
3.10 Cooling	2-11
3.11 User Interface	2-11
4 35 WATT LINEAR POWER AMPLIFIER	2-13
4.1 Primary Components	2-13
4.2 Mounting	2-14
4.3 Fault Detection and Alarm Reporting	2-14
4.4 Powering	2-14
4.5 Cooling	2-14
4.6 User Interface	2-14
5 REMOTE UNIT MOUNTING SHELF	2-16
5.1 Indoor Mounting Shelf	2-16
6 SLIM-STYLE REMOTE UNIT CABINETS	2-17
6.1 Slim-Style Single-STM Cabinet	2-18
6.2 Slim-Style Dual-STM Cabinet	2-20
7 ACCESSORY ITEMS	2-23
7.1 Remote Unit Back-up Battery Kit	2-23
7.2 Wavelength Division Multiplexer System	2-24

7.3	Coarse Wavelength Division Multiplexer System	2-25
8	DIGIVANCE ELEMENT MANAGEMENT SYSTEM	2-26
8.1	Digivance EMS Primary Components	2-26
8.2	Software Installation	2-28
8.3	Computer Operation	2-28
8.4	Digivance EMS Computer Interface Connections	2-28
8.5	Digivance EMS User Interfaces	2-29
9	SPECIFICATIONS	2-31

1 INTRODUCTION

This section describes the basic components of a typical Digivance 800/900 MHz SMR LRCS system including the Host Unit (HU) and Remote Unit (RU). The HU consists of a single rack-mount chassis. The RU consists of a Spectrum Transport Module (STM); a 35 Watt Linear Power Amplifier (LPA) module; and either an outdoor cabinet or an indoor mounting shelf. Also described in this section are various accessory items that may be used with the HU and RU including the Wavelength Division Multiplexer (WDM) system, Coarse Wavelength Division Multiplexer (CWDM) system, and RU back-up battery kit.

2 HOST UNIT

The HU, shown in [Figure 2-1](#), provides the following basic functions:

- Provides an adjustable RF interface with the BTS.
- Provides a fiber optic interface with the RU.
- Digitizes the two forward path composite RF signals.
- Converts the two digitized forward path RF signals to a digital optical signal.
- Converts the digitized reverse path optical signal to two digitized RF signals.
- Converts the two digitized reverse path RF signals to two composite RF signals.
- Sends alarm information to an external alarm system through relay contact closures
- Provides an RS-232 interface for connecting the EMS computer.
- Provides an RS-232 interface for an auxiliary communications link with remote equipment.
- Provides a CAN interface for networking multiple HUs.

2.1 Primary Components

The HU consists of an electronic circuit board assembly and a fan assembly that are mounted within a powder-paint coated sheet metal enclosure. The enclosure provides a mounting point for the circuit board and fan assemblies and controls RF emissions. The only user-replaceable component is the fan assembly. The HU is designed for use within a non-condensing indoor environment such as inside a wiring closet or cabinet. The RF connectors, optical connectors, alarm output connectors, DC power terminal strip, and grounding lug are mounted on the HU rear panel. The On/Off power switch, LED indicators, service interface connector, and Controller Area Network (CAN) connectors are mounted on the HU front panel.

2.2 Mounting

The HU is intended for rack-mount applications. A pair of reversible mounting brackets is provided that allow the HU to be mounted in either a 19-inch or 23-inch EIA or WECO equipment rack. When installed, the front panel of the HU is flush with the front of the rack. Screws are provided for securing the HU to the equipment rack.

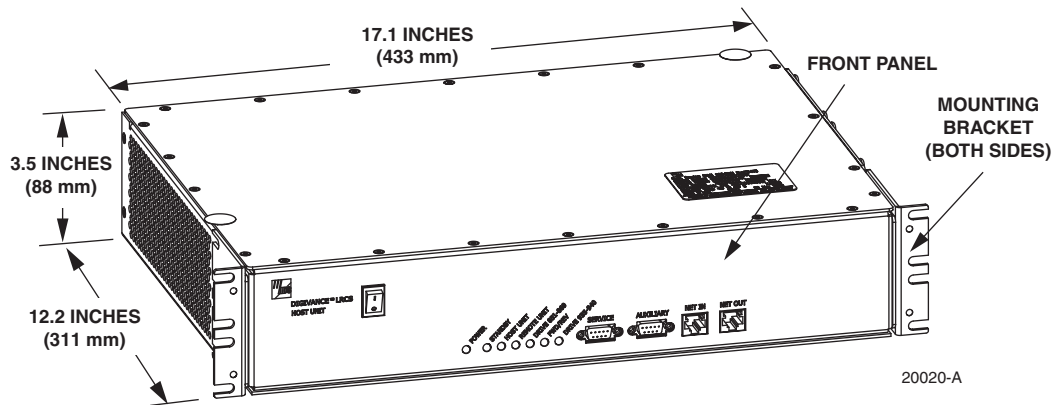

Figure 2-1. Host Unit

2.3 Fault Detection and Alarm Reporting

The HU detects and reports various internal and external faults including host unit fault, optical fault, power fault, temperature fault, and RF fault. Various front panel Light Emitting Diode (LED) indicators turn from green to red or yellow if a fault is detected. A set of alarm contacts (normally open and normally closed) are provided for reporting an alarm to an external alarm system when a fault is detected. Both major alarm (system operation seriously affected) and minor alarm (system operation not affected or only slightly degraded) contacts are provided.

Fault and alarm information may also be accessed locally through the EMS software GUI or remotely through the NOC/NEM interface or SNMP interface. An alarm history file is maintained by the EMS software so that a record is kept of all alarms as they occur. This is useful when an alarm is reported and cleared before the reason for the alarm can be determined.

The status of the HU, the alarm state (major or minor), and other alarm information is summarized and reported over the service interface, the CAN interface, and the optical interface to the RU. In addition, the status of the RU is transmitted to the HU over the optical interface and reported over the service interface and the CAN interface.

2.4 RF Signal Connections

The RF signal connections between the HU and the EBTS are supported through four N-type female connectors. Two connectors are used for the forward path RF signals. The other two connectors are used for the reverse path RF signals. In most installations, it is usually necessary to install external attenuators to support the RF interface between the HU and the EBTS. The HU should be as close as possible to the EBTS to minimize coaxial cable losses.

2.5 RF Signal Level Adjustments

The HU is equipped with several attenuators for adjusting the signal levels of the forward and reverse path RF signals. The attenuators provide an attenuation adjustment range of 0 to 31 dB and can be set in 1 dB increments. The attenuators are software controlled and are adjusted through the EMS software GUI, NOC/NEM interface, or SNMP interface.

The **host forward path** attenuators adjust the level of the two **input** RF signals to the HU. Using the forward path attenuator, an input signal with a nominal composite signal level of -12 dBm to -43 dBm can be adjusted to produce maximum power output. **Additional external attenuation is required if the input signal level is greater than -12 dBm.**

The **host reverse path** attenuators adjust the level of the two **output** RF signals from the HU and will add from -1 dB of gain (attenuator set to 31 dB) to $+30$ dB of gain (attenuator set to 0 dB) to the two RF output signals at the HU.

2.6 Propagation Delay

The HU forward and reverse path propagation delays may be adjusted in 0.1 μ sec increments within a range of 0 to 63 μ s. The propagation delay is software controlled and may be adjusted through the EMS software GUI, NOC/NEM interface, or SNMP interface.

2.7 Optical Connection

Optical connections between the HU and the RU (STM) are supported through two SC-type optical connector ports. One port is used for the forward path optical signal connection and the other port is used for the reverse path optical signal connection.

2.8 Controller Area Network Interface Connection

Controller Area Network (CAN) interface connections between multiple HUs are supported by a pair of RJ-45 jacks. One of the jacks is designated as the network IN port and the other jack is designated as the network OUT port. The CAN interface allows up to 24 HUs to be connected together (in daisy-chain fashion) and controlled through a single EMS computer.

2.9 Service Interface Connection

The service interface connection between the HU and the EMS computer is supported by a single DB-9 female connector. The service connector provides an RS-232 DTE interface. When multiple HUs are networked together, the supporting EMS computer may be connected to the service connector of any one of the networked HUs.

2.10 Auxiliary Interface Connector

An auxiliary communication link is provided between the HU and the STM for customer use. The auxiliary interface is supported by a single DB-9 female connector. The auxiliary connector provides an RS-232 DTE interface. The auxiliary communications link can be used to remotely monitor and control other network equipment that may be located at the remote unit site such as the antenna.

2.11 Powering

The HU is powered by ± 21 to ± 60 VDC power (nominal ± 24 or ± 48 VDC). The power is fed to the HU through a screw-down type terminal strip located on the rear side of the unit. Power to the HU must be supplied through a fuse panel such as the PowerWorx GMT Series Fuse Panel (available separately). The power circuit for each HU must be protected with a 3 Amp GMT fuse. An On/Off switch is provided on the HU front panel.

2.12 Cooling

Continuous airflow for cooling is provided by dual fans mounted on the right side of the HU housing. A minimum of 3 inches (76 mm) of clearance space must be provided on both the left and right sides of the HU for air intake and exhaust. An alarm is generated if a high temperature condition ($>50^{\circ}\text{C}/122^{\circ}\text{F}$) occurs. The fans may be field-replaced if either fan fails.

2.13 User Interface

The HU user interface consists of the various connectors, switches, terminals, and LEDs that are provided on the HU front and rear panels. The HU user interface points are indicated in [Figure 2-2](#) and described in [Table 2-1](#).

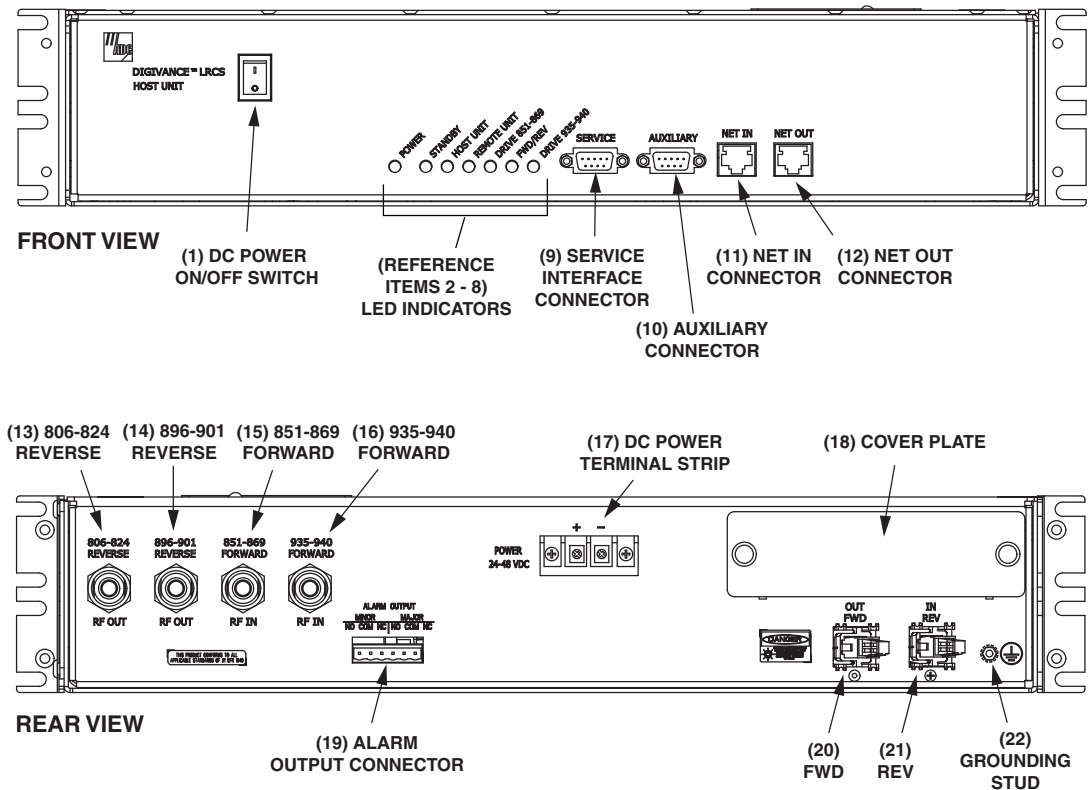

20021-A

Figure 2-2. Typical Host Unit User Interface

Table 2-1. Host Unit User Interface

REF NO	USER INTERFACE DESIGNATION	DEVICE	FUNCTIONAL DESCRIPTION
1	I/O	On/Off rocker switch	Provides DC power on/off control.
2	POWER	Multi-colored LED (green/yellow)	Indicates if the HU is powered (green) or unpowered (off). See Note.
3	STANDBY	Multi-colored LED (green/yellow/red)	Indicates if the system is in the Normal (off), Standby (blinking green), Test (blinking red), or Program Load (blinking yellow) state. See Note.
4	HOST UNIT	Multi-colored LED (green/yellow/red)	Indicates if the HU is normal (green), overheated (yellow), or faulty (red). See Note.
5	REMOTE UNIT	Multi-colored LED (green/yellow/red)	Indicates if no alarms (green), a minor alarm (yellow), or a major alarm (red) is reported by the RU. See Note.
6	DRIVE 851–869	Multi-colored LED (green/yellow/red)	Indicates if the level of the 851–869 MHz RF input signal to the HU is normal (green), low (yellow), or high (red). See Note.
7	FWD/REV (PORT 1/PORT 2)	Multi-colored LED (green/red)	Indicates if the reverse/forward path optical signals from the STM/HU are normal (green), if no signals are detected (red), or if excessive errors are detected (red). See Note.
8	DRIVE 935–940	Multi-colored LED (green/yellow/red)	Indicates if the level of the 935–940 MHz RF input signal to the HU is normal (green), low (yellow), or high (red). See Note.
9	SERVICE	DB-9 connector (female)	Connection point for the RS-232 service interface cable.
10	AUXILIARY	DB-9 connector (female)	Connection point for the RS-232 auxiliary interface cable.
11	NET IN	RJ-45 jack (female)	Connection point for the CAN interface input cable.
12	NET OUT	RJ-45 jack (female)	Connection point for the CAN interface output cable.
13	806–824 REVERSE	N-type female RF coaxial connector	Output connection point for the 806–824 MHz reverse path RF coaxial cable.
14	896–901 REVERSE	N-type female RF coaxial connector	Output connection point for the 896–901 MHz reverse path RF coaxial cable.
15	851–869 FORWARD	N-type female RF coaxial connector	Input connection point for the 851–869 MHz forward path RF coaxial cable.
16	935–940 FORWARD	N-type female RF coaxial connector	Input connection point for the 935–940 MHz forward path RF coaxial cable.
17	POWER 24–48 VDC	Screw-type terminal strip	Connection point for the DC power wiring.
18	No designation	Cover plate	Covers the mounting slot for the wavelength division multiplexer module.

Table 2-1. Host Unit User Interface, continued

REF NO	USER INTERFACE DESIGNATION	DEVICE	FUNCTIONAL DESCRIPTION
19	ALARM OUTPUT	Screw-type terminal connector (14–26 AWG)	Connection point for an external alarm system. Includes normally open (NO), normally closed (NC), and common (COM) wiring connections.
20	FWD (PORT 1)	SC connector (single-mode)	Output connection point for the forward path optical fiber.
21	REV (PORT 2)	SC connector (single-mode)	Input connection point for the reverse path primary optical fiber.
22		Chassis ground stud	Connection point for a chassis grounding wire.
Note: A more detailed description of LED operation is provided in Section 4.			

3 SPECTRUM TRANSPORT MODULE

The STM, shown in [Figure 2-3](#), provides the following basic functions:

- Provides an RF interface (antenna port) for the remote antenna(s).
- Provides an optical interface for the HU.
- Converts the digitized forward path optical signal to digitized RF signals.
- Converts the digitized forward path RF signals to two composite RF signals.
- Digitizes the two reverse path composite RF signals.
- Converts the digitized reverse path RF signals to a digitized optical signal.
- Provides an RS-232 interface for connecting a local EMS computer.
- Provides an RS-232 interface for an auxiliary communications link with remote equipment.
- Transports alarm, control, and monitoring information to the HU via the optical interface.
- Accepts AC power input and battery power input.
- Accepts external alarm input.

3.1 Primary Components

The STM consists of an electronic circuit board assembly, power supply, quadplexer, and fan assembly that are mounted within a powder-paint coated sheet metal enclosure. The metal enclosure provides a mounting point for the electronic components and controls RF emissions. Except for the fan unit, the electronic components are not user replaceable. The STM is designed for use within the RU outdoor cabinet or indoor mounting shelf. Except for the LPA interface connector, all controls, connectors, indicators, and switches are mounted on the STM front panel for easy access. A carrying handle is provided on the front of the STM to facilitate installation and transport.

3.2 Mounting

The STM mounts within the RU outdoor cabinet or indoor mounting shelf. Runners on the top and bottom of the STM mesh with tracks in the cabinet or mounting shelf. The runners and tracks guide the STM into the installed position. The electrical interface between the STM and LPA is supported by a D-sub female connector located on the rear side of the STM. A corresponding D-sub male connector mounted at the rear of the RU cabinet or indoor mounting shelf mates with the STM connector. Captive screws are provided for securing the STM in the installed position.

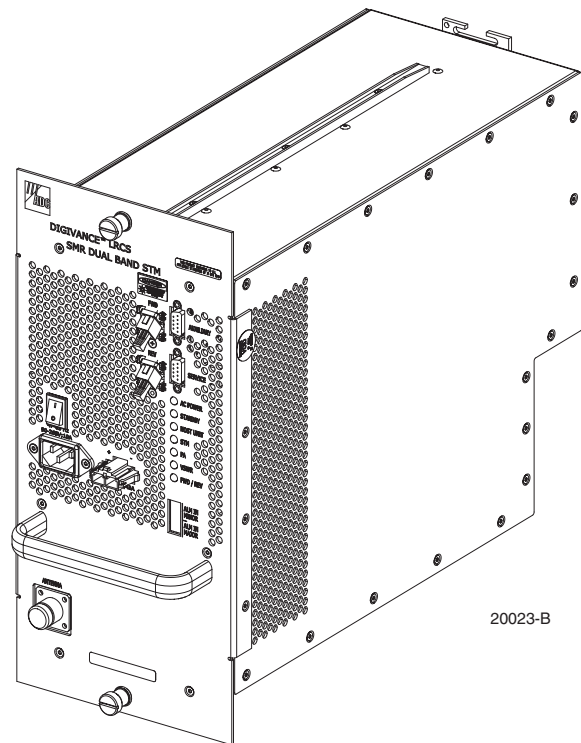

Figure 2-3. Typical Spectrum Transport Module

3.3 Fault Detection and Alarm Reporting

The STM detects and reports various faults including remote unit fault, optical fault, power fault, temperature fault, power amplifier fault, and external (cabinet door open) fault. Various front panel Light Emitting Diode (LED) indicators turn from green to red or yellow if a fault is detected. The status of the STM, the alarm state (major or minor), and other alarm information is summarized and reported over the optical interface to the HU and also over the service interface. In addition, the alarm state of the HU is received over the optical interface and reported to the service interface. Fault and alarm information may be accessed locally through the EMS software GUI or remotely through the NOC/NEM interface or SNMP interface.

3.4 Antenna Cable Connection

The antenna cable connection between the STM and the antenna is supported through a single N-type female connector. The single connector is used for the antenna cable which carries both the forward and primary reverse path RF signals.

3.5 RF Signal Level Adjustment

The STM is equipped with digital attenuators for adjusting the signal level of the forward path RF **output** signals. The **remote forward path** attenuators adjust the level of the two output RF signals at the RU antenna port and will add from 0 to 31 dB of attenuation to the output signal level. The attenuator can be set in 1 dB increments. The attenuator is software controlled and is adjusted through the EMS software GUI, the NOC/NEM interface, or SNMP interface.

3.6 Optical Connection

Fiber optic connections between the STM and the HU are supported through two SC-type optical connector ports. One port is used for the forward path optical signal connection and the other port is used for the reverse path optical signal connection.

3.7 Service Interface Connection

The service interface connection between the STM and a local laptop computer loaded with the EMS software is supported by a single DB-9 female connector. The service interface connector provides an RS-232 DTE interface. The STM service interface supports local communications with both the STM and the corresponding HU.

3.8 Auxiliary Interface Connection

An auxiliary communication link is provided between the HU and the STM for customer use. The auxiliary interface is supported by a single DB-9 female connector. The auxiliary connector provides an RS-232 DTE interface. The auxiliary communications link can be used to remotely monitor and control other network equipment that may be located at the remote unit site such as the antenna.

3.9 Powering

The STM is powered by 120 or 240 VAC (50 or 60 Hz) power which is supplied through a three-conductor AC power cord. The power cord is provided with the RU outdoor cabinet or indoor mounting shelf. The power cord connects to a 3-wire AC connector mounted on the front panel. A switch on the STM front panel provides AC power On/Off control.

The STM (and the connected LPA) may be powered by a 24 VDC back-up battery system which is available as an accessory kit. A connector is provided on the STM front panel for the back-up battery system wiring harness connection.

3.10 Cooling

Continuous air-flow for cooling is provided by a single fan mounted on the rear side of the STM housing. An alarm is generated if a high temperature condition (>50° C/122° F) occurs. If the temperature falls below 32° F (0° C), the fan automatically shuts off. The fan may be field replaced if it fails.

3.11 User Interface

The STM user interface consists of the various connectors, switches, and LEDs that are provided on the STM front panel. The STM user interface points are indicated in [Figure 2-4](#) and described in [Table 2-2](#).

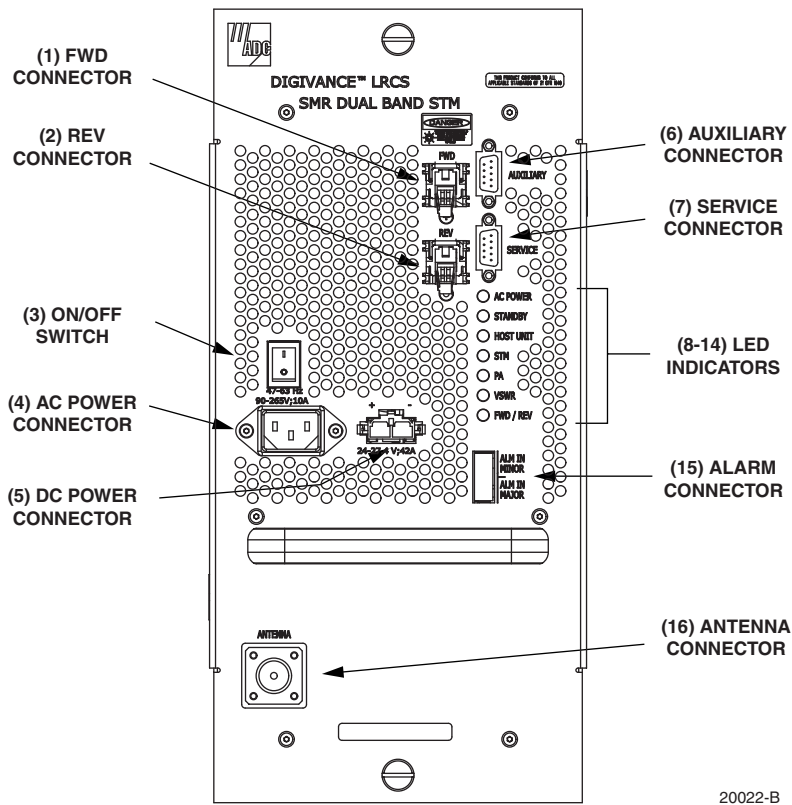

Figure 2-4. Typical Spectrum Transport Module User Interface