

**FLY**  
3 WATT MINI AMP

# SET-UP GUIDE



**Congratulations on buying this Blackstar FLY Bluetooth mini amplifier**

Your FLY 3 is a compact, innovative mini amp with big TONE. Combining two channels, our patented Infinite Shape Feature (ISF) and a tape delay together with Bluetooth connectivity, it's the perfect take-anywhere amp.

## GETTING STARTED

### 1. BATTERY TAB

Pull out the tab located at the rear of your FLY 3 to activate the batteries.

Retirer la languette située à l'arrière de votre FLY 3 pour activer les batteries.

本体背面にある絶縁タブを引き抜いてください。液漏れを防ぐため、長期間使用しない場合はバッテリーを本体から取り外してください。

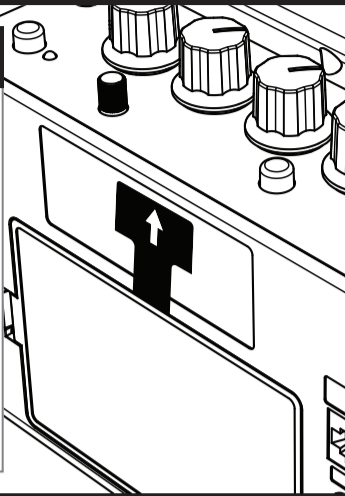

### 2. INPUT

Plug your guitar lead into the Input socket.

Branchez votre câble de guitare dans le port "Input".

インプット・ソケットにお使いのシールドケーブルを差し込んでください。

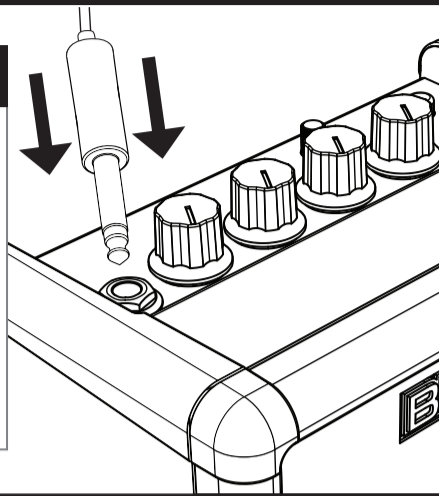

### 3. POWER

Switch your amplifier on using the Power Switch.

Mettez l'amplificateur sous tension grâce à l'interrupteur.

パワースイッチを押して、本体の電源をオンしてください。

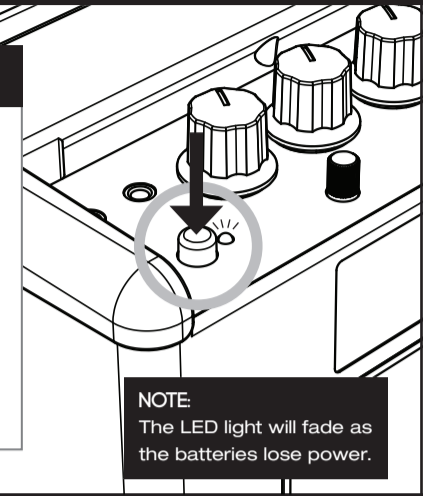

**NOTE:**  
The LED light will fade as the batteries lose power.

## SETTING UP

### 1. CLEAN OR OVERDRIVE

Press the OD switch in to select the Overdrive channel — when the switch is out, the Clean channel is in operation.

Quand le commutateur OD est en position haute le canal clean est sélectionné, quand il est poussé c'est le canal OD qui est activé.

電源を入れた直後は、クリーンチャンネルに設定されています。ODボタンを押すとオーバードライブチャンネルに切り替わります。

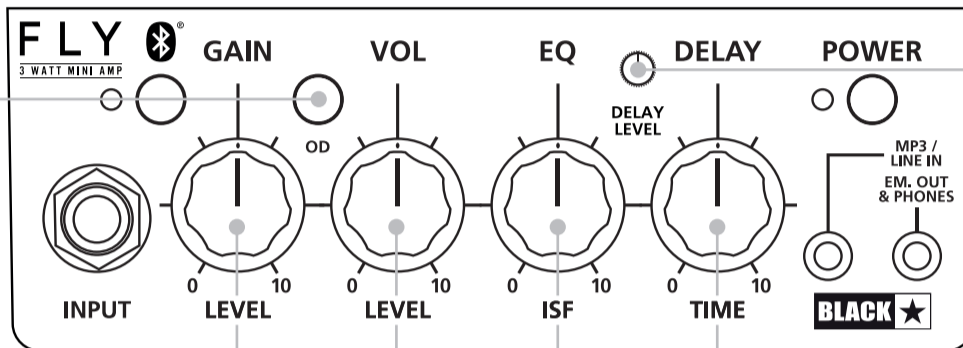

### 3. DELAY LEVEL

The DELAY LEVEL dial changes the volume of the delay effect.

Le bouton DELAY LEVEL change le volume de l'effet delay.

DELAY LEVELのつまみを回すと、ディレイエフェクトのボリューム調整ができます。

### 4. DELAY TIME

The DELAY TIME dial changes the tempo of the delay effect.

Le bouton DELAY TIME change le tempo de l'effet Delay.

TIMEのつまみを回すと、ディレイエフェクトのテンポの調整ができます。

### 2. CHOOSE YOUR SOUND

Set your gain and volume — higher gain settings give you more overdrive (distortion). Blend your EQ between a UK and American sound, using Blackstar's patented ISF control.

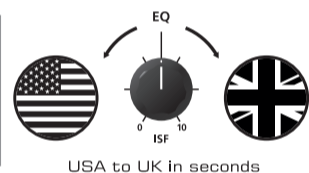

Réglez le gain et le volume. Les réglages de gain élevés produisent davantage de distortion. Le contrôle ISF, breveté Blackstar, permet de passer d'une égalisation type Anglaise (UK) à Américaine (USA).

ゲインとボリュームを調節します。ゲインを高めると歪んだ音になります。EQのISFでアメリカンサウンドからブリティッシュサウンドまで調節できます。

## GET CONNECTED

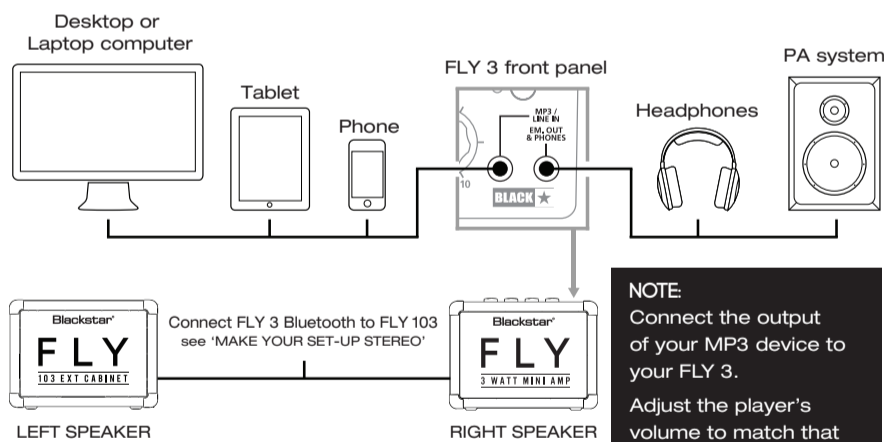

**NOTE:**  
Connect the output of your MP3 device to your FLY 3. Adjust the player's volume to match that of your guitar to enable you to play along.

## BLUETOOTH

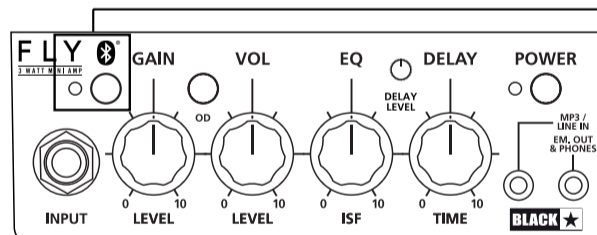

### BLUETOOTH

**DISCOVERABLE MODE (Slow LED flash):** to pair simply go to the devices page of your Bluetooth device, select your FLY Bluetooth, then play your music.

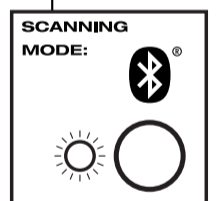
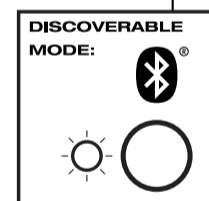

**SCANNING MODE (Fast LED flash):** reconnect automatically to a previously paired device, or press again to enter Discoverable Mode.

**NOTE:** Press and hold bluetooth button for 2 seconds to disconnect the current device.

## BATTERY INFORMATION

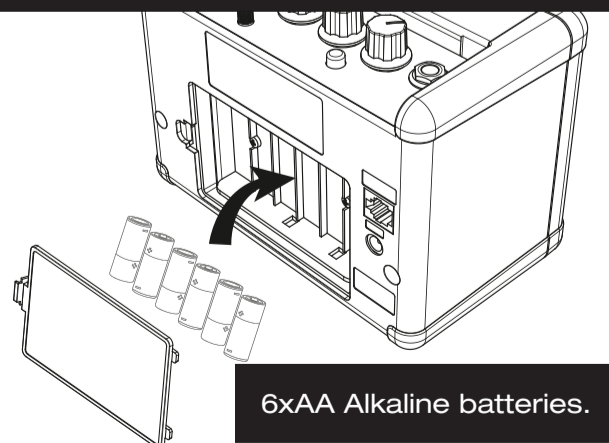

6x AA Alkaline batteries.

6 x AA BATTERIES INCLUDED

## PSU INFORMATION

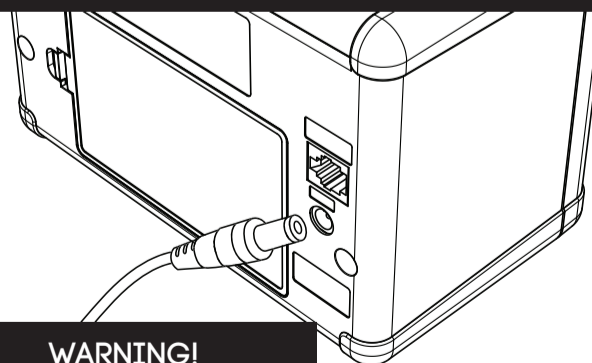

### WARNING!

Only use a Blackstar approved FLY PSU-1 power supply unit.

FLY PSU-1 POWER SUPPLY SOLD SEPARATELY

## MAKE YOUR SET-UP STEREO

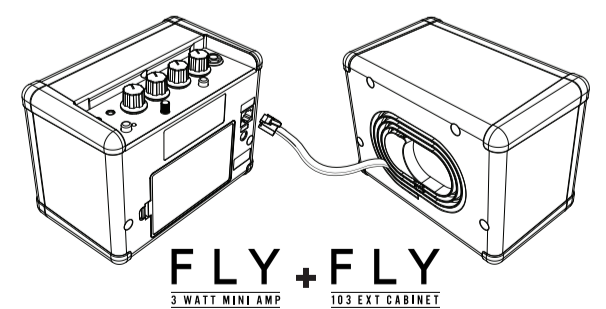

CONNECT TO FLY 103

FLY 103 SOLD SEPARATELY

...ON THE FLY.

DOWNLOAD YOUR FLY 3 BLUETOOTH HANDBOOK

For more information, or to download the full user handbook go to: [www.blackstaramps.com](http://www.blackstaramps.com)

**Blackstar**  
AMPLIFICATION  
the sound in your head

