

# TEST REPORT

## 1. Applicant

**Name** : Handheld Group AB  
**Address** : Kinnegatan 17A S-531 33 Lidköping, Sweden

## 2. Products

**Name** : Mobile Computer  
**Model** : NAUTIZ X4  
**Manufacturer** : POINTMOBILE CO.,LTD

**3. Test Standard** : FCC 47 CFR § 2.1093

**4. Test Method** : IEEE 1528-2003

**5. Test Results** : Positive

**6. Date of Application** : January 16, 2014

**7. Date of Issue** : June 20, 2014

Tested by



Jong-gon Ban  
ICT Infrastructure  
Technology Center  
Senior Engineer

Approved by

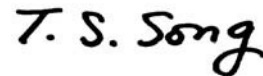

Tae-Seung Song  
ICT Infrastructure  
Technology Center  
Manager

*The test results contained apply only to the test sample(s) supplied by the applicant, and this test report shall not be reproduced in full or in part without approval of the KTL in advance.*

## Korea Testing Laboratory

**Test Report revision History**

Revision	Date	Comments
00	2014-06-20	Initial Version

## TABLE OF CONTENTS

<b>1. ADMINISTRATIVE INFORMATION.....</b>	<b>5</b>
1.1. Applicant Data .....	5
1.2. Manufacturer Data (only if different from Applicant) .....	5
1.3. Testing Laboratory Data .....	5
<b>2. EUT INFORMATION.....</b>	<b>6</b>
2.1. General Description of the EUT .....	6
2.2. SAR Results Summaries .....	6
<b>3. SAR DEFINITION .....</b>	<b>7</b>
<b>4. TEST METHODOLOGY .....</b>	<b>7</b>
<b>5. DESCRIPTION OF SAR MEASUREMENT SYSTEM .....</b>	<b>8</b>
<b>6. SYSTEM VERIFICATION .....</b>	<b>9</b>
6.1. Tissue Simulating Mixture Characterization .....	9
6.2. Tissue Verification .....	10
6.3. System Validation .....	12
<b>7. SAR MEASUREMENT PROCEDURE USING DASY4 .....</b>	<b>13</b>
<b>8. DESCRIPTION OF TEST POSITION .....</b>	<b>15</b>
8.1. Cheek Position .....	15
8.2. Tilt Position.....	16
8.3. Body Holster/ Belt Clip Configurations .....	17
<b>9. MEASUREMENT UNCERTAINTY .....</b>	<b>18</b>
<b>10. FCC RF EXPOSURE LIMITS .....</b>	<b>19</b>
<b>11. RF CONDUCTED POWERS .....</b>	<b>20</b>
11.1. Nominal and Maximum Output Power Specifications .....	20
11.2. SAR scaling factors sample calculation.....	20
11.3. GSM/GPRS/EDGE Conducted output Power Measurements .....	21

11.4. GSM/GPRS/EDGE Conducted output Powers .....	22
11.5. UMTS Conducted output Power Measurements.....	23
11.6. UMTS Conducted output Powers .....	25
11.7. 802.11b/g/n (2.4GHz) Conducted Output Powers .....	26
11.8. Bluetooth Conducted Output Powers.....	27
<b>12. SAR TEST CONDITIONS &amp; ANTENNA INFORMATION .....</b>	<b>28</b>
12.1. Standalone SAR Measurements.....	28
12.2. Simultaneous SAR Measurements.....	28
12.3. Antenna Information.....	28
<b>13. SAR MEASUREMENT RESULTS.....</b>	<b>29</b>
13.1. GSM850 SAR Measurement Results .....	29
13.2. GSM1900 SAR Measurement Results.....	29
13.3. UMTS850 SAR Measurement Results .....	30
13.4. UMTS1900 SAR Measurement Results.....	30
13.5. WLAN (2.4GHz) SAR Measurements Results.....	31
13.6. SAR Test Notes .....	32
<b>14. FCC MULTI-TX CONSIDERATION .....</b>	<b>34</b>
14.1. Introduction .....	34
14.2. Simultaneous Transmission Procedures .....	34
14.3. Head & Body SAR Simultaneous Transmission Analysis .....	34
<b>15. SAR MEASUREMENT VARIABILITY .....</b>	<b>35</b>
15.1. Measurement Variability.....	35
15.2. Measurement Uncertainty .....	35
<b>16. CONCLUSION.....</b>	<b>36</b>
<b>17. EQUIPMENT LIST AND CALIBRATION DETAILS.....</b>	<b>37</b>
APPENDIX A. SAR PLOTS	
APPENDIX B. SAR MEASUREMENT SETUP PHOTOS	
APPENDIX C. CALIBRATION DATA SHEETS	

# 1. Administrative Information

## 1.1. Applicant Data

<b>Company Name</b>	<b>Handheld Group AB</b>
Address	Kinnegatan 17A S-531 33 Lidköping, Sweden
<b>Contact Person</b>	
Name	Jerker Hellstrom
E-mail	j.hellstrom@handheldgroup.com
Phone	+46(0)510-54 7170

## 1.2. Manufacturer Data (only if different from Applicant)

<b>Company Name</b>	<b>POINTMOBILE CO.,LTD</b>
Address	Gasan-dong, B-9F Kabul Great Valley 32, Digital-ro9-gil, Geumcheon-gu, Seoul, Korea
<b>Contact Person</b>	
Name	Chloe Kim
E-mail	chloe.kim@pointmobile.co.kr
Phone	+82 70 7090 2642

## 1.3. Testing Laboratory Data

The following list shows all places and laboratories involved for test result generation.

<b>Company Name</b>	<b>Korea Testing Laboratory</b>
Address	723 Haean-ro, Sangnok-Gu, Ansan-Si, Gyeonggi-Do, 426-901 KOREA
<b>Contact Person</b>	
Name	Jong-gon Ban
E-mail	banjg@ktl.re.kr
Phone	+82-31-500-0133
Fax	+82-31-500-0149

## 2. EUT Information

### 2.1. General Description of the EUT

The following section lists all specifications of EUT (Equipment Under Test) involved in test. Additionally, KTL has received sufficient documentation from the client and/or manufacturer to perform the tests

General Information		
FCC ID & Model Number		FCC ID: <b>YY3-14244R</b> , Model Number: <b>NAUTIZ X4</b>
SKUs	NX4-2DGQ-R-E	BT, WiFi, GSM, UMTS, RFID, GPS, Camera, 2D scanner, Qwerty Key
	NX4-2DGN-R-E	BT, WiFi, GSM, UMTS, RFID, GPS, Camera, 2D scanner, Numeric Key
S canner/Decode Capabilities		2D engine model: N560X 2D Imager.
GSM Specification		GSM/GPRS/EDGE850/1900, Multi-Slot Class 12
WCDMA Specification		UMTS850/1900
Antenna Type		Internal Antenna
WLAN Specification		802.11 b/g/n (HT20)
WLAN VoIP		Supported
Bluetooth Specification		V2.1+EDR
RFID		NFC 13.56MHz
Mobile Hotspot		Not supported
Battery options		Li-ion, 3.7 V (400mAh)
Device Dimension		Overall (Length x width) : 154 mm x 75 mm Overall Diagonal : 158mm Display Diagonal : 89 mm

### 2.2. SAR Results Summaries

Band & Mode	Tx Frequency	SAR	
		1 g Head (W/kg)	1g Body (W/kg)
GSM/GPRS/EDGE 850	824.2 ~ 848.8 MHz	0.550	0.356
UMTS 850	826.4 ~ 846.6 MHz	0.593	0.406
GSM/GPRS/EDGE 1900	1850.2 ~ 1909.8 MHz	0.103	0.274
UMTS 1900	1852.4 ~ 1907.6 MHz	0.185	0.516
2.4 GHz WLAN	2412 ~ 2462 MHz	0.175	0.128

### 3. SAR DEFINITION

Specific Absorption Rate (SAR) is defined as the time derivative (rate) of the incremental energy (dU) absorbed by (dissipated in) an incremental mass (dm) contained in a volume element (dV) of a given density(p). It is also defined as the rate of RF energy absorption per unit mass at a point in an absorbing body. (see Figure.1)

$$SAR = \frac{d}{dt} \left( \frac{dU}{dm} \right) = \frac{d}{dt} \left( \frac{dU}{p dv} \right)$$

Figure 1 SAR Mathematical Equation

SAR is expressed in units of Watts per Kilogram (W/kg).

$$SAR = \sigma E^2 / \rho$$

Where :

- $\sigma$  = conductivity of the tissue-simulant material (S/m)
- $\rho$  = mass density of the tissue-simulant material (kg/m<sup>3</sup>)
- $E$  = Total RMS electric field strength (V/m)

Note: The primary factors that control rate or energy absorption were found to be the wavelength of the incident field in relations to the dimensions and geometry of the irradiated organism, the orientation of the organism in relation to the polarity of field vectors, the presence of reflecting surfaces, and whether conductive contact is made by the organism with a ground plane.[4]

### 4. TEST METHODOLOGY

The tests documented in this report were performed in accordance with IEEE Standard 1528-2003 and the following published KDB procedures.

- FCC KDB Publication 941225 D01 SAR test for 3G devices v02
- FCC KDB Publication 941225 D03 SAR Test Reduction GSM GPRS EDGE v01
- FCC KDB Publication 447498 D01v05r02 (General SAR Guidance)
- FCC KDB Publication 648474 D04 Handset SAR v01r02
- FCC KDB Publication 865664 D01 SAR measurement 100 MHz to 6 GHz v01r03
- FCC KDB Publication 865664 D02 SAR Reporting v01r01
- October 2013 TCB Workshop Notes (GPRS testing criteria)

## 5. DESCRIPTION OF SAR MEASUREMENT SYSTEM

The DASY4 system used for performing compliance tests consists of the following items:

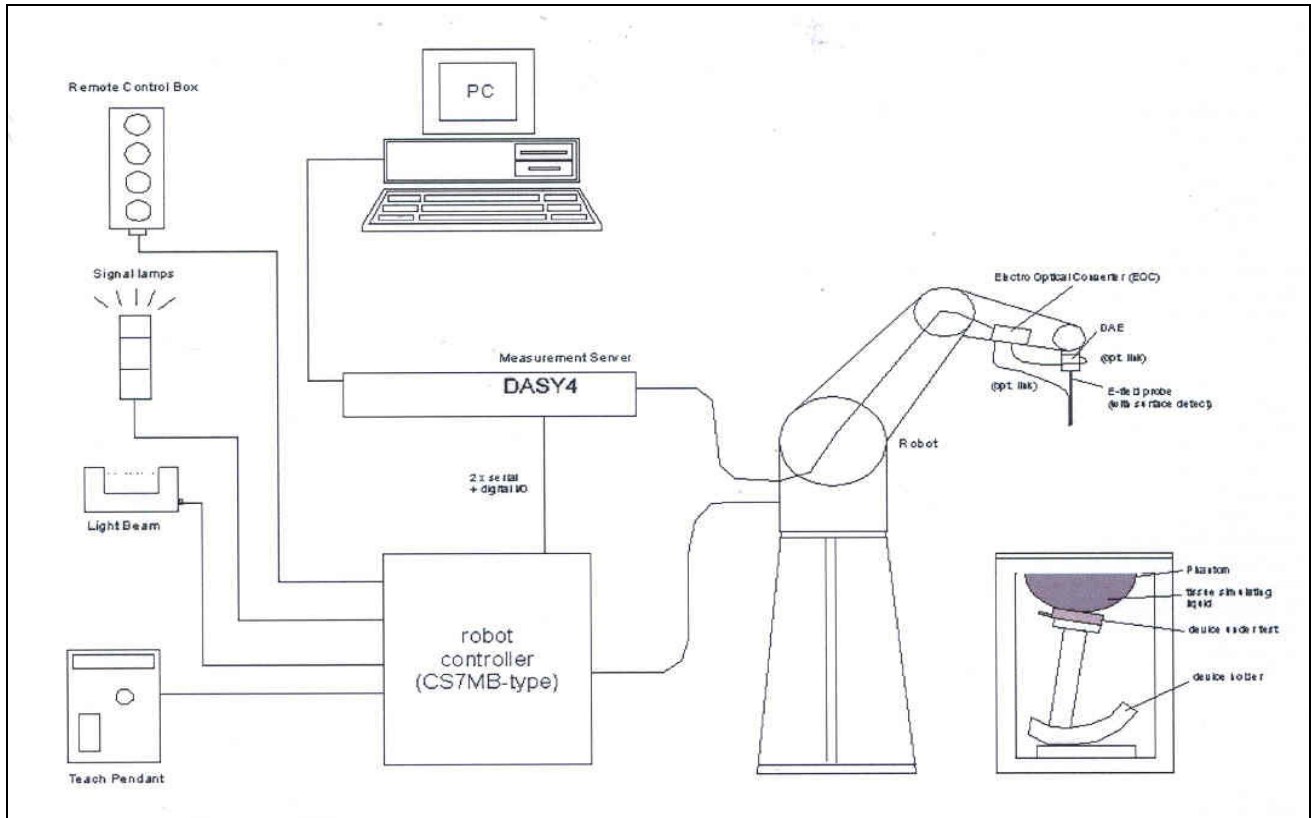

**Figure 2 SAR Measurement System**

- A standard high precision 6-axis robot with controller, teach pendant and software.
- Data acquisition electronics, DAE4 consists of a highly sensitive electrometer-grade preamplifier with auto-zeroing, a channel and gain- switching multiplexer, a fast 16 bit AD-converter and a command decoder and control logic unit.
- Transmission to the PC-card is accomplished through an optical downlink for data and status information and an optical uplink for commands and clock lines.
- The mechanical probe mounting device includes two different sensor systems for frontal and sidewise probe contacts.
- The robot uses its own controller with a built in VME-bus computer. Remote control and teach pendant as well as additional circuitry for robot safety such as warning lamps, etc.
- The phantom, the device holder and other accessories according to the targeted measurement.



## 6. SYSTEM VERIFICATION

### 6.1. Tissue Simulating Mixture Characterization

The mixture is characterized to obtain proper dielectric constant (permittivity) and conductivity of the tissue of interest. The tissue dielectric parameters recommended in IEEE 1528 have been used as targets for the compositions, and are to match within 5%, per the FC recommendations.

Ingredients (% by weight)	Frequency (MHz)							
	835		1900		2450		5200-5800	
Tissue Type	Head	Body	Head	Body	Head	Body	Head	Body
Water	41.45	52.4	54.9	40.4	62.7	73.2	62.52	78.66
Salt (NaCl)	1.45	1.4	0.18	0.5	0.5	0.04	0.0	0.0
Sugar	56.0	45.0	0.0	58.0	0.0	0.0	0.0	0.0
HEC	1.0	1.0	0.0	1.0	0.0	0.0	0.0	0.0
Bactericide	0.1	0.1	0.0	0.1	0.0	0.0	0.0	0.0
Triton X-100	0.0	0.0	0.0	0.0	36.8	0.0	17.24	10.67
DGBE	0.0	0.0	44.92	0.0	0.0	26.7	0.0	0.0
Diethylene glycol hexyl ether	-	-	-	-	-	-	17.24	10.67

**Table 2 Composition of the Tissue Equivalent Materials**

- Salt: 99+% Pure Sodium Chloride Sugar: 98+% Pure Sucrose
- Water: De-ionized, 16 MΩ+ resistivity HEC: Hydroxyethyl Cellulose
- DGBE: 99+% Di(ethylene glycol) butyl ether, [2-(2-butoxyethoxy)ethanol]
- Triton X-100 (ultra pure): Polyethylene glycol mono [4-(1,1, 3, 3-tetramethylbutyl)phenyl]ether

### 6.2. Tissue Verification

The dielectric parameters of the brain and muscle simulating liquid were measured prior to SAR assessment using the HP85070D dielectric probe kit and Agilent 8753D Network Analyzer. The actual dielectric parameters are shown in the following table. The below measured tissue parameters were used in DASY software.

Freq. [MHz]	Liquid	Date	Liquid Temp [°C]	Parameters	Target Value	Measured Value	Dev. (%)	Limit (%)
824.2	Head	05/12/2014	22.3	$\epsilon_r$ $\sigma$	41.5 0.90	42.4	+2.2	± 5
						0.88	-2.2	
836.6		02/21/2014	22.5			42.2	+1.7	
						0.91	+1.1	
848.8		05/12/2014	22.3			41.9	+1.0	
						0.93	+3.3	
826.4		05/12/2014	22.3			42.1	+1.4	
						0.91	+1.1	
835		02/21/2014	22.5			42.2	+1.7	
						0.91	+1.1	
835	05/12/2014	22.3	42.1	+1.4				
			0.91	+1.1				
846.6	05/12/2014	22.3	42.1	+1.4				
			0.93	+3.3				
824.2	Body	05/12/2014	22.6	$\epsilon_r$ $\sigma$	55.2 0.97	53.7	-2.7	± 5
						0.91	+1.0	
836.6		05/12/2014	22.6			53.8	-2.5	
						0.93	-4.1	
848.8		05/12/2014	22.6			53.8	-2.5	
						0.93	-4.1	
826.4		05/12/2014	22.6			53.6	-2.9	
						0.93	-4.1	
835		05/12/2014	22.6			53.7	-2.7	
						0.93	-4.1	
846.6	05/12/2014	22.6	53.8	-2.5				
			0.93	-4.1				
1850.2	Head	05/13/2014	22.5	$\epsilon_r$ $\sigma$	40.0 1.40	39.6	-1.0	± 5
						1.34	-4.2	
1880.0		02/24/2014	22.3			39.3	-1.8	
						1.38	-1.4	
1900		02/24/2014	22.3			39.3	-1.8	
						1.38	-1.4	
1900		05/13/2014	22.5			39.4	-1.5	
						1.37	-2.2	
1909.8		05/13/2014	22.5			39.1	-2.3	
						1.38	-1.4	
1850.2	05/13/2014	22.5	39.6	-1.0				
			1.34	-4.2				
1880	02/24/2014	22.3	39.3	-1.8				
			1.38	-1.4				
1909.8	05/13/2014	22.5	39.1	-2.3				
			1.38	-1.4				
1850.2	Body	05/13/2014	22.2	$\epsilon_r$ $\sigma$	53.3 1.52	51.7	-3.0	± 5
						1.53	+0.7	
1880.0		02/25/2014	22.2			53.0	-0.6	
						1.53	+0.7	
1900	02/25/2014	22.2	53.0	-0.6				
			1.53	+0.7				

1900		05/13/2014	22.2			52.9	-0.8	
1909.8		05/13/2014	22.2			1.53	+0.7	
1850.2		05/13/2014	22.2			51.8	-2.8	
1880		02/25/2014	22.2			1.56	+2.6	
1909.8		05/13/2014	22.2			51.7	-3.0	
						1.53	+0.7	
						53.0	-0.6	
						1.53	+0.7	
2412	Head	05/14/2014	22.5	$\epsilon_r$ $\sigma$	39.2 1.80	38.7	-1.3	$\pm 5$
2437		02/27/2014	22.6			1.82	+1.0	
2450		02/27/2014	22.6			38.7	-1.3	
2450		05/14/2014	22.5			1.86	+3.3	
2462		05/14/2014	22.5			38.7	-1.3	
						1.86	+3.3	
						38.8	-1.1	
						1.86	+3.3	
2412	Body	05/14/2014	23.1	$\epsilon_r$ $\sigma$	52.7 1.95	52.1	-1.1	$\pm 5$
2437		02/28/2014	22.8			1.91	-2.1	
2450		02/28/2014	22.8			52.2	-1.0	
2450		05/14/2014	23.1			1.92	-1.5	
2462		05/14/2014	23.1			52.2	-1.0	
						1.92	-1.5	
						52.2	-1.0	
						1.91	-2.1	
			52.3	-0.8				
			1.91	-2.1				

**Table 3 Measured Simulating Liquid Dielectric Values**

The humidity and dielectric/ambient temperatures are recorded during the assessment of the tissue material dielectric parameters. The difference between the ambient temperature of the liquid during the dielectric measurement and the temperature during tests was less than  $|2|^\circ\text{C}$ .

### 6.3. System Validation

Prior to the SAR assessment, the system validation kit was used to verify that the DASY4 was operating within its specifications. The validation dipoles are highly symmetric and matched at the centre frequency for the specified liquid and distance to the phantom. The accurate distance between the liquid surface and the dipole centre is achieved with a distance holder that snaps onto the dipole. System validation is performed by feeding a known power level into a reference dipole, set at a known distance from the phantom. The measured SAR is compared to the theoretically derived level.

The same SAR probe(s) and tissue-equivalent media combinations used with each specific SAR system for system verification must be used for device testing. When multiple probe calibration points are required to cover substantially large transmission bands, independent system verifications are required for each probe calibration point. A system verification must be performed before each series of SAR measurements using the same probe calibration point and tissue-equivalent medium. Additional system verification should be considered according to the conditions of the tissue-equivalent medium and measured tissue dielectric parameters typically every three to four days when the liquid parameters are re-measured or sooner when marginal liquid parameters are used at the beginning of a series of measurements.

The measured 1g(10g) SAR should be within 10 % of the expected target reference values at the time of calibration by the calibration facility.

Tissue Frequency (MHz)	Tissue Type	Date	Probe SN	Dipole SN	Measured SAR 1g (W/kg)	Target SAR 1g (W/kg)	Deviation (%)	Limit (%)
835	Head	02/21/2014	3972	481	10.28	9.84	+4.5	±10
835	Head	05/12/2014	3020	481	10.36		+5.3	
835	Body	05/12/2014	3020	481	10.32	10.0	+3.2	±10
1900	Head	02/24/2014	3972	5d038	39.56	40.4	-2.1	±10
1900	Head	05/13/2014	3020	5d038	42.8		+5.9	
1900	Body	02/25/2014	3972	5d038	44.0	40.8	+7.3	±10
1900	Body	05/13/2014	3020	5d038	40.4		-1.0	
2450	Head	02/27/2014	3972	746	54.4	52.8	+2.9	±10
2450	Head	05/14/2014	3020	746	53.6		+1.5	
2450	Body	02/28/2014	3972	746	53.2	50.0	+6.4	±10
2450	Body	05/14/2014	3020	746	52.8		+5.6	

**Table 4 Deviation from Reference Validation Values**

## 7. SAR MEASUREMENT PROCEDURE USING DASY4

The SAR evaluation is performed with the SPEAG DASY4 system as following;

### Step 1: Power Reference Measurement

A measurement of the SAR value at a fixed location is used as a reference value for assessing the power drop of the EUT. The SAR at this point is measured at the start of the test and then again at the end of the test.

### Step 2: Area Scan

The Area Scan is used as a fast scan in two dimensions to find the area of high field values, before doing a fine scanning measurement around the hot spot. The sophisticated interpolation routines implemented in DASY software can find the maximum locations even in relatively coarse grids. When an Area Scan has measured all reachable points, it computes the field maximal found in the scanned area, within a range of the global maximum. The range (in dB) is specified in the standards for compliance testing. For example, a 2dB range is required in IEEE Standards 1528 and IEC 62209 standards. If only one Zoom Scan follows the Area Scan, then only the absolute maximum will be taken as reference. For cases where multiple maximums are detected, the number of Zoom Scans has to be increased accordingly.

Area Scan Parameters are as below table from KDB 865664 D01 SAR Measurement 100MHz to 6GHz v01r01.

	$\leq 3$ GHz	$> 3$ GHz
Maximum distance from closest measurement point (geometric center of probe sensors) to phantom surface	$5 \pm 1$ mm	$\frac{1}{2} \cdot \delta \cdot \ln(2) \pm 0.5$ mm
Maximum probe angle from probe axis to phantom surface normal at the measurement location	$30^\circ \pm 1^\circ$	$20^\circ \pm 1^\circ$
Maximum area scan spatial resolution: $\Delta x_{Area}, \Delta y_{Area}$	$\leq 2$ GHz: $\leq 15$ mm 2 – 3 GHz: $\leq 12$ mm	3 – 4 GHz: $\leq 12$ mm 4 – 6 GHz: $\leq 10$ mm
	When the x or y dimension of the test device, in the measurement plane orientation, is smaller than the above, the measurement resolution must be $\leq$ the corresponding x or y dimension of the test device with at least one measurement point on the test device.	

### Step 3: Zoom Scan

Zoom Scans are used to assess the peak spatial SAR values within a cubic averaging volume containing 1g and 10g of simulated tissue. The Zoom Scan measures points (refer to table below) within a cube whose base faces are centered on the maxima found in a preceding area scan job within the same procedure. When the measurement is done, the Zoom Scan evaluates the averaged SAR for 1g and 10g and displays these values next to the job's label.

Zoom Scan Parameters are as below table from KDB 865664 D01 SAR Measurement 100MHz to 6GHz v01r01.

Maximum zoom scan spatial resolution: $\Delta x_{Zoom}$ , $\Delta y_{Zoom}$		$\leq 2$ GHz: $\leq 8$ mm 2 – 3 GHz: $\leq 5$ mm*	3 – 4 GHz: $\leq 5$ mm* 4 – 6 GHz: $\leq 4$ mm*
Maximum zoom scan spatial resolution, normal to phantom surface	uniform grid: $\Delta z_{Zoom}(n)$	$\leq 5$ mm	3 – 4 GHz: $\leq 4$ mm 4 – 5 GHz: $\leq 3$ mm 5 – 6 GHz: $\leq 2$ mm
	graded grid	$\Delta z_{Zoom}(1)$ : between 1 <sup>st</sup> two points closest to phantom surface	$\leq 4$ mm
		$\Delta z_{Zoom}(n>1)$ : between subsequent points	$\leq 1.5 \cdot \Delta z_{Zoom}(n-1)$
Minimum zoom scan volume	x, y, z	$\geq 30$ mm	3 – 4 GHz: $\geq 28$ mm 4 – 5 GHz: $\geq 25$ mm 5 – 6 GHz: $\geq 22$ mm
Note: $\delta$ is the penetration depth of a plane-wave at normal incidence to the tissue medium; see draft standard IEEE P1528-2011 for details. * When zoom scan is required and the <i>reported</i> SAR from the <i>area scan based 1-g SAR estimation</i> procedures of KDB 447498 is $\leq 1.4$ W/kg, $\leq 8$ mm, $\leq 7$ mm and $\leq 5$ mm zoom scan resolution may be applied, respectively, for 2 GHz to 3 GHz, 3 GHz to 4 GHz and 4 GHz to 6 GHz.			

Step 4: Power drift measurement

The Power drift Measurement measures the field at the same location as the most recent power reference measurement within the same procedure, and with the same settings.

Step 5: Z-Scan (FCC only)

The Z Scan measures points along a vertical straight line. The line runs along the Z-axis of a one-dimensional grid. In order to get a reasonable extrapolation the extrapolated distance should not larger than the step size in Z-direction.

## 8. DESCRIPTION OF TEST POSITION

SAR measurements were performed in the “cheek” and “tilted” positions on left and right sides of the phantom according to IEEE 1528. Both were measured in the head section of the SAM Twin Phantom.

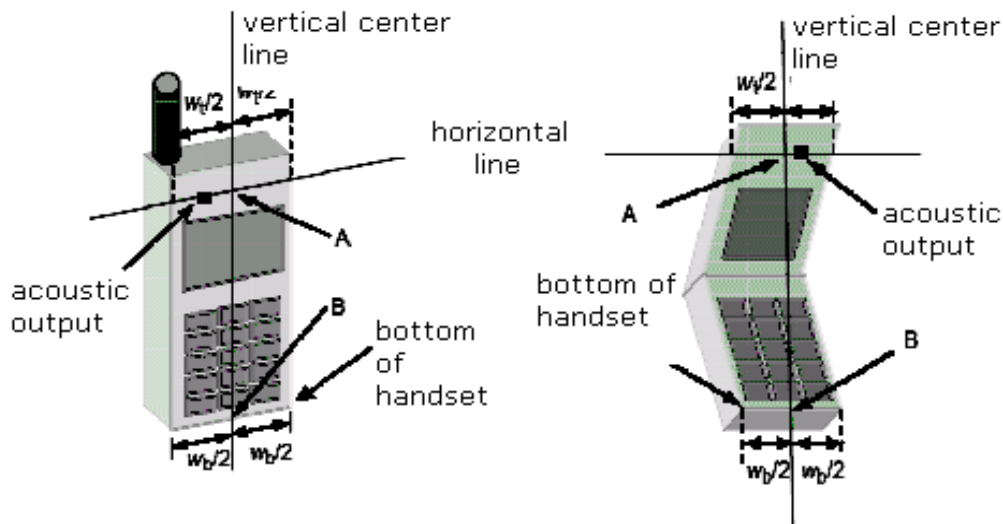

Figure 3 Handset vertical and horizontal reference line

### 8.1. Cheek Position

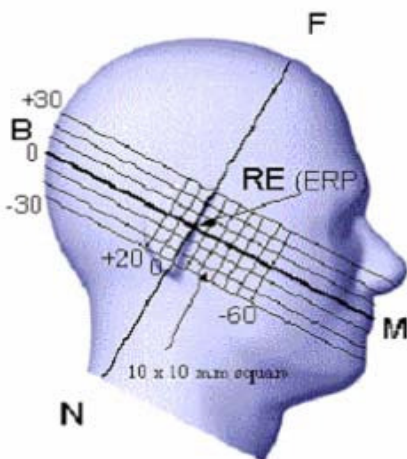

Figure 4 Side view of SAM phantom

The device was positioned with the vertical center line of the body of the device and the horizontal line crossing the center (see Figure 3) of the ear piece in a plane parallel to the sagittal plane of the phantom(see Figure 4). While maintaining the device in this plane, it was aligned the vertical center line with the reference plane containing the three ear and mouth reference points(M, RE and LE) and aligned the center of the ear piece with the line RE-LE. Then device was translated towards the phantom with the ear piece aligned with the line LE-RE until it touched the ear. While maintaining the device in the reference plane and maintaining the device contact with the ear, the bottom of the device was moved until any point on the front side is in contact with the cheek of the phantom.(see Figure 5)



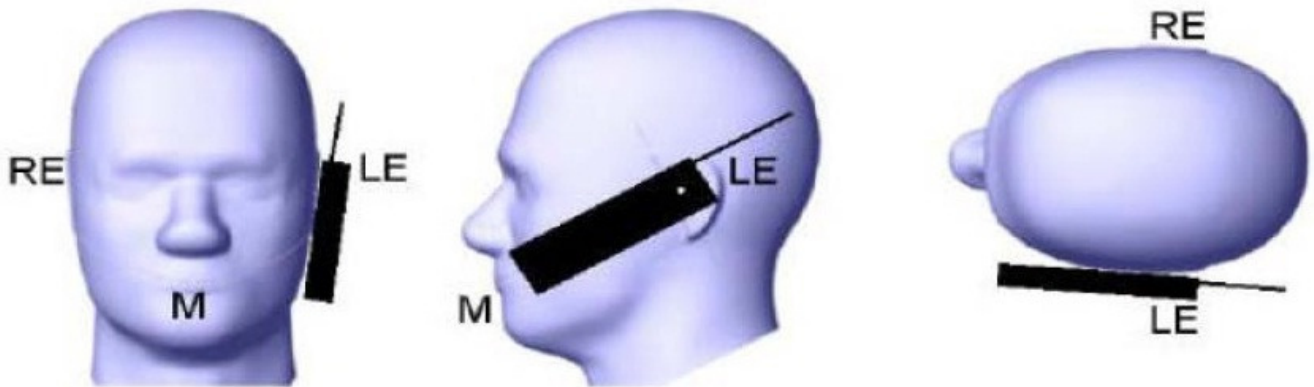

Figure 5 Cheek/Touch Position

## 8.2. Tilt Position

The device was positioned in the “Cheek” position. While maintaining the device in the reference plane described above cheek position and pivoting against the ear, device was moved outward away from the mouth by an angle of 15 degrees. (see Figure 6)

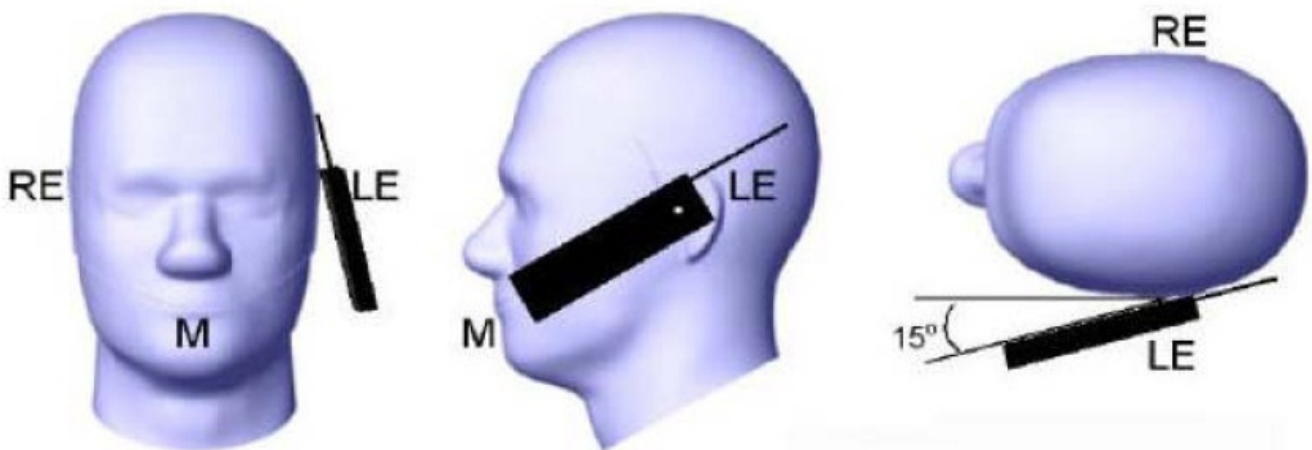

Figure 6 Ear/Tilt Position

Body-worn operating configurations are tested without the belt-clips and holsters attached to the device and positioned against a flat phantom in a normal use configuration.

Accessories for Body-worn operation configurations are divided into two categories: those that do not contain metallic components and those that do contain metallic components. When multiple accessories that do not contain metallic components are supplied with the device, the device is tested with only the accessory that dictates the closest spacing to the body. Then multiple accessories that contain metallic components are tested with the device with each accessory. If multiple accessories share an identical metallic component (i.e. the same metallic belt-clip used with different holsters with no other metallic components) only the accessory that dictates the closest spacing to the body is tested.



---

### 8.3. Body Holster/ Belt Clip Configurations

Body-worn accessories may not always be supplied or available as options for some devices intended to be authorized for body-worn use. In this case, a test configuration with a separation distance between the device and the flat phantom is used. Test position spacing was documented.

Transmitters that are designed to operate in front of a person's face, as the push-to-talk configurations, are test for SAR compliance with the front of the device positioned to face the flat phantom in brain fluid. For devices that are carried next to the body such as a shoulder, waist or chest-worn transmitters, SAR compliance is tested with the accessories, including headsets and microphones, attached to the device and positioned against a flat phantom in a normal use configuration.

In all cases SAR measurements are performed to investigate the worst-case positioning. Worst-case positioning is then documented and used to perform Body SAR testing.

## 9. MEASUREMENT UNCERTAINTY

Applicable for frequencies up to 6GHz

Uncertainty Component	Tol. (%)	Prob Dist	Div	$c_i$ 1g	$c_i$ 10g	$u_i$ (%) 1g	$u_i$ (%) 10g	$\nu_i$	
<b>Measurement System</b>									
Probe Calibration	± 6.55	N	1	1	1	± 6.55	± 6.55	∞	
Axial Isotropy	± 4.70	R	$\sqrt{3}$	0.7	0.7	± 1.90	± 1.90	∞	
Hemispherical Isotropy	± 9.60	R	$\sqrt{3}$	0.7	0.7	± 3.38	± 3.38	∞	
Linearity	± 4.70	R	$\sqrt{3}$	1	1	± 2.71	± 2.71	∞	
System Detection Limits	± 1.00	R	$\sqrt{3}$	1	1	± 0.58	± 0.58	∞	
Boundary Effect	± 1.00	R	$\sqrt{3}$	1	1	± 0.58	± 0.58	∞	
Response Time	± 0.80	R	$\sqrt{3}$	1	1	± 0.46	± 0.46	∞	
RF Ambient conditions	± 3.00	R	$\sqrt{3}$	1	1	± 1.73	± 1.73	∞	
Readout Electronics	± 1.00	N	1	1	1	± 1.00	± 1.00	∞	
Integration time	± 2.60	R	$\sqrt{3}$	1	1	± 1.50	± 1.50	∞	
Probe Positioner	± 0.40	R	$\sqrt{3}$	1	1	± 0.23	± 0.23	∞	
Probe Positioning	± 2.90	R	$\sqrt{3}$	1	1	± 1.67	± 1.67	∞	
Max. SAR evaluation	± 1.00	R	$\sqrt{3}$	1	1	± 0.58	± 0.58	∞	
<b>Test Sample Related</b>									
Device Positioning	± 2.90	N	1	1	1	± 2.90	± 2.90	145	
Device Holder	± 3.60	N	1	1	1	± 3.60	± 3.60	5	
Power Drift	± 5.00	R	$\sqrt{3}$	1	1	± 2.89	± 2.89	∞	
<b>Phantom and Setup</b>									
Phantom Uncertainty	± 4.00	R	$\sqrt{3}$	1	1	± 2.31	± 2.31	∞	
Liquid Conductivity (target)	± 5.00	R	$\sqrt{3}$	0.64	0.43	± 1.85	± 1.24	∞	
Liquid Conductivity (meas.)	± 2.07	N	1	0.78	0.71	± 1.61	± 1.47	9	
Liquid Permittivity (target)	± 5.00	R	$\sqrt{3}$	0.60	0.49	1.73	1.43	∞	
Liquid Permittivity (meas.)	± 3.07	N	1	0.26	0.26	± 0.80	± 0.80	9	
Combined Std. Uncertainty (k=1)						RSS	10.43	10.33	
<b>Expanded STD Uncertainty (95% CONFIDENCE LEVEL)</b>						<b>k=2</b>	20.87	20.66	

Table 4 Uncertainty Budget

## 10. FCC RF Exposure Limits

HUMAN EXPOSURE	UNCONTROLLED ENVIRONMENT	CONTROLLED ENVIRONMENT
	General Population (W/Kg) or (mW/g)	Occupational (W/Kg) or (mW/g)
SPATIAL PEAK SAR (Brain)	1.60	8.00
SPATIAL AVERAGE SAR (Whole Body)	0.08	0.40
SPATIAL PEAK SAR (Hand / Feet / Ankle / Wrist)	4.00	20.00

Table 6 Safety Limits for Partial Body Exposure

NOTE :

\* The Spatial Peak value of the SAR averaged over any 1 gram of tissue (defined as a tissue volume in the shape of a cube) and over the appropriate averaging time.

Uncontrolled Environments are defined as locations where there is the exposure of individuals who have no knowledge or control of their exposure.

Controlled Environments are defined as locations where there is exposure that may be incurred by persons who are aware of the potential for exposure, (i.e.as a result of employment or occupation).

## 11. RF CONDUCTED POWERS

### 11.1. Nominal and Maximum Output Power Specifications

This device operates using the following maximum and nominal output power specifications. SAR values were scaled to the maximum allowed power to determine compliance per KDB Publication 447498 D01v05.

Band & Mode		Voice [dBm]	Burst Average GMSK [dBm]				Burst Average 8PSK [dBm]			
		1TX Slot	1TX Slot	2TX Slot	3TX Slot	4TX Slot	1TX Slot	1TX Slot	1TX Slot	1TX Slot
GSM/GPRS/EDGE 850	Maximum	34.0	34.0	31.0	29.2	28.0	28.0	25.0	23.2	22.0
	Nominal	33.0	33.0	30.0	28.2	27.0	27.0	24.0	22.2	21.0
GSM/GPRS/EDGD1900	Maximum	31.0	31.0	28.0	26.2	25.0	27.0	24.0	22.2	21.0
	Nominal	30.0	30.0	27.0	25.2	24.0	26.0	23.0	21.2	20.0

Mode		Modulated Average Power (dBm)
UMTS Band V(850)	Maximum	25
	Nominal	24
UMTS Band II(1900)	Maximum	25
	Nominal	24
IEEE 802.11b (2.4G)	Maximum	16
	Nominal	14.5
IEEE 802.11g (2.4G)	Maximum	16
	Nominal	14.5
IEEE 802.11n (2.4G)	Maximum	16
	Nominal	14.5

### 11.2. SAR scaling factors sample calculation

Scaled SAR results are derived after scaling factors are applied to the measured values as below. Scaling for maximum tune-up tolerance must be considered separately.

SAR Section	Test Position	Mode	Scan	Dist. (mm)	Freq. (MHz)	CH #	Power (dBm)		SAR 1g (W/kg)	Scaling Factor	Scaled SAR 1g (W/kg)	Plot. No.
							Max. allowed	Measured				
Head	Right Touch	Voice	2D	N/A	837.6	4188	25.00	24.11	0.484	1.227	0.593	5

\*Scaled SAR = Measured SAR x Scaling Factor

$$0.593 = 0.484 \times 1.227$$

### 11.3. GSM/GPRS/EDGE Conducted output Power Measurements

Conducted output power measurements were performed with a base station simulator under digital average power. SAR measurements for GSM/GPRS/EDGE modes were performed with a base station simulator R&S CMU200. Communication between the device and the emulator was established by air link. Set base station emulator to allow DUT to radiate maximum output power during all tests. Followings are the worst configuration setup for SAR tests.

- \* GSM voice: Head SAR
- \* GPRS Multi-slots: Body SAR with GPRS Multi-slot Class12 with CS 1 (GMSK)

Note;

CS1/MCS7 coding scheme was used in GPRS/EDGE output power measurements and SAR Testing, as a condition where GMSK/8PSK modulation was ensured. Investigation has shown that CS1 - CS4/ MCS5 -MCS9 settings do not have any impact on the output levels in the GPRS/EDGE modes.



Figure 7 Power Measurement Setup

**11.4. GSM/GPRS/EDGE Conducted output Powers**

Band	Mode	Multi Slot	Maximum Burst-Averaged Output Power (dBm)			Calculated Maximum Frame-Averaged Output Power(dBm)		
			128CH	190CH	251CH	128CH	190CH	251CH
GSM850	GSM	1 Tx slot	33.16	33.23	33.21	24.13	24.20	24.18
	GPRS	1 Tx slot	33.13	33.21	33.18	24.10	24.18	24.15
		2 Tx slots	30.60	30.73	30.61	<b>24.58</b>	<b>24.71</b>	<b>24.59</b>
		3 Tx slots	28.71	28.74	28.87	24.44	24.47	24.60
		4 Tx slots	27.22	27.44	27.32	24.21	24.43	24.31
	EDGE	1 Tx slot	27.13	27.01	26.89	18.10	17.98	17.86
		2 Tx slots	23.70	23.62	23.45	17.68	17.60	17.43
		3 Tx slots	21.96	21.83	21.70	17.69	17.56	17.43
		4 Tx slots	21.25	21.13	20.99	18.24	18.12	17.98

Band	Mode	Multi Slot	Maximum Burst-Averaged Output Power (dBm)			Calculated Maximum Frame-Averaged Output Power(dBm)		
			512CH	661CH	810CH	512CH	661CH	810CH
GSM1900	GSM	1 Tx slot	29.76	29.56	30.01	20.73	20.53	20.98
	GPRS	1 Tx slot	29.68	29.65	29.71	20.65	20.62	20.68
		2 Tx slots	26.79	26.65	26.78	<b>20.77</b>	<b>20.63</b>	<b>20.76</b>
		3 Tx slots	24.82	24.81	24.86	20.55	20.54	20.59
		4 Tx slots	23.40	23.59	23.44	20.39	20.58	20.43
	EDGE	1 Tx slot	26.51	25.75	25.71	17.48	16.72	16.68
		2 Tx slots	23.23	22.81	22.57	17.21	16.79	16.55
		3 Tx slots	21.81	21.23	21.01	17.54	16.96	16.74
		4 Tx slots	20.42	19.85	19.64	17.41	16.84	16.63

Note:

- Both burst-averaged and calculated frame-averaged powers are included. Frame-averaged power was calculated from the measured burst-averaged power by converting the slot powers into linear units and calculating the energy over 8 timeslots.
- The 2 Tx slots GPRS modes were selected for SAR testing according to the highest frame-averaged output power table according to KDB 941225 D03v01.



## 11.5. UMTS Conducted output Power Measurements

### Procedures Used to Establish RF Signal for SAR

The following procedures are according to FCC KDB Publication 941225 D01 "SAR Measurement Procedures for 3G Devices" V2, October 2007.

The device was placed into a simulated call using a base station simulator R&S CMU200. Establishing connections in this manner ensure a consistent means for SAR and are recommended for evaluating SAR. EUTs were evaluated prior to testing, with a fully charged battery and were configured to operate at maximum output power.

### Output Power Verification

Maximum output power is verified on the High, Middle and Low channels according to the general descriptions in section 5.2 of 3 GPP TS 34.121, using the appropriate RMC or AMR with TPC(transmit power control) set to all "1s".

### Head SAR Measurements

SAR for head exposure configurations is measured using the 12.2 kbps RMC with TPC bits configured to all "1s". SAR in AMR configurations is not required when the maximum average output of each RF channel for 12.2 kbps AMR is less than ¼ dB higher than that measured in 12.2 kbps RMC. Otherwise, SAR is measured on the maximum output channel in 12.2 AMR with a 3.4 kbps SRB (signaling radio bearer) using the exposure configuration that results in the highest SAR for that RF channel in 12.2 RMC.

### Body SAR Measurements

SAR for body exposure configurations is measured using the 12.2 kbps RMC with the TPC bits all "1s".

### Handsets with Release 5 HSDPA

Body SAR is not required for handsets with HSDPA capabilities when the maximum average output of each RF channel with HSDPA active is less than ¼ dB higher than that measured without HSDPA using 12.2 kbps RMC and the maximum SAR for 12.2 kbps RMC is ≤ 75 % of the SAR limit. Otherwise, SAR is Measured for HSDPA, using an FRC with H-Set 1 in Sub-test 1 and a 12.2 kbps RMC configured in Test Loop Mode 1, using the highest body SAR configuration in 12.2 kbps RMC without HSDPA, on the maximum output channel with the body exposure configuration that results in the highest SAR in 12.2kbps RMC for that RF channel.

**Sub-Test 1 Setup for Release 5 HSDPA**

Sub-test	$\beta_c$	$\beta_d$	$\beta_d$ (SF)	$\beta_c/\beta_d$	$\beta_{hs}^{(1)}$	CM (dB) <sup>(2)</sup>
1	2/15	15/15	64	2/15	4/15	0.0
2	12/15 <sup>(3)</sup>	15/15 <sup>(3)</sup>	64	12/15 <sup>(3)</sup>	24/15	1.0
3	15/15	8/15	64	15/8	30/15	1.5
4	15/15	4/15	64	15/4	30/15	1.5

Note 1:  $\Delta_{ACK}$ ,  $\Delta_{NACK}$  and  $\Delta_{CQI} = 8 \Leftrightarrow A_{hs} = \beta_{hs}/\beta_c = 30/15 \Leftrightarrow \beta_{hs} = 30/15 * \beta_c$   
 Note 2: CM = 1 for  $\beta_c/\beta_d = 12/15$ ,  $\beta_{hs}/\beta_c = 24/15$ .  
 Note 3: For subtest 2 the  $\beta_c/\beta_d$  ratio of 12/15 for the TFC during the measurement period (TF1, TF0) is achieved by setting the signaled gain factors for the reference TFC (TF1, TF1) to  $\beta_c = 11/15$  and  $\beta_d = 15/15$ .

**Handsets with Release 6 HSPA (HSDPA/HSUPA)**

Body SAR is not required for handsets with HSPA capabilities when the maximum average output of each RF channel with HSUPA/HSDPA active is less than ¼ dB higher than that measured without HSUPA/HSDPA using 12.2 kbps RMC and the maximum SAR for 12.2 kbps RMC is ≤ 75 % of the SAR limit. Body SAR for HSPA is measured with E-DCH Sub-test 5, using H-Set 1 and QPSK for FRC and a 12.2 kbps RMC configured in Test Loop Mode 1 with power control algorithm 2, according to the highest body SAR configuration in 12.1 kbps RMC without HSPA. When VOIP is applicable for head exposure, SAR is not required when the maximum output of each RF channel with HSPA is less than ¼ dB higher than that measured using 12.2 kbps RMC; otherwise, the same HSPA configuration used for body measurement should be used to test for head exposure.

Sub-test	$\beta_c$	$\beta_d$	$\beta_d$ (SF)	$\beta_c/\beta_d$	$\beta_{hs}^{(1)}$	$\beta_{ec}$	$\beta_{ed}$	$\beta_{ed}$ (SF)	$\beta_{ed}$ (codes)	CM <sup>(2)</sup> (dB)	MPR (dB)	AG <sup>(4)</sup> Index	E-TFCI
1	11/15 <sup>(3)</sup>	15/15 <sup>(3)</sup>	64	11/15 <sup>(3)</sup>	22/15	209/225	1039/225	4	1	1.0	0.0	20	75
2	6/15	15/15	64	6/15	12/15	12/15	94/75	4	1	3.0	2.0	12	67
3	15/15	9/15	64	15/9	30/15	30/15	$\beta_{ed}: 47/15$ $\beta_{ed}: 47/15$	4	2	2.0	1.0	15	92
4	2/15	15/15	64	2/15	4/15	2/15	56/75	4	1	3.0	2.0	17	71
5	15/15 <sup>(4)</sup>	15/15 <sup>(4)</sup>	64	15/15 <sup>(4)</sup>	30/15	24/15	134/15	4	1	1.0	0.0	21	81

Note 1:  $\Delta_{ACK}, \Delta_{NACK}$  and  $\Delta_{CQI} = 8 \Leftrightarrow A_{is} = \beta_{hs}/\beta_c = 30/15 \Leftrightarrow \beta_{hs} = 30/15 * \beta_c$ .  
 Note 2: CM = 1 for  $\beta_c/\beta_d = 12/15, \beta_{hs}/\beta_c = 24/15$ . For all other combinations of DPDCH, DPCCH, HS-DPCCH, E-DPDCH and E-DPCCH the MPR is based on the relative CM difference.  
 Note 3: For subtest 1 the  $\beta_c/\beta_d$  ratio of 11/15 for the TFC during the measurement period (TF1, TF0) is achieved by setting the signaled gain factors for the reference TFC (TF1, TF1) to  $\beta_c = 10/15$  and  $\beta_d = 15/15$ .  
 Note 4: For subtest 5 the  $\beta_c/\beta_d$  ratio of 15/15 for the TFC during the measurement period (TF1, TF0) is achieved by setting the signaled gain factors for the reference TFC (TF1, TF1) to  $\beta_c = 14/15$  and  $\beta_d = 15/15$ .  
 Note 5: Testing UE using E-DPDCH Physical Layer category 1 Sub-test 3 is not required according to TS 25.306 Table 5.1g.  
 Note 6:  $\beta_{ed}$  can not be set directly; it is set by Absolute Grant Value.



**11.6. UMTS Conducted output Powers**

Band	Mode	3GPP 34.121 Subtest	Conducted Powers (dBm)		
			4132CH	4175CH	4233CH
WCDMA850	WCDMA	12.2 kbps RMC	<b>23.86</b>	<b>23.87</b>	<b>24.11</b>
		12.2 kbps AMR	23.84	23.85	24.06
	HSDPA	Subtest 1	23.50	23.50	23.41
		Subtest 2	23.70	23.69	23.42
		Subtest 3	23.20	23.20	23.16
		Subtest 4	23.18	23.21	23.01
	HSUPA	Subtest 1	22.48	22.92	22.61
		Subtest 2	21.67	21.42	21.43
		Subtest 3	21.84	21.89	22.01
		Subtest 4	21.70	21.68	21.80
		Subtest 5	22.50	23.01	23.37

Band	Mode	3GPP 34.121 Subtest	Conducted Powers (dBm)		
			9262CH	9400CH	9538CH
WCDMA1900	WCDMA	12.2 kbps RMC	<b>23.71</b>	<b>23.71</b>	<b>23.70</b>
		12.2 kbps AMR	23.66	23.68	23.68
	HSDPA	Subtest 1	23.40	23.81	23.25
		Subtest 2	23.61	23.54	23.33
		Subtest 3	23.20	23.24	22.85
		Subtest 4	23.28	23.29	23.15
	HSUPA	Subtest 1	22.81	22.83	22.60
		Subtest 2	21.70	21.56	21.45
		Subtest 3	22.06	21.93	21.93
		Subtest 4	22.00	21.52	21.49
		Subtest 5	22.39	22.60	22.44

Note:

1. The UMTS output powers were measured according to the test requirements outlined in section 5.2 of 3GPP TS34.121-1.
2. UMTS SAR was tested under RMC 12.2 kbps with HSPA Inactive per KDB Publication 941225 D01v02.
3. HSPA SAR was not required since the average output power of the HSPA subsets was not more than 0.25 dB higher than the RMC level and SAR was less than 1.2 W/kg.

### 11.7. 802.11b/g/n (2.4GHz) Conducted Output Powers

#### Required Test channels

Mode	Band	Frequency (GHz)	Channel	“Default Test Channels”	
				802.11b	802.11g
802.11b	2.4 GHz	2.412	1 <sup>#</sup>	√	▽
		2.437	6	√	▽
		2.462	11 <sup>#</sup>	√	▽

Notes:

√ = “default test channels”

▽ = possible 802.11g channels with maximum average output 1/4 dB higher than the “default test channels”

<sup>#</sup> = when output power is reduced for channel 1 and/or 11 to meet restricted band requirements the highest output channels closest to each of these channels should be tested.

#### Conducted Output Powers

WLAN mode	Worst Power Data Rate [Mbps]	Conducted Powers (dBm)		
		2412MHz	2437MHz	2462MHz
802.11b	1	13.93	<b>14.12</b>	14.03
	2	14.01	13.95	13.93
	5.5	13.90	13.82	14.08
	11	13.95	13.96	14.08
802.11g	6	14.08	14.08	14.09
	9	13.94	14.20	13.95
	12	13.96	14.71	14.16
	18	14.12	<b>14.97</b>	14.25
	24	13.95	13.99	14.32
	36	14.08	14.28	14.06
	48	13.88	13.87	13.87
	54	13.51	13.80	13.71
802.11n	MCS0	13.61	13.82	13.80
	MCS1	13.96	13.98	13.98
	MCS2	13.85	13.97	13.85
	MCS3	13.61	14.25	13.90
	MCS4	13.94	13.87	13.99
	MCS5	13.47	13.33	13.54
	MCS6	13.53	13.35	13.36
	MCS7	12.50	12.75	12.62

Note: Per KDB 248227 D01, SAR is not required for 802.11n mode when the maximum average output power is less than 1/4 dB higher than that measured on the corresponding 802.11b mode.

### 11.8. Bluetooth Conducted Output Powers

Modulation	Max Allowed Output Power (mW)
Bluetooth (GFSK, 8-DPSK)	2.52 (4dBm)

Per FCC KDB 447498 D01v05, the SAR exclusion threshold for distance <50mm is defined by the following equation:

$$\frac{\text{Max Power of Channel (mW)}}{\text{Test Separation Dist (mm)}} * \sqrt{\text{Frequency(GHz)}} \leq 3.0$$

Based on the maximum conducted power of Bluetooth (rounded to the nearest mW) and the antenna to user separation distance, **Bluetooth body-worn accessory SAR was not required.**  $[(2.52/15)*\sqrt{2.441}] = 0.26 < 3.0$

## 12. SAR TEST CONDITIONS & ANTENNA INFORMATION

### 12.1. Standalone SAR Measurements

Test Modes	Head SAR	Body SAR	Note
WWAN	Yes	Yes	
2.4 GHz WLAN	Yes	Yes	
Bluetooth	No	No	SAR is not required according to the KDB 447498 D01 - 1g SAR test Exclusion thresholds conditions.

### 12.2. Simultaneous SAR Measurements

RF Exposure Condition	Capable Transmit Configurations
Head	WWAN+BT only
Body	WWAN+BT only
Hotspot & WiFi Direct	Not supported

### 12.3. Antenna Information

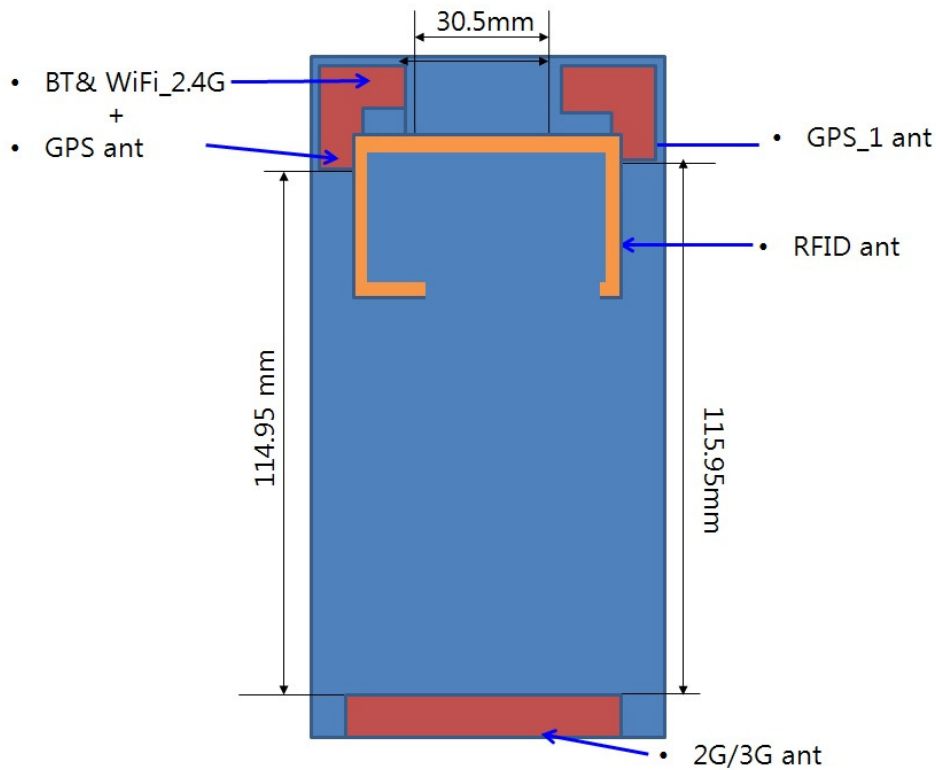

## 13. SAR MEASUREMENT RESULTS

### 13.1. GSM850 SAR Measurement Results

SAR Section	Test Position	Mode	Scanner	Dist. (mm)	Freq. (MHz)	CH #	Power (dBm]		SAR 1g (W/kg)	Scaling Factor	Scaled SAR 1g (W/kg)	Plot. No.
							Max. allowed	Mea-sured				
Head	Left Touch	Voice	2D N560x	N/A	836.6	190	34.00	33.23	0.258	1.193	0.308	-
	Left Tilt	Voice	2D N560x	N/A	836.6	190	34.00	33.23	0.143	1.193	0.171	-
	Right Touch	Voice	2D N560x	N/A	836.6	190	34.00	33.23	0.290	1.193	0.346	-
	Right Tilt	Voice	2D N560x	N/A	836.6	190	34.00	33.23	0.140	1.193	0.167	-
	Right Touch	Voice	2D N560x	N/A	824.2	128	34.00	33.16	0.289	1.213	0.351	-
	Right Touch	Voice	2D N560x	N/A	848.8	251	34.00	33.21	0.459	1.199	<b>0.550</b>	<b>1</b>
Body	Front	Voice	2D N560x	15	836.6	190	34.00	33.23	0.234	1.193	0.279	-
	Rear	Voice	2D N560x	15	836.6	190	34.00	33.23	0.289	1.193	0.345	-
	Rear	GPRS 2TX	2D N560x	15	836.6	190	31.00	30.73	0.229	1.064	0.244	-
	Rear	Voice	2D N560x	15	824.2	128	34.00	33.16	0.266	1.213	0.323	-
	Rear	Voice	2D N560x	15	848.8	251	34.00	33.21	0.297	1.199	<b>0.356</b>	<b>2</b>
ANSI/IEEE C95.1 – 1992-Safety Limit Spatial Peak Uncontrolled Exposure/ General Population							1.6 W/kg (mW/g) Averaged over 1 gram					

### 13.2. GSM1900 SAR Measurement Results

SAR Section	Test Position	Mode	Scanner	Dist. (mm)	Freq. (MHz)	CH #	Power (dBm]		SAR 1g (W/kg)	Scaling Factor	Scaled SAR 1g (W/kg)	Plot. No.
							Max. allowed	Mea-sured				
Head	Right Touch	Voice	2D N560x	N/A	1880	661	31.00	29.56	0.067	1.393	0.093	-
	Right Tilt	Voice	2D N560x	N/A	1880	661	31.00	29.56	0.033	1.393	0.046	-
	Left Touch	Voice	2D N560x	N/A	1880	661	31.00	29.56	0.074	1.393	<b>0.103</b>	<b>3</b>
	Left Tilt	Voice	2D N560x	N/A	1880	661	31.00	29.56	0.049	1.393	0.068	-
	Left Touch	Voice	2D N560x	N/A	1850.2	512	31.00	29.76	0.041	1.330	0.054	-
	Left Touch	Voice	2D N560x	N/A	1909.8	810	31.00	30.01	0.064	1.256	0.080	-
Body	Front	Voice	2D N560x	15	1880	661	31.00	29.56	0.085	1.393	0.118	-
	Rear	Voice	2D N560x	15	1880	661	31.00	29.56	0.197	1.393	<b>0.274</b>	<b>4</b>
	Rear	GPRS 2TX	2D N560x	15	1880	661	28.00	26.65	0.170	1.365	0.232	-
	Rear	Voice	2D N560x	15	1850.2	512	31.00	29.76	0.054	1.330	0.072	-
	Rear	Voice	2D N560x	15	1909.8	810	31.00	30.01	0.142	1.256	0.178	-
ANSI/IEEE C95.1 – 1992-Safety Limit Spatial Peak Uncontrolled Exposure/ General Population							1.6 W/kg (mW/g) Averaged over 1 gram					

### 13.3. UMTS850 SAR Measurement Results

SAR Section	Test Position	Mode	Scanner	Dist. (mm)	Freq. (MHz)	CH #	Power (dBm)		SAR 1g (W/kg)	Scaling Factor	Scaled SAR 1g (W/kg)	Plot. No.
							Max. allowed	Mea-sured				
Head	Left Touch	RMC	2D N560x	N/A	835	4175	25.00	23.87	0.256	1.296	0.332	-
	Left Tilt	RMC	2D N560x	N/A	835	4175	25.00	23.87	0.144	1.296	0.187	-
	Right Touch	RMC	2D N560x	N/A	835	4175	25.00	23.87	0.267	1.296	0.346	-
	Right Tilt	RMC	2D N560x	N/A	835	4175	25.00	23.87	0.141	1.296	0.183	-
	Right Touch	RMC	2D N560x	N/A	826.4	4132	25.00	23.86	0.421	1.300	0.547	
	Right Touch	RMC	2D N560x	N/A	846.6	4233	25.00	24.11	0.484	1.227	<b>0.593</b>	<b>5</b>
Body	Front	RMC	2D N560x	15	835	4175	25.00	23.87	0.248	1.296	0.321	-
	Rear	RMC	2D N560x	15	835	4175	25.00	23.87	0.294	1.296	0.381	-
	Rear	RMC	2D N560x	15	826.4	4132	25.00	23.86	0.329	1.300	0.428	
	Rear	RMC	2D N560x	15	846.6	4233	25.00	24.11	0.331	1.227	<b>0.406</b>	<b>6</b>
ANSI/IEEE C95.1 – 1992-Safety Limit Spatial Peak Uncontrolled Exposure/ General Population							1.6 W/kg (mW/g) Averaged over 1 gram					

### 13.4. UMTS1900 SAR Measurement Results

SAR Section	Test Position	Mode	Scanner	Dist. (mm)	Freq. (MHz)	CH #	Power (dBm)		SAR 1g (W/kg)	Scaling Factor	Scaled SAR 1g (W/kg)	Plot. No.
							Max. allowed	Mea-sured				
Head	Right Touch	RMC	2D N560x	N/A	1880	9400	25.00	23.71	0.120	1.345	0.161	-
	Right Tilt	RMC	2D N560x	N/A	1880	9400	25.00	23.71	0.066	1.345	0.088	-
	Left Touch	RMC	2D N560x	N/A	1880	9400	25.00	23.71	0.138	1.345	<b>0.185</b>	<b>7</b>
	Left Tilt	RMC	2D N560x	N/A	1880	9400	25.00	23.71	0.093	1.345	0.125	-
	Left Touch	RMC	2D N560x	N/A	1852.4	9262	25.00	23.71	0.127	1.345	0.171	-
	Left Touch	RMC	2D N560x	N/A	1907.6	9538	25.00	23.70	0.115	1.349	0.155	-
Body	Front	RMC	2D N560x	15	1880	9400	25.00	23.71	0.143	1.345	0.192	-
	Rear	RMC	2D N560x	15	1880	9400	25.00	23.71	0.384	1.345	<b>0.516</b>	<b>8</b>
	Rear	RMC	2D N560x	15	1852.4	9262	25.00	23.71	0.293	1.345	0.394	-
	Rear	RMC	2D N560x	15	1907.6	9538	25.00	23.70	0.269	1.349	0.363	-
ANSI/IEEE C95.1 – 1992-Safety Limit Spatial Peak Uncontrolled Exposure/ General Population							1.6 W/kg (mW/g) Averaged over 1 gram					

### 13.5. WLAN (2.4GHz) SAR Measurements Results

SAR Section	Test Position	Mode	Scanner	Dist. (mm)	Freq. (MHz)	CH #	Power (dBm)		SAR 1g (W/kg)	Scaling Factor	Scaled SAR 1g (W/kg)	Plot No.
							Max. allowed	Mea-sured				
Head	Right Touch	802.11b	2D N560x	N/A	2437	6	16.00	14.12	0.049	1.531	0.075	-
	Right Tilt	802.11b	2D N560x	N/A	2437	6	16.00	14.12	0.033	1.531	0.051	-
	Left Touch	802.11b	2D N560x	N/A	2437	6	16.00	14.12	0.109	1.531	0.167	-
	Left Tilt	802.11b	2D N560x	N/A	2437	6	16.00	14.12	0.066	1.531	0.101	-
	Left Touch	802.11b	2D N560x	N/A	2412	1	16.00	13.93	0.038	1.611	0.061	-
	Left Touch	802.11b	2D N560x	N/A	2462	11	16.00	14.03	0.049	1.574	0.077	-
	Left Touch	802.11g	2D N560x	N/A	2437	6	16.00	14.97	0.138	1.267	<b>0.175</b>	<b>9</b>
	Left Touch	802.11g	2D N560x	N/A	2412	1	16.00	14.12	0.095	1.531	0.145	-
	Left Touch	802.11g	2D N560x	N/A	2462	11	16.00	14.25	0.081	1.496	0.121	-
Body	Rear	802.11b	2D N560x	15	2437	6	16.00	14.12	0.029	1.531	0.044	-
	Front	802.11b	2D N560x	15	2437	6	16.00	14.12	0.067	1.531	0.103	-
	Front	802.11b	2D N560x	15	2412	1	16.00	13.93	0.055	1.611	0.089	-
	Front	802.11b	2D N560x	15	2462	11	16.00	14.03	0.071	1.574	0.112	-
	Front	802.11g	2D N560x	15	2437	6	16.00	14.97	0.101	1.267	<b>0.128</b>	<b>10</b>
	Front	802.11g	2D N560x	15	2412	1	16.00	14.12	0.090	1.531	0.138	-
	Front	802.11g	2D N560x	15	2462	11	16.00	14.25	0.095	1.496	0.142	-
<b>ANSI/IEEE C95.1 – 1992-Safety Limit Spatial Peak</b> Uncontrolled Exposure/ General Population							<b>1.6 W/kg (mW/g)</b> Averaged over 1 gram					

---

## 13.6. SAR Test Notes

### General Notes:

1. The test data reported are the worst-case SAR values according to test procedures specified in IEEE 1528-2003, FCC KDB Procedure.
2. Batteries are fully charged at the beginning of the SAR measurements.
3. Liquid tissue depth was at least 15.0 cm for all frequencies.
4. The manufacturer has confirmed that the device(s) tested have the same physical, mechanical and thermal characteristics and are within operational tolerances expected for production units.
- 5 SAR results were scaled to the maximum allowed power to demonstrate compliance per FCC KDB 447498 D01v05.
- 6 Per FCC KDB 648474 D04v01, SAR was evaluated without a headset connected to the device. Since the standalone reported SAR was less than 1.2 W/kg, no additional SAR evaluation using a headset cable were required.
- 7 Per FCC KDB 865664 D01v01, variability SAR tests were not performed since the measured SAR results for all frequency bands were less than 0.8 W/kg. Please see Section 13 for variability analysis information.

### GSM/GPRS Test Notes:

1. Body-Worn accessory testing is typically associated with voice operations. Therefore, GSM voice was evaluated for body-worn SAR.
2. Justification for reduced test configurations per KDB 941225 D03v01: The source-based time-averaged output power was evaluated for all multi-slot operations. The multi-slot configuration with the highest frame averaged output power was evaluated for SAR.
3. Per FCC KDB 447498 D01v05, if the reported (scaled) SAR measured at the middle channel or highest output power channel for each test configuration is  $\leq 0.8$  W/kg then testing at the other channels is not required for such test configuration(s). When the maximum output power variation across the required test channels is  $\leq 1/2$  dB, instead of the middle channel, the highest output power channel must be used.

### UMTS Test Notes:

1. UMTS mode in Body SAR was tested under RMC 12.2 kbps with HSPA inactive per KDB 941225 D01v02. HSPA SAR was not required since the average output power of the HSPA subtests was not more than 0.25 dB higher than the RMC level and SAR was less than 1.2 W/kg.
2. Per FCC KDB 447498 D01v05, if the reported (scaled) SAR measured at the middle channel or highest output power channel for each test configuration is  $\leq 0.8$  W/kg then testing at the other channels is not required for such test configuration(s). Since the maximum output power variation across the required test channels is  $\leq 1/2$  dB, middle channel was the default channel used.



**WLAN Test Notes:**

1. Justification for reduced test configurations for WIFI channels per KDB 248227 D01v01r02 and Oct. 2012 FCC/TCB Meeting Notes for 2.4 GHz WIFI: Highest average RF output power channel for the worst data rate was selected for SAR evaluation in 802.11b/g. 802.11n mode was not investigated since the average output powers over all channels and data rates were not more than 0.25 dB higher than the tested channel in the lowest data rate of IEEE 802.11b mode.
2. Since the maximum extrapolated peak SAR of the zoom scan for the maximum output channel was  $\leq 1.6$  W/kg and the reported 1g averaged SAR was  $\leq 0.8$  W/kg, SAR testing on other default channels was not required.

## 14. FCC MULTI-TX CONSIDERATION

### 14.1. Introduction

The following procedures adopted from FCC KDB Publication 447498 D01v05 are applicable to handsets with built-in unlicensed transmitters such as 802.11a/b/g/n/ac and Bluetooth devices which may simultaneously transmit with the licensed transmitter.

### 14.2. Simultaneous Transmission Procedures

This device contains transmitter that may operate simultaneously. Therefore simultaneous transmission analysis is required. Per FCC KDB 447498 D01v05 IV.C.1.iii, simultaneous transmission SAR test exclusion may be applied when the sum of the 1-g SAR for all the simultaneous transmitting antennas in a specific physical test configuration is  $\leq 1.6$  W/kg. When standalone SAR is not required to be measured, per FCC KDB 447498 D01v05 4.3.2 2), the following equation must be used to estimate the standalone 1g SAR for simultaneous transmission assessment involving that transmitter.

$$\text{Estimated SAR} = \frac{\sqrt{f(\text{GHz})}}{7.5} * \frac{(\text{Max Power of channel, mW})}{\text{Min. Separation Distance, mm}}$$

Mode	Frequency	Maximum Allowed Power		Separation Distance (body)	Estimated SAR(body)
	[MHz]	[dBm]	[mW]	[mm]	[W/kg]
Bluetooth	2441	4.00	2.52	15	0.035

Note: Per KDB Publication 447498 D01v05r01, the maximum power of the channel was rounded to the nearest mW before calculation.

### 14.3. Head & Body SAR Simultaneous Transmission Analysis

Worst Configuration	Mode	2G/3G SAR (W/kg)	Bluetooth SAR (W/kg)	$\Sigma$ SAR (W/kg)
Head Right Touch	GSM850	0.550	0.035	0.585
Head Left Touch	GSM1900	0.103	0.035	0.138
Head Right Touch	WCDMA850	0.593	0.035	0.628
Head Left Touch	WCDMA1900	0.185	0.035	0.220
Body Rear Side	GSM850	0.356	0.035	0.391
Body Rear Side	GSM1900	0.274	0.035	0.309
Body Rear Side	WCDMA850	0.406	0.035	0.441
Body Rear Side	WCDMA1900	0.516	0.035	0.551

Note: Bluetooth SAR was not required to be measured per FCC KDB 447498. Estimated SAR results were used in the above table to determine simultaneous transmission SAR test exclusion.

## 15. SAR MEASUREMENT VARIABILITY

### 15.1. Measurement Variability

Per FCC KDB Publication 865864 D01v01, SAR measurement variability was assessed when measured 1g SAR is  $> 0.80$  W/kg or when measured 10g SAR is  $> 2.00$  W/kg. Since all measured 1g SAR values were  $< 0.8$  W/kg SAR measurement variability was not assessed.

### 15.2. Measurement Uncertainty

The measured SAR was  $< 1.5$  W/kg for all frequency bands. Therefore, per KDB Publication 865664 D01v01, the extended measurement uncertainty analysis per IEEE 1528-2003 was not required.

## 16. CONCLUSION

The SAR evaluation indicates that NAUTIZ X4 complies with the RF radiation exposure limits of the FCC. These measurements were taken to simulate the RF effects of RF exposure under worst-case conditions. Precise laboratory measures were taken to assure repeatability of the tests. The results and statements relate only to the item(s) tested.

## 17. EQUIPMENT LIST AND CALIBRATION DETAILS

Equipment Type	Manufacturer	Model Number	Serial Number	Calibration Due	Used For this Test
Robot - Six Axes	Staubli	RX60	N/A	N/A	<input checked="" type="checkbox"/>
Robot Remote Control	SPEAG	CS7MB	F03/5U96A1 /C/01	N/A	<input checked="" type="checkbox"/>
SAM Twin Phantom	SPEAG	TP1276	QD000P40CA	N/A	<input checked="" type="checkbox"/>
Flat Phantom V4.4	SPEAG	QD000P44BA,BB	1001, higher	N/A	<input type="checkbox"/>
Data Acquisition Electronics	SPEAG	DAE4	1422	2015.01.14	<input checked="" type="checkbox"/>
Probe E-Field	SPEAG	ES3DV2	3020	2015.02.25	<input checked="" type="checkbox"/>
Probe E-Field	SPEAG	EX3DV4	3905	2015.02.26	<input type="checkbox"/>
Probe E-Field	SPEAG	EX3DV4	3972	2015.01.28	<input checked="" type="checkbox"/>
Antenna Dipole 835 MHz	SPEAG	D835V2	481	2015.04.25	<input checked="" type="checkbox"/>
Antenna Dipole 900 MHz	SPEAG	D900V2	194	2015.11.20	<input type="checkbox"/>
Antenna Dipole 1800 MHz	SPEAG	D1800V2	2d066	2016.01.23	<input type="checkbox"/>
Antenna Dipole 1900 MHz	SPEAG	D1900V2	5d038	2015.05.13	<input checked="" type="checkbox"/>
Antenna Dipole 1950 MHz	SPEAG	D1950V2	1027	2016.01.22	<input type="checkbox"/>
Antenna Dipole 2450 MHz	SPEAG	D2450V2	746	2016.01.21	<input checked="" type="checkbox"/>
Antenna Dipole 5000 MHz	SPEAG	5GHzV2	1107	2015.02.21	<input type="checkbox"/>
High power RF Amplifier	EMPOWER	2057- BBS3Q5KCK	1002D/C0321	2015.03.06	<input checked="" type="checkbox"/>
Digital Communication Tester	R&S	CMU200	111356	2015.01.15	<input checked="" type="checkbox"/>
Digital Communication Tester	Agilent	E5515C	G44400380	2014.10.28	<input type="checkbox"/>
Signal Generator	Hewlett Packard	8648C	3629U00868	2015.02.18	<input checked="" type="checkbox"/>
Signal Generator	R&S	SMBV100A	1407.6004k02- 259341-Ez	2014.10.10	<input checked="" type="checkbox"/>
RF Power Meter Dual	Hewlett Packard	EPM-442A	GG37170495	2015.03.04	<input checked="" type="checkbox"/>
RF Power Sensor 0.01 - 18 GHz	Hewlett Packard	8481A	US37299851	2015.03.14	<input checked="" type="checkbox"/>
RF Power Sensor 0.01 - 18 GHz	Hewlett Packard	8481A	3318A92872	2015.03.14	<input checked="" type="checkbox"/>
S-Parameter Network Analyzer	Agilent	8753D	3410A07251	2015.03.07	<input checked="" type="checkbox"/>
Dual Directional Coupler	Hewlett Packard	778D	1144AO4576	2015.03.04	<input checked="" type="checkbox"/>
Directional Coupler	Agilent	773D	MY28390213	2015.03.04	<input checked="" type="checkbox"/>

## APPENDIX A. SAR PLOTS

- Test Laboratory: KTL
- Model: NAUTIZ X4
- Position: GSM850 RIGHT CHEEK TOUCH\_251CH
- Test Date: 05/12/2014
- Measured Liquid Temperature: 22.3 °C, Ambient Temperature: 22.1 °C

Communication System: GSM 850; Frequency: 848.8 MHz; Duty Cycle: 1:8.3  
Medium: HSL835 Medium parameters used:  $f = 848.8$  MHz;  $\sigma = 0.93$  mho/m;  $\epsilon_r = 41.9$ ;  $\rho = 1000$  kg/m<sup>3</sup>  
Phantom section: Right Section  
Measurement Standard: DASY4 (High Precision Assessment)

DASY4 Configuration:

- Probe: ES3DV2 - SN3020; ConvF(6.39, 6.39, 6.39); Calibrated: 2014-02-25
- Sensor-Surface: 4mm (Mechanical Surface Detection)
- Electronics: DAE4 Sn1422; Calibrated: 2014-01-13
- Phantom: SAM Twin Phantom\_1800MHz; Type: SAM; Serial: TP-1433
- Measurement SW: DASY4, V4.7 Build 71; Postprocessing SW: SEMCAD, V1.8 Build 184

**Area Scan (61x111x1):** Measurement grid: dx=15mm, dy=15mm  
Maximum value of SAR (interpolated) = 0.488 mW/g  
**Zoom Scan (5x5x7)/Cube 0:** Measurement grid: dx=8mm, dy=8mm, dz=5mm  
Reference Value = 6.24 V/m; Power Drift = -0.140 dB  
Peak SAR (extrapolated) = 0.602 W/kg  
**SAR(1 g) = 0.459 mW/g; SAR(10 g) = 0.351 mW/g**  
Maximum value of SAR (measured) = 0.484 mW/g

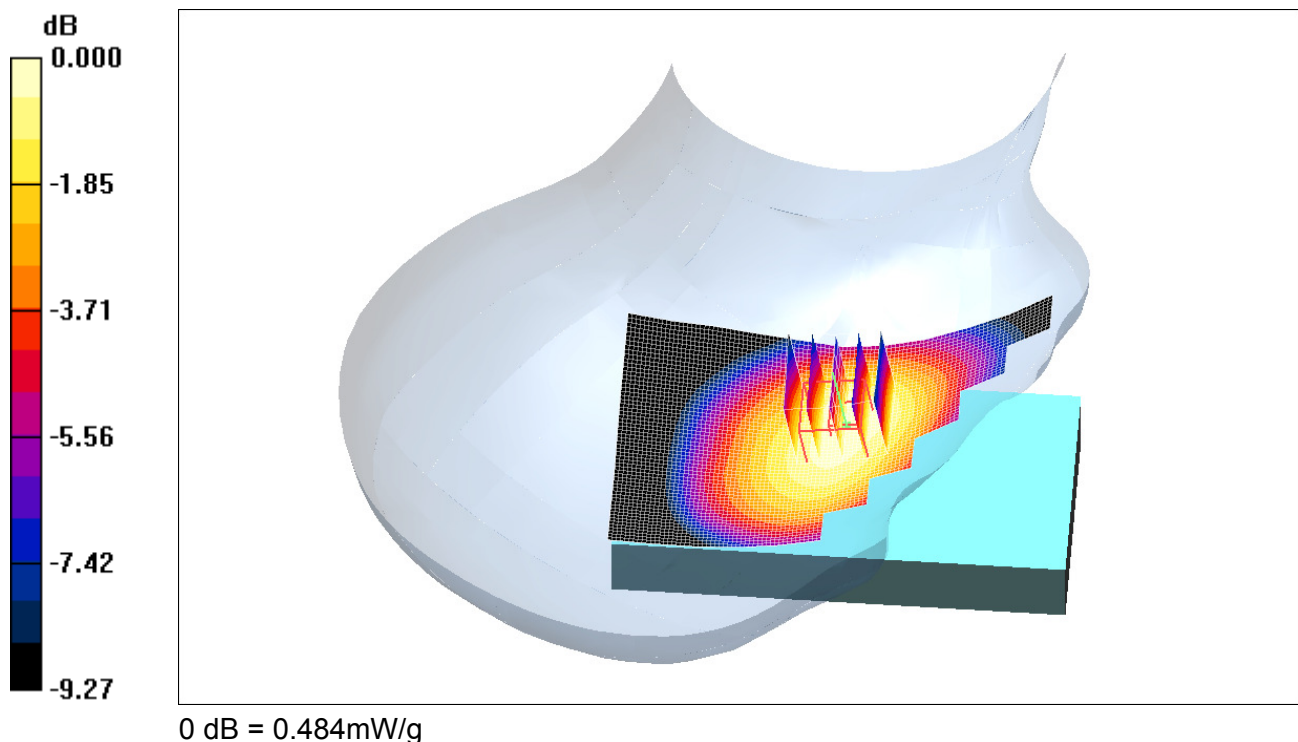

- Test Laboratory: KTL
- Model: NAUTIZ X4
- Position: GSM850 BODY REAR 1.5cm\_251CH
- Test Date: 05/12/2014
- Measured Liquid Temperature: 22.6 °C, Ambient Temperature: 22.1 °C

Communication System: GSM 850; Frequency: 848.8 MHz; Duty Cycle: 1:8.3  
Medium: MSL835 Medium parameters used:  $f = 848.8$  MHz;  $\sigma = 0.93$  mho/m;  $\epsilon_r = 53.8$ ;  $\rho = 1000$  kg/m<sup>3</sup>  
Phantom section: Flat Section  
Measurement Standard: DAS4 (High Precision Assessment)

DASY4 Configuration:

- Probe: ES3DV2 - SN3020; ConvF(6.17, 6.17, 6.17); Calibrated: 2014-02-25
- Sensor-Surface: 4mm (Mechanical Surface Detection)
- Electronics: DAE4 Sn1422; Calibrated: 2014-01-13
- Phantom: SAM Twin Phantom\_835MHz; Type: SAM; Serial: TP-1276
- Measurement SW: DAS4, V4.7 Build 71; Postprocessing SW: SEMCAD, V1.8 Build 184

**Area Scan (61x111x1):** Measurement grid: dx=15mm, dy=15mm  
Maximum value of SAR (interpolated) = 0.314 mW/g  
**Zoom Scan (5x5x7)/Cube 0:** Measurement grid: dx=8mm, dy=8mm, dz=5mm  
Reference Value = 17.6 V/m; Power Drift = -0.085 dB  
Peak SAR (extrapolated) = 0.376 W/kg  
**SAR(1 g) = 0.297 mW/g; SAR(10 g) = 0.227 mW/g**  
Maximum value of SAR (measured) = 0.312 mW/g

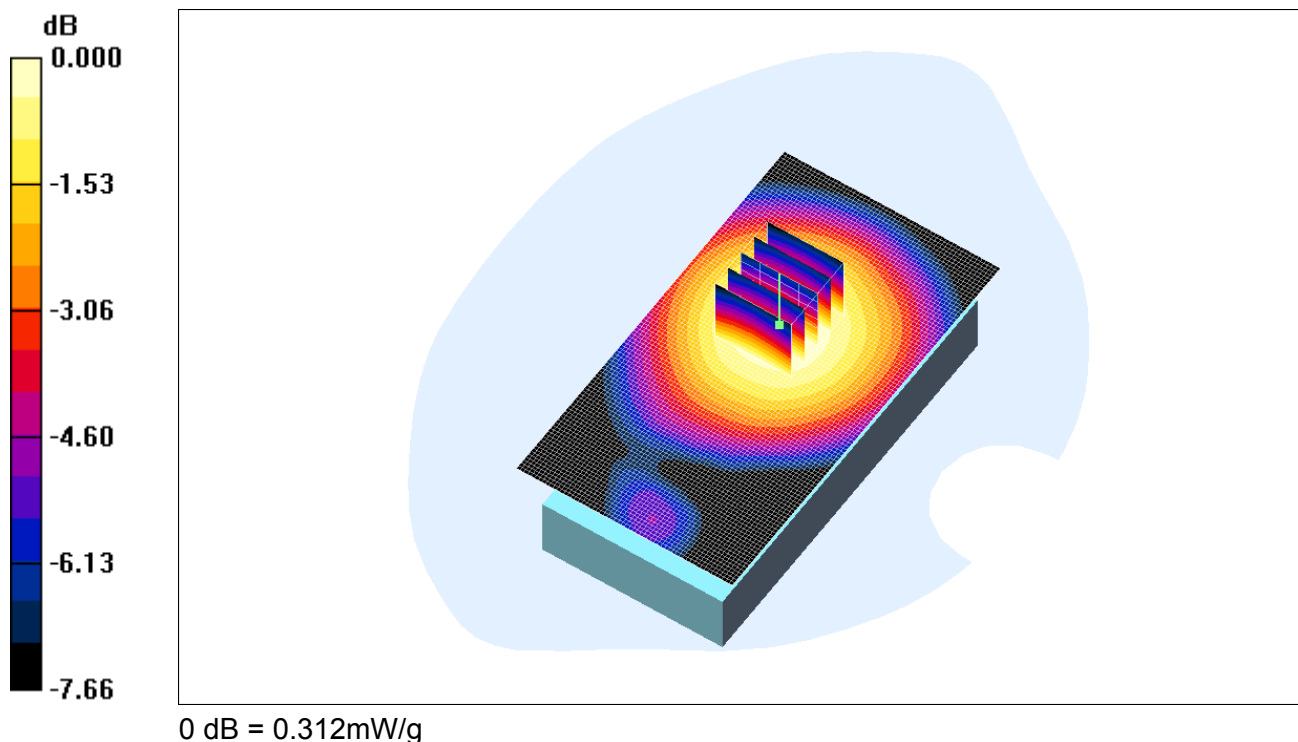



- Test Laboratory: KTL
- Model: NAUTIZ X4
- Position: GSM1900 LEFT CHEEK TOUCH\_661CH
- Test Date: 02/24/2014
- Measured Liquid Temperature: 22.3 °C, Ambient Temperature: 22.0 °C

Communication System: DCS 1900; Frequency: 1880 MHz; Duty Cycle: 1:8.3  
Medium: HSL1900 Medium parameters used:  $f = 1880$  MHz;  $\sigma = 1.36$  mho/m;  $\epsilon_r = 39.3$ ;  $\rho = 1000$  kg/m<sup>3</sup>  
Phantom section: Left Section  
Measurement Standard: DASY4 (High Precision Assessment)

DASY4 Configuration:

- Probe: EX3DV4 - SN3972; ConvF(7.81, 7.81, 7.81); Calibrated: 2014-01-28
- Sensor-Surface: 4mm (Mechanical Surface Detection)
- Electronics: DAE4 Sn1422; Calibrated: 2014-01-13
- Phantom: SAM Twin Phantom\_1800MHz; Type: SAM; Serial: TP-1433
- Measurement SW: DASY4, V4.7 Build 71; Postprocessing SW: SEMCAD, V1.8 Build 184

**Area Scan (61x111x1):** Measurement grid: dx=15mm, dy=15mm  
Maximum value of SAR (interpolated) = 0.082 mW/g

**Zoom Scan (5x5x7)/Cube 0:** Measurement grid: dx=8mm, dy=8mm, dz=5mm  
Reference Value = 3.92 V/m; Power Drift = 0.039 dB  
Peak SAR (extrapolated) = 0.112 W/kg  
**SAR(1 g) = 0.074 mW/g; SAR(10 g) = 0.048 mW/g**  
Maximum value of SAR (measured) = 0.080 mW/g

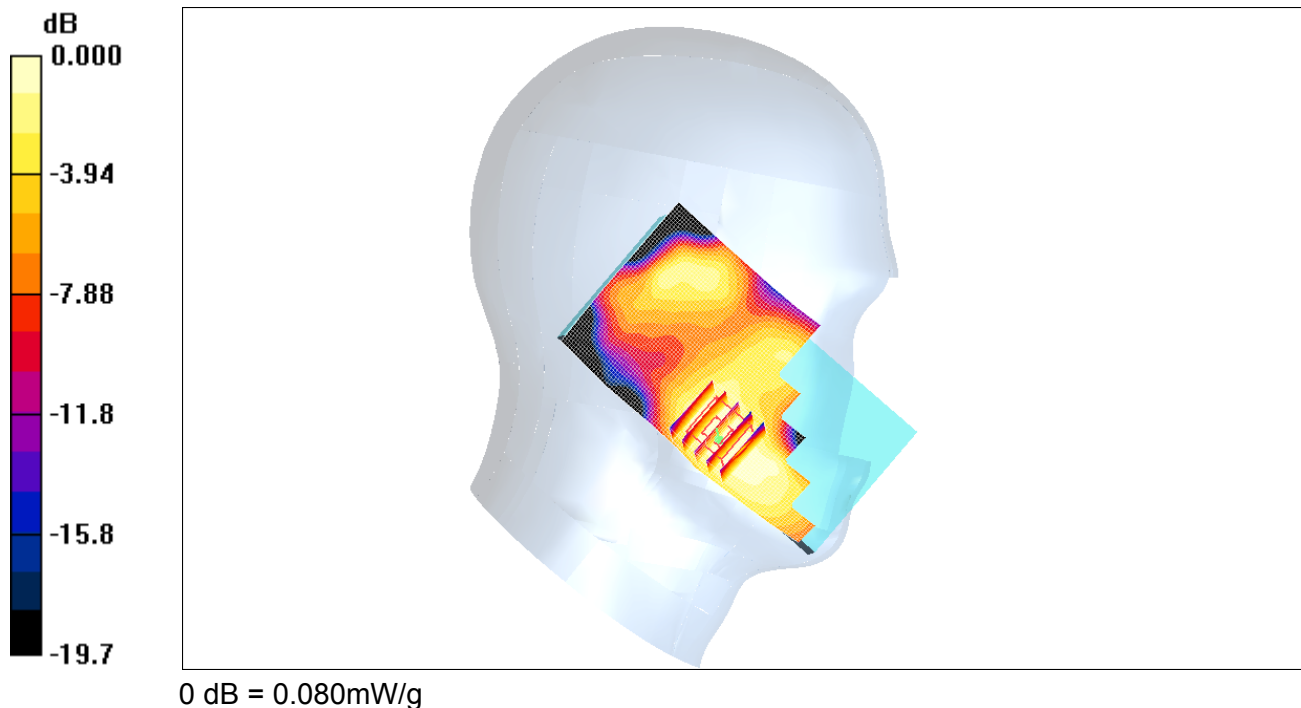

- Test Laboratory: KTL
- Model: NAUTIZ X4
- Position: GSM1900 BODY REAR 1.5cm\_661CH
- Test Date: 02/25/2014
- Measured Liquid Temperature: 22.2 °C, Ambient Temperature: 22.0 °C

Communication System: DCS 1900; Frequency: 1880 MHz; Duty Cycle: 1:8.3  
Medium: MSL1900 Medium parameters used:  $f = 1880$  MHz;  $\sigma = 1.51$  mho/m;  $\epsilon_r = 53$ ;  $\rho = 1000$  kg/m<sup>3</sup>  
Phantom section: Flat Section  
Measurement Standard: DASY4 (High Precision Assessment)

DASY4 Configuration:

- Probe: EX3DV4 - SN3972; ConvF(7.58, 7.58, 7.58); Calibrated: 2014-01-28
- Sensor-Surface: 4mm (Mechanical Surface Detection)
- Electronics: DAE4 Sn1422; Calibrated: 2014-01-13
- Phantom: SAM Twin Phantom\_1800MHz; Type: SAM; Serial: TP-1433
- Measurement SW: DASY4, V4.7 Build 71; Postprocessing SW: SEMCAD, V1.8 Build 184

**Area Scan (61x111x1):** Measurement grid: dx=15mm, dy=15mm  
Maximum value of SAR (interpolated) = 0.216 mW/g

**Zoom Scan (5x5x7)/Cube 0:** Measurement grid: dx=8mm, dy=8mm, dz=5mm  
Reference Value = 6.61 V/m; Power Drift = -0.082 dB  
Peak SAR (extrapolated) = 0.293 W/kg  
**SAR(1 g) = 0.197 mW/g; SAR(10 g) = 0.127 mW/g**  
Maximum value of SAR (measured) = 0.212 mW/g

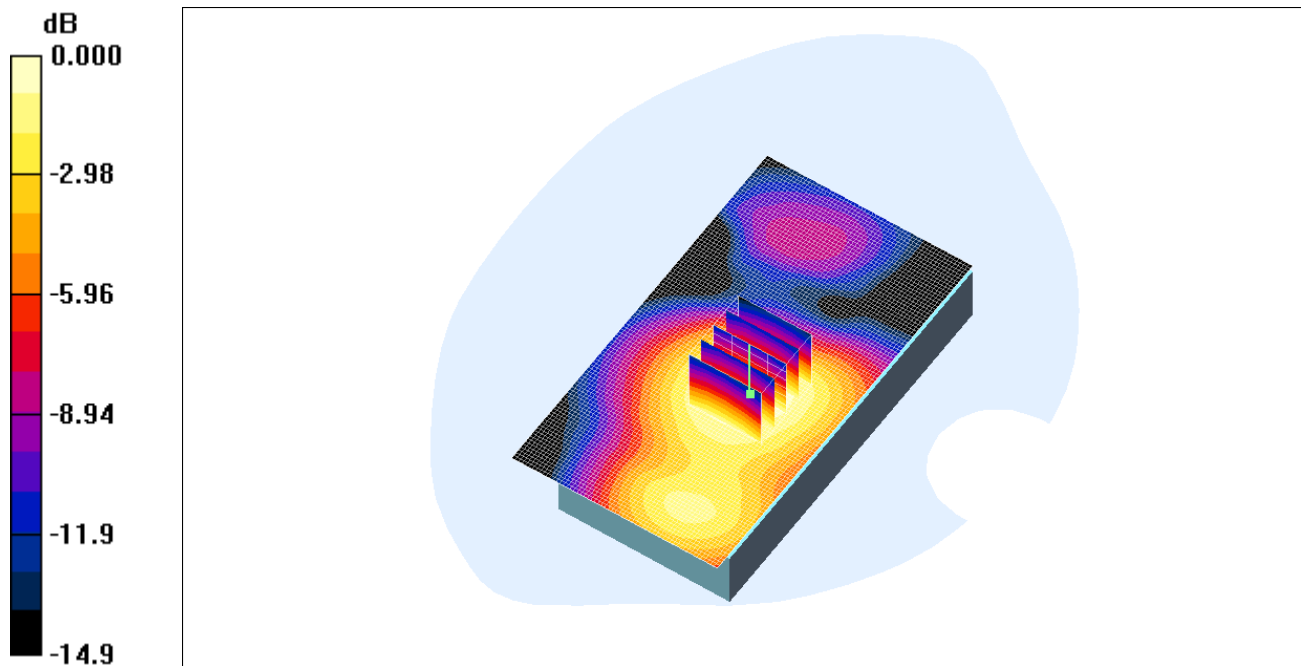

- Test Laboratory: KTL
- Model: NAUTIZ X4
- Position: WCDMA850 RIGHT CHEEK TOUCH\_4188CH
- Test Date: 05/12/2014
- Measured Liquid Temperature: 22.3 °C, Ambient Temperature: 22.0 °C

Communication System: WCDMA BAND5; Frequency: 846.6 MHz; Duty Cycle: 1:1  
Medium: HSL835 Medium parameters used:  $f = 846.6$  MHz;  $\sigma = 0.93$  mho/m;  $\epsilon_r = 42.1$ ;  $\rho = 1000$  kg/m<sup>3</sup>  
Phantom section: Right Section  
Measurement Standard: DASY4 (High Precision Assessment)

DASY4 Configuration:

- Probe: ES3DV2 - SN3020; ConvF(6.39, 6.39, 6.39); Calibrated: 2014-02-25
- Sensor-Surface: 4mm (Mechanical Surface Detection)
- Electronics: DAE4 Sn1422; Calibrated: 2014-01-13
- Phantom: SAM Twin Phantom\_1800MHz; Type: SAM; Serial: TP-1433
- Measurement SW: DASY4, V4.7 Build 71; Postprocessing SW: SEMCAD, V1.8 Build 184

**Area Scan (61x111x1):** Measurement grid: dx=15mm, dy=15mm  
Maximum value of SAR (interpolated) = 0.506 mW/g  
**Zoom Scan (5x5x7)/Cube 0:** Measurement grid: dx=8mm, dy=8mm, dz=5mm  
Reference Value = 5.32 V/m; Power Drift = 0.036 dB  
Peak SAR (extrapolated) = 0.643 W/kg  
**SAR(1 g) = 0.484 mW/g; SAR(10 g) = 0.370 mW/g**  
Maximum value of SAR (measured) = 0.506 mW/g

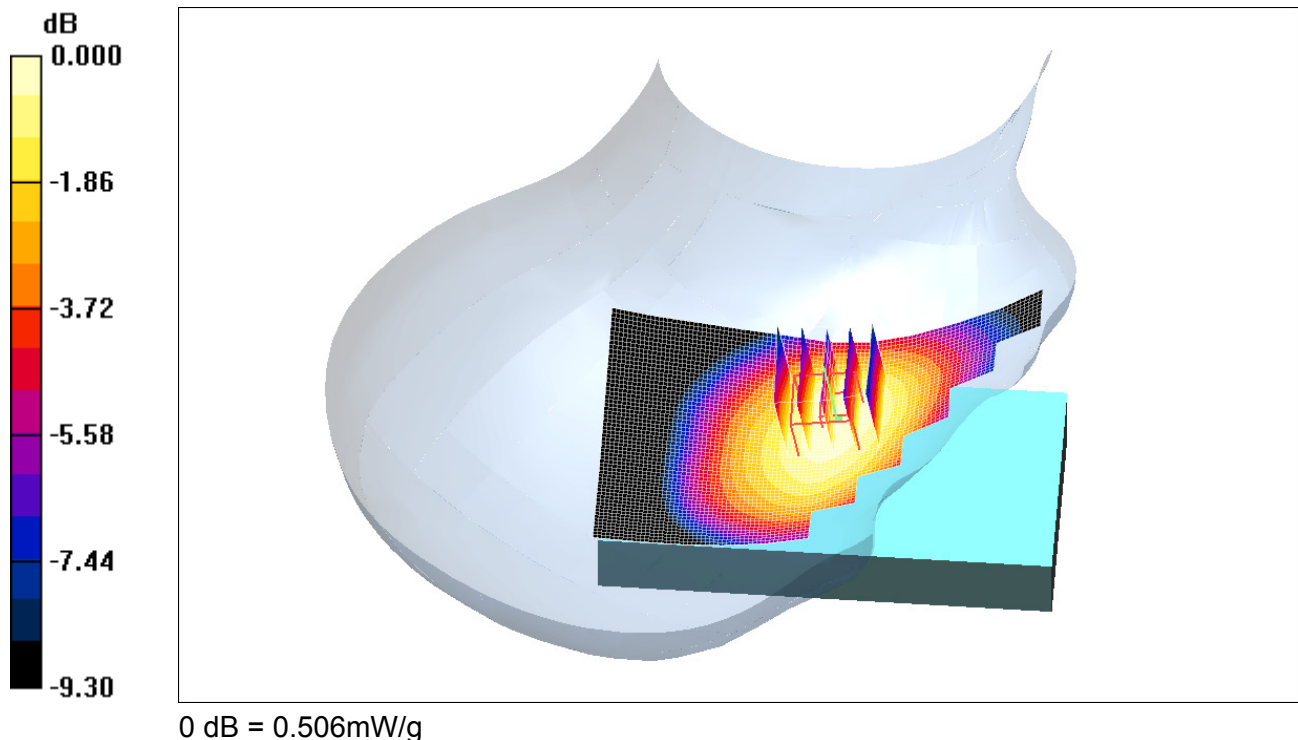

- Test Laboratory: KTL
- Model: NAUTIZ X4
- Position: WCDMA850 BODY REAR 1.5cm\_HIGH
- Test Date: 05/12/2014
- Measured Liquid Temperature: 22.6 °C, Ambient Temperature: 22.0 °C

Communication System: WCDMA BAND5; Frequency: 846.6 MHz; Duty Cycle: 1:1  
Medium: MSL835 Medium parameters used:  $f = 846.6$  MHz;  $\sigma = 0.93$  mho/m;  $\epsilon_r = 53.8$ ;  $\rho = 1000$  kg/m<sup>3</sup>  
Phantom section: Flat Section  
Measurement Standard: DASY4 (High Precision Assessment)

DASY4 Configuration:

- Probe: ES3DV2 - SN3020; ConvF(6.17, 6.17, 6.17); Calibrated: 2014-02-25
- Sensor-Surface: 4mm (Mechanical Surface Detection)
- Electronics: DAE4 Sn1422; Calibrated: 2014-01-13
- Phantom: SAM Twin Phantom\_835MHz; Type: SAM; Serial: TP-1276
- Measurement SW: DASY4, V4.7 Build 71; Postprocessing SW: SEMCAD, V1.8 Build 184

**Area Scan (61x111x1):** Measurement grid: dx=15mm, dy=15mm  
Maximum value of SAR (interpolated) = 0.355 mW/g  
**Zoom Scan (5x5x7)/Cube 0:** Measurement grid: dx=8mm, dy=8mm, dz=5mm  
Reference Value = 18.5 V/m; Power Drift = -0.081 dB  
Peak SAR (extrapolated) = 0.425 W/kg  
**SAR(1 g) = 0.331 mW/g; SAR(10 g) = 0.252 mW/g**  
Maximum value of SAR (measured) = 0.347 mW/g

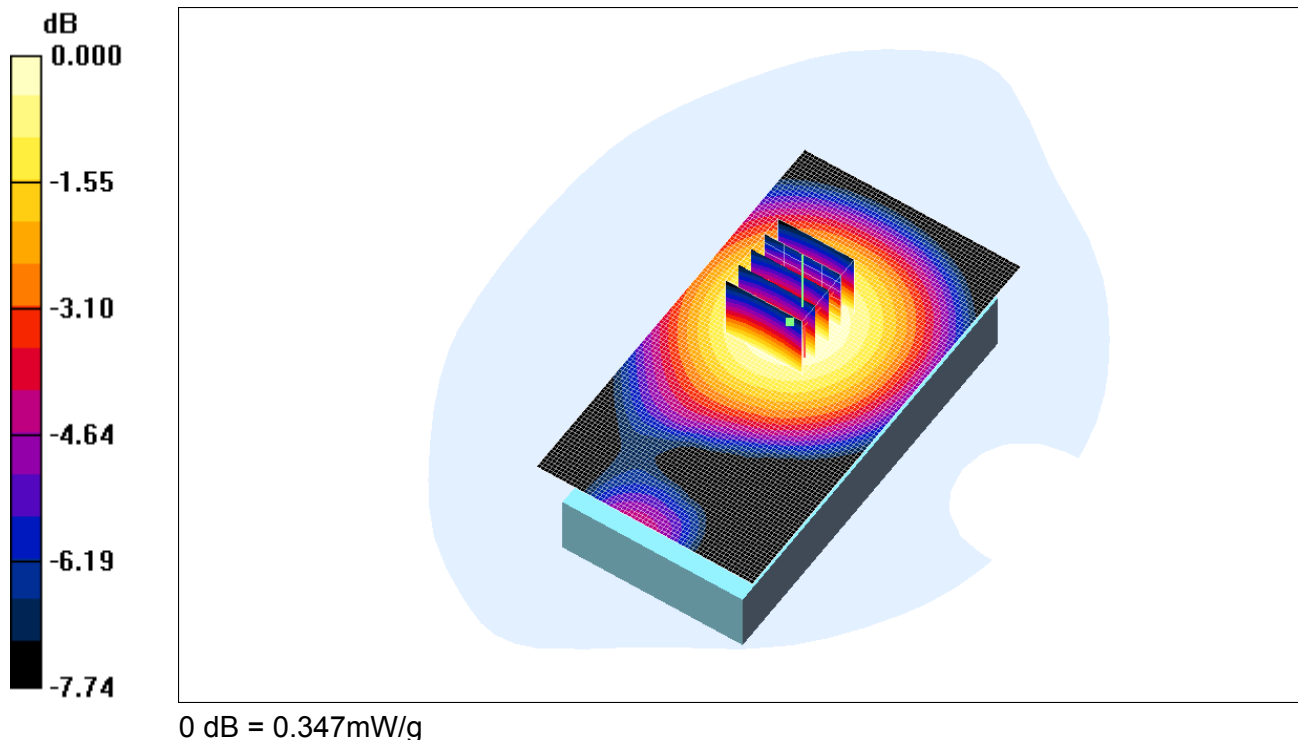

- Test Laboratory: KTL
- Model: NAUTIZ X4
- Position: WCDMA1900 LEFT CHEEK TOUCH\_9400CH
- Test Date: 02/24/2014
- Measured Liquid Temperature: 22.3 °C, Ambient Temperature: 22.0 °C

Communication System: WCDMA ; Frequency: 1880 MHz;Duty Cycle: 1:1  
Medium: HSL1900 Medium parameters used:  $f = 1880$  MHz;  $\sigma = 1.38$  mho/m;  $\epsilon_r = 39.3$ ;  $\rho = 1000$  kg/m<sup>3</sup>  
Phantom section: Left Section  
Measurement Standard: DASY4 (High Precision Assessment)

DASY4 Configuration:

- Probe: EX3DV4 - SN3972; ConvF(7.81, 7.81, 7.81); Calibrated: 2014-01-28
- Sensor-Surface: 4mm (Mechanical Surface Detection)
- Electronics: DAE4 Sn1422; Calibrated: 2014-01-13
- Phantom: SAM Twin Phantom\_1800MHz; Type: SAM; Serial: TP-1433
- Measurement SW: DASY4, V4.7 Build 71; Postprocessing SW: SEMCAD, V1.8 Build 184

**Area Scan (61x111x1):** Measurement grid: dx=15mm, dy=15mm  
Maximum value of SAR (interpolated) = 0.164 mW/g  
**Zoom Scan (5x5x7)/Cube 0:** Measurement grid: dx=8mm, dy=8mm, dz=5mm  
Reference Value = 6.00 V/m; Power Drift = -0.149 dB  
Peak SAR (extrapolated) = 0.212 W/kg  
**SAR(1 g) = 0.138 mW/g; SAR(10 g) = 0.089 mW/g**  
Maximum value of SAR (measured) = 0.149 mW/g

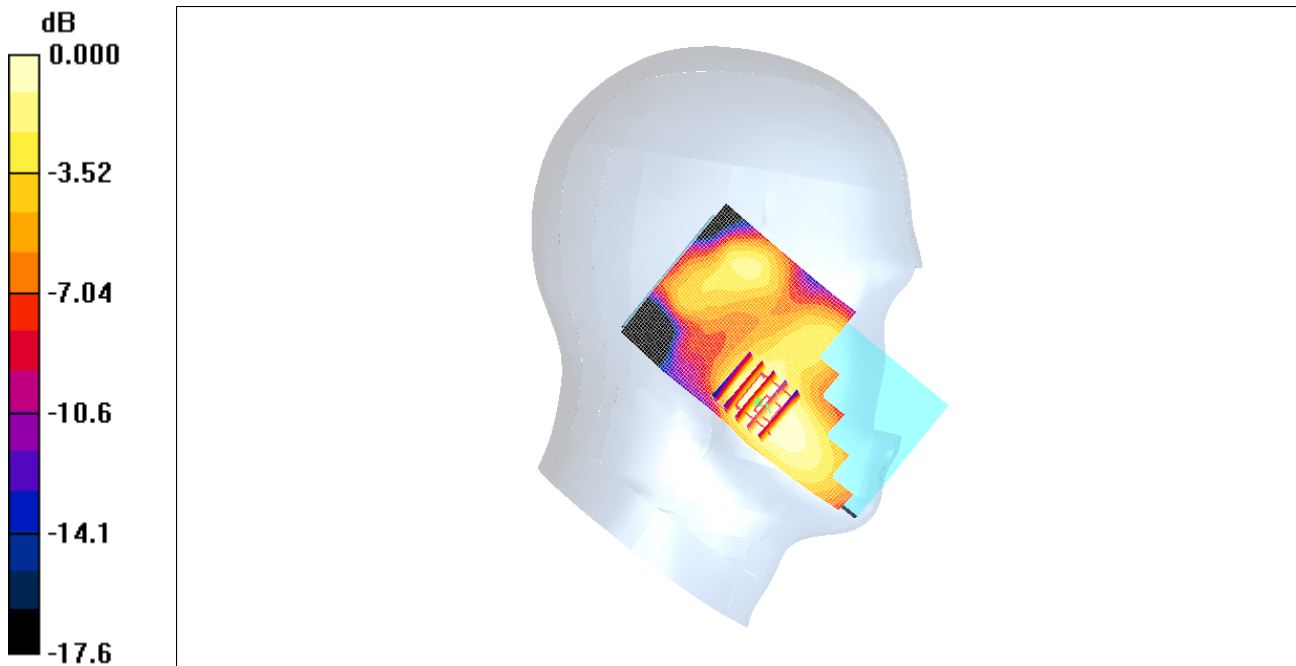

0 dB = 0.149mW/g

- Test Laboratory: KTL
- Model: NAUTIZ X4
- Position: WCDMA1900 BODY REAR 1.5cm\_9400CH
- Test Date: 02/25/2014
- Measured Liquid Temperature: 22.2 °C, Ambient Temperature: 22.0 °C

Communication System: WCDMA ; Frequency: 1880 MHz;Duty Cycle: 1:1  
Medium: MSL1900 Medium parameters used:  $f = 1880$  MHz;  $\sigma = 1.53$  mho/m;  $\epsilon_r = 53$ ;  $\rho = 1000$  kg/m<sup>3</sup>  
Phantom section: Flat Section  
Measurement Standard: DASY4 (High Precision Assessment)

DASY4 Configuration:

- Probe: EX3DV4 - SN3972; ConvF(7.58, 7.58, 7.58); Calibrated: 2014-01-28
- Sensor-Surface: 4mm (Mechanical Surface Detection)
- Electronics: DAE4 Sn1422; Calibrated: 2014-01-13
- Phantom: SAM Twin Phantom\_1800MHz; Type: SAM; Serial: TP-1433
- Measurement SW: DASY4, V4.7 Build 71; Postprocessing SW: SEMCAD, V1.8 Build 184

**Area Scan (61x111x1):** Measurement grid: dx=15mm, dy=15mm  
Maximum value of SAR (interpolated) = 0.425 mW/g  
**Zoom Scan (5x5x7)/Cube 0:** Measurement grid: dx=8mm, dy=8mm, dz=5mm  
Reference Value = 9.47 V/m; Power Drift = -0.155 dB  
Peak SAR (extrapolated) = 0.575 W/kg  
**SAR(1 g) = 0.384 mW/g; SAR(10 g) = 0.247 mW/g**  
Maximum value of SAR (measured) = 0.411 mW/g

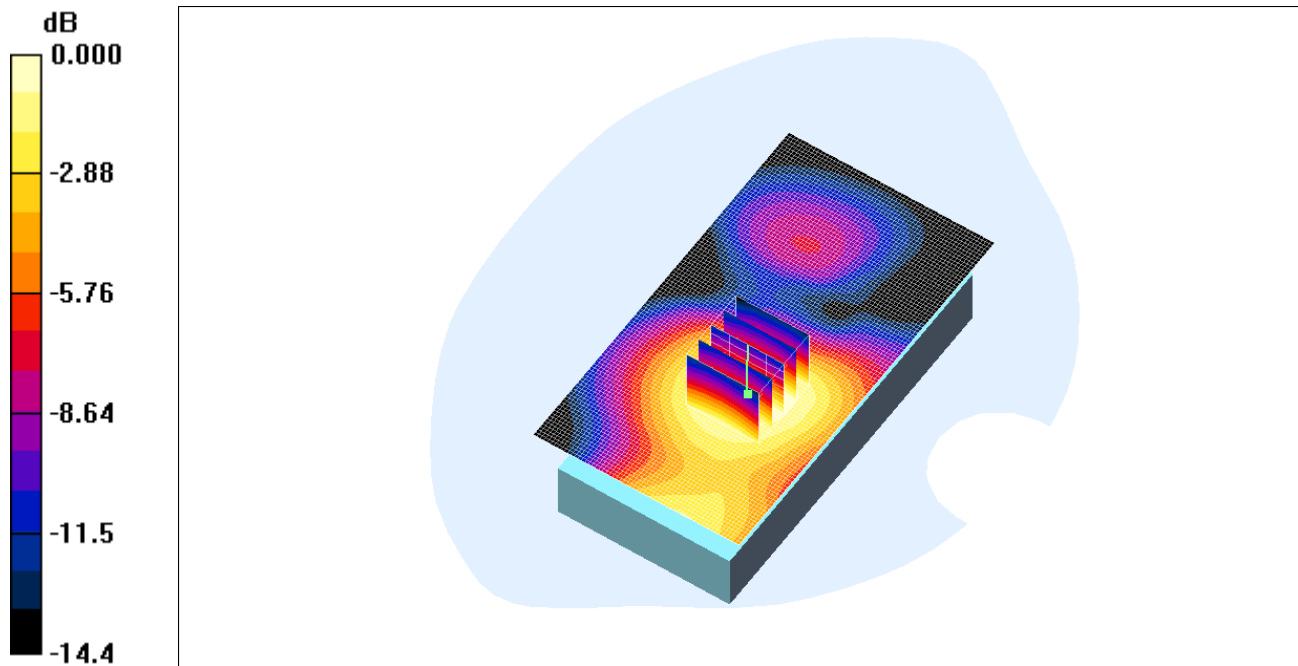

0 dB = 0.411mW/g



- Test Laboratory: KTL
- Model: NAUTIZ X4
- Position: 802.11b 2437 LEFT CHEEK TOUCH\_6CH
- Test Date: 02/27/2014
- Measured Liquid Temperature: 22.6 °C, Ambient Temperature: 21.0 °C

Communication System: WLAN; Frequency: 2437 MHz; Duty Cycle: 1:1  
Medium: 2450D Medium parameters used:  $f = 2437$  MHz;  $\sigma = 1.86$  mho/m;  $\epsilon_r = 38.7$ ;  $\rho = 1000$  kg/m<sup>3</sup>  
Phantom section: Left Section  
Measurement Standard: DASY4 (High Precision Assessment)

DASY4 Configuration:

- Probe: EX3DV4 - SN3972; ConvF(7.09, 7.09, 7.09); Calibrated: 2014-01-28
- Sensor-Surface: 4mm (Mechanical Surface Detection)
- Electronics: DAE4 Sn1422; Calibrated: 2014-01-13
- Phantom: SAM Twin Phantom\_1800MHz; Type: SAM; Serial: TP-1433
- Measurement SW: DASY4, V4.7 Build 71; Postprocessing SW: SEMCAD, V1.8 Build 184

**Area Scan (61x111x1):** Measurement grid: dx=15mm, dy=15mm  
Maximum value of SAR (interpolated) = 0.134 mW/g  
**Zoom Scan (5x5x7)/Cube 0:** Measurement grid: dx=8mm, dy=8mm, dz=5mm  
Reference Value = 3.33 V/m; Power Drift = -0.099 dB  
Peak SAR (extrapolated) = 0.281 W/kg  
**SAR(1 g) = 0.138 mW/g; SAR(10 g) = 0.064 mW/g**  
Maximum value of SAR (measured) = 0.143 mW/g

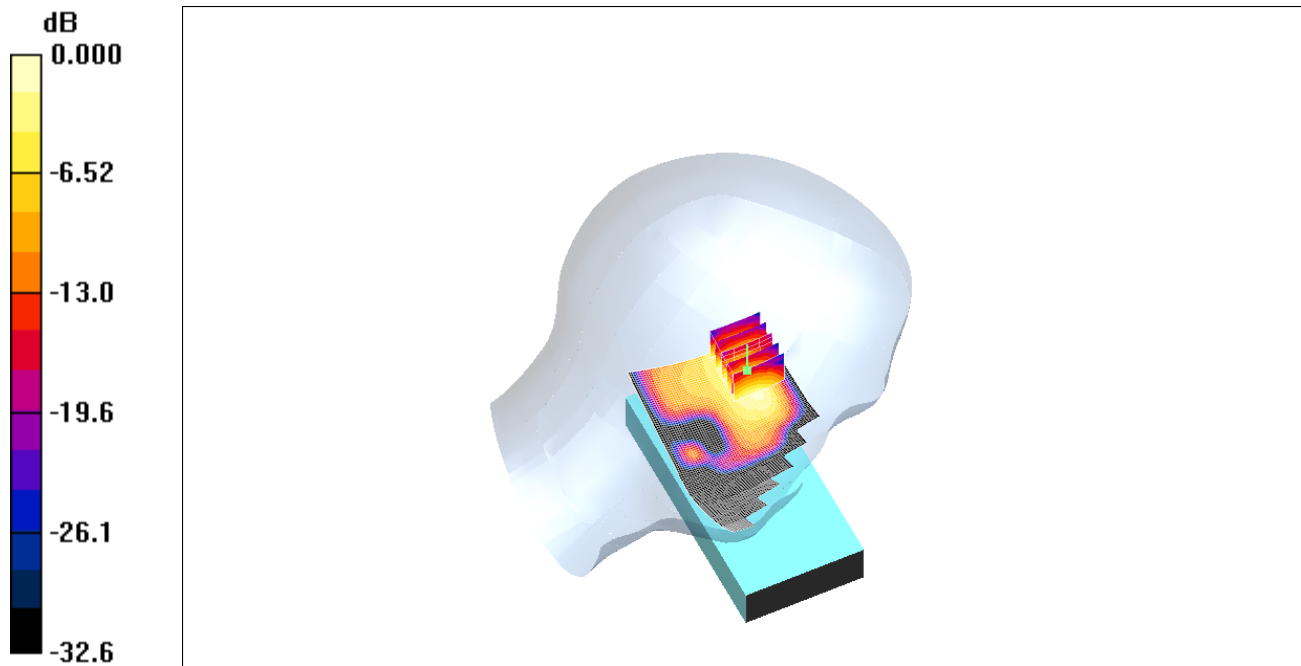

- Test Laboratory: KTL
- Model: NAUTIZ X4
- Position: 802.11b 2412 BODY FRONT 1.5cm
- Test Date: 02/28/2014
- Measured Liquid Temperature: 22.8 °C, Ambient Temperature: 23.0 °C

Communication System: WLAN; Frequency: 2437 MHz; Duty Cycle: 1:1  
Medium: 2450D Medium parameters used:  $f = 2437$  MHz;  $\sigma = 1.92$  mho/m;  $\epsilon_r = 52.2$ ;  $\rho = 1000$  kg/m<sup>3</sup>  
Phantom section: Flat Section  
Measurement Standard: DASY4 (High Precision Assessment)

DASY4 Configuration:

- Probe: EX3DV4 - SN3972; ConvF(7.24, 7.24, 7.24); Calibrated: 2014-01-28
- Sensor-Surface: 4mm (Mechanical Surface Detection)
- Electronics: DAE4 Sn1422; Calibrated: 2014-01-13
- Phantom: SAM Twin Phantom\_1800MHz; Type: SAM; Serial: TP-1433
- Measurement SW: DASY4, V4.7 Build 71; Postprocessing SW: SEMCAD, V1.8 Build 184

**Area Scan (61x111x1):** Measurement grid: dx=15mm, dy=15mm  
Maximum value of SAR (interpolated) = 0.148 mW/g  
**Zoom Scan (5x5x7)/Cube 0:** Measurement grid: dx=8mm, dy=8mm, dz=5mm  
Reference Value = 1.30 V/m; Power Drift = -0.166 dB  
Peak SAR (extrapolated) = 0.205 W/kg  
**SAR(1 g) = 0.101 mW/g; SAR(10 g) = 0.047 mW/g**  
Maximum value of SAR (measured) = 0.116 mW/g

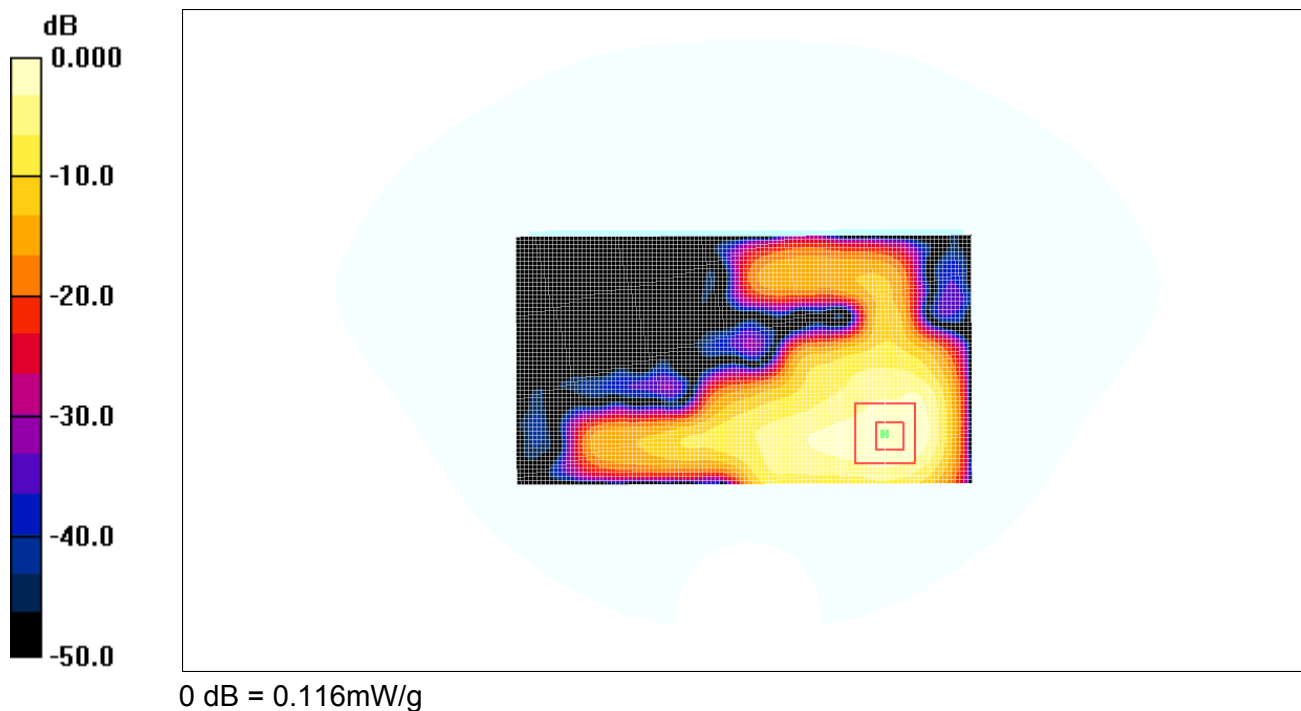



**835 MHz Head – Verification DATA (D835V2 – 481)**

- Test Date: 02/21/2014

- Measured Liquid Temperature: 22.5 °C, Ambient Temperature: 22.1 °C

Communication System: CW; Frequency: 835 MHz; Duty Cycle: 1:1

Medium: HSL835 Medium parameters used:  $f = 835 \text{ MHz}$ ;  $\sigma = 0.91 \text{ mho/m}$ ;  $\epsilon_r = 42.2$ ;  $\rho = 1000 \text{ kg/m}^3$

Phantom section: Flat Section

Measurement Standard: DASY4 (High Precision Assessment)

DASY4 Configuration:

- Probe: EX3DV4 - SN3972; ConvF(9.75, 9.75, 9.75); Calibrated: 2014-01-28
- Sensor-Surface: 4mm (Mechanical Surface Detection) Sensor-Surface: 0mm (Fix Surface)
- Electronics: DAE4 Sn1422; Calibrated: 2014-01-13
- Phantom: SAM Twin Phantom\_835MHz; Type: SAM; Serial: TP-1276
- Measurement SW: DASY4, V4.7 Build 71; Postprocessing SW: SEMCAD, V1.8 Build 184

**835 Validation/Area Scan (61x91x1):** Measurement grid:  $dx=20\text{mm}$ ,  $dy=20\text{mm}$

Maximum value of SAR (interpolated) = 2.84 mW/g

**835 Validation/Z Scan (1x1x16):** Measurement grid:  $dx=20\text{mm}$ ,  $dy=20\text{mm}$ ,  $dz=20\text{mm}$

Maximum value of SAR (interpolated) = 1.71 mW/g

**835 Validation/Zoom Scan (5x5x7)/Cube 0:** Measurement grid:  $dx=8\text{mm}$ ,  $dy=8\text{mm}$ ,  $dz=5\text{mm}$

Reference Value = 56.0 V/m; Power Drift = -0.114 dB

Peak SAR (extrapolated) = 3.81 W/kg

**SAR(1 g) = 2.57 mW/g; SAR(10 g) = 1.68 mW/g**

Maximum value of SAR (measured) = 2.77 mW/g

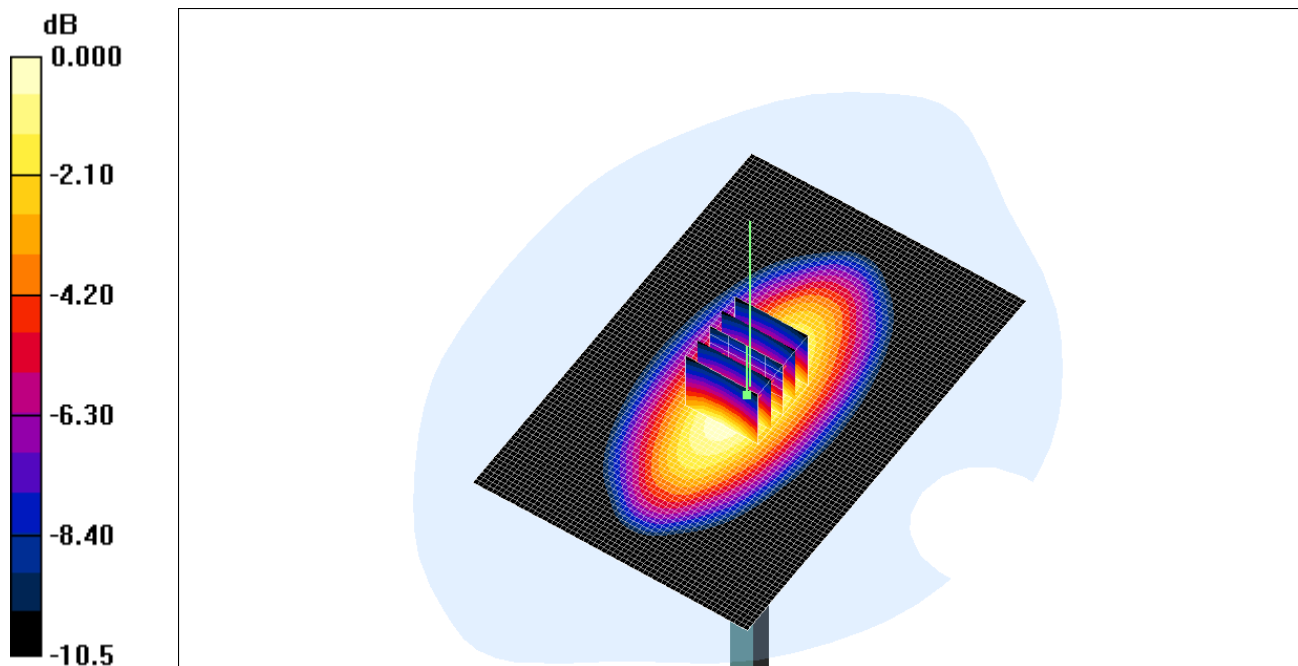

0 dB = 2.77mW/g

**835 MHz Head – Verification DATA (D835V2 – 481)**

- Test Date: 05/12/2014

- Measured Liquid Temperature: 22.3 °C, Ambient Temperature: 22.1 °C

Communication System: CW; Frequency: 835 MHz; Duty Cycle: 1:1

Medium: HSL835 Medium parameters used:  $f = 835 \text{ MHz}$ ;  $\sigma = 0.91 \text{ mho/m}$ ;  $\epsilon_r = 42.2$ ;  $\rho = 1000 \text{ kg/m}^3$

Phantom section: Flat Section

Measurement Standard: DASY4 (High Precision Assessment)

DASY4 Configuration:

- Probe: ES3DV2 - SN3020; ConvF(6.39, 6.39, 6.39); Calibrated: 2014-02-25
- Sensor-Surface: 4mm (Mechanical Surface Detection) Sensor-Surface: 0mm (Fix Surface)
- Electronics: DAE4 Sn1422; Calibrated: 2014-01-13
- Phantom: SAM Twin Phantom\_1800MHz; Type: SAM; Serial: TP-1433
- Measurement SW: DASY4, V4.7 Build 71; Postprocessing SW: SEMCAD, V1.8 Build 184

**835 Validation/Area Scan (61x91x1):** Measurement grid: dx=20mm, dy=20mm

Maximum value of SAR (interpolated) = 2.82 mW/g

**835 Validation/Z Scan (1x1x16):** Measurement grid: dx=20mm, dy=20mm, dz=20mm

Maximum value of SAR (interpolated) = 1.20 mW/g

**835 Validation/Zoom Scan (5x5x7)/Cube 0:** Measurement grid: dx=8mm, dy=8mm, dz=5mm

Reference Value = 56.0 V/m; Power Drift = -0.025 dB

Peak SAR (extrapolated) = 3.80 W/kg

**SAR(1 g) = 2.59 mW/g; SAR(10 g) = 1.7 mW/g**

Maximum value of SAR (measured) = 2.81 mW/g

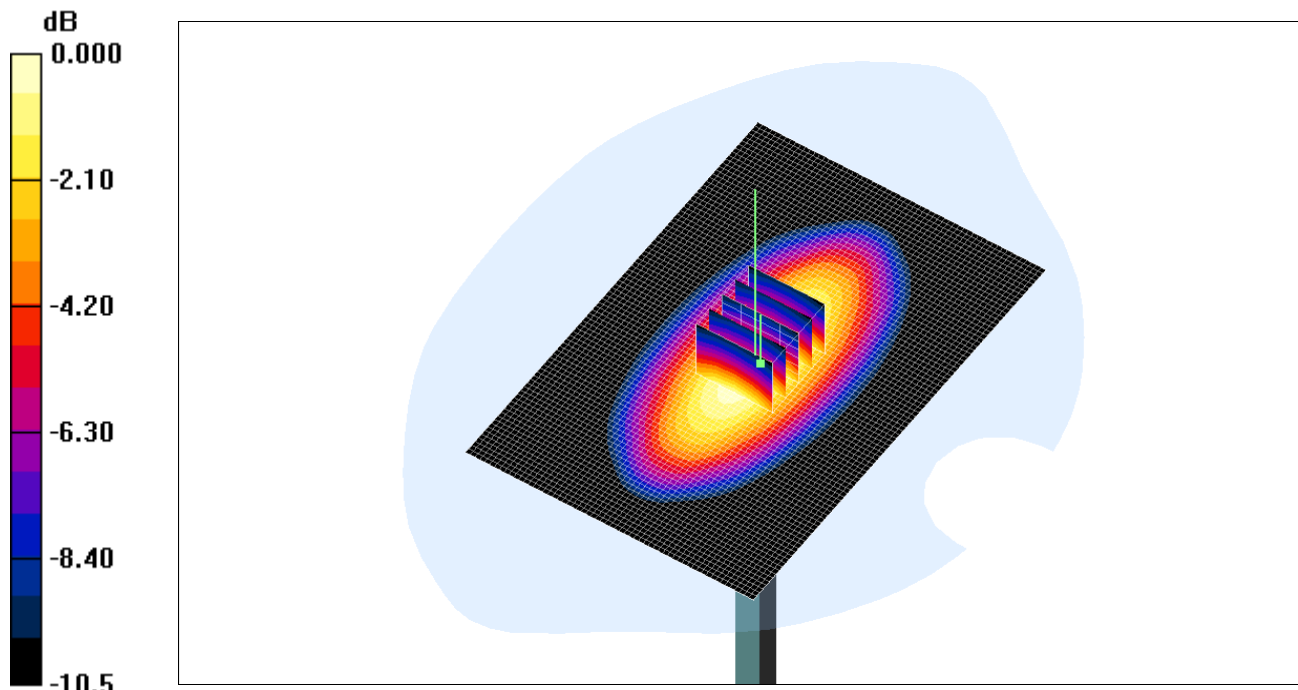

0 dB = 2.81mW/g

**835 MHz Body- Verification DATA (D83.5V2 – 481)**

**- Test Date: 05/12/2014**

**- Measured Liquid Temperature: 22.6 °C, Ambient Temperature: 22.0 °C**

Communication System: CW; Frequency: 835 MHz; Duty Cycle: 1:1

Medium: MSL835 Medium parameters used:  $f = 835 \text{ MHz}$ ;  $\sigma = 0.92 \text{ mho/m}$ ;  $\epsilon_r = 53.7$ ;  $\rho = 1000 \text{ kg/m}^3$

Phantom section: Flat Section

Measurement Standard: DASY4 (High Precision Assessment)

DASY4 Configuration:

- Probe: ES3DV2 - SN3020; ConvF(6.17, 6.17, 6.17); Calibrated: 2014-02-25
- Sensor-Surface: 4mm (Mechanical Surface Detection) Sensor-Surface: 0mm (Fix Surface)
- Electronics: DAE4 Sn1422; Calibrated: 2014-01-13
- Phantom: SAM Twin Phantom\_835MHz; Type: SAM; Serial: TP-1276
- Measurement SW: DASY4, V4.7 Build 71; Postprocessing SW: SEMCAD, V1.8 Build 184

**835 Validation/Area Scan (61x91x1):** Measurement grid:  $dx=20\text{mm}$ ,  $dy=20\text{mm}$

Maximum value of SAR (interpolated) = 2.85 mW/g

**835 Validation/Z Scan (1x1x16):** Measurement grid:  $dx=20\text{mm}$ ,  $dy=20\text{mm}$ ,  $dz=20\text{mm}$

Maximum value of SAR (interpolated) = 1.50 mW/g

**835 Validation/Zoom Scan (5x5x7)/Cube 0:** Measurement grid:  $dx=8\text{mm}$ ,  $dy=8\text{mm}$ ,  $dz=5\text{mm}$

Reference Value = 55.4 V/m; Power Drift = -0.015 dB

Peak SAR (extrapolated) = 3.79 W/kg

**SAR(1 g) = 2.58 mW/g; SAR(10 g) = 1.71 mW/g**

Maximum value of SAR (measured) = 2.78 mW/g

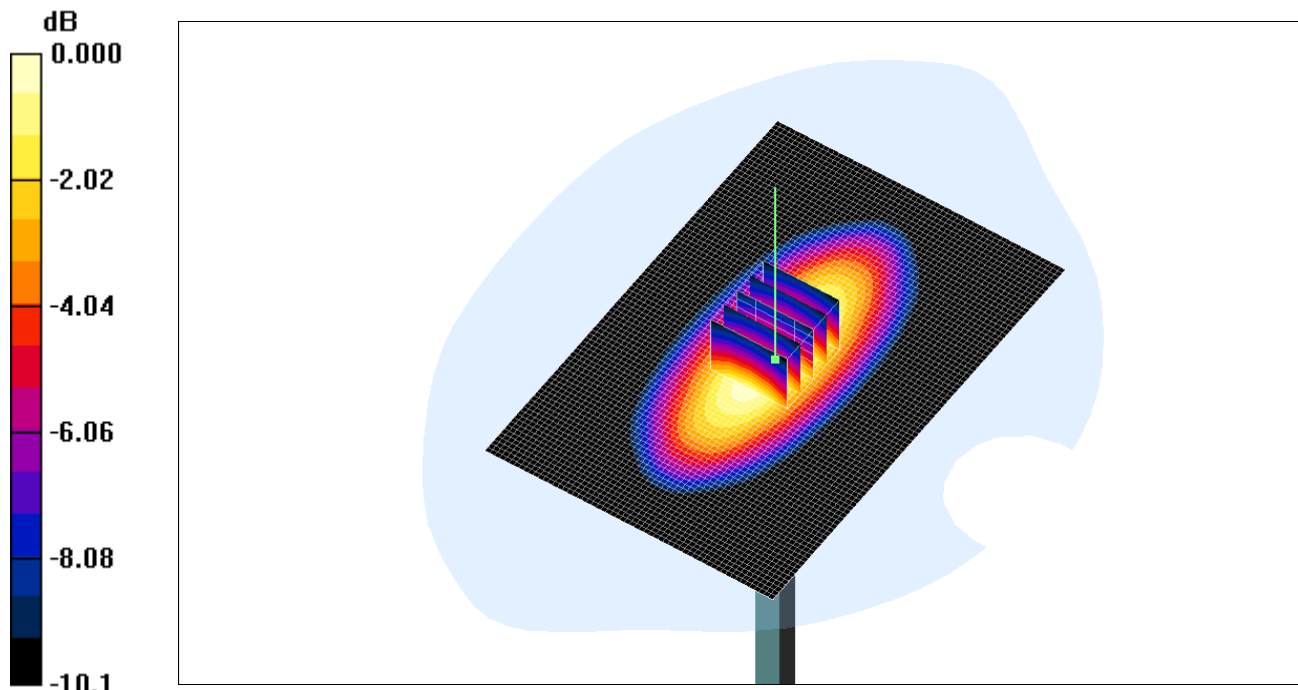

0 dB = 2.78mW/g

**1900 MHz Head- Verification DATA (D1900V2 – 5d038)**

**- Test Date: 02/24/2014**

**- Measured Liquid Temperature: 22.3 °C, Ambient Temperature: 22.0 °C**

Communication System: CW; Frequency: 1900 MHz; Duty Cycle: 1:1

Medium: HSL1900 Medium parameters used:  $f = 1900 \text{ MHz}$ ;  $\sigma = 1.38 \text{ mho/m}$ ;  $\epsilon_r = 39.3$ ;  $\rho = 1000 \text{ kg/m}^3$

Phantom section: Flat Section

Measurement Standard: DASY4 (High Precision Assessment)

DASY4 Configuration:

- Probe: EX3DV4 - SN3972; ConvF(7.81, 7.81, 7.81); Calibrated: 2014-01-28
- Sensor-Surface: 4mm (Mechanical Surface Detection) Sensor-Surface: 0mm (Fix Surface)
- Electronics: DAE4 Sn1422; Calibrated: 2014-01-13
- Phantom: SAM Twin Phantom\_1800MHz; Type: SAM; Serial: TP-1433
- Measurement SW: DASY4, V4.7 Build 71; Postprocessing SW: SEMCAD, V1.8 Build 184

**1900 Validation /Area Scan (61x71x1):** Measurement grid:  $dx=15\text{mm}$ ,  $dy=15\text{mm}$

Maximum value of SAR (interpolated) = 12.2 mW/g

**1900 Validation /Z Scan (1x1x16):** Measurement grid:  $dx=20\text{mm}$ ,  $dy=20\text{mm}$ ,  $dz=20\text{mm}$

Maximum value of SAR (interpolated) = 3.32 mW/g

**1900 Validation /Zoom Scan (7x7x7)/Cube 0:** Measurement grid:  $dx=5\text{mm}$ ,  $dy=5\text{mm}$ ,  $dz=5\text{mm}$

Reference Value = 89.4 V/m; Power Drift = -0.022 dB

Peak SAR (extrapolated) = 18.4 W/kg

**SAR(1 g) = 9.89 mW/g; SAR(10 g) = 5.16 mW/g**

Maximum value of SAR (measured) = 11.1 mW/g

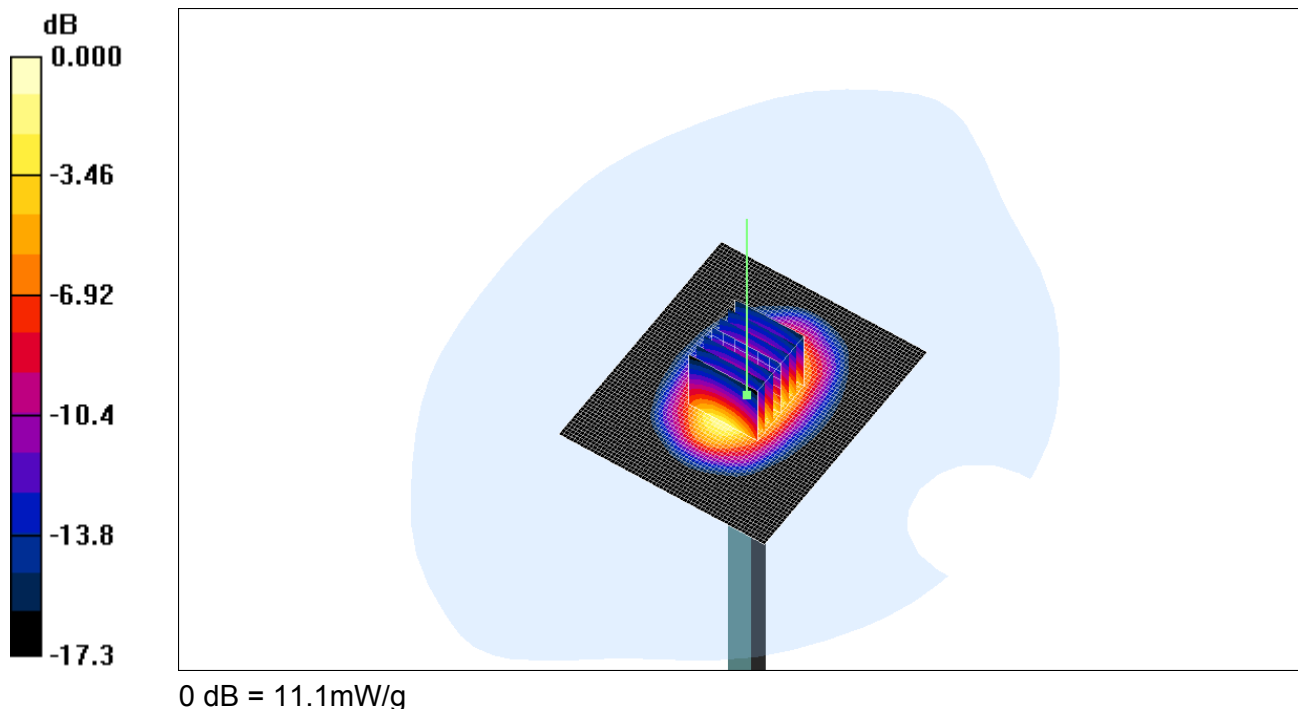

**1900 MHz Head- Verification DATA (D1900V2 – 5d038)**

**- Test Date: 05/13/2014**

**- Measured Liquid Temperature: 22.5 °C, Ambient Temperature: 22.0 °C**

Communication System: CW; Frequency: 1900 MHz; Duty Cycle: 1:1

Medium: HSL1900 Medium parameters used:  $f = 1900$  MHz;  $\sigma = 1.37$  mho/m;  $\epsilon_r = 39.4$ ;  $\rho = 1000$  kg/m<sup>3</sup>

Phantom section: Flat Section

Measurement Standard: DASY4 (High Precision Assessment)

DASY4 Configuration:

- Probe: ES3DV2 - SN3020; ConvF(4.85, 4.85, 4.85); Calibrated: 2014-02-25
- Sensor-Surface: 4mm (Mechanical Surface Detection) Sensor-Surface: 0mm (Fix Surface)
- Electronics: DAE4 Sn1422; Calibrated: 2014-01-13
- Phantom: SAM Twin Phantom\_1800MHz; Type: SAM; Serial: TP-1433
- Measurement SW: DASY4, V4.7 Build 71; Postprocessing SW: SEMCAD, V1.8 Build 184

**1900 Validation /Area Scan (61x71x1):** Measurement grid: dx=15mm, dy=15mm

Maximum value of SAR (interpolated) = 12.9 mW/g

**1900 Validation /Z Scan (1x1x16):** Measurement grid: dx=20mm, dy=20mm, dz=20mm

Maximum value of SAR (interpolated) = 2.67 mW/g

**1900 Validation /Zoom Scan (7x7x7)/Cube 0:** Measurement grid: dx=5mm, dy=5mm, dz=5mm

Reference Value = 94.3 V/m; Power Drift = 0.015 dB

Peak SAR (extrapolated) = 19.5 W/kg

**SAR(1 g) = 10.7 mW/g; SAR(10 g) = 5.65 mW/g**

Maximum value of SAR (measured) = 12.0 mW/g

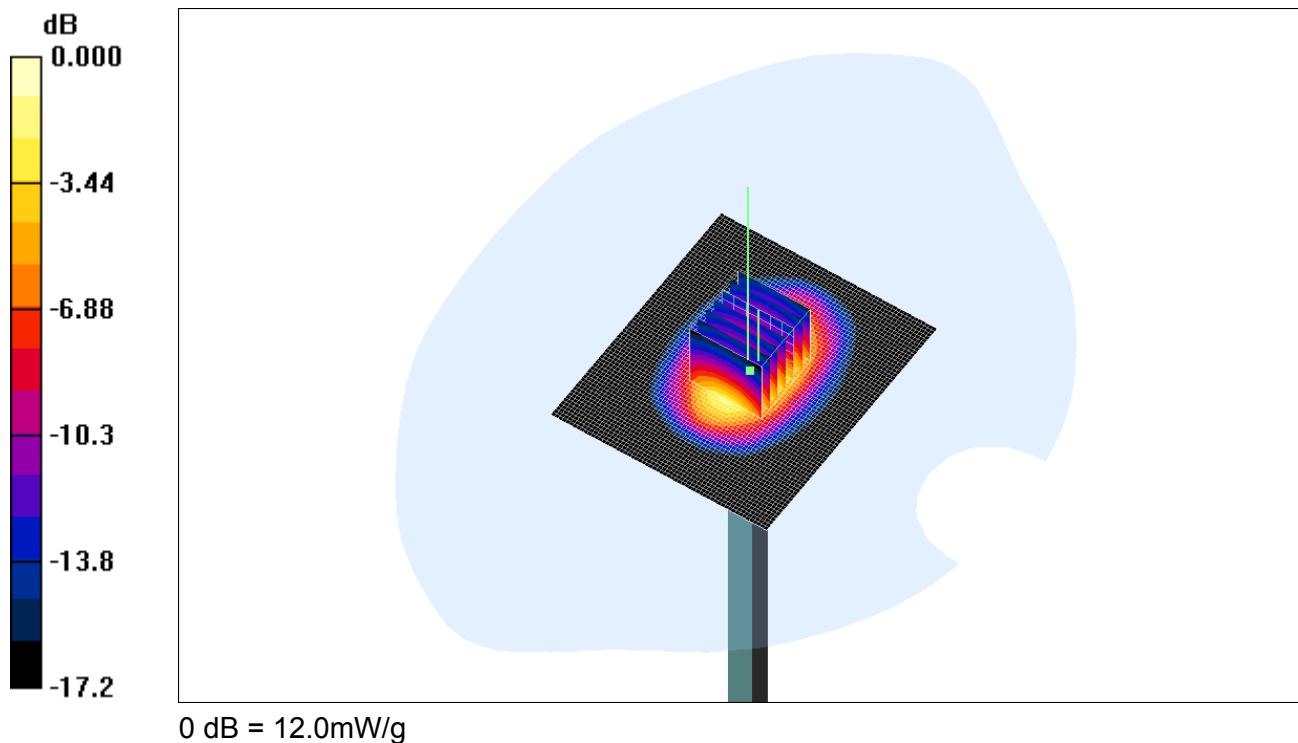

**1900 MHz Body- Verification DATA (D1900V2 – 5d038)**

**- Test Date: 2/25/2014**

**- Measured Liquid Temperature: 22.2 °C, Ambient Temperature: 22.0 °C**

Communication System: CW; Frequency: 1900 MHz; Duty Cycle: 1:1

Medium: MSL1900 Medium parameters used:  $f = 1900 \text{ MHz}$ ;  $\sigma = 1.53 \text{ mho/m}$ ;  $\epsilon_r = 53$ ;  $\rho = 1000 \text{ kg/m}^3$

Phantom section: Flat Section

Measurement Standard: DASY4 (High Precision Assessment)

DASY4 Configuration:

- Probe: EX3DV4 - SN3972; ConvF(7.58, 7.58, 7.58); Calibrated: 2014-01-28
- Sensor-Surface: 4mm (Mechanical Surface Detection) Sensor-Surface: 0mm (Fix Surface)
- Electronics: DAE4 Sn1422; Calibrated: 2014-01-13
- Phantom: SAM Twin Phantom\_1800MHz; Type: SAM; Serial: TP-1433
- Measurement SW: DASY4, V4.7 Build 71; Postprocessing SW: SEMCAD, V1.8 Build 184

**1900 Validation /Area Scan (61x71x1):** Measurement grid:  $dx=15\text{mm}$ ,  $dy=15\text{mm}$

Maximum value of SAR (interpolated) = 13.3 mW/g

**1900 Validation /Z Scan (1x1x16):** Measurement grid:  $dx=20\text{mm}$ ,  $dy=20\text{mm}$ ,  $dz=20\text{mm}$

Maximum value of SAR (interpolated) = 3.89 mW/g

**1900 Validation /Zoom Scan (7x7x7)/Cube 0:** Measurement grid:  $dx=5\text{mm}$ ,  $dy=5\text{mm}$ ,  $dz=5\text{mm}$

Reference Value = 90.6 V/m; Power Drift = 0.005 dB

Peak SAR (extrapolated) = 20.4 W/kg

**SAR(1 g) = 11 mW/g; SAR(10 g) = 5.67 mW/g**

Maximum value of SAR (measured) = 12.4 mW/g

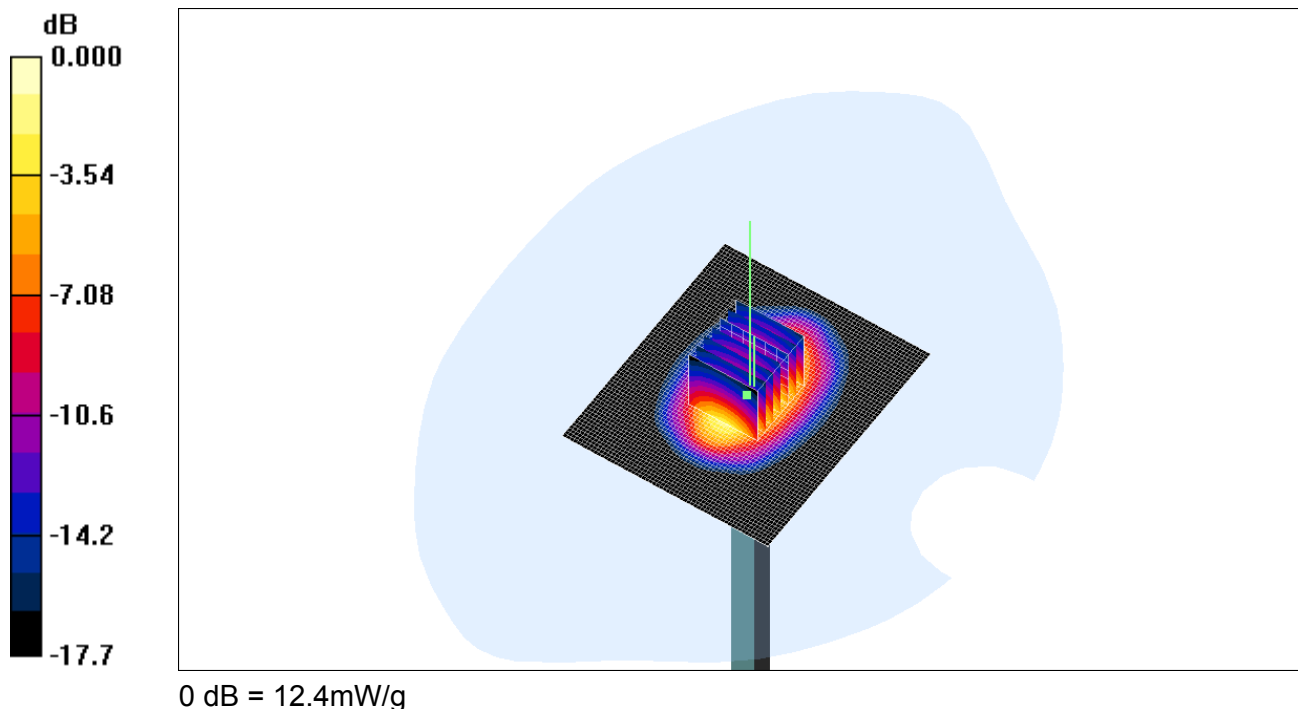



**1900 MHz Body- Verification DATA (D1900V2 – 5d038)**

**- Test Date: 05/13/2014**

**- Measured Liquid Temperature: 22.2 °C, Ambient Temperature: 22.0 °C**

Communication System: CW; Frequency: 1900 MHz; Duty Cycle: 1:1

Medium: MSL1900 Medium parameters used:  $f = 1900 \text{ MHz}$ ;  $\sigma = 1.53 \text{ mho/m}$ ;  $\epsilon_r = 52.9$ ;  $\rho = 1000 \text{ kg/m}^3$

Phantom section: Flat Section

Measurement Standard: DASY4 (High Precision Assessment)

DASY4 Configuration:

- Probe: ES3DV2 - SN3020; ConvF(4.41, 4.41, 4.41); Calibrated: 2014-02-25
- Sensor-Surface: 4mm (Mechanical Surface Detection) Sensor-Surface: 0mm (Fix Surface)
- Electronics: DAE4 Sn1422; Calibrated: 2014-01-13
- Phantom: SAM Twin Phantom\_835MHz; Type: SAM; Serial: TP-1276
- Measurement SW: DASY4, V4.7 Build 71; Postprocessing SW: SEMCAD, V1.8 Build 184

**1900 Validation /Area Scan (61x71x1):** Measurement grid:  $dx=15\text{mm}$ ,  $dy=15\text{mm}$

Maximum value of SAR (interpolated) = 12.4 mW/g

**1900 Validation /Z Scan (1x1x16):** Measurement grid:  $dx=20\text{mm}$ ,  $dy=20\text{mm}$ ,  $dz=20\text{mm}$

Maximum value of SAR (interpolated) = 3.68 mW/g

**1900 Validation /Zoom Scan (7x7x7)/Cube 0:** Measurement grid:  $dx=5\text{mm}$ ,  $dy=5\text{mm}$ ,  $dz=5\text{mm}$

Reference Value = 88.3 V/m; Power Drift = 0.000 dB

Peak SAR (extrapolated) = 17.9 W/kg

**SAR(1 g) = 10.1 mW/g; SAR(10 g) = 5.31 mW/g**

Maximum value of SAR (measured) = 11.5 mW/g

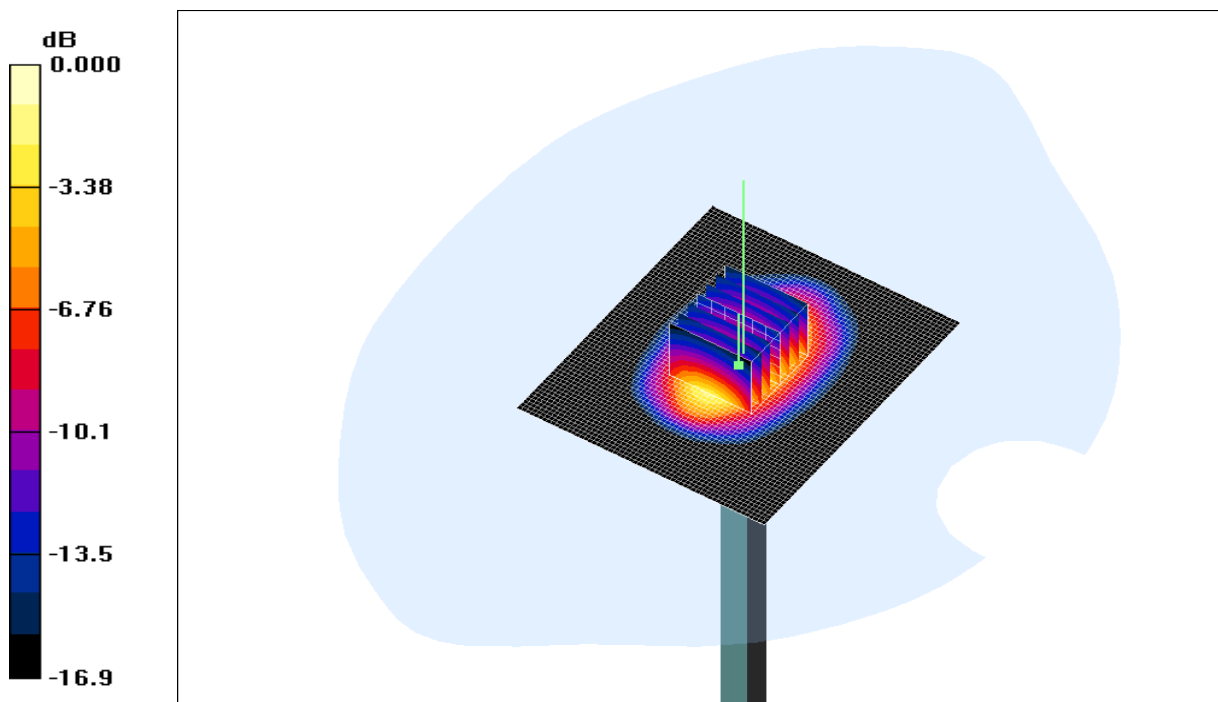

0 dB = 11.5mW/g

**2450 MHz Head- Verification DATA (D245V2 – 746)**

**- Test Date: 2/27/2014**

**- Measured Liquid Temperature: 22.6 °C, Ambient Temperature: 22.0 °C**

Communication System: CW; Frequency: 2450 MHz; Duty Cycle: 1:1

Medium: 2450D Medium parameters used:  $f = 2450$  MHz;  $\sigma = 1.86$  mho/m;  $\epsilon_r = 38.7$ ;  $\rho = 1000$  kg/m<sup>3</sup>

Phantom section: Flat Section

Measurement Standard: DASY4 (High Precision Assessment)

DASY4 Configuration:

- Probe: EX3DV4 - SN3972; ConvF(7.09, 7.09, 7.09); Calibrated: 2014-01-28
- Sensor-Surface: 4mm (Mechanical Surface Detection) Sensor-Surface: 0mm (Fix Surface)
- Electronics: DAE4 Sn1422; Calibrated: 2014-01-13
- Phantom: SAM Twin Phantom\_1800MHz; Type: SAM; Serial: TP-1433
- Measurement SW: DASY4, V4.7 Build 71; Postprocessing SW: SEMCAD, V1.8 Build 184

**2450 Validation Area Scan (61x71x1):** Measurement grid: dx=15mm, dy=15mm

Maximum value of SAR (interpolated) = 16.7 mW/g

**2450 Validation /Z Scan (1x1x16):** Measurement grid: dx=20mm, dy=20mm, dz=20mm

Maximum value of SAR (interpolated) = 2.71 mW/g

**2450 Validation /Zoom Scan (7x7x7)/Cube 0:** Measurement grid: dx=5mm, dy=5mm, dz=5mm

Reference Value = 91.1 V/m; Power Drift = 0.015 dB

Peak SAR (extrapolated) = 29.1 W/kg

**SAR(1 g) = 13.6 mW/g; SAR(10 g) = 6.17 mW/g**

Maximum value of SAR (measured) = 15.3 mW/g

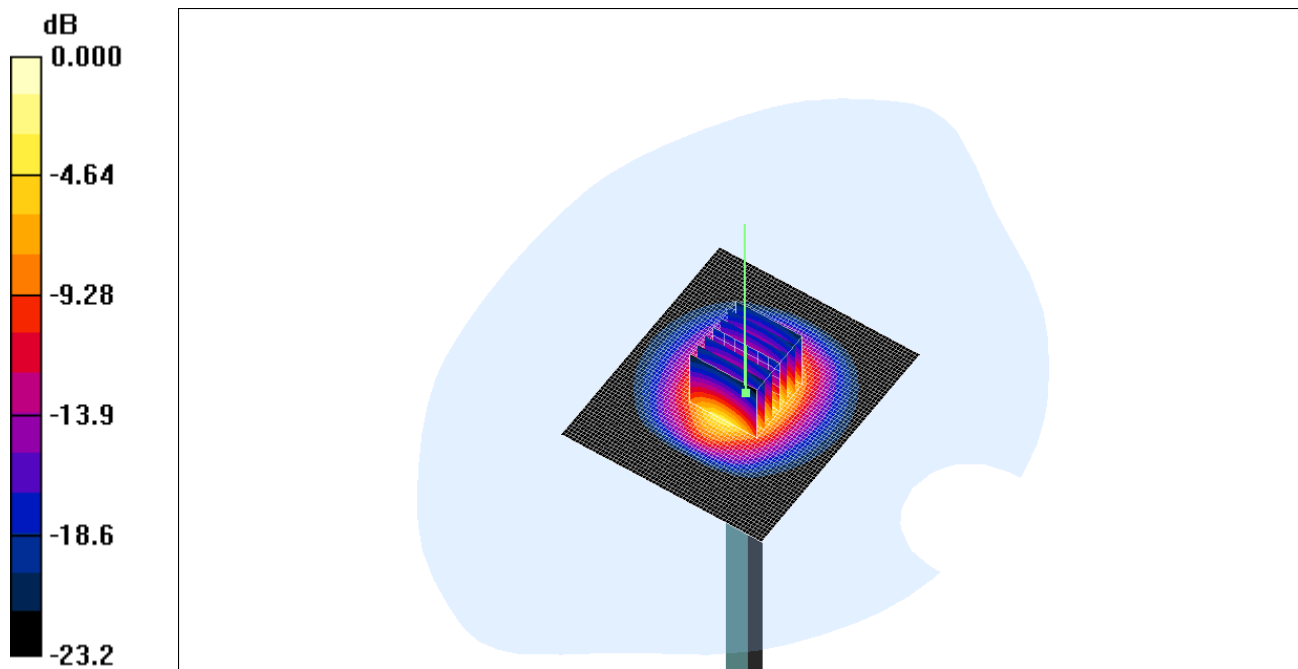

0 dB = 15.3mW/g



**2450 MHz Head- Verification DATA (D245V2 – 746)**

**- Test Date: 05/14/2014**

**- Measured Liquid Temperature: 22.5 °C, Ambient Temperature: 22.0 °C**

Communication System: CW; Frequency: 2450 MHz; Duty Cycle: 1:1

Medium: 2450D Medium parameters used:  $f = 2450$  MHz;  $\sigma = 1.86$  mho/m;  $\epsilon_r = 38.8$ ;  $\rho = 1000$  kg/m<sup>3</sup>

Phantom section: Flat Section

Measurement Standard: DASY4 (High Precision Assessment)

DASY4 Configuration:

- Probe: ES3DV2 - SN3020; ConvF(4.18, 4.18, 4.18); Calibrated: 2014-02-25
- Sensor-Surface: 4mm (Mechanical Surface Detection) Sensor-Surface: 0mm (Fix Surface)
- Electronics: DAE4 Sn1422; Calibrated: 2014-01-13
- Phantom: SAM Twin Phantom\_1800MHz; Type: SAM; Serial: TP-1433
- Measurement SW: DASY4, V4.7 Build 71; Postprocessing SW: SEMCAD, V1.8 Build 184

**2450 Validation 2/Area Scan (61x71x1):** Measurement grid: dx=15mm, dy=15mm

Maximum value of SAR (interpolated) = 16.5 mW/g

**2450 Validation 2/Z Scan (1x1x16):** Measurement grid: dx=20mm, dy=20mm, dz=20mm

Maximum value of SAR (interpolated) = 1.85 mW/g

**2450 Validation 2/Zoom Scan (7x7x7)/Cube 0:** Measurement grid: dx=5mm, dy=5mm, dz=5mm

Reference Value = 91.2 V/m; Power Drift = 0.004 dB

Peak SAR (extrapolated) = 28.4 W/kg

**SAR(1 g) = 13.4 mW/g; SAR(10 g) = 6.17 mW/g**

Maximum value of SAR (measured) = 15.0 mW/g

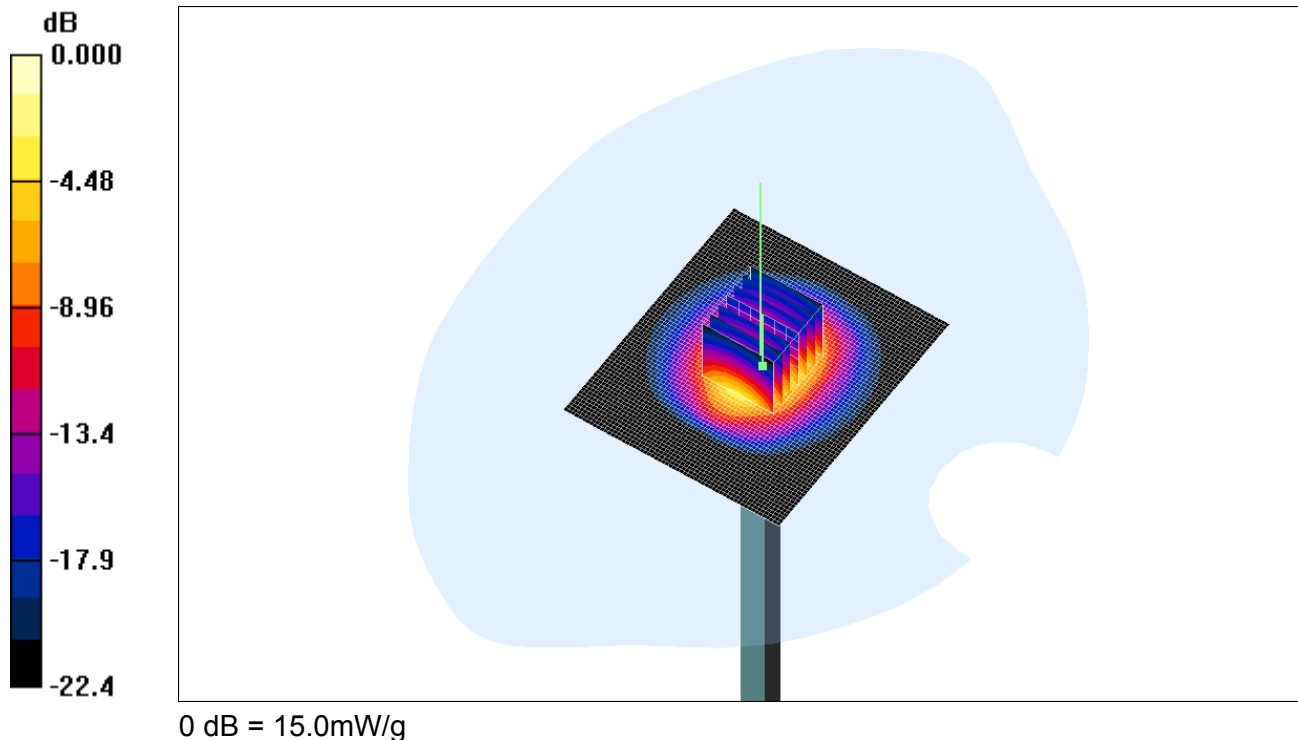

**2450 MHz Body- Verification DATA (D245V2 – 746)**

- Test Date: 02/28/2014

- Measured Liquid Temperature: 23.1 °C, Ambient Temperature: 23.0 °C

Communication System: CW; Frequency: 2450 MHz; Duty Cycle: 1:1

Medium: 2450D Medium parameters used:  $f = 2450$  MHz;  $\sigma = 1.92$  mho/m;  $\epsilon_r = 52.2$ ;  $\rho = 1000$  kg/m<sup>3</sup>

Phantom section: Flat Section

Measurement Standard: DASY4 (High Precision Assessment)

DASY4 Configuration:

- Probe: EX3DV4 - SN3972; ConvF(7.24, 7.24, 7.24); Calibrated: 2014-01-28
- Sensor-Surface: 4mm (Mechanical Surface Detection) Sensor-Surface: 0mm (Fix Surface)
- Electronics: DAE4 Sn1422; Calibrated: 2014-01-13
- Phantom: SAM Twin Phantom\_1800MHz; Type: SAM; Serial: TP-1433
- Measurement SW: DASY4, V4.7 Build 71; Postprocessing SW: SEMCAD, V1.8 Build 184

**2450 Validation /Area Scan (61x71x1):** Measurement grid: dx=15mm, dy=15mm

Maximum value of SAR (interpolated) = 16.5 mW/g

**2450 Validation /Z Scan (1x1x16):** Measurement grid: dx=20mm, dy=20mm, dz=20mm

Maximum value of SAR (interpolated) = 3.46 mW/g

**2450 Validation /Zoom Scan (5x5x7)/Cube 0:** Measurement grid: dx=8mm, dy=8mm, dz=5mm

Reference Value = 89.1 V/m; Power Drift = -0.003 dB

Peak SAR (extrapolated) = 26.5 W/kg

**SAR(1 g) = 13.3 mW/g; SAR(10 g) = 6.19 mW/g**

Maximum value of SAR (measured) = 15.3 mW/g

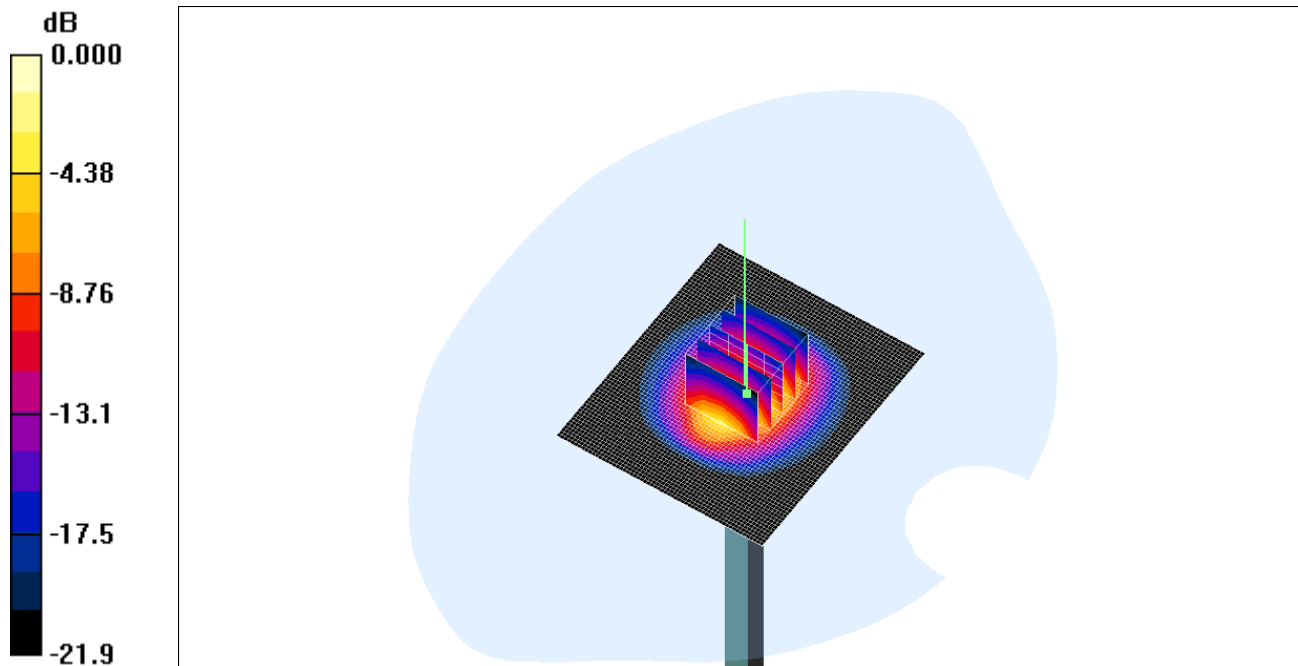

0 dB = 15.3mW/g

**2450 MHz Body- Verification DATA (D245V2 – 746)**

**- Test Date: 05/14/2014**

**- Measured Liquid Temperature: 22.8 °C, Ambient Temperature: 23.0 °C**

Communication System: CW; Frequency: 2450 MHz; Duty Cycle: 1:1

Medium: 2450D Medium parameters used:  $f = 2450 \text{ MHz}$ ;  $\sigma = 1.91 \text{ mho/m}$ ;  $\epsilon_r = 52.2$ ;  $\rho = 1000 \text{ kg/m}^3$

Phantom section: Flat Section

Measurement Standard: DASY4 (High Precision Assessment)

DASY4 Configuration:

- Probe: ES3DV2 - SN3020; ConvF(3.78, 3.78, 3.78); Calibrated: 2014-02-25
- Sensor-Surface: 4mm (Mechanical Surface Detection) Sensor-Surface: 0mm (Fix Surface)
- Electronics: DAE4 Sn1422; Calibrated: 2014-01-13
- Phantom: SAM Twin Phantom\_835MHz; Type: SAM; Serial: TP-1276
- Measurement SW: DASY4, V4.7 Build 71; Postprocessing SW: SEMCAD, V1.8 Build 184

**2450 Validation 2/Area Scan (61x71x1):** Measurement grid:  $dx=15\text{mm}$ ,  $dy=15\text{mm}$

Maximum value of SAR (interpolated) = 16.5 mW/g

**2450 Validation 2/Z Scan (1x1x16):** Measurement grid:  $dx=20\text{mm}$ ,  $dy=20\text{mm}$ ,  $dz=20\text{mm}$

Maximum value of SAR (interpolated) = 3.36 mW/g

**2450 Validation 2/Zoom Scan (5x5x7)/Cube 0:** Measurement grid:  $dx=8\text{mm}$ ,  $dy=8\text{mm}$ ,  $dz=5\text{mm}$

Reference Value = 89.4 V/m; Power Drift = 0.003 dB

Peak SAR (extrapolated) = 27.6 W/kg

**SAR(1 g) = 13.2 mW/g; SAR(10 g) = 6.16 mW/g**

Maximum value of SAR (measured) = 14.8 mW/g

