



We help ideas meet the real world

DELTA Test Report

TEST REPORT issued by an Accredited Testing Laboratory



Radio parameter test of RFID radio in Server lock KS100-640-PA2

Performed for Hanchett Entry Systems, Inc.

REC-E704276_14 Rev. A

Project no.: E704276

Page 1 of 23

26 August 2015

DELTA Development
Technology AB
Finnslätten
Elektronikgatan 47
721 36 Västerås
Sweden

Tel. 021-31 44 80
Fax 021-31 44 81
info@delta-dt.se
www.delta-dt.se

Bankgiro 5534-7728
VAT SE 556556207001

DELTA Development
Technology AB
is a subsidiary company of
DELTA

Title Radio parameter test of RFID radio in Server lock
KS100-640-PA2

Test object Server lock KS100-640-PA2

Report no. REC-E704276_14 Rev. A

Project no. E704276

Test period 23 April 2015 to 12 May 2015

Client Hanchett Entry Systems, Inc.
10027 S. 51st St. Ste. 102
Phoenix, AZ 85044
USA

Contact person Joshua Peabody
Tel: 623-582-4626

Client observer Fredrik Thorsell WSI AB
E-mail: frth@wsi.nu

Manufacturer Hanchett Entry Systems, Inc.

Specifications FCC CFR47 Part 15 subpart C
RSS-Gen, issue 4:2014, RSS-210, issue 8:2010

Results The test object was found to be in compliance with the
specifications, as listed in Section 1

Test personnel Lars Johnsson

Date 26 August 2015

Project Manager



Lars Johnsson
DELTA

Responsible



Ulf Bjerke. Technical manager
DELTA



Table of contents		Page
1.	Summary of tests	4
2.	Test object(s) and auxiliary equipment	5
2.1	Test object(s)	5
2.2	Radio specifications, receiver and transmitter	7
2.3	Auxiliary equipment	8
3.	General test conditions	11
3.1	Test setup during test	11
3.1.1	Description and intended use of test object	11
3.1.2	Modifications of the test object	11
3.1.3	Test sequence	11
4.	Test results	12
4.1	Measurement of radio frequency voltage on mains	12
4.2	Measurement of radiated emission 9 kHz – 30 MHz	15
4.3	Measurement of radiated emission 30 – 1000 MHz	18
5.	National registrations and accreditations	21
5.1	SWEDAC Accreditation	21
5.2	FCC Registrations	21
5.3	IC Registrations	21
6.	List of instruments	22
7.	Revision	23



1. Summary of tests

Tests	Test methods	Results
Measurement of radio frequency voltage on mains (§15.207, RSS Gen 8.8)	ANSI C63.10:2013	Passed
Measurement of radio frequency electromagnetic field 9kHz-30 MHz (§15.209, RSS Gen 6.13)	ANSI C63.10:2013	Passed
Measurement of radio frequency electromagnetic field 30-1000 MHz (§15.209, RSS Gen 6.13)	ANSI C63.10:2013	Passed

This document covers the results from radio parameter tests performed on the 125 kHz RFID radio. The 2.4 GHz Aperio radio which is a part of the complete test object is not included in this report.

Conclusion

The test object(s) mentioned in this report meet(s) the requirements of the standard(s) stated below.

- FCC CFR 47 Part 15C (Intentional radiator at 125 kHz)
- Industry Canada IC Radio Standards Specification, RSS-Gen, issue 4:2014, *General Requirements and Information for the Certification of Radio Apparatus*
- Industry Canada IC Radio Standards Specification, RSS-210, issue 8:2010, *Licence-exempt Radio Apparatus (All Frequency Bands): Category I Equipment*

The test results relate only to the object(s) tested.

2. Test object(s) and auxiliary equipment

2.1 Test object(s)



Photo 2.1.1 Test object.



Test object 2.1.1

Name of test object	Server lock
Model / type	KS100-640-PA2
Part no.	KS100-640-PA2
Serial no.	MAC adress: 06 00 9E 06 00 AE (tests in ch 4.1 and 4.3)
FCC ID	VC3-KKSR100PA
IC ID	7160A-KKSR100622PA
Manufacturer	Hanchett Entry Systems, Inc.
Supply voltage	IEEE 802.3af, 48VDC Power over Ethernet (PoE)
Software version	7.2.30588
Cycle time	-
Received	Date: 23 April 2015 Status: Prototype

2.2 Radio specifications, receiver and transmitter

The RFID radio (125 kHz) of the test object has the following specified RF parameters. The below mentioned information regarding the receiver and the transmitter is declared by the manufacturer.

Type of equipment	:	Low power device (125 kHz)
Operating frequency range	:	125 MHz
Antenna	:	Permanently attached PCB antenna
Power level	:	Fixed
No of channels	:	1
Modulation	:	FSK
Data rate	:	11 kbits
Temperature category	:	-20 to +50 °C.



2.3 Auxiliary equipment



Photo 2.3.1 Auxiliary equipment. PoE injector with adaptor.



Photo 2.3.2 Auxiliary equipment. PoE injector with adaptor.



Auxiliary equipment 2.3.1

Name of auxiliary equipment	Aperio Hub
Model / type	AH30
Serial no.	MAC ID 00.17.7a.01.02.04.44.da
FCC ID	Y88-AH20R01
Manufacturer	ASSA ABLOY
Supply voltage	8-24 VDC
Comment	Auxiliary equipment supplied by the client, who also has the responsibility for its correct function and set up. Used to configure the test object before test.

Auxiliary equipment 2.3.2

Name of auxiliary equipment	Laptop PC
Model / type	HP Compaq 6910p
Part no.	gb949ET#ak8
Serial no.	cnd821lwtf
Manufacturer	HP
Supply voltage	230 VAC
Comment	Auxiliary equipment supplied by the client, who also has the responsibility for its correct function and set up. Used to configure the test object before test.

Auxiliary equipment 2.3.3

Name of auxiliary equipment	TriBee USB
Model / type	200300
Part no.	gb949ET#ak8
Serial no.	cnd821lwtf
FCC ID	YVB-200300
Manufacturer	TriTech
Supply voltage	5 VDC
Comment	Auxiliary equipment supplied by the client, who also has the responsibility for its correct function and set up. Used to configure the test object before test.

Auxiliary equipment 2.3.4

Name of auxiliary equipment	PoE Injector
Model / type	TL-POE150S
Part no.	TL-POE150S
Serial no.	2014B021001732
Manufacturer	TP-Link
Supply voltage	230 VAC to 48 VDC adaptor
Comment	Auxiliary equipment supplied by the client, who also has the responsibility for its correct function and set up. Adaptor: Leader Electronics. Model MU24-1480050-C5



3. General test conditions

3.1 Test setup during test

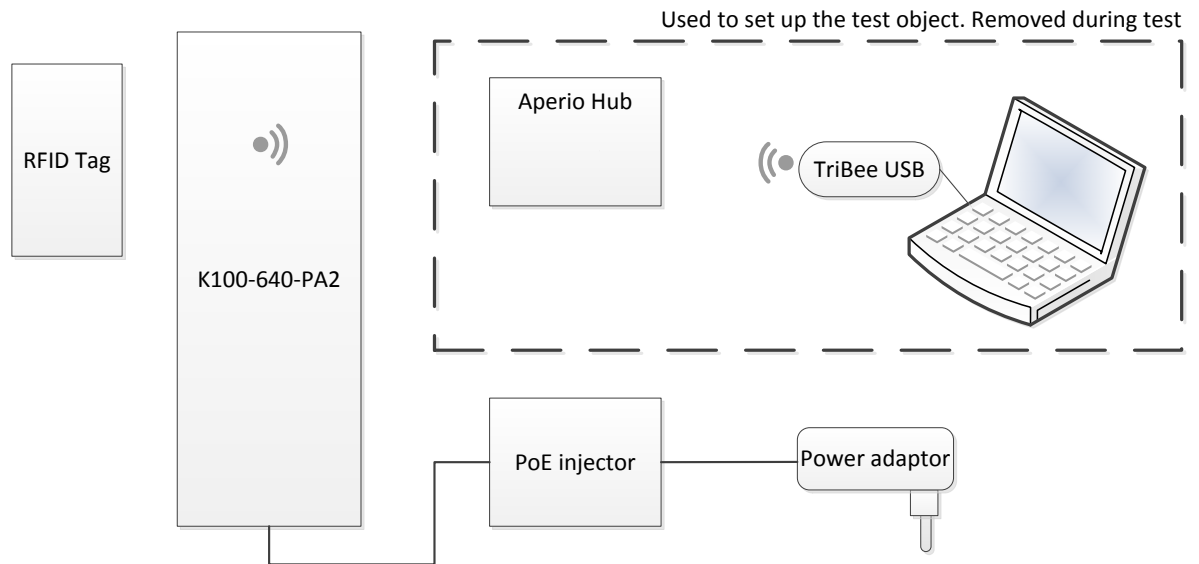

Figure 3.1.1 Block diagram of test object(s) with cables and auxiliary equipment.

3.1.1 Description and intended use of test object

The KS100-640-PA2 is a cabinet lock intended for server cabinets. It is paired to an Aperio Hub (2.4 GHz) to form real-time access control to individual cabinet doors. It uses ID badges (125 kHz) for the access control.

3.1.2 Modifications of the test object

No modifications were incorporated.

3.1.3 Test sequence

The tests described in this test report were performed in the following sequence:

1. Measurement of radio frequency voltage on AC (§15.207, RSS Gen 8.8)
2. Measurement of radio frequency electromagnetic field 30-1000 MHz (§15.209 and RSS Gen 6.13)
3. Measurement of radio frequency electromagnetic field 0.009 - 30 MHz (§15.209, RSS Gen 6.13)

4. Test results

4.1 Measurement of radio frequency voltage on mains

Test object	Server lock	Sheet	CE-1
Type	KS100-640-PA2	Project no.	E704276
Serial no.	MAC adress: 06 00 AE	Date	30 Apr. 2015
Client	ASSA AB	Initials	LAJ
Specification	FCC CFR47 Part 15 subpart C §15.207, RSS Gen 8.8)	Frequency	0.15-30 MHz

Test method	ANSI C63.10:2013	Temperature	21 °C
Characteristics	Artificial mains network: 50 Ω, 50 μH	Humidity	42 % RH
Detector	Peak, quasi peak, and average	Bandwidth	9 kHz
Test equipm.	EMC Hall A Västerås Setup VEA1	Uncertainty	1.8 dB

Line under test	Maximum of Line and Neutral
Test result	The measured voltages were below the limit
Compliant	Yes
Comments	Mains voltage: 115 VAC Tested in the most power consuming mode which is with the 2.4 GHz Aperio transmitter in continuous Tx.

Conducted Emission Test

Test Description: Conducted emission. Complete measurement 150 kHz - 30 MHz
Date: 2015-04-30
EUT Name: KS100-640-PA2
Manufacturer: ASSA AB
Serial Number: MAC address: 06 00 AE
Operating Conditions: 115 VAC, 60 Hz
Test Site: DELTA Development Technology AB
Operator Name: Lars J
Test Specification: FCC Part 15 B Class B
Comment:

Full Spectrum

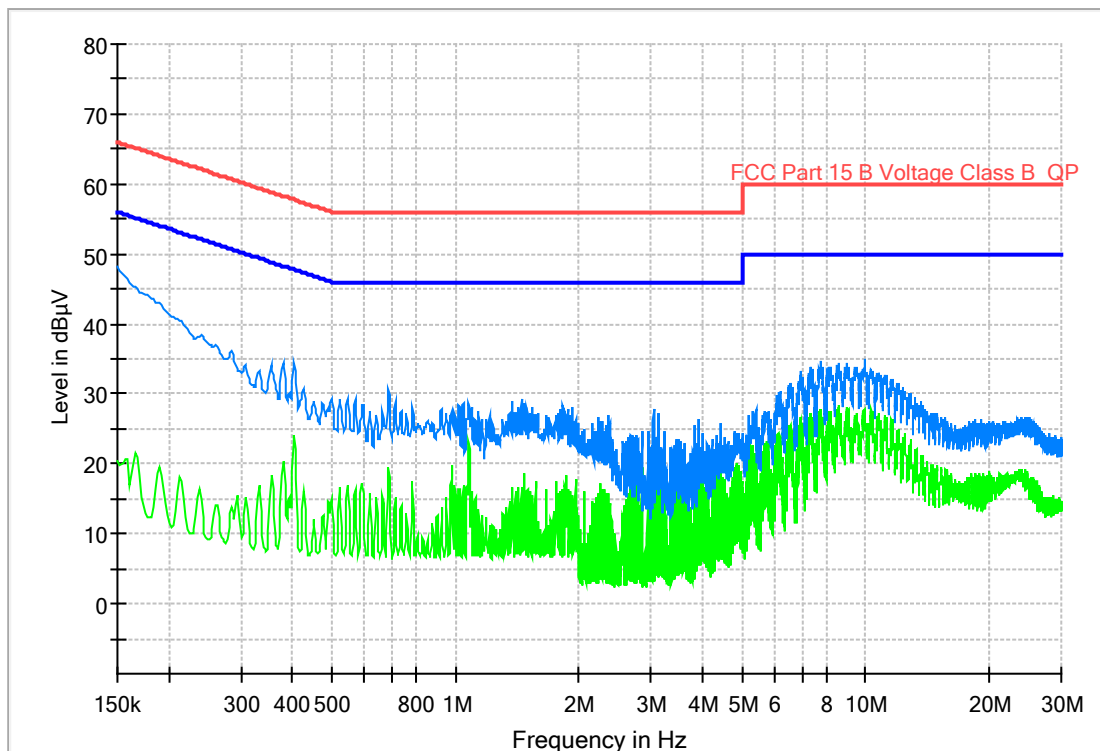

Preview Result 2-AVG
FCC Part 15 B Voltage Class B QP
Final_Result QPK
Preview Result 1-PK+
FCC Part 15 B Voltage Class B AV
Final_Result AVG



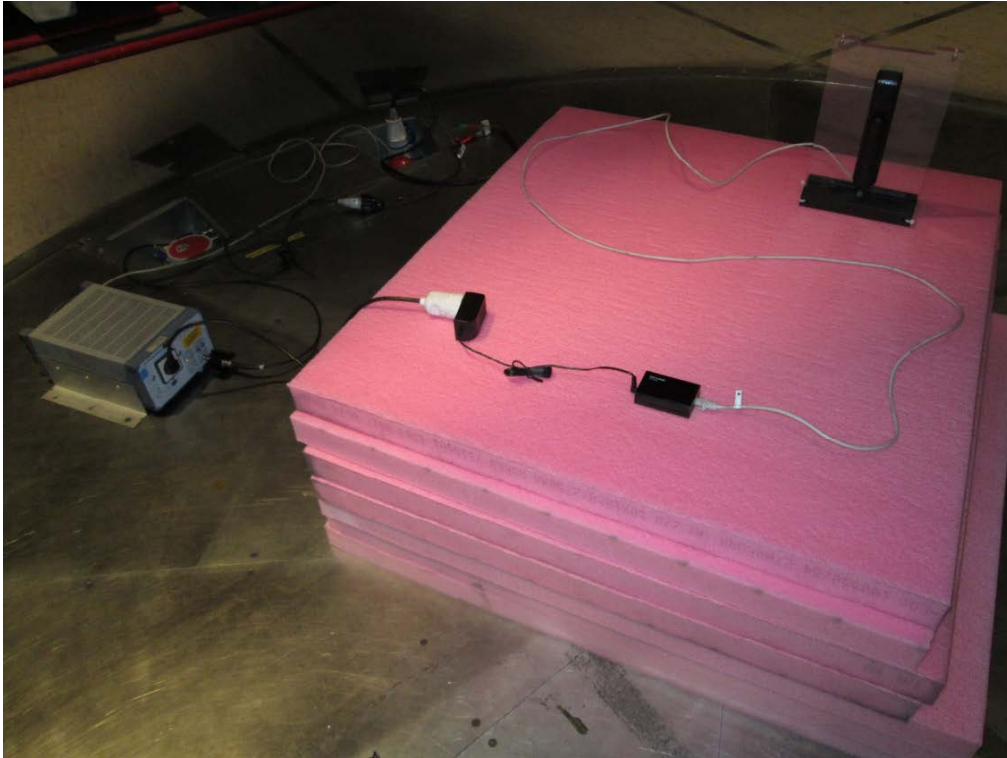

Photo 4.1.1 Test setup regarding measurement of radio frequency voltage on mains.



4.2 Measurement of radiated emission 9 kHz – 30 MHz

Test object	Server lock	Sheet	RE_Spur-1
Type	KS100-640-PA2	Project no.	E704276
Serial no.	MAC adress: 06 00 9E	Date	11 May 2015
Client	ASSA AB	Initials	LAJ
Specification	FCC CFR47 Part 15 subpart C §15.225,15.209 and RSS Gen 6.13	Frequency	9kHz-30MHz

Test method	ANSI C63.10:2013	Temperature	21 °C
Characteristics	Complete search, Antenna distance 10 m	Humidity	41 % RH
Detector	Peak, quasi peak and average	Bandwidth	200 Hz/ 10 kHz
Test equipm.	EMC Hall A Västerås Setup VED1	Uncertainty	3.2 dB

Test result	The measured field strengths are below the limit
Test Port	Enclosure
Test mode	Continuous Tx - normal modulation
Condition	Normal temperature and supply voltage.
Compliant	Yes
Comment	As seen in the graph below the level of the transmitter carrier is below the spurious emission limit.



Radiated Emission Test

Test Description: Radiated emission. Complete measurement 9 kHz - 30 MHz
 Date: 2015-05-11
 EUT Name: KS100-640-PA2
 Manufacturer: Hanchett Entry Systems
 Serial Number:
 Operating Conditions: Continuous Tx
 Test Site: DELTA Development Technology AB
 Operator Name: Lars J
 Test Specification: FCC CFR47 Part 15 subpart C
 Comment: Antenna 3 orthogonal positions

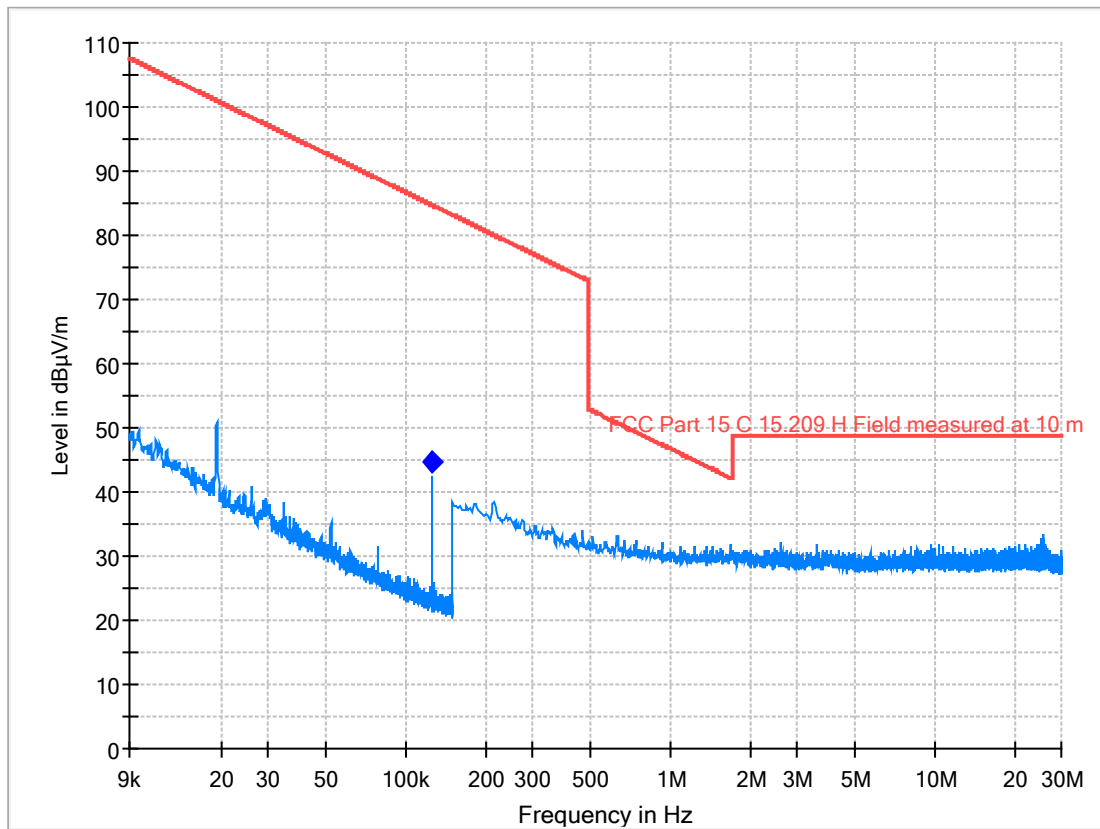

— Preview Result 1-PK+ — FCC Part 15 C 15.209 H Field measured at 10 m ◆ Average

Final Result

Frequency (MHz)	MaxPeak (dBµV/m)	Average (dBµV/m)	Meas. Time (ms)	Bandwidth (kHz)	Pol	Azimuth (deg)	Corr. (dB)
0.124600	46.2	---	500.0	0.200	H	181.0	18.6
0.124600	---	44.6	50.0	0.200	H	181.0	18.6



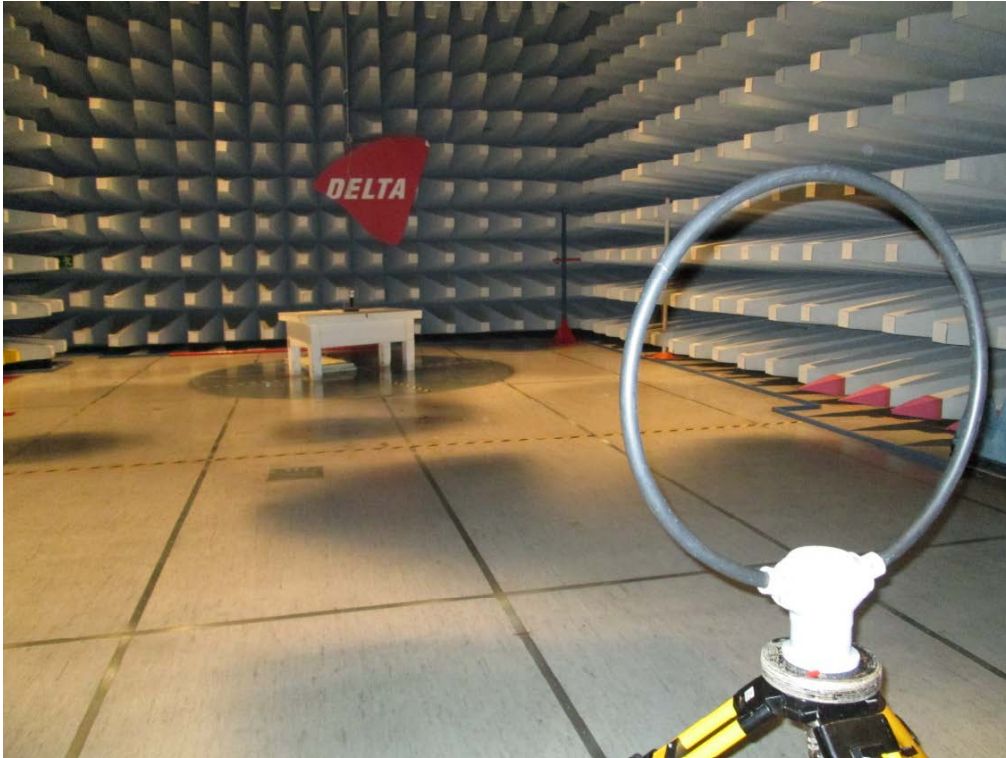

Photo 4.2.1 Test setup regarding measurement of radiated emission 9 kHz – 30 MHz

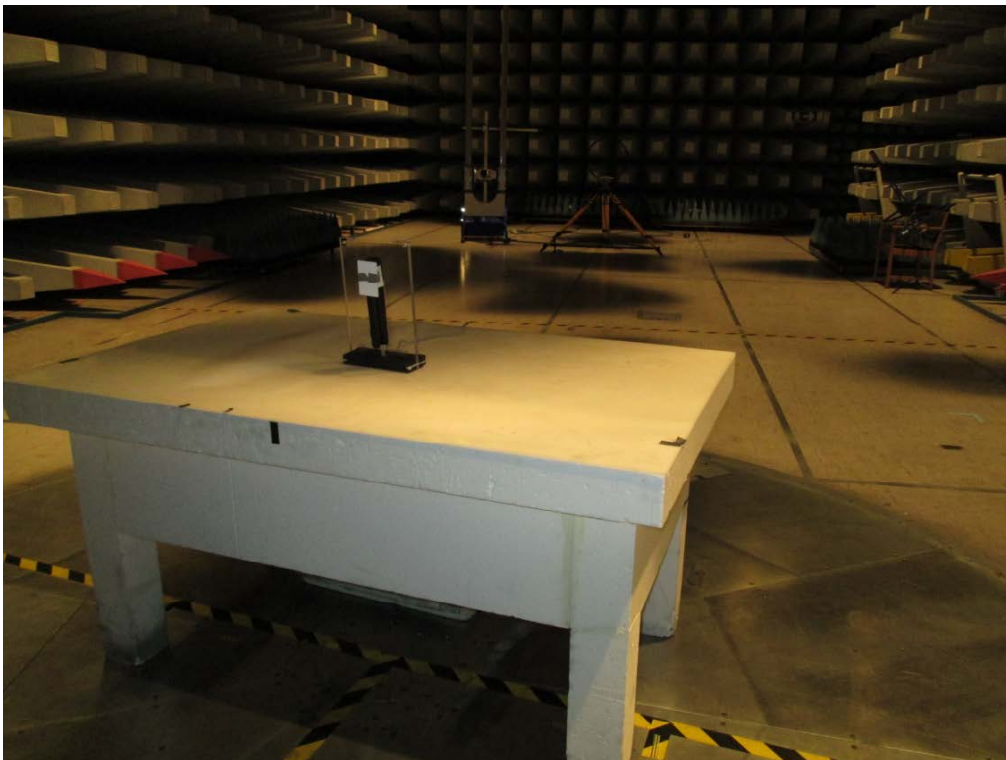

Photo 4.2.2 Test setup regarding measurement of radiated emission 9 kHz – 30 MHz



4.3 Measurement of radiated emission 30 – 1000 MHz

Test object	Server lock	Sheet	RE_Spur-2
Type	KS100-640-PA2	Project no.	E704276
Serial no.	MAC adress: 06 00 AE	Date	23 Apr. 2015
Client	ASSA AB	Initials	LAJ
Specification	FCC CFR47 Part 15 subpart C §15.209, 15.225, 15.249 and RSS Gen 6.13	Frequency	30-1000 MHz

Test method	ANSI C63.10:2013	Temperature	21 °C
Characteristics	Complete search, Antenna distance 3 m	Humidity	41 % RH
Detector	Peak and quasi peak	Bandwidth	120 kHz
Test equipm.	EMC Hall A Västerås Setup VEC1	Uncertainty	5.1 dB

Test result	The measured field strengths are below the limit
Test Port	Enclosure
Test mode	Continuous Tx - Normal modulation
Condition	Normal temperature and supply voltage.
Compliant	Yes



Radiated Emission Test

Test Description: Radiated emission. Complete measurement 30 - 1000 MHz
 Date: 2015-04-25
 EUT Name: K100-622-PA2, KS100-640-PA2
 Manufacturer: ASSA AB
 Serial Number: MAC adress: 06 00 AE (KS100-640-PA2)
 Operating Conditions: Continous 2.4 GHz Tx
 Test Site: DELTA Development Technology AB
 Operator Name: Lars J
 Test Specification: FCC CFR47 part 15. Subpart C. 15.209
 Comment:

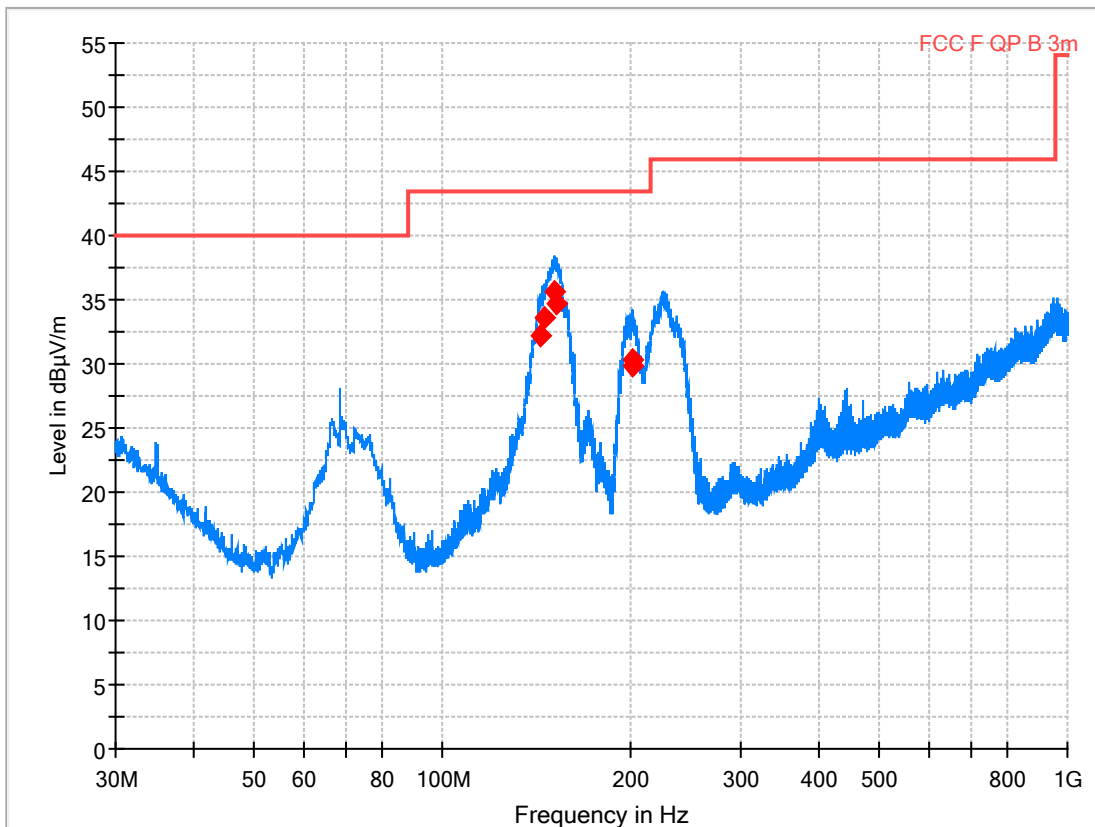

— Preview Result 1-PK+ — FCC F QP B 3m ◆ Final_Result QPK

Final_Result

Frequency (MHz)	QuasiPeak (dBµV/m)	Average (dBµV/m)	Limit (dBµV/m)	Margin (dB)	Meas. Time (ms)	Bandwidth (kHz)	Height (cm)	Pol	Azimuth (deg)	Corr. (dB)
143.880000	32.24	---	43.50	11.26	1000.0	120.000	103.0	V	105.0	-9.1
146.040000	33.60	---	43.50	9.90	1000.0	120.000	103.0	V	112.0	-9.2
151.110000	35.64	---	43.50	7.86	1000.0	120.000	106.0	V	105.0	-9.6
152.010000	34.73	---	43.50	8.77	1000.0	120.000	100.0	V	126.0	-9.6
201.360000	30.32	---	43.50	13.18	1000.0	120.000	107.0	H	49.0	-10.2
201.450000	29.83	---	43.50	13.67	1000.0	120.000	121.0	H	52.0	-10.2



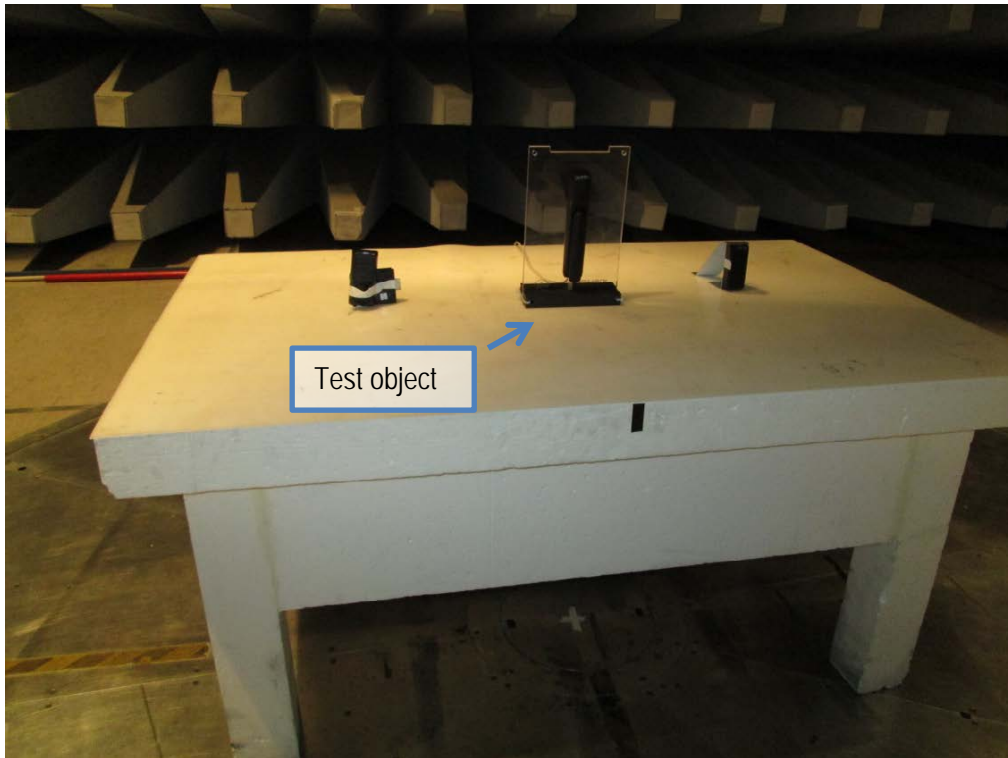

Photo 4.3.1 Test setup regarding measurement of radiated emission 30 – 1000 MHz



Photo 4.3.2 Test setup regarding measurement of radiated emission 30 – 1000 MHz

5. National registrations and accreditations

5.1 SWEDAC Accreditation

Organization: Swedish Board for Accreditation and Conformity Assessment - SWEDAC, see www.swedac.se and www.ilac.org

Registration Number: 1688

SWEDAC is part of ILAC (International Laboratory Accreditation Cooperation) including its MRA (Mutual Recognition Arrangement).

5.2 FCC Registrations

Organization: Federal Communications Commission, USA

Registration Number: 516880

Facilities: EMC chamber A 3 and 10 m

5.3 IC Registrations

Organization: Industry Canada, Certification and Engineering Bureau

Registration Number: 9347A

Facilities: EMC chamber A (9347A-1)



6. List of instruments

Setup VEA1						
Measurement of radio frequency voltage on mains						
<i>Last Cal.</i>	<i>Next Cal.</i>	<i>ID no.</i>	<i>Description</i>	<i>Manufacturer</i>	<i>Type no.</i>	<i>Setup uncertainty</i>
-	-	36070	Software	Rohde & Schwarz	EMC32 ver. 9.15.01	1.8 dB
2014-08	2015-09	36020	Measuring receiver	Rohde & Schwarz	ESU26	
2014-08	2015-09	IE-B919	LISN 2 x 10 A 250 V	Rohde & Schwarz	ESH3-Z5	
2014-04	2015-04	36078	Attenuator 6 dB 10 W	BIRD	10-A-MFB-06	
2014-06	2015-06	36062	Impulse Voltage Limiter	Rohde & Schwarz	ESH3-Z2	

Setup VEC1						
Measurement of radio frequency electromagnetic field						
<i>Last Cal.</i>	<i>Next Cal.</i>	<i>ID no.</i>	<i>Description</i>	<i>Manufacturer</i>	<i>Type no.</i>	<i>Setup uncertainty</i>
-	-	36070	Software	Rohde & Schwarz	EMC32 ver. 9.15.01	5.1 dB 30-1000 MHz (10 m) 6.2 dB 30-1000 MHz (3 m) 4.5 dB 1-6 GHz (3 m)
2014-08	2015-08	IE-B758	Preamplifier	HP	8447F	
2014-08	2015-08	36020	Measuring receiver	Rohde & Schwarz	ESU26	
2013-07	2015-07	IE-B928	Antenna Bilog	Chase	CBL6111A	
2014-08	2015-08	36065	Measuring receiver	Rohde & Schwarz	ESL6	
-	-	36071	Controller	Maturo	NCD	
-	-	36072	Tilt antenna mast	Maturo	TAM 4.0-E	
-	-	-	Turntable	Heinrich Deisel	DT 440	

Setup VED1						
Measurement of radio frequency electromagnetic field (Loop antenna)						
<i>Last Cal.</i>	<i>Next Cal.</i>	<i>ID no.</i>	<i>Description</i>	<i>Manufacturer</i>	<i>Type no.</i>	<i>Setup uncertainty</i>
-	-	36070	Software	Rohde & Schwarz	EMC32 ver. 9.15.01	3.24 dB
2014-08	2015-08	36020	Measuring receiver	Rohde & Schwarz	ESU26	
2013-07	2015-07	35047	Loop antenna	Rohde & Schwarz	HFH2-Z2	

Setup Climate						
Climatic tests						
<i>Last Cal.</i>	<i>Next Cal.</i>	<i>ID no.</i>	<i>Description</i>	<i>Manufacturer</i>	<i>Type no.</i>	<i>Setup uncertainty</i>
-	-	36070	Climatic chamber	Weiss	WK1-1000/40/5	
-	-	IE-B758	Temperature Oven	MEMMERT	UL-40 / 791003	
2015-03	2016-03	IM-A308	Temperature- and hygrometer	Vaisala	HMI31	



7. Revision

Rev. index	Description	Date/ Init
-	New document	18 Aug 2015/ LAJ
A	Standard references updated.	26 Aug 2015/ LAJ