

TEST REPORT

Applicant : Sharp Corporation, Communication Systems Division
Address : 2-13-1, Iida Hachihonmatsu, Higashi-Hiroshima City, Hiroshima,
739-0192, JAPAN

Products : Smart Phone
Model No. : SH-03G
Serial No. : 004401115391753
004401115391597

FCC ID : APYHRO00217

Test Standard : CFR 47 FCC Rules and Regulations Part 27

Test Results : **Passed**

Date of Test : March 16 ~ 26, 2015



Kousei Shibata

Manager

Japan Quality Assurance Organization

KITA-KANSAI Testing Center

SAITO EMC Branch

7-3-10, Saito-asagi, Ibaraki-shi, Osaka 567-0085, Japan

-
- The measurement values stated in Test Report was made with traceable to National Institute of Advanced Industrial Science and Technology (AIST) of Japan and National Institute of Information and Communications Technology (NICT) of Japan.
 - The applicable standard, testing condition and testing method which were used for the tests are based on the request of the applicant.
 - The test results presented in this report relate only to the offered test sample.
 - The contents of this test report cannot be used for the purposes, such as advertisement for consumers.
 - This test report shall not be reproduced except in full without the written approval of JQA.
 - VLAC does not approve, certify or warrant the product by this test report.

TABLE OF CONTENTS

	Page
1 Description of the Equipment Under Test	3
2 Summary of Test Results	4
3 Test Procedure.....	5
4 Test Location	5
5 Recognition of Test Laboratory	5
6 Details of the Equipment Under Test	6
7 Details of the Test Item	10

DEFINITIONS FOR ABBREVIATION AND SYMBOLS USED IN THIS TEST REPORT**EUT** : Equipment Under Test**AE** : Associated Equipment**N/A** : Not Applicable**N/T** : Not Tested**EMC** : Electromagnetic Compatibility**EMI** : Electromagnetic Interference**EMS** : Electromagnetic Susceptibility - indicates that the listed condition, standard or equipment is applicable for this report. - indicates that the listed condition, standard or equipment is not applicable for this report.

1 Description of the Equipment Under Test

1. Manufacturer : Sharp Corporation, Communication Systems Division
2-13-1, Iida Hachihonmatsu, Higashi-Hiroshima City, Hiroshima,
739-0192, JAPAN
2. Products : Smart Phone
3. Model No. : SH-03G
4. Serial No. : 004401115391753
: 004401115391597
5. Product Type : Pre-production
6. Date of Manufacture : January, 2015
7. Power Rating : 4.0VDC (Lithium-ion Battery UBATIA258AFN1 3000mAh)
8. EUT Grounding : None
9. Transmitting Frequency : 706.5 MHz(23755CH) – 713.5MHz(23825CH) (BW: 5MHz)
709.0 MHz(23780CH) – 711.0MHz(23800CH) (BW: 10MHz)
10. Receiving Frequency : 736.5 MHz(5755CH) – 743.5MHz(5825CH) (BW: 5MHz)
739.0 MHz(5780CH) – 741.0MHz(5800CH) (BW: 10MHz)
11. Emission Designations : 4M49G7D (for QPSK,BW: 5 MHz)
4M48D7W (for 16QAM,BW: 5 MHz)
8M93G7D (for QPSK,BW: 10 MHz)
8M94D7W (for 16QAM,BW: 10 MHz)
12. Max. RF Output Power : 0.132W (ERP) (for QPSK,BW: 5 MHz)
0.112W (ERP) (for 16QAM,BW: 5 MHz)
0.132W (ERP) (for QPSK,BW: 10 MHz)
0.112W (ERP) (for 16QAM,BW: 10 MHz)
13. Category : LTE FDD
14. EUT Authorization : Certification
15. Received Date of EUT : March 6, 2015

16. Channel Plan

The carrier spacing is 100 kHz.

The carrier frequency is designated by the absolute frequency channel number (ARFCN).

The carrier frequency is expressed in the equation shown as follows:

$$\text{Transmitting Frequency (in MHz)} = 706.5 + 0.1 \times (n - 23755)$$

where, n : channel number (23755 ≤ n ≤ 23825)

$$\text{Receiving Frequency (in MHz)} = 736.5 + 0.1 \times (n - 5755)$$

where, n : channel number (5755 ≤ n ≤ 5825)

2 Summary of Test Results

Applied Standard : CFR 47 FCC Rules and Regulations Part 27

Subpart H – Competitive Bidding Procedures for the 698-746 MHz Band

The EUT described in clause 1 was tested according to the applied standard shown above.

Details of the test configuration is shown in clause 6.

The conclusion for the test items of which are required by the applied standard is indicated under the test result.

- The test result was **passed** for the test requirements of the applied standard.
- The test result was **failed** for the test requirements of the applied standard.
- The test result was **not judged** the test requirements of the applied standard.

In the approval of test results,

- Determining compliance with the limits in this report was based on the results of the compliance measurement, not taking into account measurement instrumentation uncertainty.
- No deviations were employed from the applied standard.
- No modifications were conducted by JQA to achieve compliance to the limitations.

Reviewed by:

Tested by:



Shigeru Kinoshita
Assistant Manager
JQA KITA-KANSAI Testing Center
SAITO EMC Branch



Shigeru Osawa
Deputy Manager
JQA KITA-KANSAI Testing Center
SAITO EMC Branch

3 Test Procedure

Test Requirements : CFR 47 FCC Rules and Regulations Part 2
§2.1046, §2.1047, §2.1049, §2.1051, §2.1053, §2.1055 and §2.1057

Test Procedure : ANSI C63.4–2003, TIA/EIA–603-C-2004
FCC KDB 971168 D01 Power Meas License Digital Systems v02r02,
released October 17, 2014

4 Test Location

Japan Quality Assurance Organization (JQA)
KITA-KANSAI Testing Center
7-7, Ishimaru, 1-chome, Minoh-shi, Osaka, 562-0027, Japan
SAITO EMC Branch
7-3-10, Saito-asagi, Ibaraki-shi, Osaka 567-0085, Japan

5 Recognition of Test Laboratory

JQA KITA-KANSAI Testing Center SAITO EMC Branch is accredited under ISO/IEC 17025 by following accreditation bodies and the test facility is registered by the following bodies.

VLAC Accreditation No. : VLAC-001-2 (Expiry date : March 30, 2016)
VCCI Registration No. : A-0002 (Expiry date : March 30, 2016)
BSMI Registration No. : SL2-IS-E-6006, SL2-IN-E-6006, SL2-R1/R2-E-6006, SL2-A1-E-6006
(Expiry date : September 14, 2016)
IC Registration No. : 2079E-3, 2079E-4 (Expiry date : July 16, 2017)

Accredited as conformity assessment body for Japan electrical appliances and material law by METI.
(Expiry date : February 22, 2016)

6 Details of the Equipment Under Test

6.1 Operating Condition

1. Bandwidth: 5 MHz/10 MHz
2. Modulation Type: QPSK/16QAM

The tests were carried under worst condition shown as follows:

Test Item	Bandwidth (MHz)	Modulation	RB Size
RF Power Output	5/10	QPSK/16QAM	1
ERP / EIRP RF Power Output	5/10	QPSK/16QAM	1
Occupied Bandwidth	5/10	QPSK/16QAM	Full
Spurious Emissions at Antenna Terminals	5/10	QPSK	1
Band-Edge Emission	5/10	QPSK/16QAM	1/Full
Field Strength of Spurious Radiation	5/10	QPSK	1

The equipment has two antennas(Main/Sub), and changes by the Antenna Switching Diversity (ASDiv) method.

The tests were carried out in the following mode.

- a) Main antenna
- b) Sub antenna

The Radiated Emission test were carried under 3 test configurations shown in clause 6.3.

In all tests, the fully charged battery is used for the EUT.

Other Clock Frequency

19.2MHz, 48MHz, 12MHz, 27.12MHz

The EUT was rotated through three orthogonal axis (X, Y and Z axis) in radiated measurement.

The EUT with temporary antenna port was used in conducted measurement.

RF Output Verification

The tests were conducted at the middle channel. (Main antenna)

Frequency (MHz)	BW (MHz)	Mode	RB Allocation	RB Offset	Target MPR	Conducted Avrage Power (dBm)
710 (23790 ch)	5	QPSK	1	0	0	23.00
			1	13	0	23.06
			1	24	0	22.72
			12	0	1	21.98
			12	7	1	22.02
			12	13	1	21.86
		25	0	1	22.02	
		16QAM	1	0	1	22.09
			1	13	1	22.29
			1	24	1	21.81
			12	0	2	20.77
			12	7	2	21.12
			12	13	2	20.80
		25	0	2	20.87	
	10	QPSK	1	0	0	22.56
			1	25	0	22.68
			1	49	0	22.42
			25	0	1	21.87
			25	13	1	21.82
			25	25	1	21.62
			50	0	1	21.70
		16QAM	1	0	1	21.90
			1	25	1	22.20
			1	49	1	21.57
			25	0	2	20.81
			25	13	2	20.79
			25	25	2	20.62
			50	0	2	20.67

6.2 Test Configuration

The equipment under test (EUT) consists of :

	Item	Manufacturer	Model No.	Serial No.	FCC ID
A	Smart Phone	Sharp	SH-03G	004401115391753 *1) 004401115391597 *2)	APYHRO00217
B	AC Adapter	Fujitsu Corporation	05	XFA	N/A
C	Stereo Handsfree	Sharp	SHLDL1	--	N/A
D	DTV Antenna	Sharp	SH01	--	N/A

*1) Used for Field Strength of Spurious Emission

*2) Used for Antenna Conducted Emission and Frequency Stability

The auxiliary equipment used for testing :

None

Type of Cable:

No.	Description	Identification (Manu. etc.)	Connector Shielded	Cable Shielded	Ferrite Core	Length (m)
1	USB conversion cable	--	--	NO	YES	1.2
2	Handsfree Cable	--	--	NO	NO	1.5
3	DTV Antenna Cable	--	--	NO	NO	0.3

6.3 Test Arrangement (Drawings)

a) Single Unit

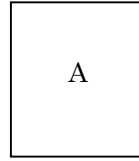

b) AC Adapter used

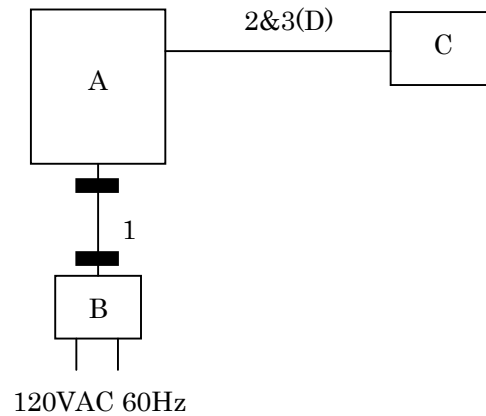

c) Earphone used

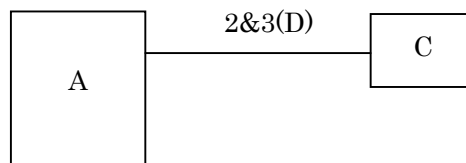
 : Ferrite Core

7 Details of the Test Item

7.0 Summary of the Test Results

Test Item	FCC Specification	Reference of the Test Report	Results	Remarks
RF Power Output	Section 27.50(c)(10)	Section 7.1	Passed	-
ERP / EIRP RF Power Output	Section 27.50(c)(10)	Section 7.2	Passed	-
Modulation Characteristics	-	-	-	-
Occupied Bandwidth	Section 27.53(g)	Section 7.4	Passed	-
Spurious Emissions at Antenna Terminals	Section 27.53(g)	Section 7.5	Passed	-
Band-Edge Emission	Section 27.53(g)	Section 7.6	Passed	-
Field Strength of Spurious Radiation	Section 27.53(g)	Section 7.7	Passed	-
Frequency Stability	Section 27.54	Section 7.8	Passed	-

7.1 RF Power Output (§2.1046)

For the requirements, - Applicable - Tested. - Not tested by applicant request.]
 - Not Applicable

For the limits, - Passed - Failed - Not judged

7.1.1 Worst Point and Measurement Uncertainty

Transmitter Power of BW:5 MHz(QPSK) is 202.3 mW at 710.000 MHz
 Transmitter Power of BW:5 MHz(16QAM) is 169.4 mW at 710.000 MHz
 Transmitter Power of BW:10 MHz(QPSK) is 188.4 mW at 709.000 MHz
 Transmitter Power of BW:10 MHz(16QAM) is 166.0 mW at 710.000 MHz

Uncertainty of Measurement Results at Amplitude +/-0.9 dB(2σ)

Remarks : _____

7.1.2 Test Site and Instruments

7.1.2.1 Test Site

KITA-KANSAI Testing Center

Test site : SAITO

<input type="checkbox"/> - Anechoic chamber (A1)	<input type="checkbox"/> - Measurement room (M1)
<input type="checkbox"/> - Measurement room (M2)	<input type="checkbox"/> - Measurement room (M3)
<input type="checkbox"/> - Shielded room (S1)	<input type="checkbox"/> - Shielded room (S2)
<input type="checkbox"/> - Shielded room (S3)	<input checked="" type="checkbox"/> - Shielded room (S4)

7.1.2.2 Test Instruments

Type	Model	Manufacturer	ID No.	Last Cal.	Interval
Spectrum Analyzer	E4446A	Agilent	A-39	2014/9	1 Year
Power Meter	N1911A	Agilent	B-63	2014/7	1 Year
Power Sensor	N1921A	Agilent	B-64	2014/7	1 Year
Attenuator	43KC-20	Anritsu	D-41	2014/6	1 Year
RF Cable	SUCOFLEX102	SUHNER	C-52	2014/8	1 Year

7.1.3 Test Method and Test Setup (Diagrammatic illustration)

The Conducted RF Power Output and CCDF were measured with a power meter ,a spectrum analyzer, one attenuator and a short, low loss cable.

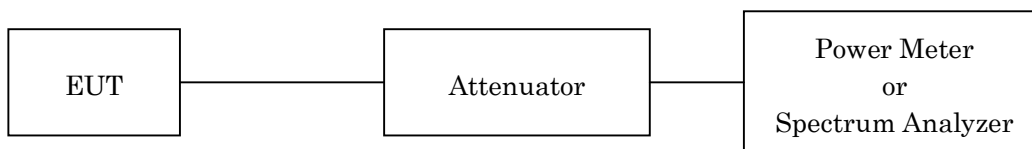

7.1.4 Test Data

a) Main Antenna

1) BW 5MHz(1RB)

Mode: QPSK

(LTE 5MHz)QPSK

Test Date: March 16, 2015

Temp.: 22 °C, Humi: 45 %

CH	Transmitting Frequency	Correction Factor	Meter Reading (Average)	Results (Average)	
	[MHz]			[dB]	[dBm]
23755	706.500	20.20	2.48	22.68	185.4
23790	710.000	20.20	2.86	23.06	202.3
23825	713.500	20.21	2.30	22.51	178.2

Calculated result at 710.000 MHz, as the maximum level point shown on underline:

Correction Factor	=	20.20	dB
+) Meter Reading	=	2.86	dBm
Result	=	23.06	dBm = 202.3 mW

NOTE : The correction factor shows the attenuation pad loss including the short, low loss cable or adapter.

Mode: 16QAM

(LTE 5MHz)16QAM

Test Date: March 16, 2015

Temp.: 22 °C, Humi: 45 %

CH	Transmitting Frequency	Correction Factor	Meter Reading (Average)	Results (Average)	
	[MHz]			[dB]	[dBm]
23755	706.500	20.20	1.70	21.90	154.9
23790	710.000	20.20	2.09	22.29	169.4
23825	713.500	20.21	1.50	21.71	148.3

Calculated result at 710.000 MHz, as the maximum level point shown on underline:

Correction Factor	=	20.20	dB
+) Meter Reading	=	2.09	dBm
Result	=	22.29	dBm = 169.4 mW

NOTE : The correction factor shows the attenuation pad loss including the short, low loss cable or adapter.

2) BW 10MHz(1RB)

Mode: QPSK

(LTE 10MHz)QPSK

Test Date: March 16, 2015

Temp.: 22 °C, Humi: 45 %

CH	Transmitting Frequency	Correction Factor	Meter Reading (Average)	Results (Average)	
	[MHz]			[dB]	[dBm]
23780	709.000	20.20	2.55	22.75	188.4
23790	710.000	20.20	2.48	22.68	185.4
23800	711.000	20.21	2.34	22.55	179.9

Calculated result at 709.000 MHz, as the maximum level point shown on underline:

Correction Factor	=	20.20	dB
+) Meter Reading	=	2.55	dBm
Result	=	22.75	dBm = 188.4 mW

NOTE : The correction factor shows the attenuation pad loss including the short, low loss cable or adapter.

Mode: 16QAM

(LTE 10MHz)16QAM

Test Date: March 16, 2015

Temp.: 22 °C, Humi: 45 %

CH	Transmitting Frequency	Correction Factor	Meter Reading (Average)	Results (Average)	
	[MHz]			[dB]	[dBm]
23780	709.000	20.20	1.58	21.78	150.7
23790	710.000	20.20	2.00	22.20	166.0
23800	711.000	20.21	1.46	21.67	146.9

Calculated result at 710.000 MHz, as the maximum level point shown on underline:

Correction Factor	=	20.20	dB
+) Meter Reading	=	2.00	dBm
Result	=	22.20	dBm = 166.0 mW

NOTE : The correction factor shows the attenuation pad loss including the short, low loss cable or adapter.

3) CCDF

Channel	Frequency (MHz)	BW (MHz)	Peak to Average Factor(CCDF 0.1%) [dB]	
			QPSK	16QAM
23790	710.00	5	5.03	6.01
23790	710.00	10	5.05	6.17

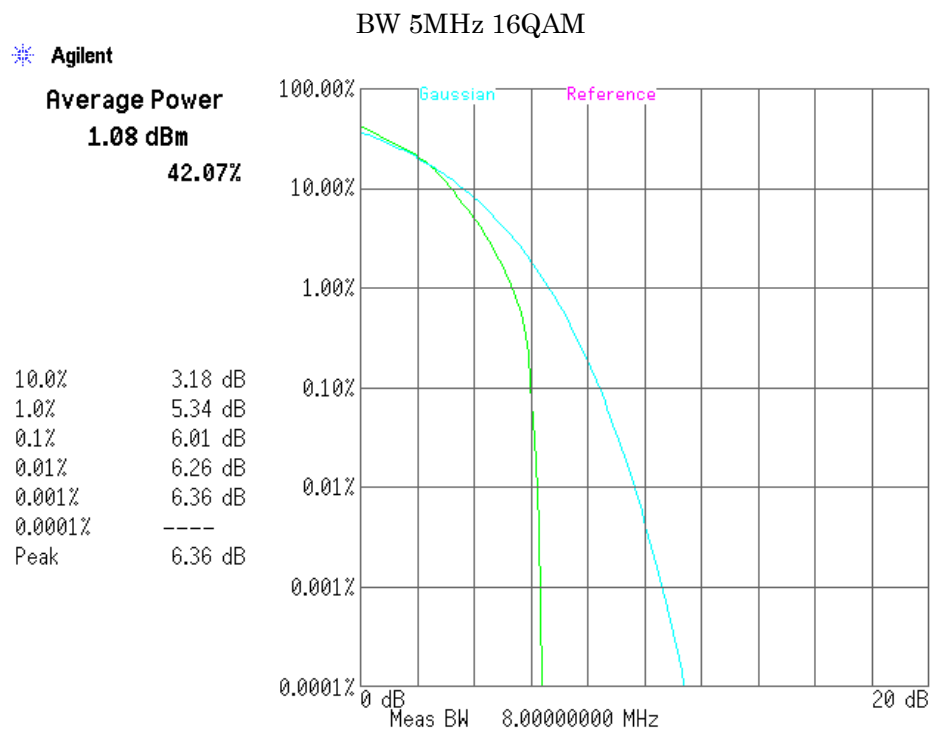
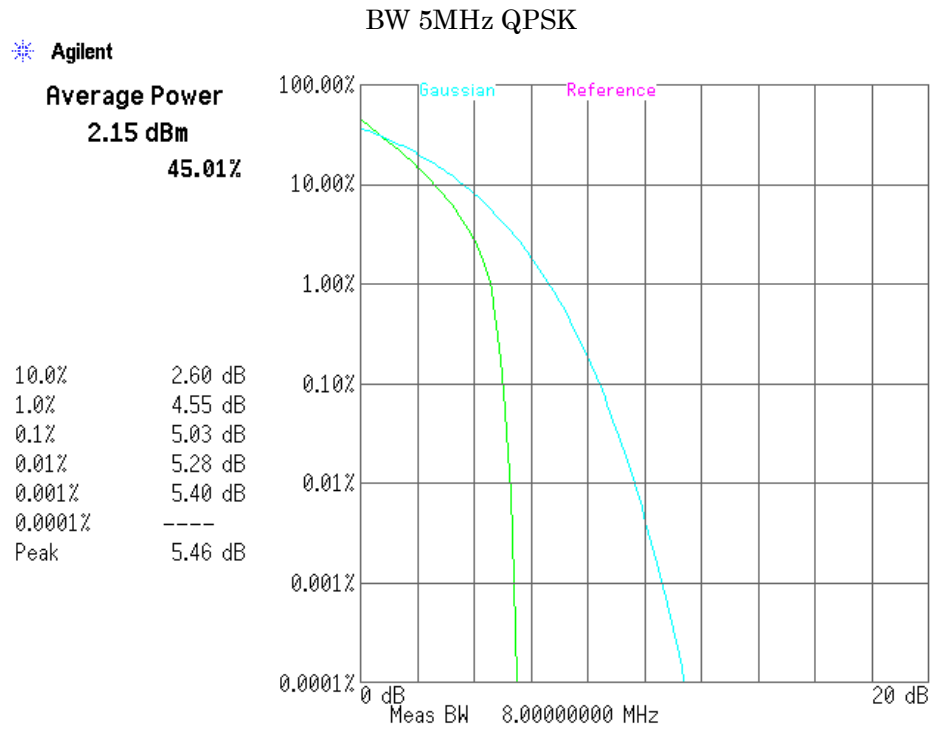

BW 10MHz QPSK

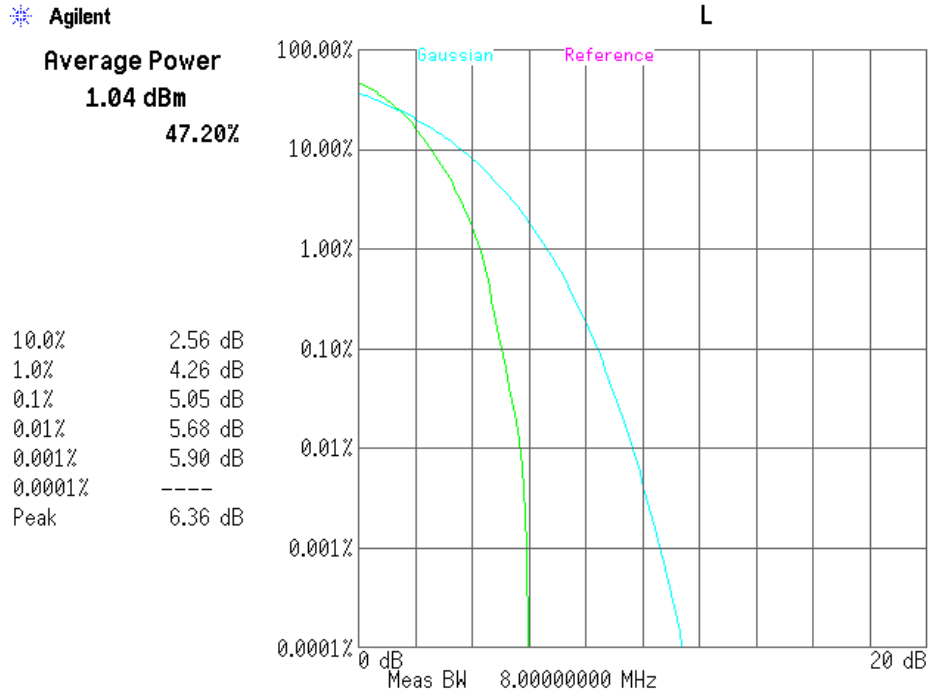

BW 10MHz 16QAM

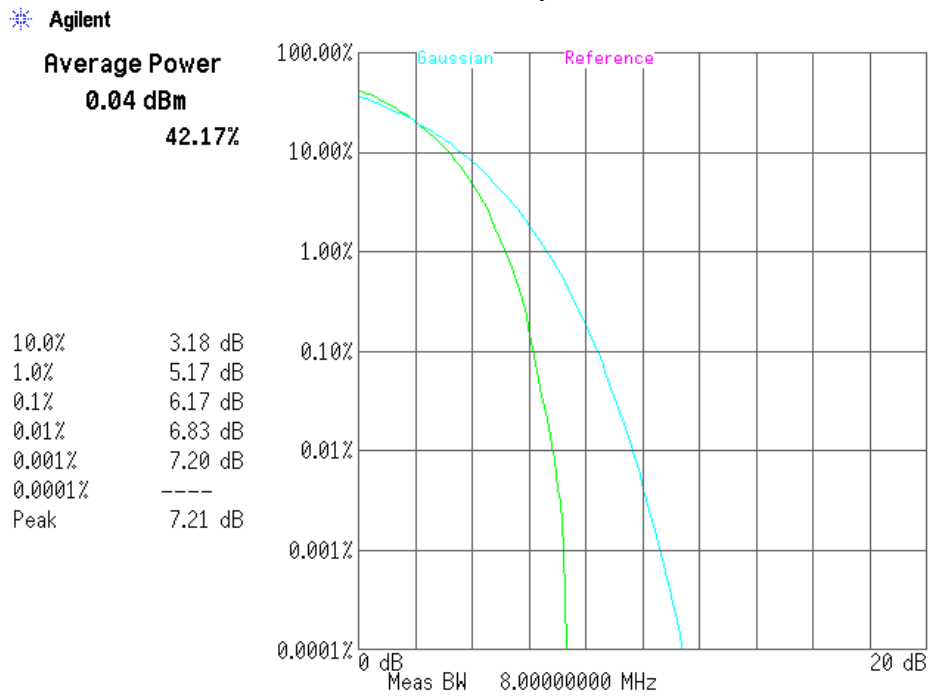

b) Sub Antenna

1) BW 5MHz(1RB)

Mode: QPSK

(LTE 5MHz)QPSK

Test Date: March 16, 2015

Temp.: 22 °C, Humi: 45 %

Transmitting Frequency CH	[MHz]	Correction Factor [dB]	Meter Reading (Average) [dBm]	Results (Average)	
				[dBm]	[mW]
23755	706.500	20.20	2.47	22.67	184.9
23790	710.000	20.20	2.74	22.94	196.8
23825	713.500	20.21	2.18	22.39	173.4

Calculated result at 710.000 MHz, as the maximum level point shown on underline:

Correction Factor	=	20.20	dB
+) Meter Reading	=	2.74	dBm
Result	=	22.94	dBm = 196.8 mW

NOTE : The correction factor shows the attenuation pad loss including the short, low loss cable or adapter.

Mode: 16QAM

(LTE 5MHz)16QAM

Test Date: March 16, 2015

Temp.: 22 °C, Humi: 45 %

Transmitting Frequency CH	[MHz]	Correction Factor [dB]	Meter Reading (Average) [dBm]	Results (Average)	
				[dBm]	[mW]
23755	706.500	20.20	1.65	21.85	153.1
23790	710.000	20.20	1.96	22.16	164.4
23825	713.500	20.21	1.36	21.57	143.5

Calculated result at 710.000 MHz, as the maximum level point shown on underline:

Correction Factor	=	20.20	dB
+) Meter Reading	=	1.96	dBm
Result	=	22.16	dBm = 164.4 mW

NOTE : The correction factor shows the attenuation pad loss including the short, low loss cable or adapter.

2) BW 10MHz(1RB)

Mode: QPSK

(LTE 10MHz)QPSK

Test Date: March 16, 2015

Temp.: 22 °C, Humi: 45 %

CH	Transmitting Frequency	Correction Factor	Meter Reading (Average)	Results (Average)	
	[MHz]			[dB]	[dBm]
23780	709.000	20.20	2.37	22.57	180.7
23790	710.000	20.20	2.34	22.54	179.5
23800	711.000	20.21	2.13	22.34	171.4

Calculated result at 709.000 MHz, as the maximum level point shown on underline:

Correction Factor	=	20.20	dB
+) Meter Reading	=	2.37	dBm
Result	=	22.57	dBm = 180.7 mW

NOTE : The correction factor shows the attenuation pad loss including the short, low loss cable or adapter.

Mode: 16QAM

(LTE 10MHz)16QAM

Test Date: March 16, 2015

Temp.: 22 °C, Humi: 45 %

CH	Transmitting Frequency	Correction Factor	Meter Reading (Average)	Results (Average)	
	[MHz]			[dB]	[dBm]
23780	709.000	20.20	1.62	21.82	152.1
23790	710.000	20.20	1.57	21.77	150.3
23800	711.000	20.21	1.41	21.62	145.2

Calculated result at 709.000 MHz, as the maximum level point shown on underline:

Correction Factor	=	20.20	dB
+) Meter Reading	=	1.62	dBm
Result	=	21.82	dBm = 152.1 mW

NOTE : The correction factor shows the attenuation pad loss including the short, low loss cable or adapter.

3) CCDF

Channel	Frequency (MHz)	BW (MHz)	Peak to Average Factor(CCDF 0.1%) [dB]	
			QPSK	16QAM
23790	710.00	5	5.11	6.02
23790	710.00	10	5.03	6.18

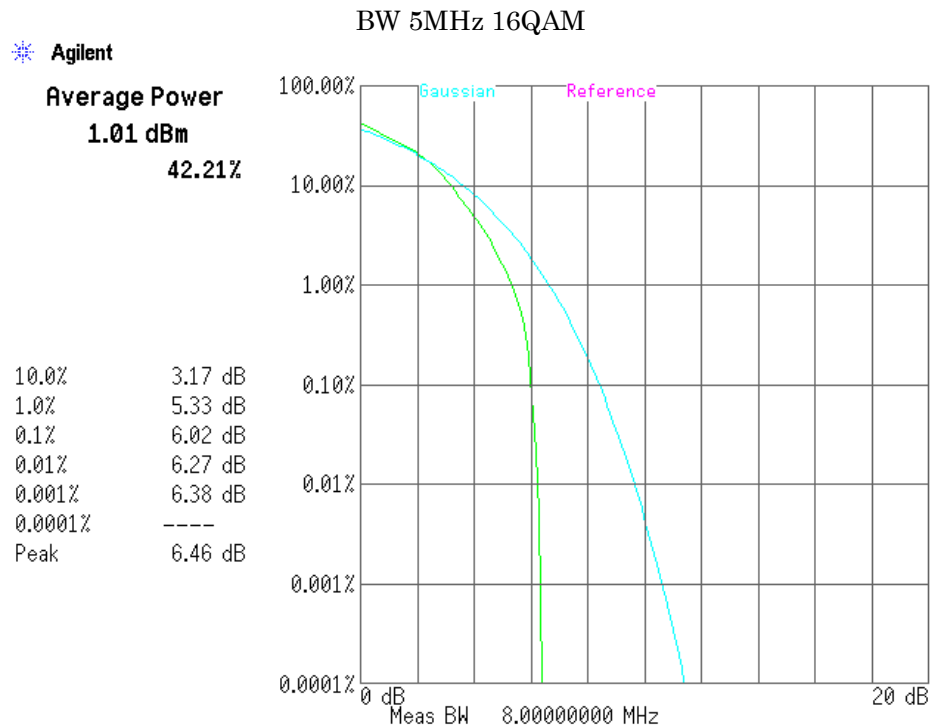
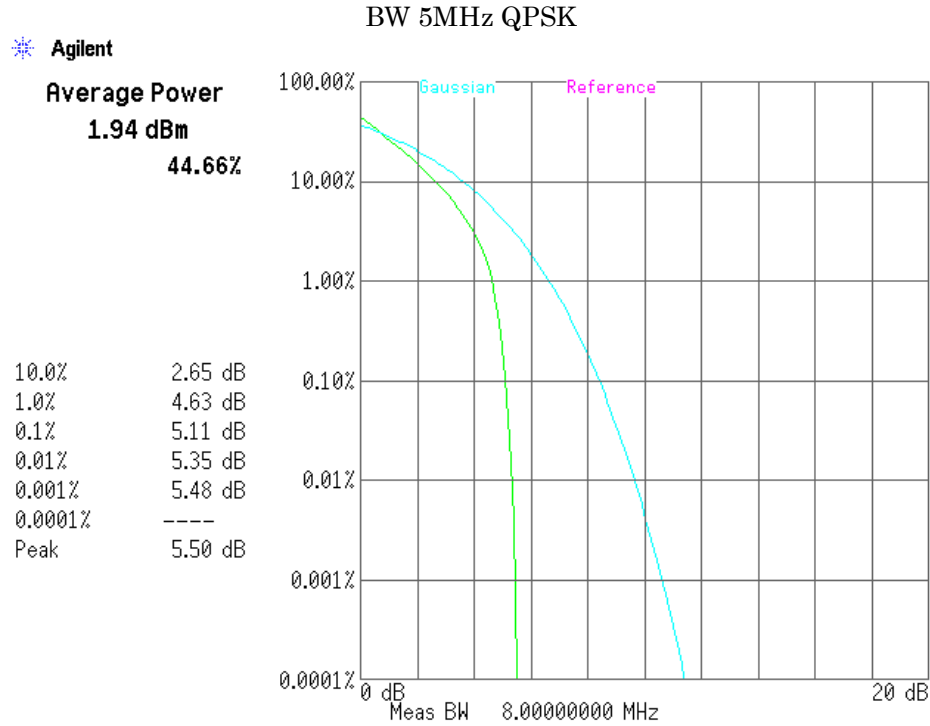

BW 10MHz QPSK

* Agilent

Average Power

1.09 dBm

47.57%

10.0%	2.53 dB
1.0%	4.25 dB
0.1%	5.03 dB
0.01%	5.60 dB
0.001%	5.85 dB
0.0001%	----
Peak	6.27 dB

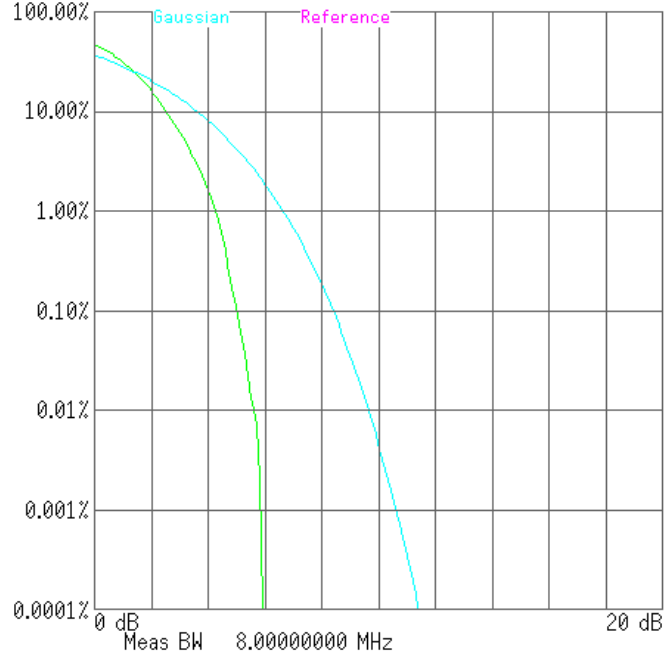

BW 10MHz 16QAM

* Agilent

Average Power

0.06 dBm

41.97%

10.0%	3.19 dB
1.0%	5.16 dB
0.1%	6.18 dB
0.01%	6.78 dB
0.001%	7.17 dB
0.0001%	----
Peak	7.17 dB

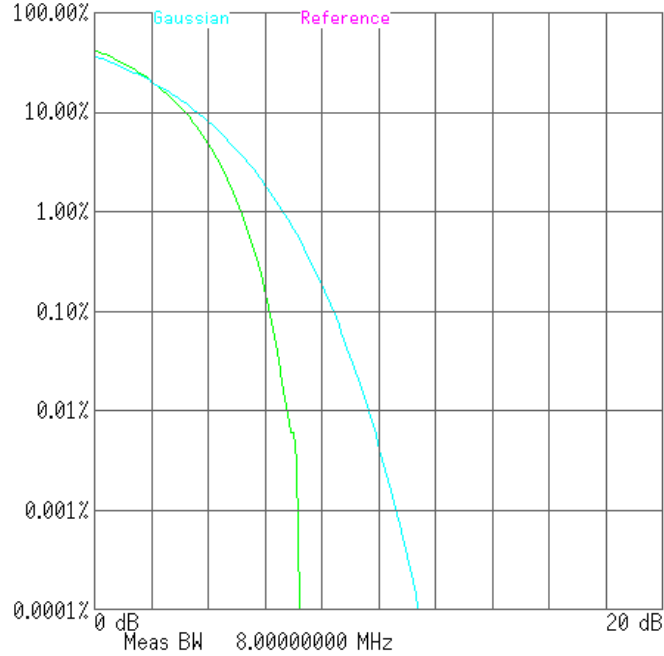

7.2 ERP / EIRP RF Power Output

For the requirements, - Applicable - Tested. - Not tested by applicant request.]
 - Not Applicable

For the limits, - Passed - Failed - Not judged

7.2.1 Worst Point and Measurement Uncertainty

Min. Limit Margin 13.6 dB at 709.0/710.0 MHz

Uncertainty of Measurement Results +/-1.6 dB(2σ)

Remarks : The maximum ERP is 0.132 W at 710.0MHz(BW 5MHz, QPSK) and 709.0/710.0MHz(BW 10MHz, QPSK).

7.2.2 Test Site and Instruments

7.2.2.1 Test Site

KITA-KANSAI Testing Center SAITO EMC Branch

- Anechoic chamber A1 - Anechoic chamber A2

7.2.2.2 Test Instruments

Type	Model	Manufacturer	ID No.	Last Cal.	Interval
Test Receiver	ESU26	Rohde & Schwarz	A-6	2014/5	1 Year
Signal Generator	E8257D	Agilent	B-39	2014/8	1 Year
Power Meter	N1911A	Agilent	B-63	2014/7	1 Year
Power Sensor	N1921A	Agilent	B-64	2014/7	1 Year
Attenuator(TX)	2-10	Weinschel	D-79	2014/11	1 Year
Log-periodic Antenna	UHALP9108-A1	Schwarzbeck	C-31	2014/5	1 Year
Dipole Antenna(TX)	KBA-611	Kyoritsu	C-20	2014/5	1 Year

7.2.3 Test Method and Test Setup (Diagrammatic illustration)

Step 1:

In order to obtain the maximum emission, the EUT was placed at the height 1.5 m on the non-conducted support and was varying at three orthogonal axes, at the distance 3 m from the receiving antenna and rotated around 360 degrees.

The receiving antenna height was varied from 1 m to 4 m.

The EUT on the table was placed to be maximum emission against at the receiving antenna polarized (vertical and horizontal).

Then the meter reading of the spectrum analyzer at the maximum emission was A dB(μ V).

Step 2:

The EUT was replaced to substitution antenna at the same polarized under the same condition as step 1.

The RF power was fed to the transmitting antenna through the RF amplifier from the signal generator.

In order to obtain the maximum emission level, the height of the receiving antenna was varied from 1 m to 4 m.

The level of maximum emission was A dB(μ V), same as the recorded level in the step 1.

Then the RF power into the substitution horn antenna was P (dBm).

The ERP/EIRP output power was calculated in the following equation.

$$\text{ERP (dBm)} = \text{P (dBm)} - \text{Balun loss of the tuned dipole antenna (dB)} + \text{Cable loss (dB)}$$

$$\text{EIRP (dBm)} = \text{P (dBm)} + \text{Gh (dBi)}$$

where, Gh (dBi) : Gain of the substitution horn antenna.

– Side View –

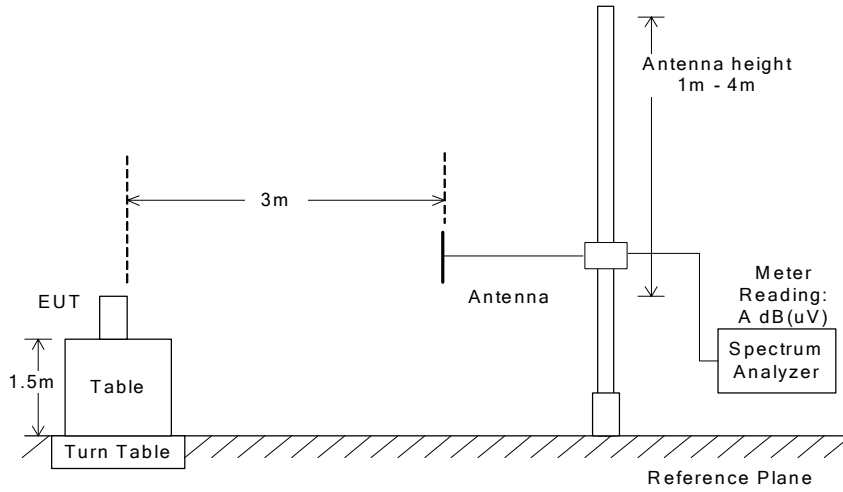

(a)EUT

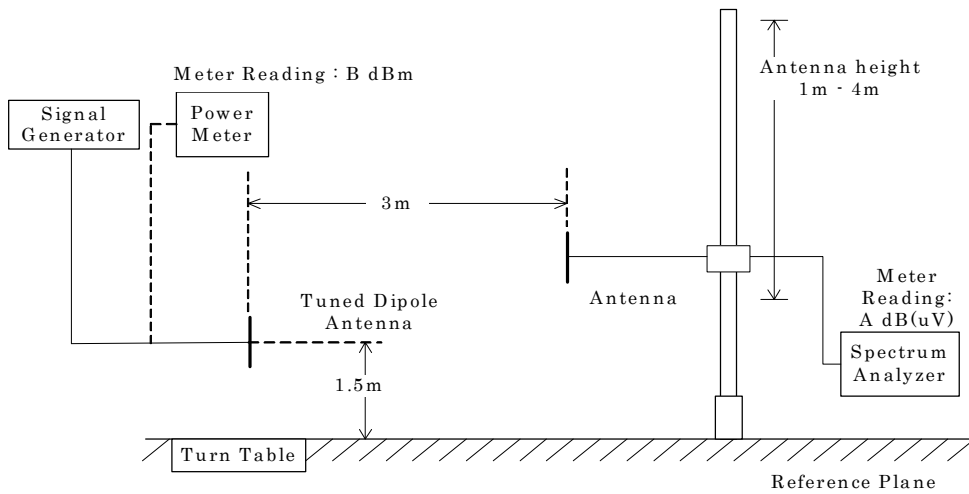

(b) Substitution Half-wave Dipole Antenna

7.2.4 Test Data

a) Main Antenna

1) BW 5MHz(1RB)

Mode: QPSK

(LTE 5MHz)QPSK

Test Date: March 21, 2015

Temp.: 21 °C, Humi: 45 %

1. Measurement Results

CH	Transmitting Frequency [MHz]	Emission Measurement [dB(uV)]		Substitution Measurement [dB(uV)]		Supplied Power to Substitution Antenna [dBm]	Balun Loss of Substitution Antenna [dB]
		Hori. (Mh)	Vert. (Mv)	Hori. (Msh)	Vert. (Msv)		
23755	706.500	92.0	88.5	68.1	66.6	- 5.0	-1.5
23790	710.000	92.8	89.0	68.1	66.7	- 5.0	-1.5
23825	713.500	91.7	87.6	68.2	66.7	- 5.0	-1.5

2. Calculation Results

CH	Transmitting Frequency [MHz]	Average ERP [dBm]		Maximum Average ERP [W]	Limits [dBm]	Margin [dB]
		Hori. (ERPh)	Vert. (ERPv)			
23755	706.500	20.4	18.4	0.110	34.8	+14.4
23790	710.000	21.2	18.8	0.132	34.8	+13.6
23825	713.500	20.0	17.4	0.100	34.8	+14.8

Calculated result at 710.000 MHz, as the worst point shown on underline:

Emission Measurement (Mh)	=	92.8 dB(uV)
Substitution Measurement (Msh)	=	-68.1 dB(uV)
Supplied Power to Substitution Antenna	=	-5.0 dBm
+) Balun Loss of Substitution Antenna	=	1.5 dB
Result (ERPh)	=	21.2 dBm = 0.132 W

Minimum Margin: 34.8 - 21.2 = 13.6 (dB)

NOTE : Setting of measuring instrument(s) :

Detector Function
RMS

Mode: 16QAM

(LTE 5MHz)16QAM

Test Date: March 21, 2015

Temp: 21 °C, Humi: 45 %

1. Measurement Results

CH	Transmitting Frequency [MHz]	Emission Measurement [dB(uV)]		Substitution Measurement [dB(uV)]		Supplied Power to Substitution Antenna [dBm]	Balun Loss of Substitution Antenna [dB]
		Hori. (Mh)	Vert. (Mv)	Hori. (Msh)	Vert. (Msv)		
23755	706.500	91.1	87.7	68.1	66.6	- 5.0	-1.5
23790	710.000	92.1	88.5	68.1	66.7	- 5.0	-1.5
23825	713.500	91.0	86.9	68.2	66.7	- 5.0	-1.5

2. Calculation Results

CH	Transmitting Frequency [MHz]	Average ERP [dBm]		Maximum Average ERP [W]	Limits [dBm]	Margin [dB]
		Hori. (ERPh)	Vert. (ERPv)			
23755	706.500	19.5	17.6	0.089	34.8	+15.3
23790	710.000	20.5	18.3	0.112	34.8	+14.3
23825	713.500	19.3	16.7	0.085	34.8	+15.5

Calculated result at 710.000 MHz, as the worst point shown on underline:

Emission Measurement (Mh)	=	92.1 dB(uV)
Substitution Measurement (Msh)	=	-68.1 dB(uV)
Supplied Power to Substitution Antenna	=	-5.0 dBm
+) Balun Loss of Substitution Antenna	=	1.5 dB
Result (ERPh)	=	20.5 dBm = 0.112 W

Minimum Margin: 34.8 - 20.5 = 14.3 (dB)

NOTE : Setting of measuring instrument(s) :

Detector Function
RMS

2) BW 10MHz(1RB)

Mode: QPSK

(LTE 10MHz)QPSK

Test Date: March 21, 2015

Temp.: 21 °C, Humi: 45 %

1. Measurement Results

Transmitting Frequency		Emission Measurement [dB(uV)]		Substitution Measurement [dB(uV)]		Supplied Power to Substitution Antenna [dBm]	Balun Loss of Substitution Antenna [dB]
CH	[MHz]	Hori. (Mh)	Vert. (Mv)	Hori. (Msh)	Vert. (Msv)		
23780	709.000	92.9	89.3	68.1	66.7	- 5.0	-1.4
23790	710.000	92.8	89.2	68.1	66.7	- 5.0	-1.5
23800	711.000	92.5	88.6	68.2	66.8	- 5.0	-1.5

2. Calculation Results

Transmitting Frequency CH	[MHz]	Average ERP [dBm]		Maximum Average ERP [W]	Limits [dBm]	Margin [dB]
		Hori. (ERPh)	Vert. (ERPv)			
23780	709.000	21.2	19.0	0.132	34.8	+13.6
23790	710.000	21.2	19.0	0.132	34.8	+13.6
23800	711.000	20.8	18.3	0.120	34.8	+14.0

Calculated result at 709.000 MHz, as the worst point shown on underline:

Emission Measurement (Mh)	=	92.9 dB(uV)
Substitution Measurement (Msh)	=	-68.1 dB(uV)
Supplied Power to Substitution Antenna	=	-5.0 dBm
+) Balun Loss of Substitution Antenna	=	1.4 dB
Result (ERPh)	=	21.2 dBm = 0.132 W

Minimum Margin: 34.8 - 21.2 = 13.6 (dB)

NOTE : Setting of measuring instrument(s) :

Detector Function
RMS

Mode: 16QAM

(LTE 10MHz) 16QAM

Test Date: March 21, 2015

Temp: 21 °C, Humi: 45 %

1. Measurement Results

CH	Transmitting Frequency [MHz]	Emission Measurement [dB(uV)]		Substitution Measurement [dB(uV)]		Supplied Power to Substitution Antenna [dBm]	Balun Loss of Substitution Antenna [dB]
		Hori. (Mh)	Vert. (Mv)	Hori. (Msh)	Vert. (Msv)		
23780	709.000	92.2	88.8	68.1	66.7	- 5.0	-1.4
23790	710.000	92.1	88.6	68.1	66.7	- 5.0	-1.5
23800	711.000	91.8	88.1	68.2	66.8	- 5.0	-1.5

2. Calculation Results

CH	Transmitting Frequency [MHz]	Average ERP [dBm]		Maximum Average ERP [W]	Limits [dBm]	Margin [dB]
		Hori. (ERPh)	Vert. (ERPv)			
23780	709.000	20.5	18.5	0.112	34.8	+14.3
23790	710.000	20.5	18.4	0.112	34.8	+14.3
23800	711.000	20.1	17.8	0.102	34.8	+14.7

Calculated result at 709.000 MHz, as the worst point shown on underline:

Emission Measurement (Mh)	=	92.2 dB(uV)
Substitution Measurement (Msh)	=	-68.1 dB(uV)
Supplied Power to Substitution Antenna	=	-5.0 dBm
+) Balun Loss of Substitution Antenna	=	1.4 dB
Result (ERPh)	=	20.5 dBm = 0.112 W

Minimum Margin: 34.8 - 20.5 = 14.3 (dB)

NOTE : Setting of measuring instrument(s) :

Detector Function
RMS

b) Sub Antenna

1) BW 5MHz(1RB)

Mode: QPSK

(LTE 5MHz)QPSK

Test Date: March 21, 2015

Temp: 21 °C, Humi: 45 %

1. Measurement Results

CH	Transmitting Frequency [MHz]	Emission Measurement [dB(uV)]		Substitution Measurement [dB(uV)]		Supplied Power to Substitution Antenna [dBm]	Balun Loss of Substitution Antenna [dB]
		Hori. (Mh)	Vert. (Mv)	Hori. (Msh)	Vert. (Msv)		
23755	706.500	85.0	80.4	68.1	66.6	- 5.0	-1.5
23790	710.000	84.2	80.2	68.1	66.7	- 5.0	-1.5
23825	713.500	85.9	82.5	68.2	66.7	- 5.0	-1.5

2. Calculation Results

CH	Transmitting Frequency [MHz]	Average ERP [dBm]		Maximum Average ERP [W]	Limits [dBm]	Margin [dB]
		Hori. (ERPh)	Vert. (ERPv)			
23755	706.500	13.4	10.3	0.022	34.8	+21.4
23790	710.000	12.6	10.0	0.018	34.8	+22.2
23825	713.500	14.2	12.3	0.026	34.8	+20.6

Calculated result at 713.500 MHz, as the worst point shown on underline:

Emission Measurement (Mh)	=	85.9 dB(uV)
Substitution Measurement (Msh)	=	-68.2 dB(uV)
Supplied Power to Substitution Antenna	=	-5.0 dBm
+) <u>Balun Loss of Substitution Antenna</u>	=	1.5 dB
Result (ERPh)	=	14.2 dBm = 0.026 W

Minimum Margin: 34.8 - 14.2 = 20.6 (dB)

NOTE : Setting of measuring instrument(s) :

Detector Function
RMS

Mode: 16QAM

(LTE 5MHz)16QAM

Test Date: March 21, 2015

Temp: 21 °C, Humi: 45 %

1. Measurement Results

CH	Transmitting Frequency [MHz]	Emission Measurement [dB(uV)]		Substitution Measurement [dB(uV)]		Supplied Power to Substitution Antenna [dBm]	Balun Loss of Substitution Antenna [dB]
		Hori. (Mh)	Vert. (Mv)	Hori. (Msh)	Vert. (Msv)		
23755	706.500	84.2	79.7	68.1	66.6	- 5.0	-1.5
23790	710.000	83.3	79.5	68.1	66.7	- 5.0	-1.5
23825	713.500	85.1	81.5	68.2	66.7	- 5.0	-1.5

2. Calculation Results

CH	Transmitting Frequency [MHz]	Average ERP [dBm]		Maximum Average ERP [W]	Limits [dBm]	Margin [dB]
		Hori. (ERPh)	Vert. (ERPv)			
23755	706.500	12.6	9.6	0.018	34.8	+22.2
23790	710.000	11.7	9.3	0.015	34.8	+23.1
23825	713.500	13.4	11.3	0.022	34.8	+21.4

Calculated result at 713.500 MHz, as the worst point shown on underline:

Emission Measurement (Mh)	=	85.1 dB(uV)
Substitution Measurement (Msh)	=	-68.2 dB(uV)
Supplied Power to Substitution Antenna	=	-5.0 dBm
+) Balun Loss of Substitution Antenna	=	1.5 dB
Result (ERPh)	=	13.4 dBm = 0.022 W

Minimum Margin: 34.8 - 13.4 = 21.4 (dB)

NOTE : Setting of measuring instrument(s) :

Detector Function
RMS

2) BW 10MHz(1RB)

Mode: QPSK

(LTE 10MHz)QPSK

Test Date: March 21, 2015

Temp.: 21 °C, Humi: 45 %

1. Measurement Results

Transmitting Frequency		Emission Measurement [dB(uV)]		Substitution Measurement [dB(uV)]		Supplied Power to Substitution Antenna [dBm]	Balun Loss of Substitution Antenna [dB]
CH	[MHz]	Hori. (Mh)	Vert. (Mv)	Hori. (Msh)	Vert. (Msv)		
23780	709.000	84.4	80.5	68.1	66.7	- 5.0	-1.4
23790	710.000	84.2	80.4	68.1	66.7	- 5.0	-1.5
23800	711.000	84.2	80.6	68.2	66.8	- 5.0	-1.5

2. Calculation Results

Transmitting Frequency CH	[MHz]	Average ERP [dBm]		Maximum Average ERP [W]	Limits [dBm]	Margin [dB]
		Hori. (ERPh)	Vert. (ERPv)			
23780	709.000	12.7	10.2	0.019	34.8	+22.1
23790	710.000	12.6	10.2	0.018	34.8	+22.2
23800	711.000	12.5	10.3	0.018	34.8	+22.3

Calculated result at 709.000 MHz, as the worst point shown on underline:

Emission Measurement (Mh)	=	84.4 dB(uV)
Substitution Measurement (Msh)	=	-68.1 dB(uV)
Supplied Power to Substitution Antenna	=	-5.0 dBm
+) Balun Loss of Substitution Antenna	=	1.4 dB
Result (ERPh)	=	12.7 dBm = 0.019 W

Minimum Margin: 34.8 - 12.7 = 22.1 (dB)

NOTE : Setting of measuring instrument(s) :

Detector Function
RMS

Mode: 16QAM

(LTE 10MHz) 16QAM

Test Date: March 21, 2015

Temp: 21 °C, Humi: 45 %

1. Measurement Results

Transmitting Frequency		Emission Measurement [dB(uV)]		Substitution Measurement [dB(uV)]		Supplied Power to Substitution Antenna [dBm]	Balun Loss of Substitution Antenna [dB]
CH	[MHz]	Hori. (Mh)	Vert. (Mv)	Hori. (Msh)	Vert. (Msv)		
23780	709.000	83.6	79.6	68.1	66.7	- 5.0	-1.4
23790	710.000	83.3	79.6	68.1	66.7	- 5.0	-1.5
23800	711.000	83.4	79.7	68.2	66.8	- 5.0	-1.5

2. Calculation Results

Transmitting Frequency		Average ERP [dBm]		Maximum Average ERP [W]	Limits [dBm]	Margin [dB]
CH	[MHz]	Hori. (ERPh)	Vert. (ERPv)			
23780	709.000	11.9	9.3	0.015	34.8	+22.9
23790	710.000	11.7	9.4	0.015	34.8	+23.1
23800	711.000	11.7	9.4	0.015	34.8	+23.1

Calculated result at 709.000 MHz, as the worst point shown on underline:

Emission Measurement (Mh)	=	83.6 dB(uV)
Substitution Measurement (Msh)	=	-68.1 dB(uV)
Supplied Power to Substitution Antenna	=	-5.0 dBm
+) Balun Loss of Substitution Antenna	=	1.4 dB
Result (ERPh)	=	11.9 dBm = 0.015 W

Minimum Margin: 34.8 - 11.9 = 22.9 (dB)

NOTE : Setting of measuring instrument(s) :

Detector Function
RMS

7.3 Modulation Characteristics (§2.1047)

For the requirements, - Applicable - Tested. - Not tested by applicant request.]
 - Not Applicable

For the limits, - Passed - Failed - Not judged

7.4 Occupied Bandwidth (§2.1049)

For the requirements, - Applicable - Tested. - Not tested by applicant request.]
 - Not Applicable

For the limits, - Passed - Failed - Not judged

7.4.1 Worst Point and Measurement Uncertainty

The 99% Bandwidth of BW: 5 MHz(QPSK) is	<u>4.49</u>	MHz	at	<u>706.50</u>	MHz
The 99% Bandwidth of BW: 5 MHz(16QAM) is	<u>4.48</u>	MHz	at	<u>706.50</u>	MHz
The 99% Bandwidth of BW: 10 MHz(QPSK) is	<u>8.93</u>	MHz	at	<u>709/711</u>	MHz
The 99% Bandwidth of BW: 10 MHz(16QAM) is	<u>8.94</u>	kHz	at	<u>709.00</u>	MHz
The 26dB Bandwidth of 5 MHz(QPSK) is	<u>4.91</u>	MHz	at	<u>706.5/713.5</u>	MHz
The 26dB Bandwidth of 5 MHz(16QAM) is	<u>4.88</u>	MHz	at	<u>706.50</u>	MHz
The 26dB Bandwidth of 10 MHz(QPSK) is	<u>9.70</u>	MHz	at	<u>711.00</u>	MHz
The 26dB Bandwidth of 10 MHz(16QAM) is	<u>9.70</u>	kHz	at	<u>709.00</u>	MHz
Uncertainty of Measurement Results				<u>+/-0.9</u>	%(2σ)

Remarks : _____

7.4.2 Test Site and Instruments

7.4.2.1 Test Site

KITA-KANSAI Testing Center

Test site : SAITO - Anechoic chamber (A1) - Measurement room (M1)
 - Measurement room (M2) - Measurement room (M3)
 - Shielded room (S1) - Shielded room (S2)
 - Shielded room (S3) - Shielded room (S4)

7.4.2.2 Test Instruments

Type	Model	Manufacturer	ID No.	Last Cal.	Interval
Spectrum Analyzer	E4446A	Agilent	A-39	2014/9	1 Year
Attenuator	43KC-20	Anritsu	D-41	2014/7	1 Year
RF Cable	SUCOFLEX102	SUHNER	C-52	2014/8	1 Year

7.4.3 Test Method and Test Setup (Diagrammatic illustration)

The test system is shown as follows:

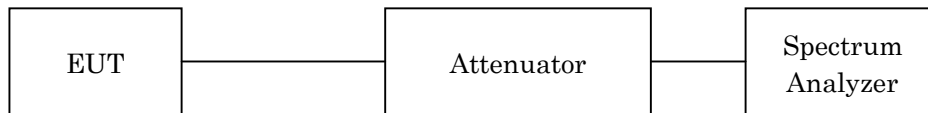

The setting of the spectrum analyzer are shown as follows:

LTE. Bandwidth	5 MHz	10 MHz
Res. Bandwidth	51 kHz	100 kHz
Video Bandwidth	160 kHz	300 kHz
Span	10 MHz	20 MHz
Sweep Time	AUTO	AUTO
Trace	Maxhold	Maxhold

7.4.4 Test Data

The resolution bandwidth was set to about 1 – 5 % of emission bandwidth, -26dBc display line was placed on the screen (or 99% bandwidth), the occupied bandwidth is the delta frequency between the two points where the display line intersects the signal trace.

a) Main Antenna

Test Date : March 16, 2015

Temp.:22°C, Humi:45%

1) BW 5MHz(Full RB)

Mode: QPSK

Channel	Frequency (MHz)	99% Bandwidth (MHz)	-26dBc Bandwidth (MHz)
23755	706.50	4.49	4.90
23790	710.00	4.47	4.89
23825	713.50	4.48	4.91

Low Channel

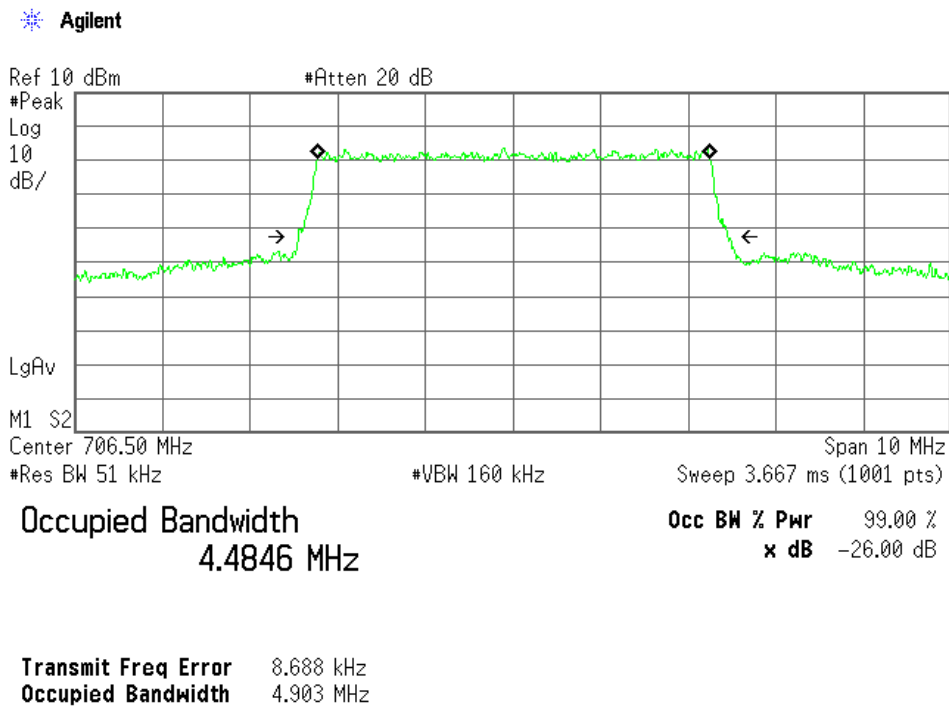

Middle Channel

Agilent

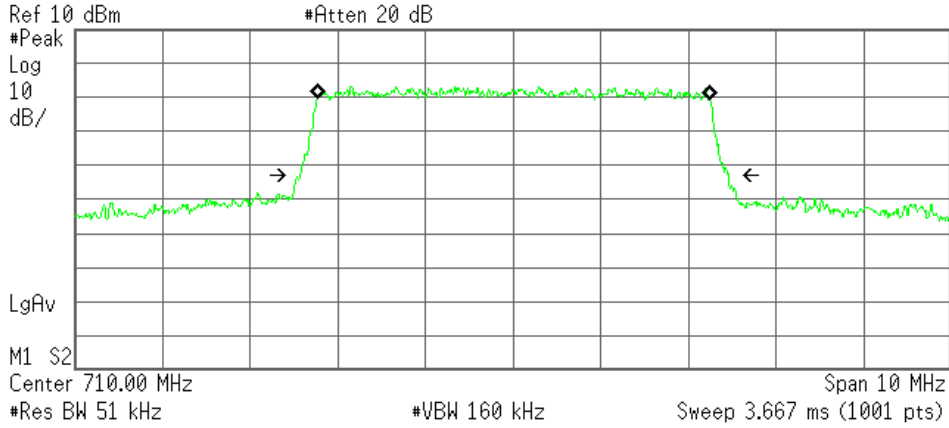

Occupied Bandwidth
4.4741 MHz

Occ BW % Pwr 99.00 %
x dB -26.00 dB

Transmit Freq Error 3.683 kHz
Occupied Bandwidth 4.890 MHz

High Channel

Agilent

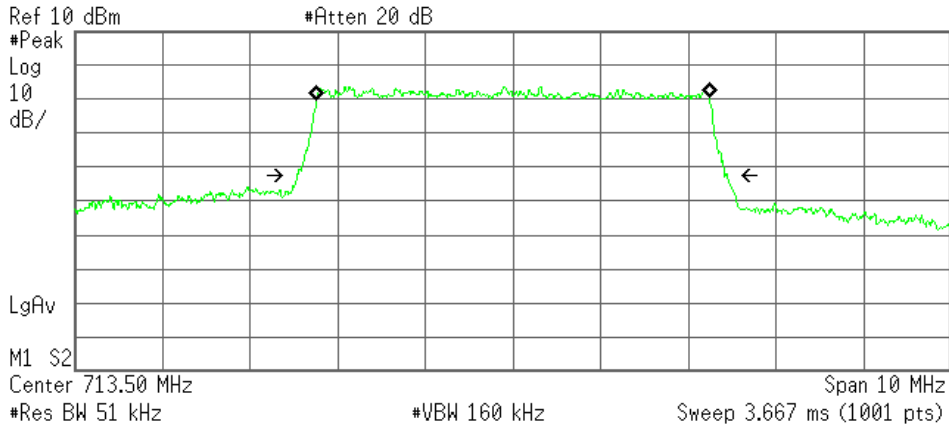

Occupied Bandwidth
4.4781 MHz

Occ BW % Pwr 99.00 %
x dB -26.00 dB

Transmit Freq Error 266.056 Hz
Occupied Bandwidth 4.911 MHz

Mode: 16QAM

Channel	Frequency (MHz)	99% Bandwidth (MHz)	-26dBc Bandwidth (MHz)
23755	706.50	4.48	4.88
23790	710.00	4.47	4.86
23825	713.50	4.47	4.84

Low Channel

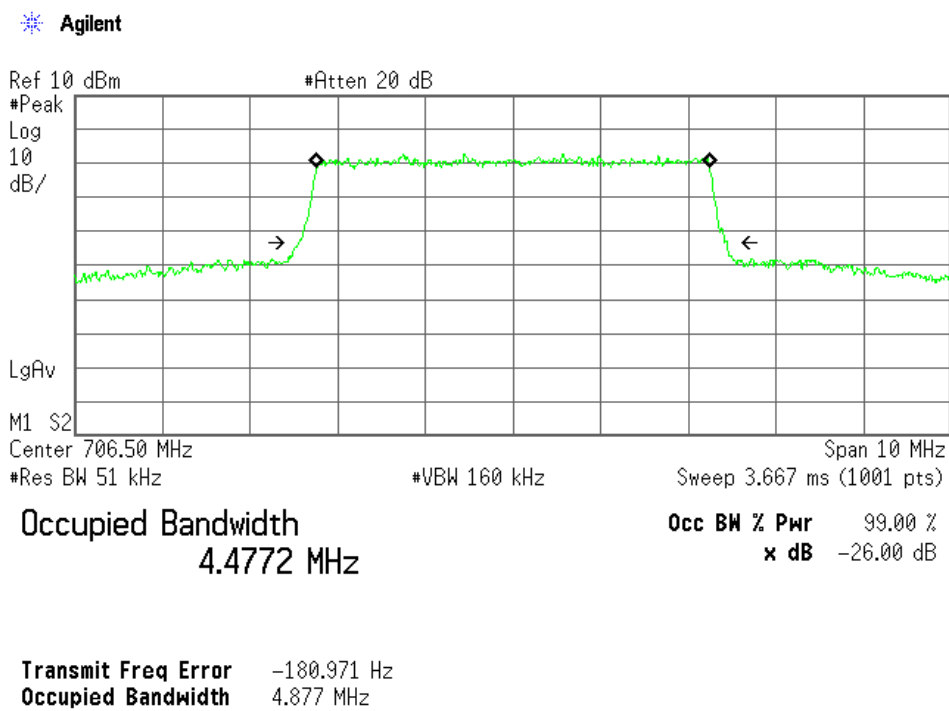

Middle Channel

* Agilent

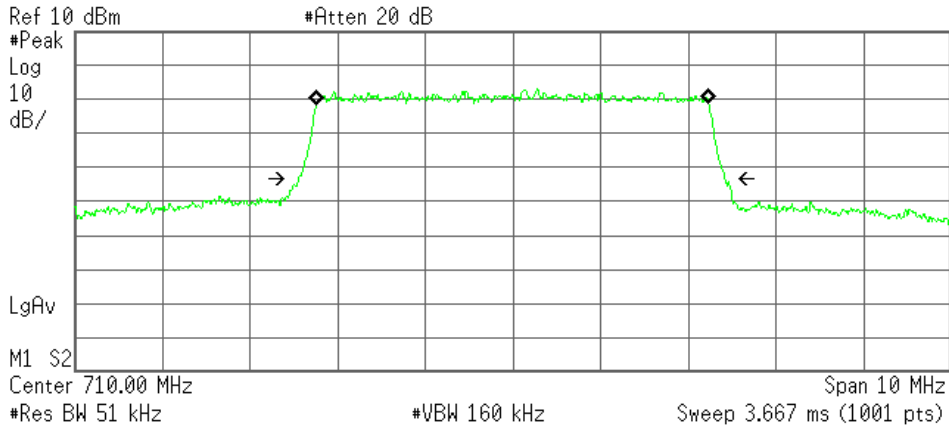

Occupied Bandwidth
 4.4697 MHz

Occ BW % Pwr 99.00 %
x dB -26.00 dB

Transmit Freq Error -4.209 kHz
Occupied Bandwidth 4.864 MHz

High Channel

* Agilent

L

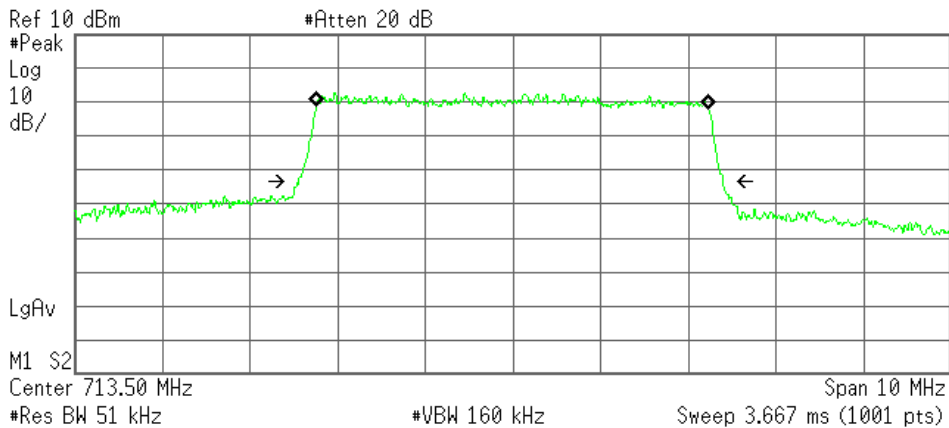

Occupied Bandwidth
 4.4725 MHz

Occ BW % Pwr 99.00 %
x dB -26.00 dB

Transmit Freq Error -7.179 kHz
Occupied Bandwidth 4.841 MHz

2) BW 10MHz(Full RB)

Mode: QPSK

Channel	Frequency (MHz)	99% Bandwidth (MHz)	-26dBc Bandwidth (MHz)
23780	709.00	8.91	9.61
23790	710.00	8.91	9.58
23800	711.00	8.92	9.70

Low Channel

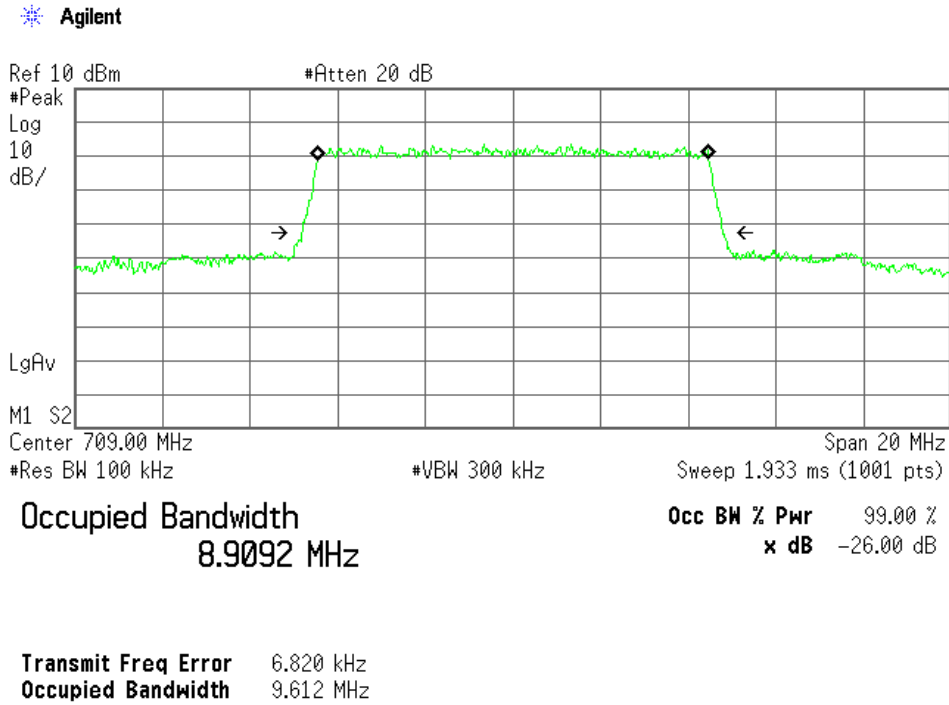

Middle Channel

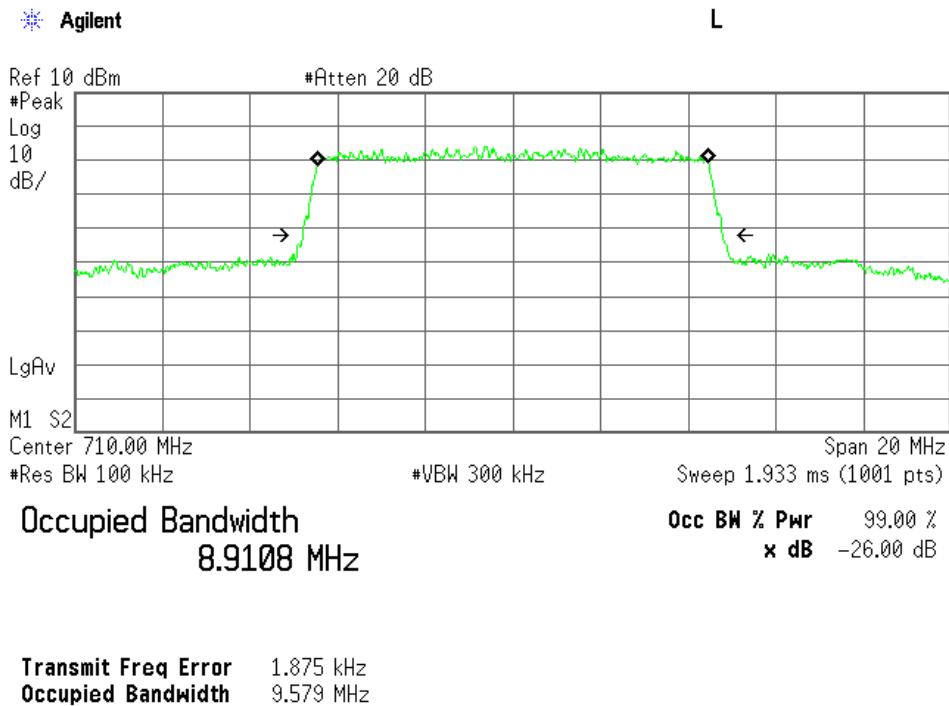

High Channel

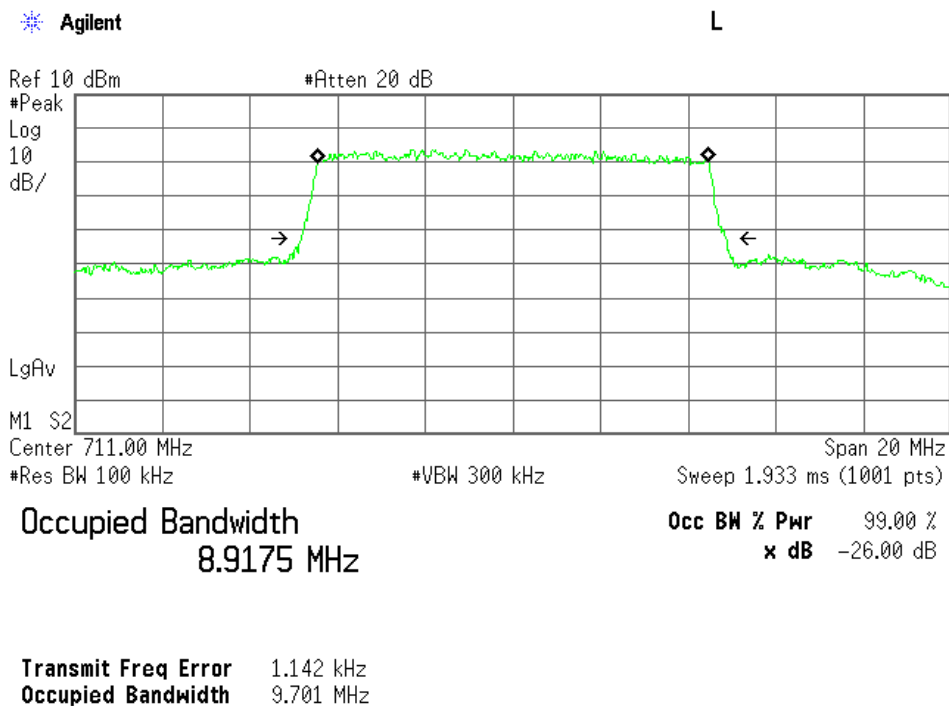

Mode: 16QAM

Channel	Frequency (MHz)	99% Bandwidth (MHz)	-26dBc Bandwidth (MHz)
23780	709.00	8.94	9.67
23790	710.00	8.92	9.62
23800	711.00	8.94	9.69

Low Channel

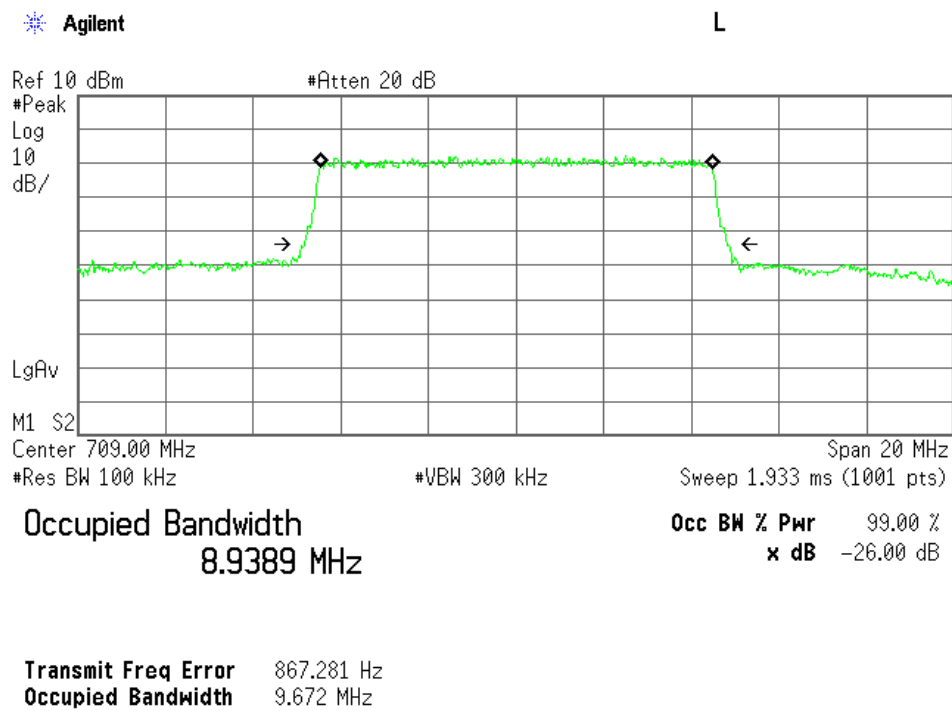

Middle Channel

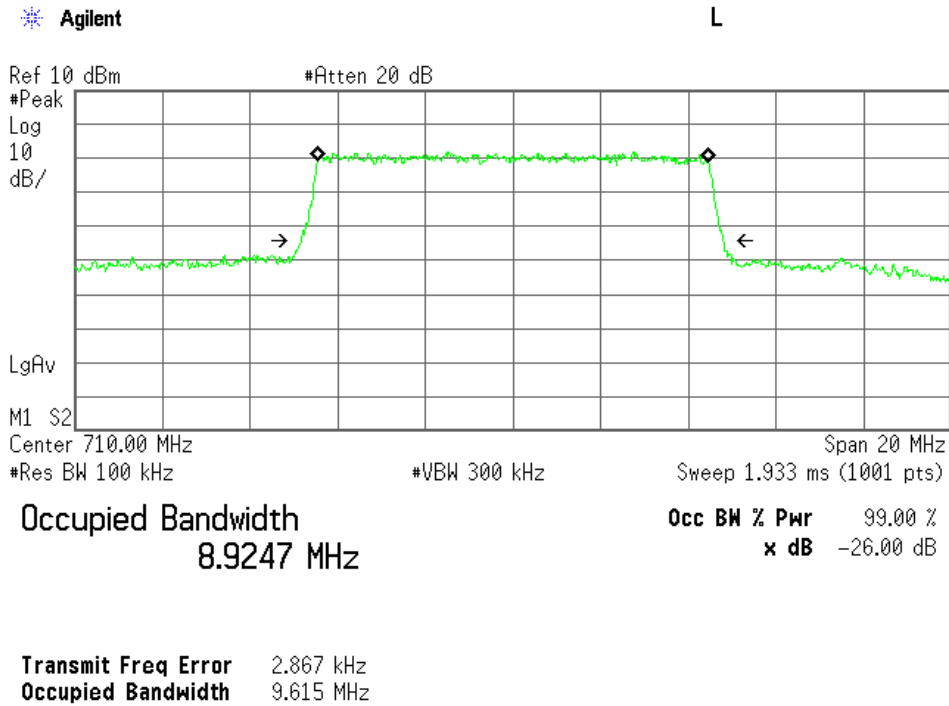

High Channel

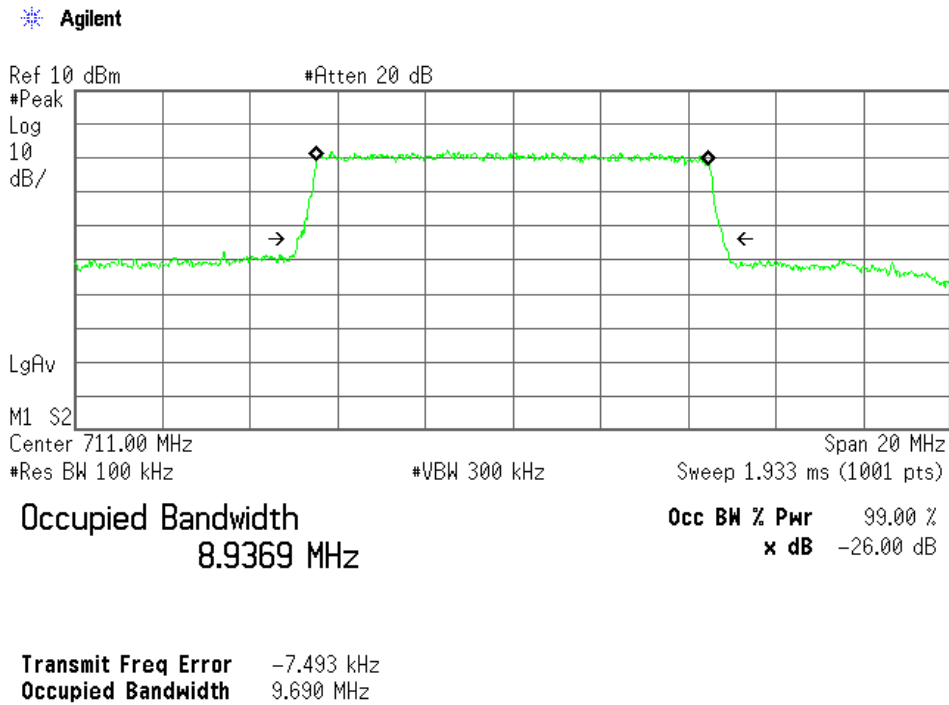

b) Sub Antenna

Test Date : March 24, 2015

Temp.:22°C, Humi:30%

1) BW 5MHz(Full RB)

Mode: QPSK

Channel	Frequency (MHz)	99% Bandwidth (MHz)	-26dBc Bandwidth (MHz)
23755	706.50	4.49	4.91
23790	710.00	4.48	4.89
23825	713.50	4.48	4.90

Low Channel

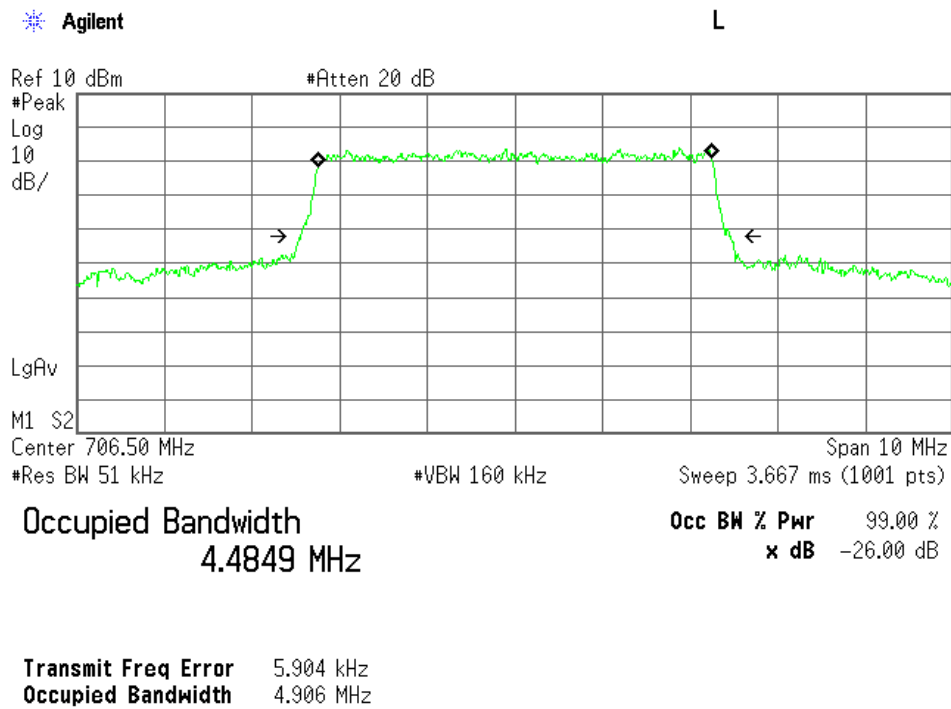

Middle Channel

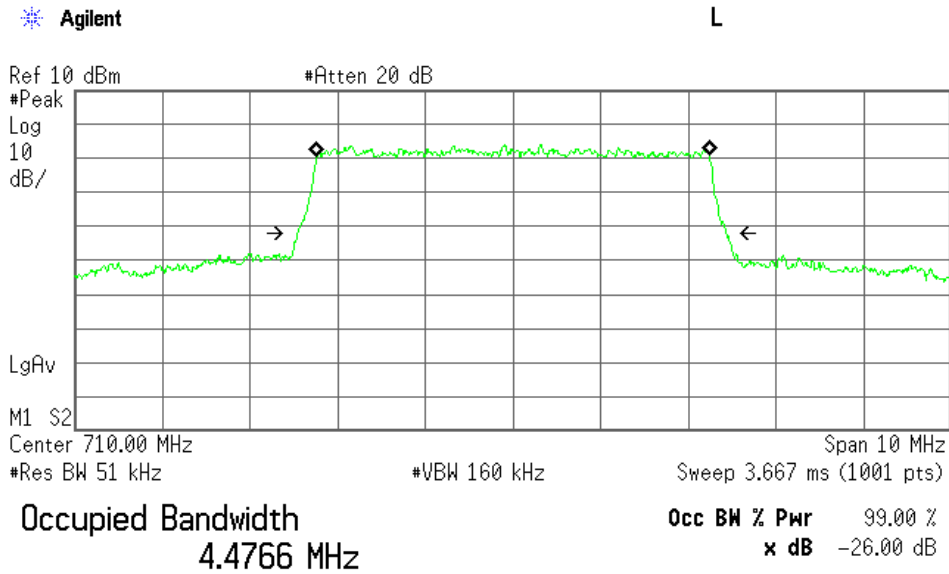

Transmit Freq Error 1.124 kHz
Occupied Bandwidth 4.894 MHz

High Channel

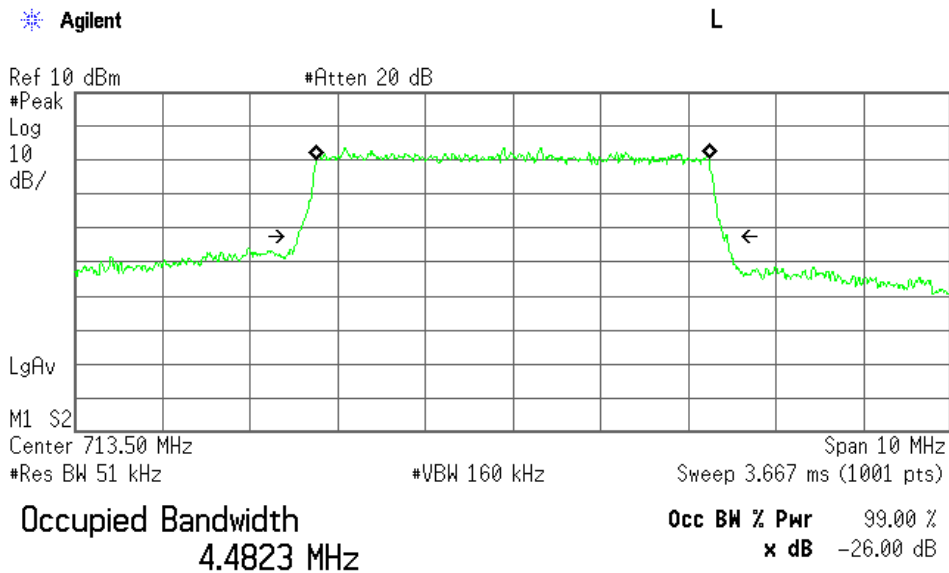

Transmit Freq Error -3.847 kHz
Occupied Bandwidth 4.899 MHz

Mode: 16QAM

Channel	Frequency (MHz)	99% Bandwidth (MHz)	-26dBc Bandwidth (MHz)
23755	706.50	4.47	4.86
23790	710.00	4.47	4.86
23825	713.50	4.47	4.86

Low Channel

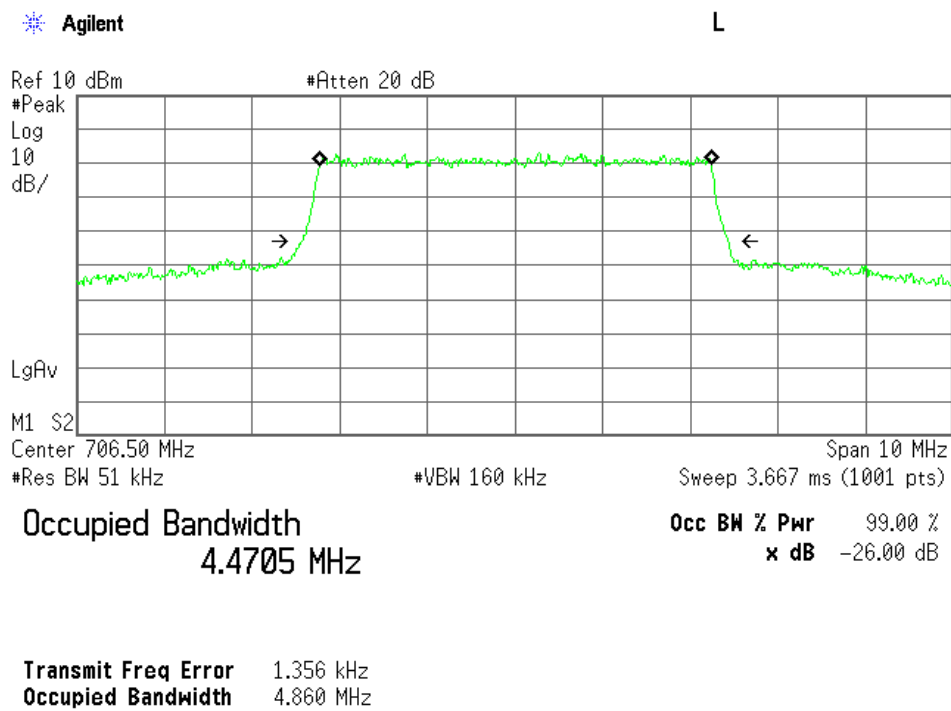

Middle Channel

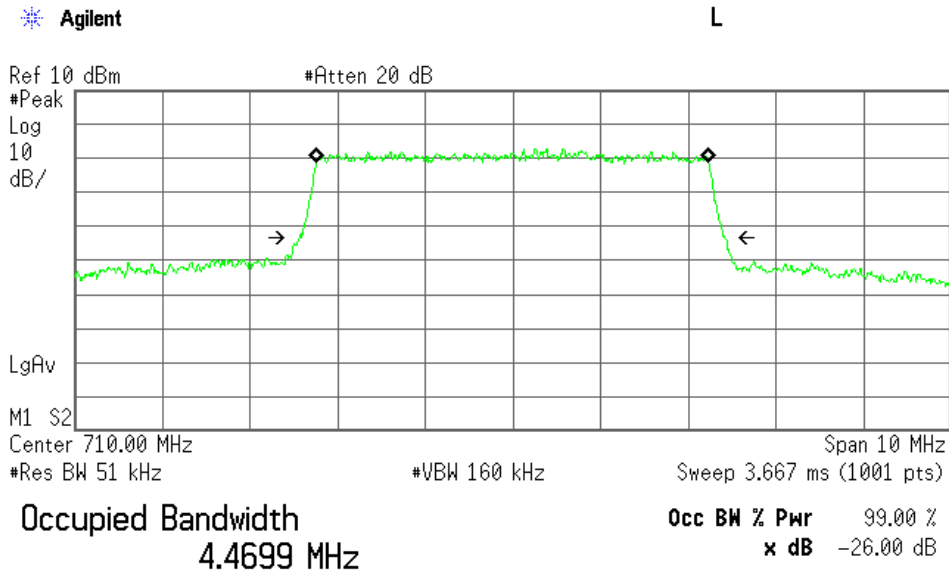

Transmit Freq Error -4.081 kHz
Occupied Bandwidth 4.857 MHz

High Channel

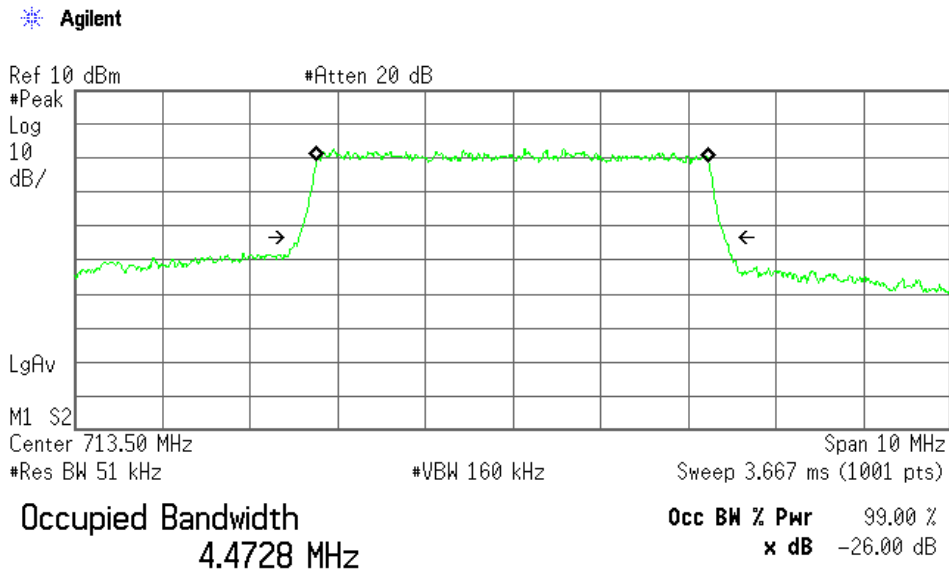

Transmit Freq Error -6.164 kHz
Occupied Bandwidth 4.862 MHz

2) BW 10MHz(Full RB)

Mode: QPSK

Channel	Frequency (MHz)	99% Bandwidth (MHz)	-26dBc Bandwidth (MHz)
23780	709.00	8.93	9.64
23790	710.00	8.91	9.63
23800	711.00	8.93	9.59

Low Channel

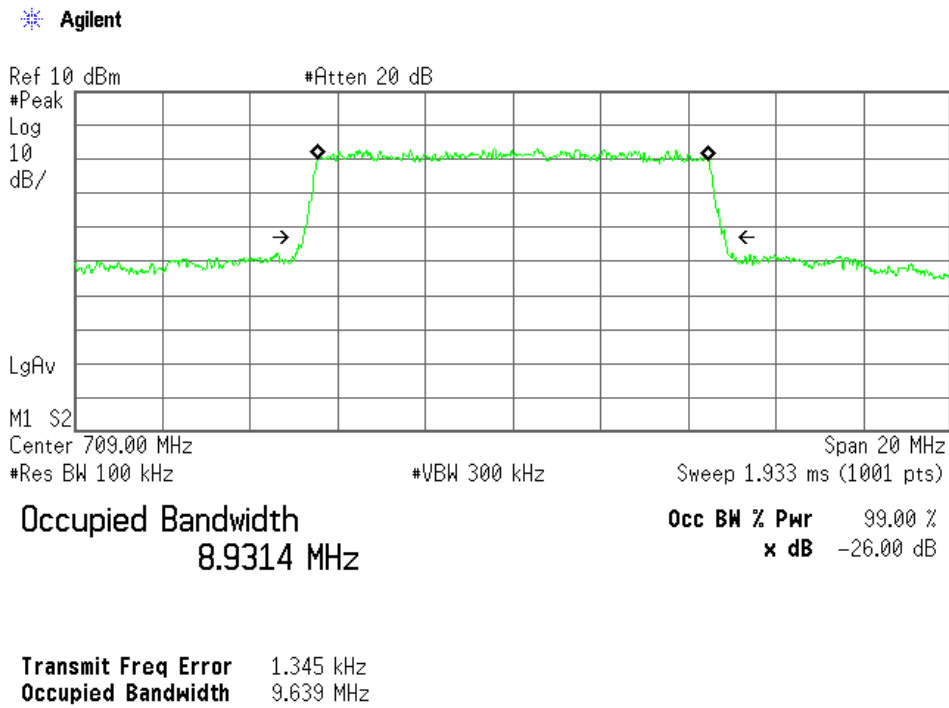

Middle Channel

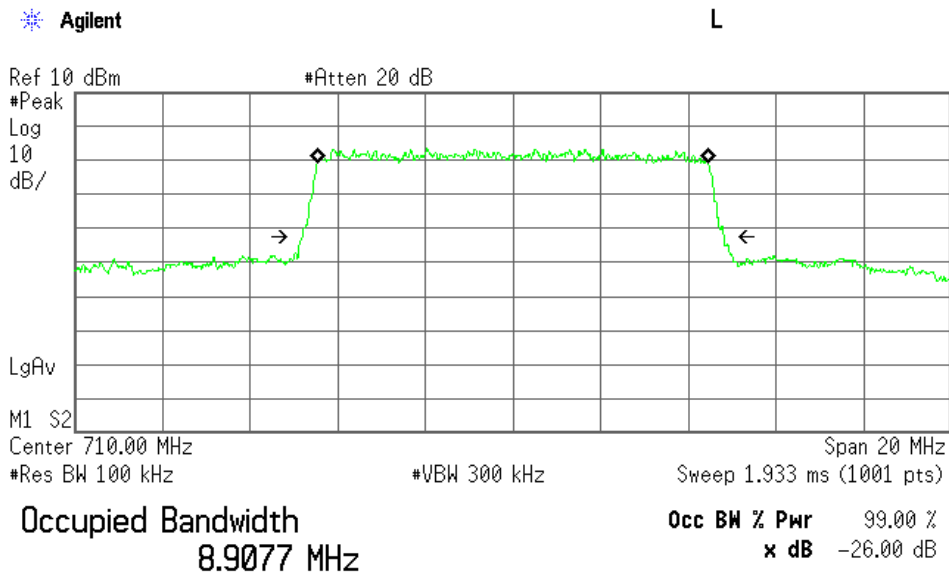

Transmit Freq Error 1.638 kHz
Occupied Bandwidth 9.631 MHz

High Channel

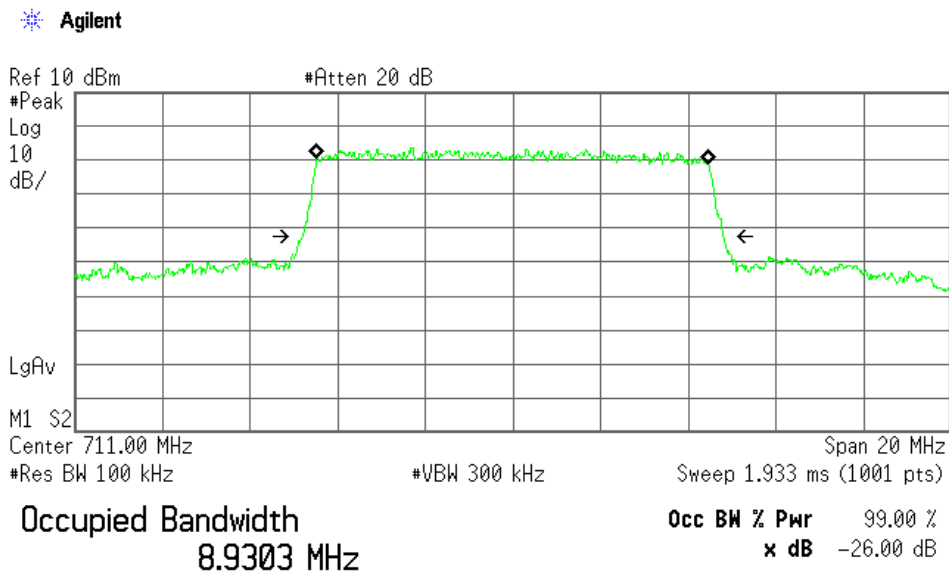

Transmit Freq Error -10.058 kHz
Occupied Bandwidth 9.592 MHz

Mode: 16QAM

Channel	Frequency (MHz)	99% Bandwidth (MHz)	-26dBc Bandwidth (MHz)
23780	709.00	8.94	9.70
23790	710.00	8.93	9.61
23800	711.00	8.93	9.61

Low Channel

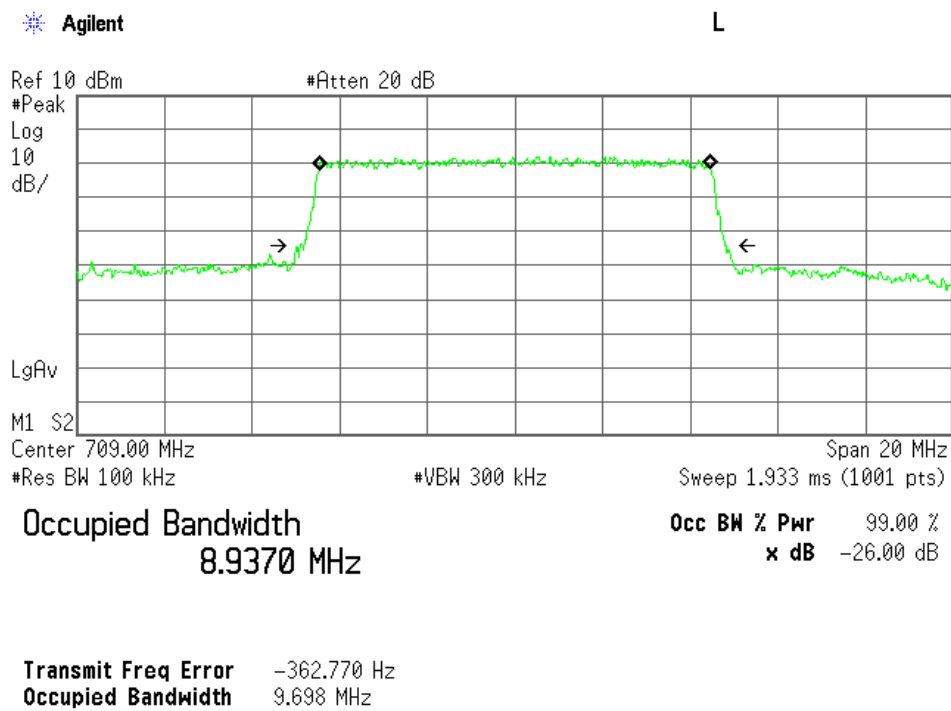

Middle Channel

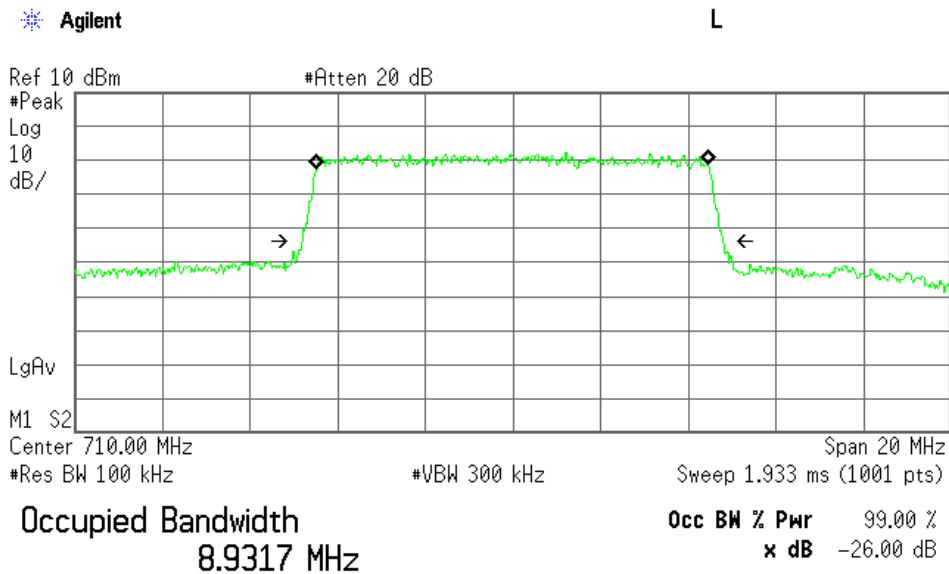

Transmit Freq Error -6.661 kHz
Occupied Bandwidth 9.608 MHz

High Channel

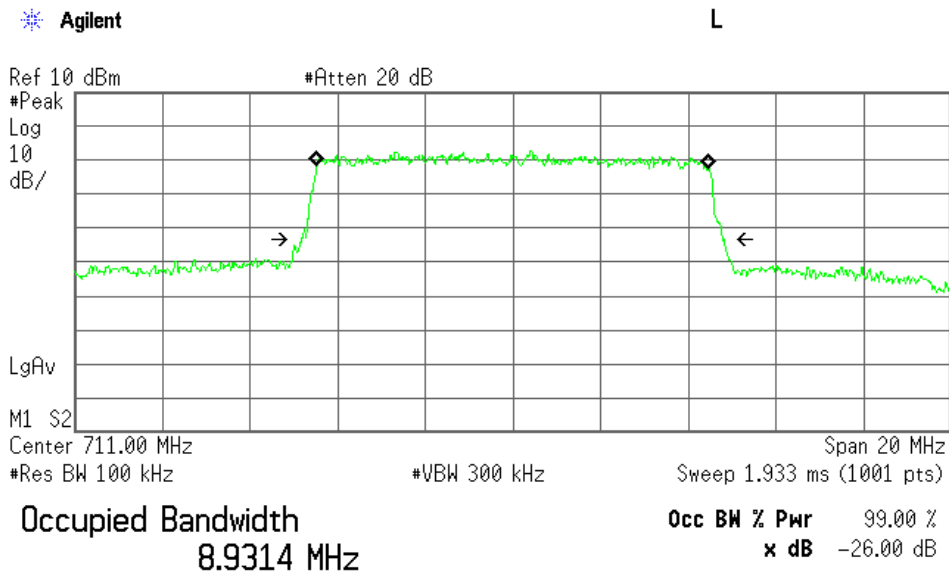

Transmit Freq Error -4.743 kHz
Occupied Bandwidth 9.609 MHz

7.5 Spurious Emissions at Antenna Terminals (§2.1051)

For the requirements, - Applicable - Tested. - Not tested by applicant request.]
 - Not Applicable

For the limits, - Passed - Failed - Not judged

7.5.1 Worst Point and Measurement Uncertainty

Min. Limit Margin >35.2 dB at 7090/7100/
7110/7135 MHz

Uncertainty of Measurement Results

9 kHz – 1GHz	<u>+/-1.4</u>	dB(2 σ)
1GHz – 18GHz	<u>+/-1.7</u>	dB(2 σ)
18GHz – 40GHz	<u>+/-2.3</u>	dB(2 σ)

Remarks : _____

7.5.2 Test Site and Instruments**7.5.2.1 Test Site**

KITA-KANSAI Testing Center

Test site : SAITO

<input type="checkbox"/> - Anechoic chamber (A1)	<input type="checkbox"/> - Measurement room (M1)
<input type="checkbox"/> - Measurement room (M2)	<input type="checkbox"/> - Measurement room (M3)
<input type="checkbox"/> - Shielded room (S1)	<input type="checkbox"/> - Shielded room (S2)
<input type="checkbox"/> - Shielded room (S3)	<input checked="" type="checkbox"/> - Shielded room (S4)

7.5.2.2 Test Instruments

Type	Model	Manufacturer	ID No.	Last Cal.	Interval
Spectrum Analyzer	E4446A	Agilent	A-39	2014/9	1 Year
Attenuator	43KC-20	Anritsu	D-41	2014/7	1 Year
RF Cable	SUCOFLEX102	SUHNER	C-52	2014/8	1 Year
HPF	HPM5010S	MICRO-TRONICS	D-94	2015/2	1 Year

7.5.3 Test Method and Test Setup (Diagrammatic illustration)

The Antenna Conducted Emission was measured with a spectrum analyzer. The test system is shown as follows:

- a) Frequency Range: 9 kHz – 1.2 GHz

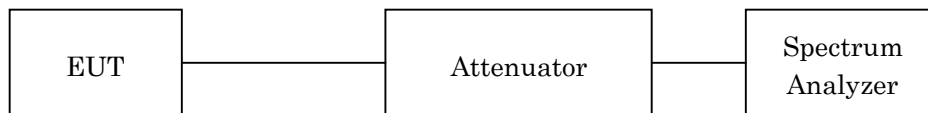

- b) Frequency Range: 1.2 GHz – 10 GHz

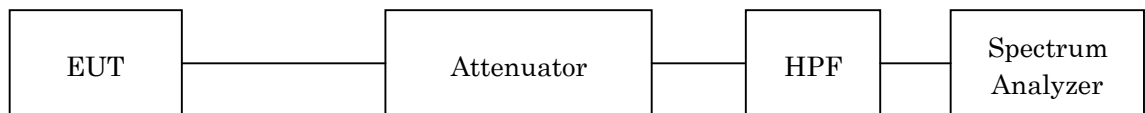

The setting of the spectrum analyzer are shown as follows:

Frequency Range	9 kHz - 150 kHz	150 kHz - 30 MHz	30 MHz - 10 GHz
Res. Bandwidth	200 Hz	10 kHz	1 MHz
Video Bandwidth	1 kHz	30 kHz	3 MHz
Sweep Time	AUTO	AUTO	AUTO
Trace	Maxhold	Maxhold	Maxhold

7.5.4 Test Data

a) Main Antenna

1) BW 5MHz(1RB)

(LTE 5MHz)

Test Date: March 16, 2015
 Temp.: 22 °C, Humi: 45 %

Transmitting Frequency CH	[MHz]	Measured Frequency [MHz]	Corr. Factor [dB]	Meter Readings [dBm]	Limits [dBm]	Results [dBm]	Margin [dB]	Remarks
23755	706.500	1413.000	21.7	< -70.0	-13.0	< -48.3	> +35.3	C
		2119.500	21.0	< -70.0	-13.0	< -49.0	> +36.0	C
		2826.000	21.2	< -70.0	-13.0	< -48.8	> +35.8	C
		3532.500	21.3	< -70.0	-13.0	< -48.7	> +35.7	C
		4239.000	21.4	< -70.0	-13.0	< -48.6	> +35.6	C
		4945.500	21.4	< -70.0	-13.0	< -48.6	> +35.6	C
		5652.000	21.5	< -70.0	-13.0	< -48.5	> +35.5	C
		6358.500	21.6	< -70.0	-13.0	< -48.4	> +35.4	C
23790	710.000	7065.000	21.7	< -70.0	-13.0	< -48.3	> +35.3	C
		1420.000	21.7	< -70.0	-13.0	< -48.3	> +35.3	C
		2130.000	21.0	< -70.0	-13.0	< -49.0	> +36.0	C
		2840.000	21.2	< -70.0	-13.0	< -48.8	> +35.8	C
		3550.000	21.3	< -70.0	-13.0	< -48.7	> +35.7	C
		4260.000	21.4	< -70.0	-13.0	< -48.6	> +35.6	C
		4970.000	21.5	< -70.0	-13.0	< -48.5	> +35.5	C
		5680.000	21.5	< -70.0	-13.0	< -48.5	> +35.5	C
23825	713.500	6390.000	21.6	< -70.0	-13.0	< -48.4	> +35.4	C
		7100.000	21.8	< -70.0	-13.0	< -48.2	> +35.2	C
		1427.000	21.7	< -70.0	-13.0	< -48.3	> +35.3	C
		2140.500	21.0	< -70.0	-13.0	< -49.0	> +36.0	C
		2854.000	21.2	< -70.0	-13.0	< -48.8	> +35.8	C
		3567.500	21.3	< -70.0	-13.0	< -48.7	> +35.7	C
		4281.000	21.4	< -70.0	-13.0	< -48.6	> +35.6	C
		4994.500	21.5	< -70.0	-13.0	< -48.5	> +35.5	C
5708.000	21.5	< -70.0	-13.0	< -48.5	> +35.5	C		
6421.500	21.6	< -70.0	-13.0	< -48.4	> +35.4	C		
7135.000	21.8	< -70.0	-13.0	< -48.2	> +35.2	C		

Calculated result at 7100.0 MHz, as the worst point shown on underline:

Corr. Factor	=	21.8 dB
+) Meter Reading	=	<-70.0 dBm
Result	=	<-48.2 dBm

Minimum Margin: -13.0 - (<-48.2) =>35.2 (dB)

NOTES

1. The spectrum was checked from 9 kHz to 10 GHz.
2. Applied limits : -13.0 [dBm] = $10\log(TP[mW]) - (43 + 10\log(tp[W])) = 10\log(TP[mW]) - (43 + (10 \log(TP[mW]) - 30))$
 where, $tp[W] = TP[mW] / 1000$: Transmitter power at antenna terminal
3. The correction factor is shown as follows:
 Corr. Factor [dB] = Cable Loss + 10dB Pad Att. [dB] (9 kHz - 2 GHz)
 Corr. Factor [dB] = Cable Loss + 10dB Pad Att. + High Pass Filter Loss (D-96) [dB] (over 2 GHz)
4. The symbol of "<" means "or less".
5. The symbol of ">" means "more than".
6. Setting of measuring instrument(s) :

	Detector Function	RES B.W.	V.B.W.	Sweep Time
A	Peak	200 Hz	1 kHz	AUTO
B	Peak	10 kHz	30 kHz	AUTO
C	Peak	1 MHz	3 MHz	AUTO

Low Channel, Out-Of-Band Emissions (9 kHz – 150 kHz)

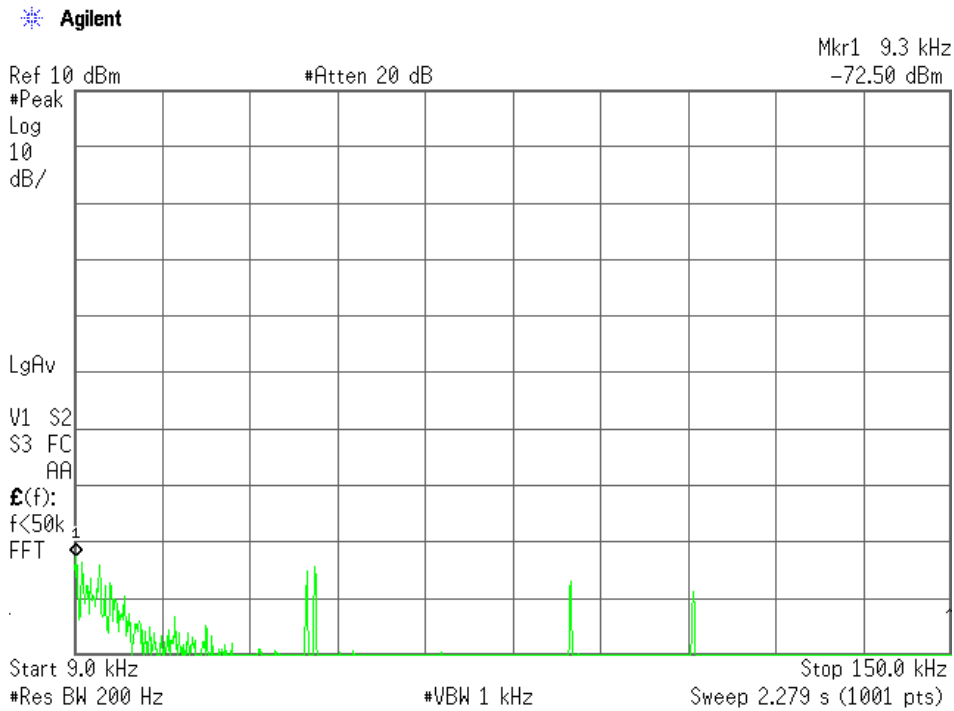

Low Channel, Out-Of-Band Emissions (150 kHz – 30 MHz)

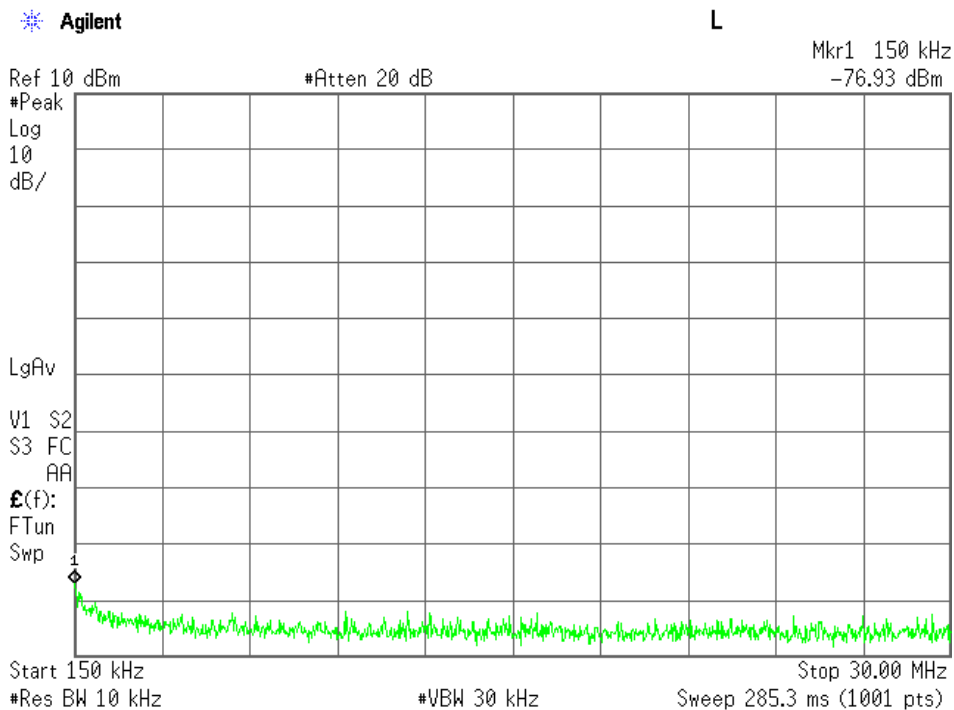

Low Channel, Out-Of-Band Emissions (30 MHz – 1.2 GHz)

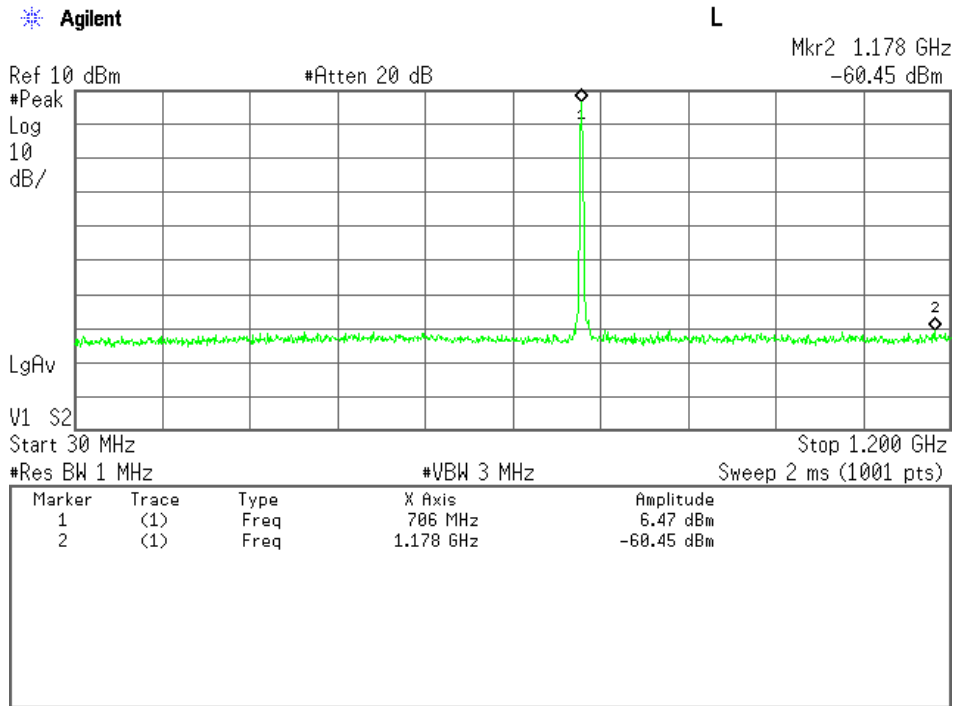

Low Channel, Out-Of-Band Emissions (1.2 GHz – 10 GHz)

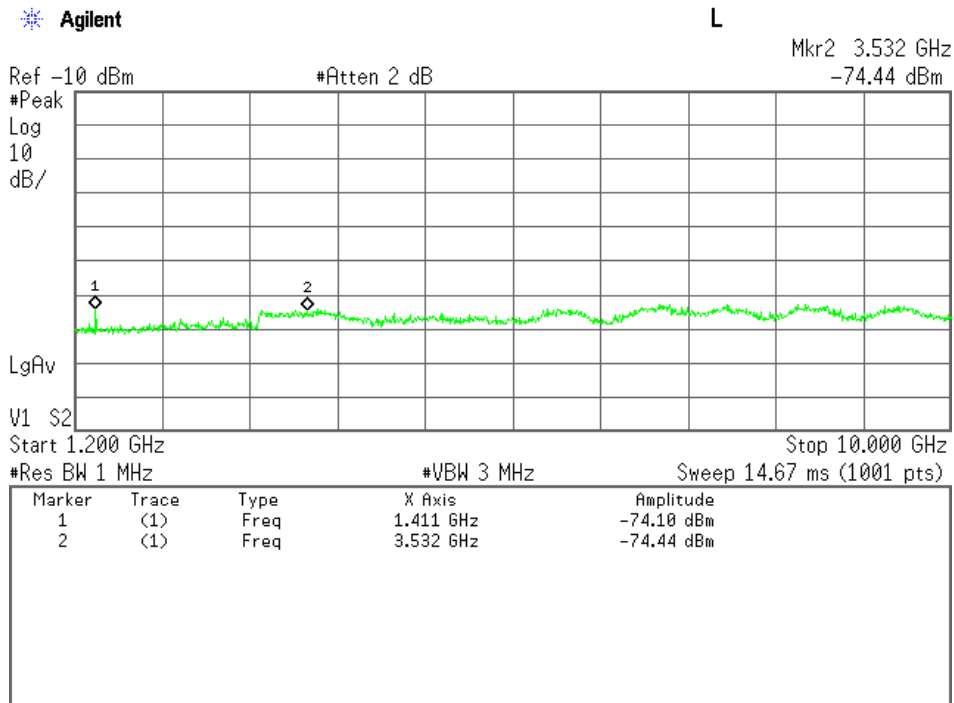

Middle Channel, Out-Of-Band Emissions (9 kHz – 150 kHz)

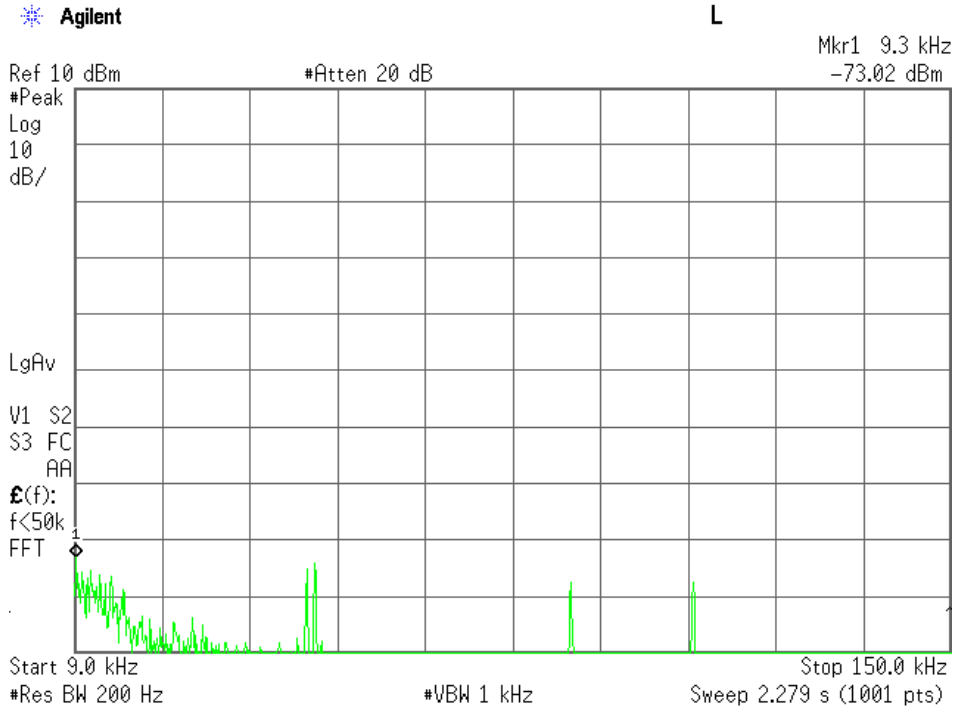

Middle Channel, Out-Of-Band Emissions (150 kHz – 30 MHz)

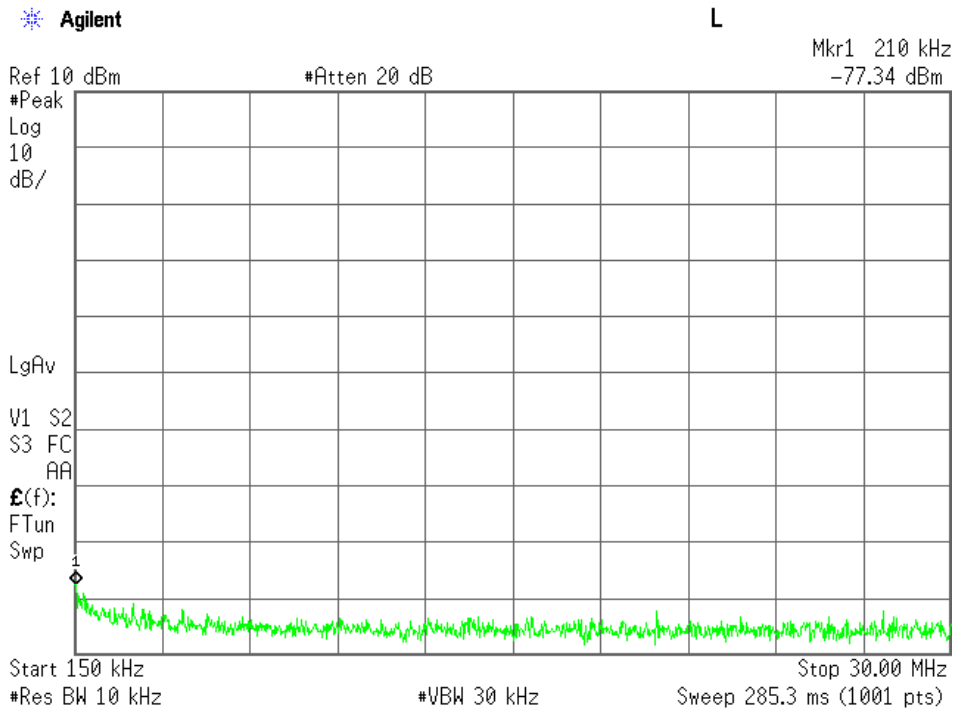

Middle Channel, Out-Of-Band Emissions (30 MHz – 1.2 GHz)

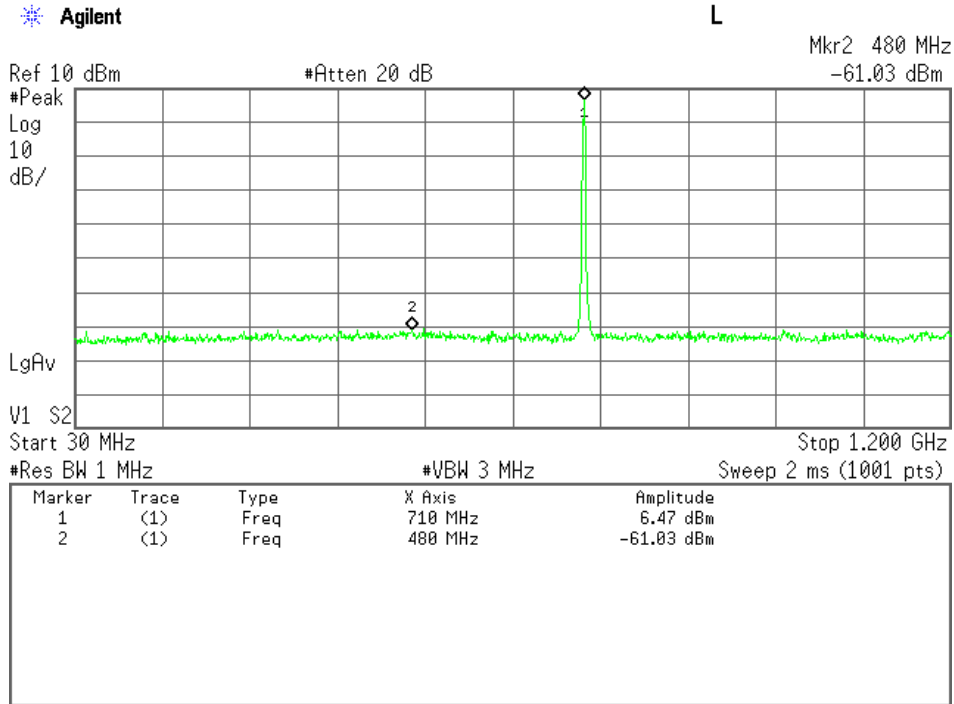

Middle Channel, Out-Of-Band Emissions (1.2 GHz – 10 GHz)

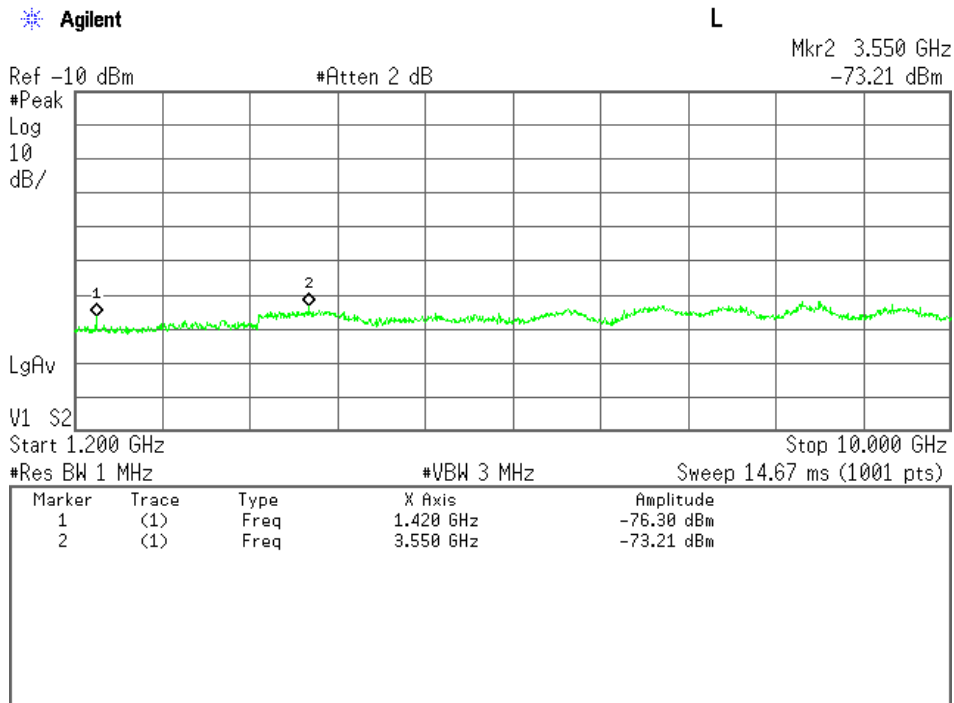

High Channel, Out-Of-Band Emissions (9 kHz – 150 kHz)

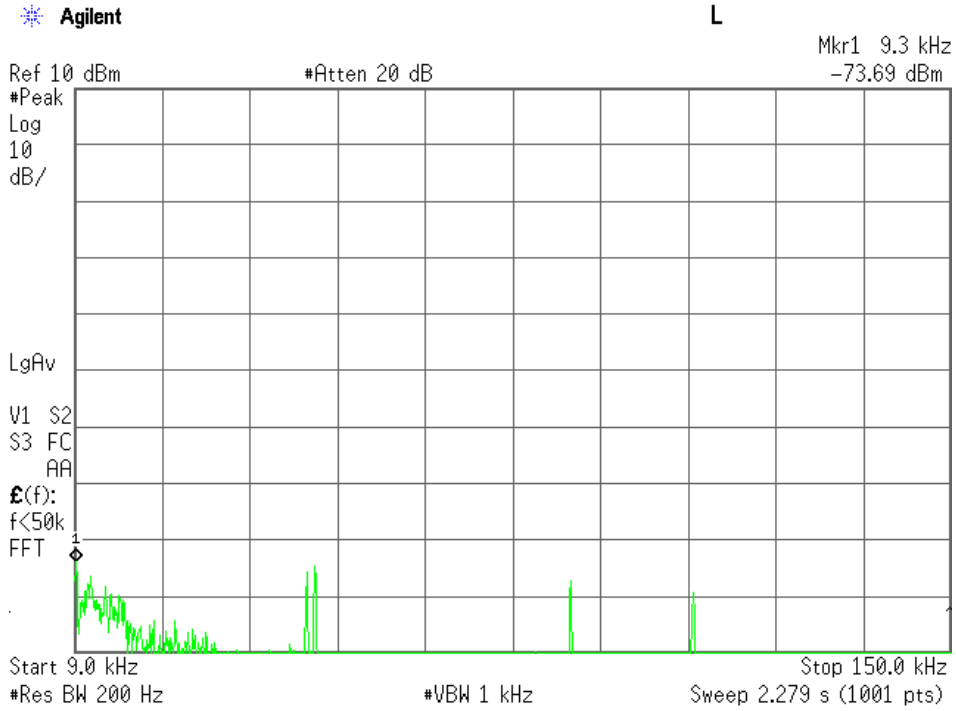

High Channel, Out-Of-Band Emissions (150 kHz – 30 MHz)

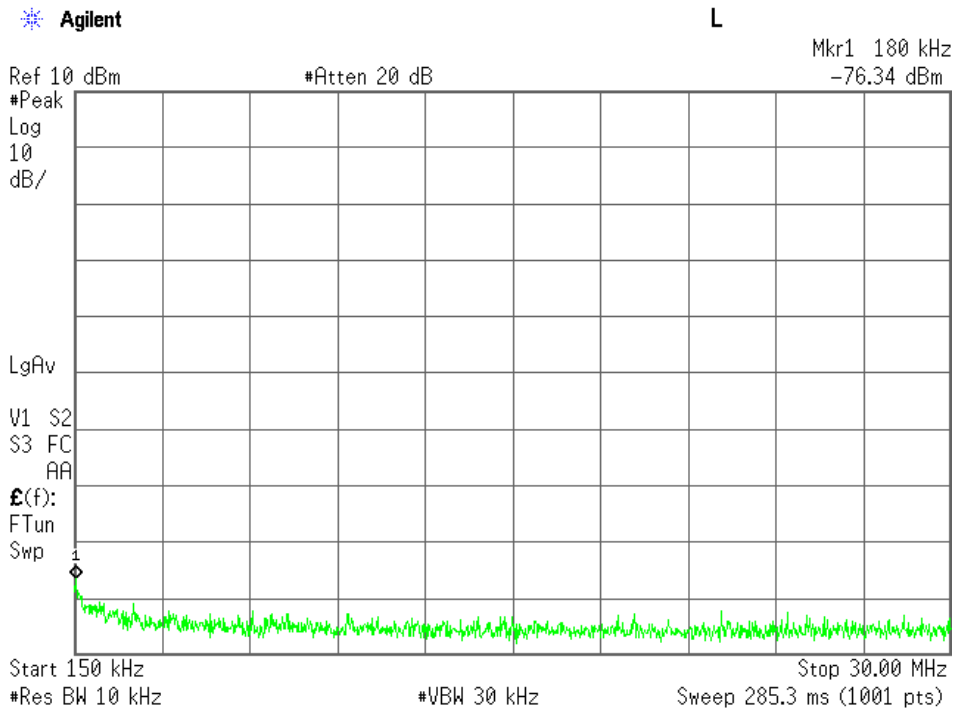

High Channel, Out-Of-Band Emissions (30 MHz – 1.2 GHz)

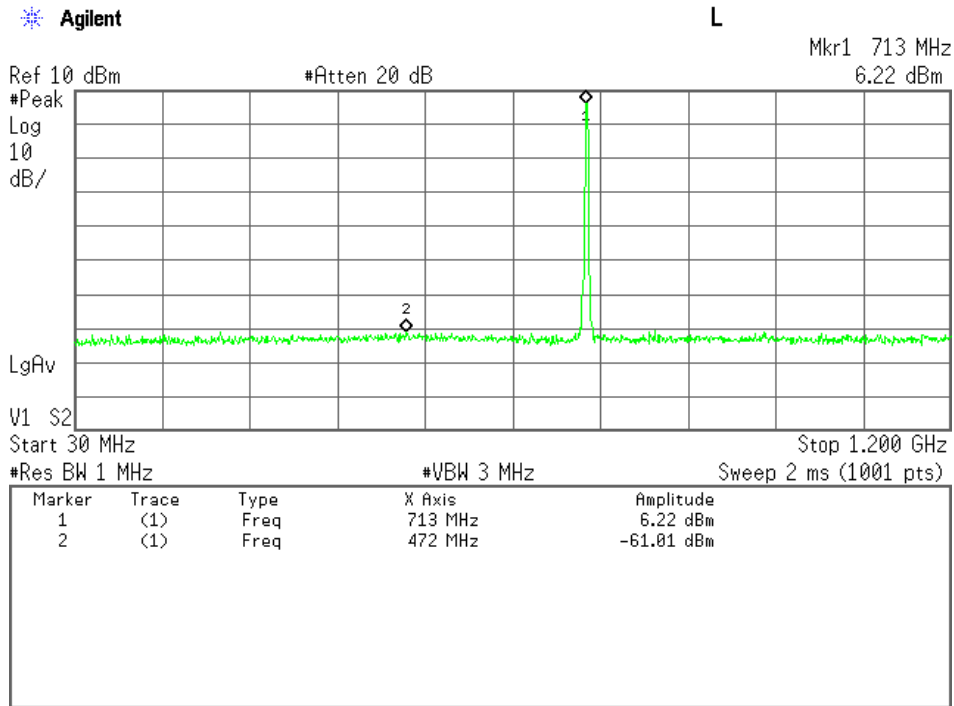

High Channel, Out-Of-Band Emissions (1.2 GHz – 10 GHz)

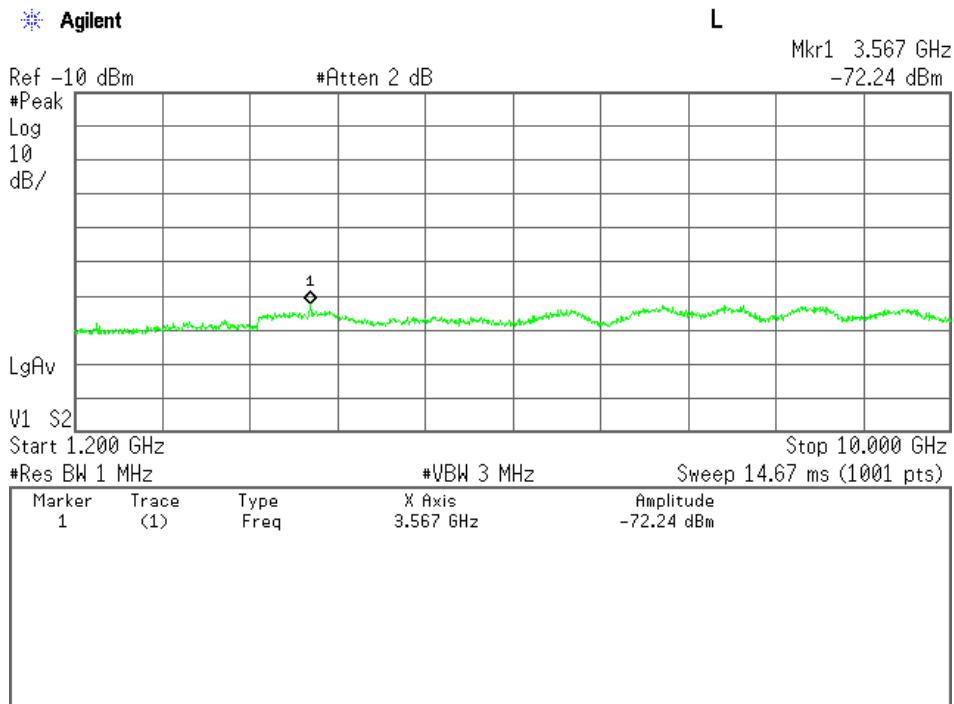

2) BW 10MHz(1RB)

(LTE 10MHz)

Test Date: March 16, 2015

Temp.: 22 °C, Humi: 45 %

Transmitting Frequency CH	[MHz]	Measured Frequency [MHz]	Corr. Factor [dB]	Meter Readings [dBm]	Limits [dBm]	Results [dBm]	Margin [dB]	Remarks
23780	709.000	1418.000	21.7	< -70.0	-13.0	< -48.3	> +35.3	C
		2127.000	21.0	< -70.0	-13.0	< -49.0	> +36.0	C
		2836.000	21.2	< -70.0	-13.0	< -48.8	> +35.8	C
		3545.000	21.3	< -70.0	-13.0	< -48.7	> +35.7	C
		4254.000	21.4	< -70.0	-13.0	< -48.6	> +35.6	C
		4963.000	21.4	< -70.0	-13.0	< -48.6	> +35.6	C
		5672.000	21.5	< -70.0	-13.0	< -48.5	> +35.5	C
		6381.000	21.6	< -70.0	-13.0	< -48.4	> +35.4	C
		7090.000	21.8	< -70.0	-13.0	< -48.2	> +35.2	C
23790	710.000	1420.000	21.7	< -70.0	-13.0	< -48.3	> +35.3	C
		2130.000	21.0	< -70.0	-13.0	< -49.0	> +36.0	C
		2840.000	21.2	< -70.0	-13.0	< -48.8	> +35.8	C
		3550.000	21.3	< -70.0	-13.0	< -48.7	> +35.7	C
		4260.000	21.4	< -70.0	-13.0	< -48.6	> +35.6	C
		4970.000	21.5	< -70.0	-13.0	< -48.5	> +35.5	C
		5680.000	21.5	< -70.0	-13.0	< -48.5	> +35.5	C
		6390.000	21.6	< -70.0	-13.0	< -48.4	> +35.4	C
		7100.000	21.8	< -70.0	-13.0	< -48.2	> +35.2	C
23800	711.000	1422.000	21.7	< -70.0	-13.0	< -48.3	> +35.3	C
		2133.000	21.0	< -70.0	-13.0	< -49.0	> +36.0	C
		2844.000	21.2	< -70.0	-13.0	< -48.8	> +35.8	C
		3555.000	21.3	< -70.0	-13.0	< -48.7	> +35.7	C
		4266.000	21.4	< -70.0	-13.0	< -48.6	> +35.6	C
		4977.000	21.5	< -70.0	-13.0	< -48.5	> +35.5	C
		5688.000	21.5	< -70.0	-13.0	< -48.5	> +35.5	C
		6399.000	21.6	< -70.0	-13.0	< -48.4	> +35.4	C
		7110.000	21.8	< -70.0	-13.0	< -48.2	> +35.2	C

Calculated result at 7090.0 MHz, as the worst point shown on underline:

Corr. Factor	=	21.8 dB
+) Meter Reading	=	<-70.0 dBm
Result	=	<-48.2 dBm

Minimum Margin: -13.0 - (<-48.2) =>35.2 (dB)

NOTES

1. The spectrum was checked from 9 kHz to 10 GHz.
2. Applied limits : -13.0 [dBm] = $10\log(TP[mW]) - (43 + 10\log(tp[W])) = 10\log(TP[mW]) - (43 + (10 \log(TP[mW]) - 30))$
 where, $tp[W] = TP[mW] / 1000$: Transmitter power at antenna terminal
3. The correction factor is shown as follows:
 Corr. Factor [dB] = Cable Loss + 10dB Pad Att. [dB] (9 kHz - 2 GHz)
 Corr. Factor [dB] = Cable Loss + 10dB Pad Att. + High Pass Filter Loss (D-96) [dB] (over 2 GHz)
4. The symbol of "<" means "or less".
5. The symbol of ">" means "more than".
6. Setting of measuring instrument(s) :

	Detector Function	RES B.W.	V.B.W.	Sweep Time
A	Peak	200 Hz	1 kHz	AUTO
B	Peak	10 kHz	30 kHz	AUTO
C	Peak	1 MHz	3 MHz	AUTO

Low Channel, Out-Of-Band Emissions (9 kHz – 150 kHz)

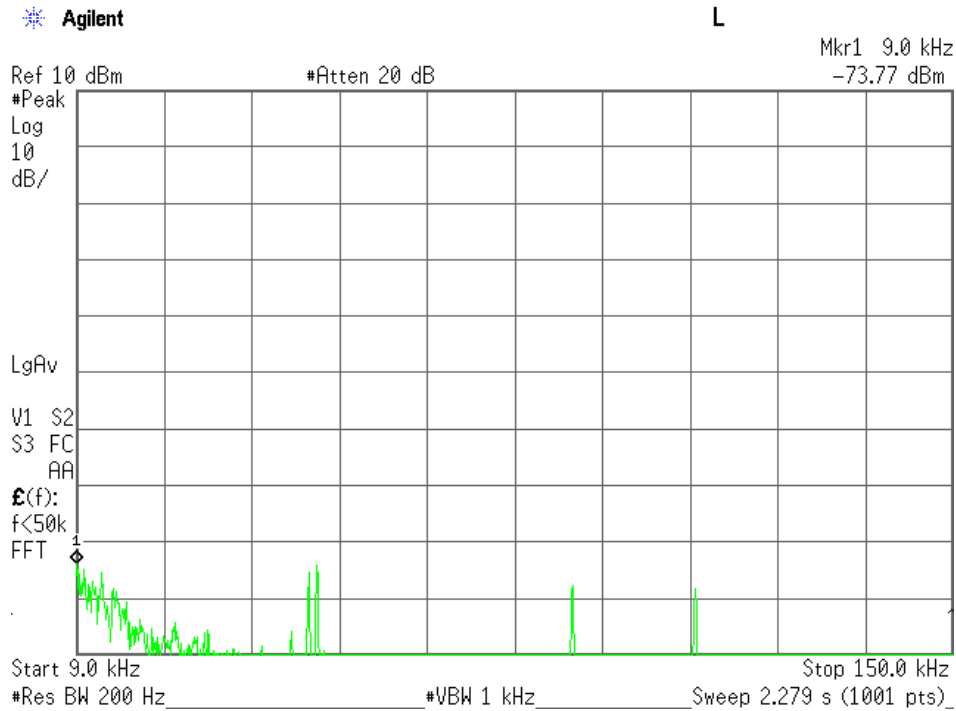

Low Channel, Out-Of-Band Emissions (150 kHz – 30 MHz)

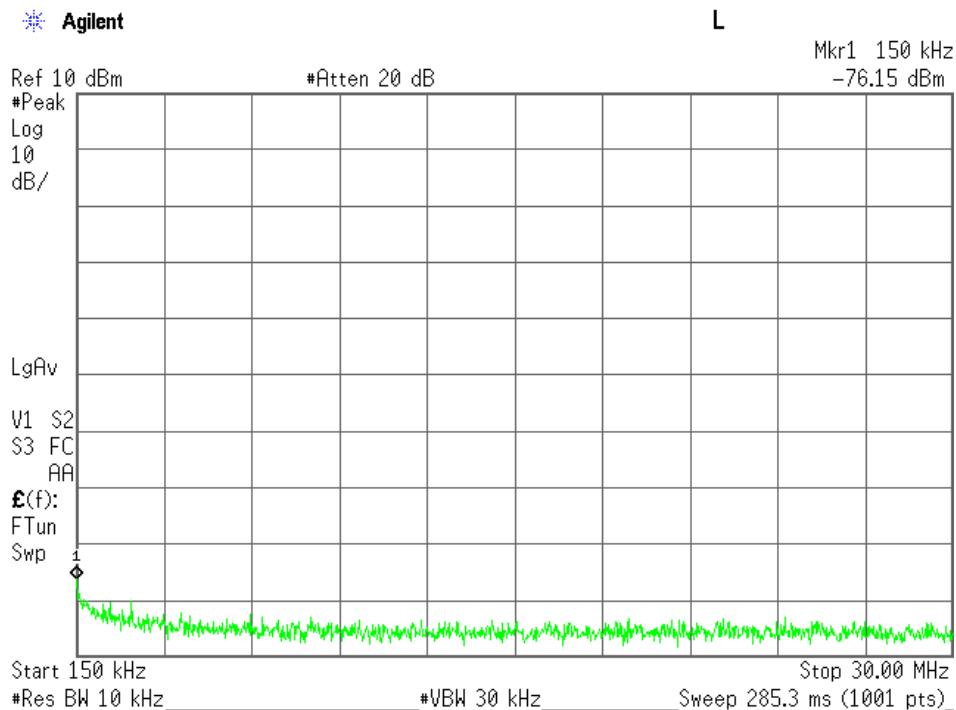

Low Channel, Out-Of-Band Emissions (30 MHz – 1.2 GHz)

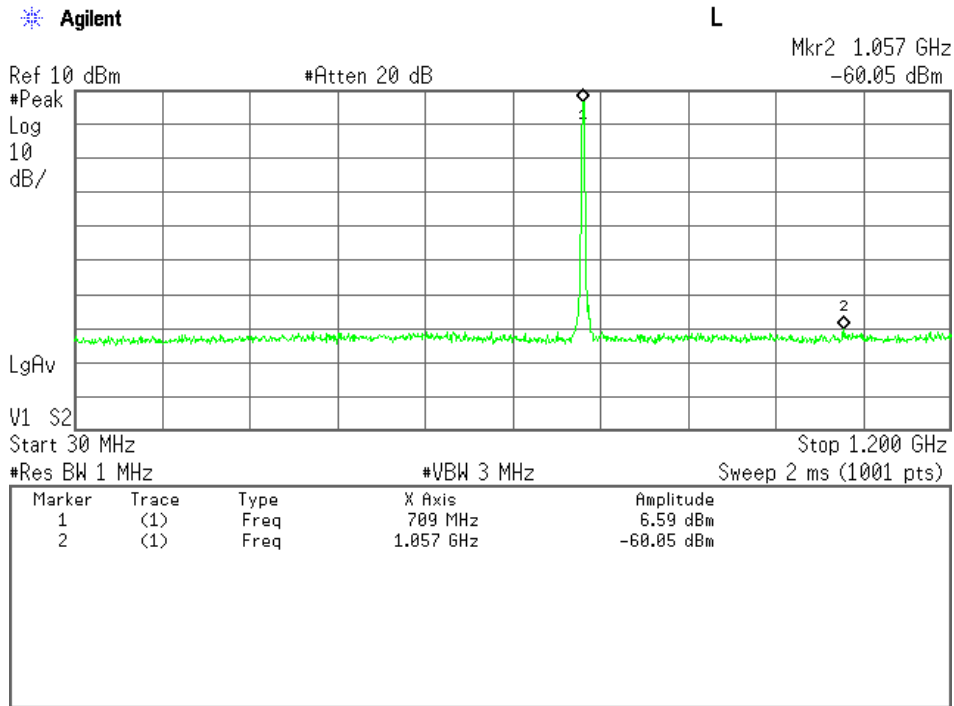

Low Channel, Out-Of-Band Emissions (1.2 GHz – 10 GHz)

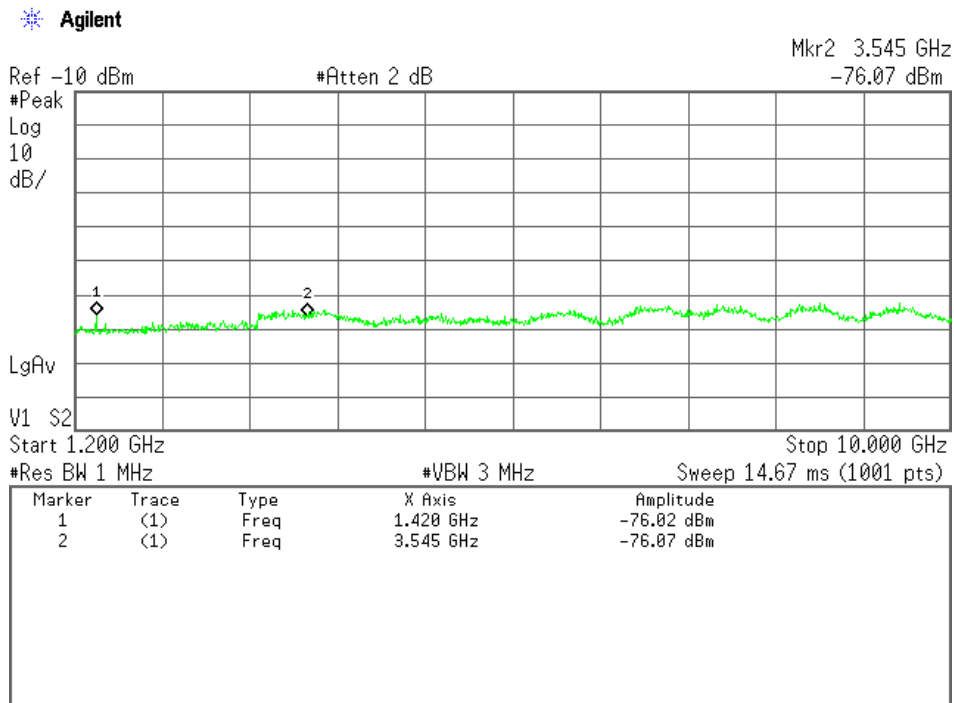

Middle Channel, Out-Of-Band Emissions (9 kHz – 150 kHz)

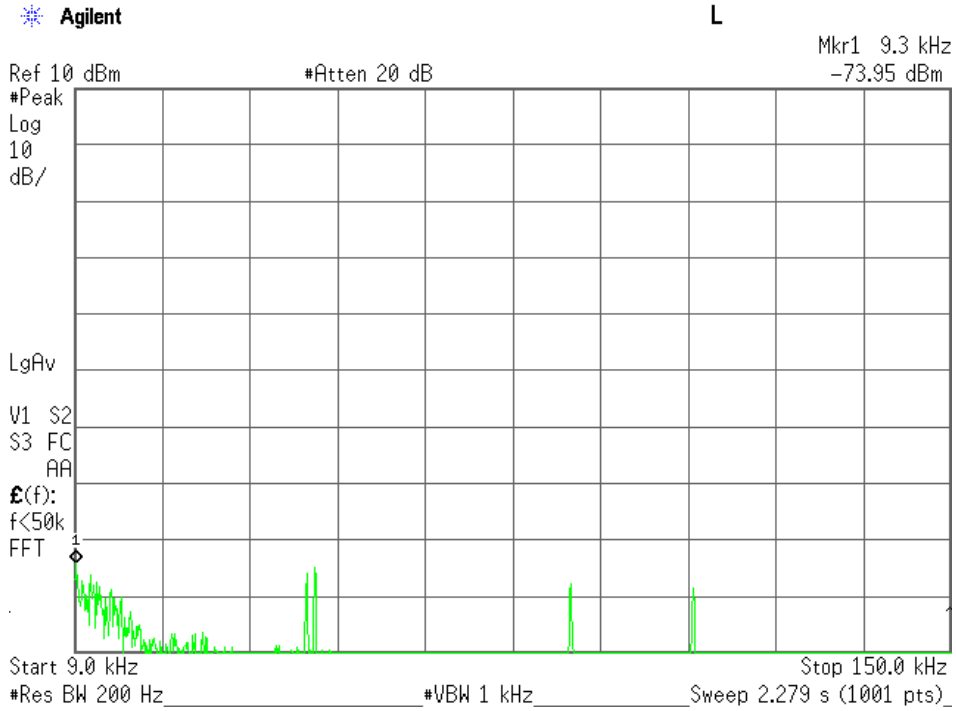

Middle Channel, Out-Of-Band Emissions (150 kHz – 30 MHz)

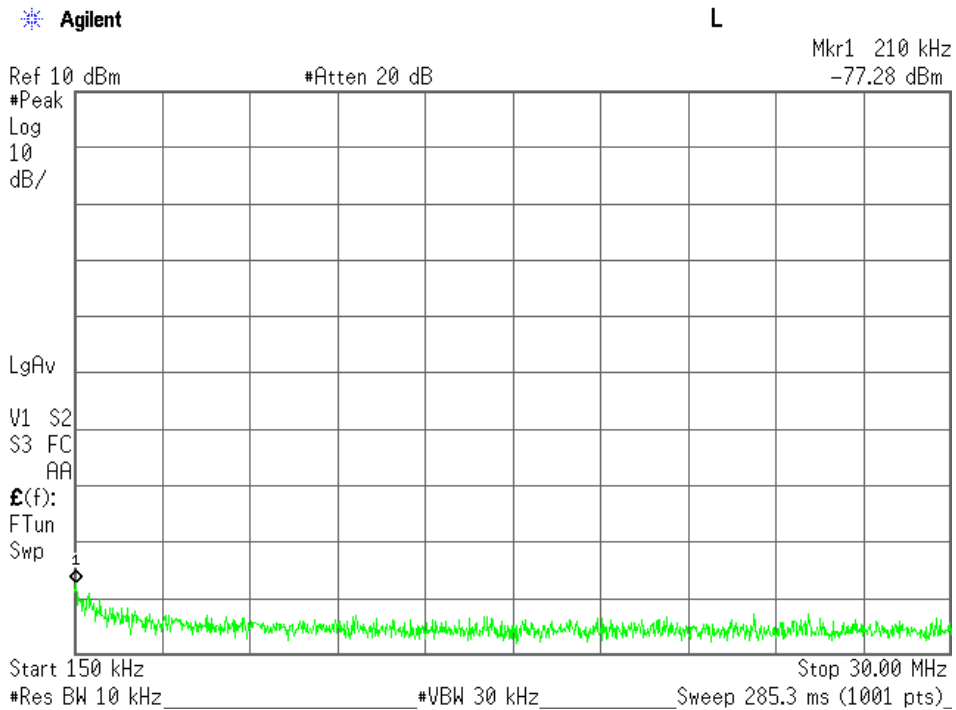

Middle Channel, Out-Of-Band Emissions (30 MHz – 1.2 GHz)

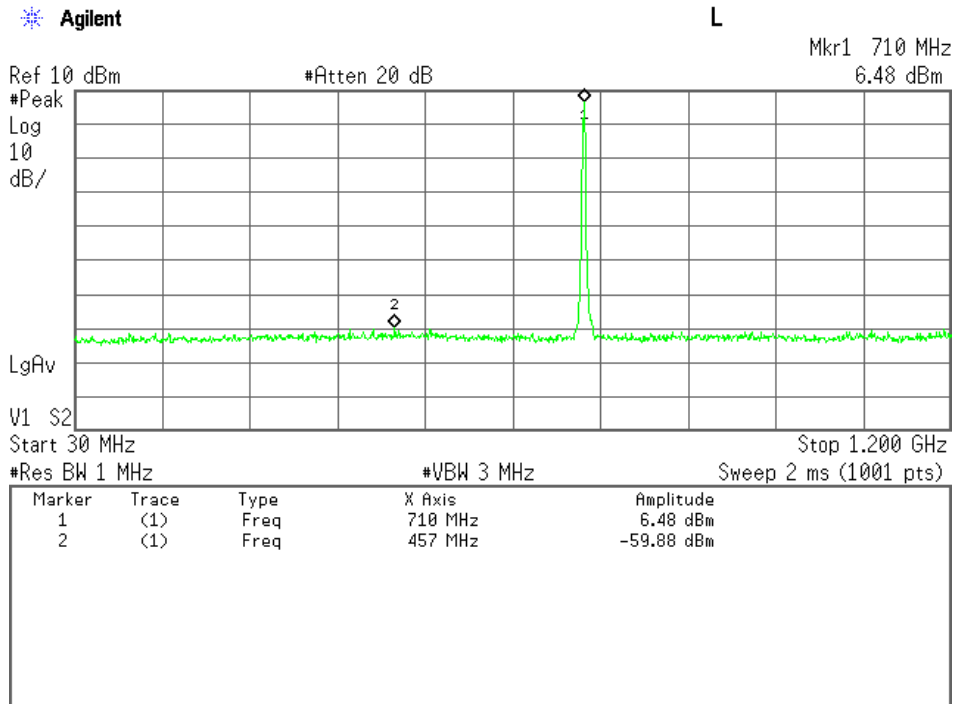

Middle Channel, Out-Of-Band Emissions (1.2 GHz – 10 GHz)

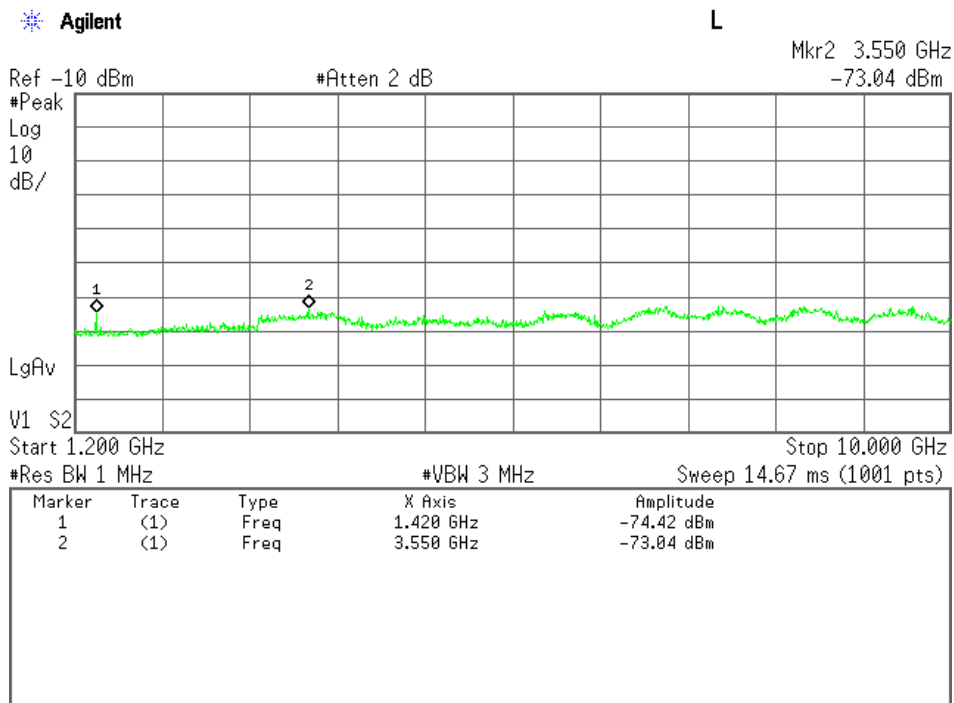

High Channel, Out-Of-Band Emissions (9 kHz – 150 kHz)

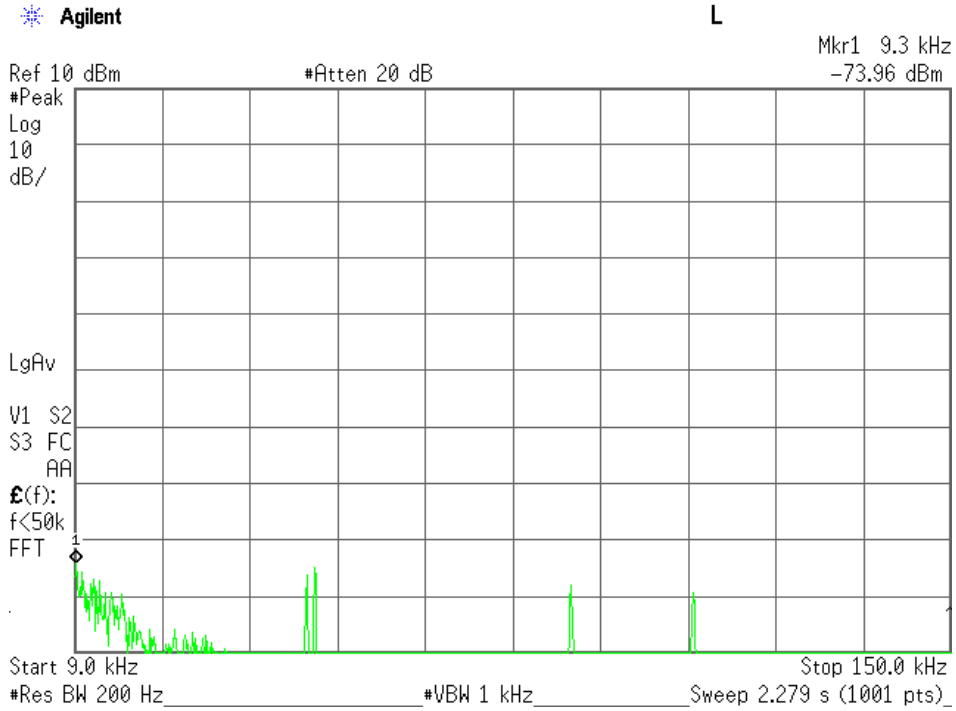

High Channel, Out-Of-Band Emissions (150 kHz – 30 MHz)

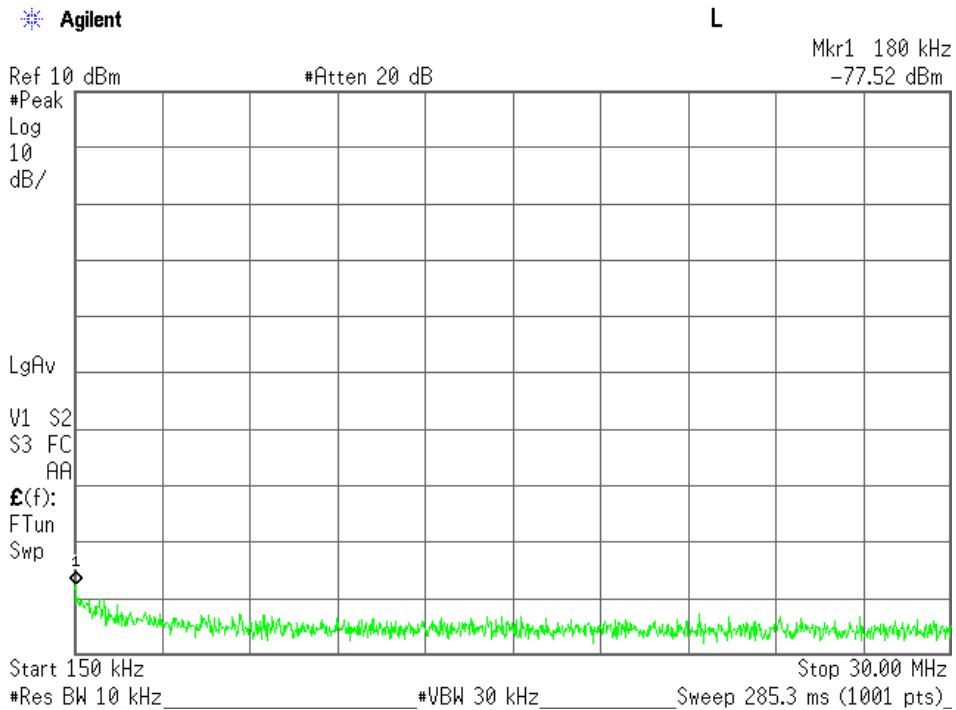

High Channel, Out-Of-Band Emissions (30 MHz – 1.2 GHz)

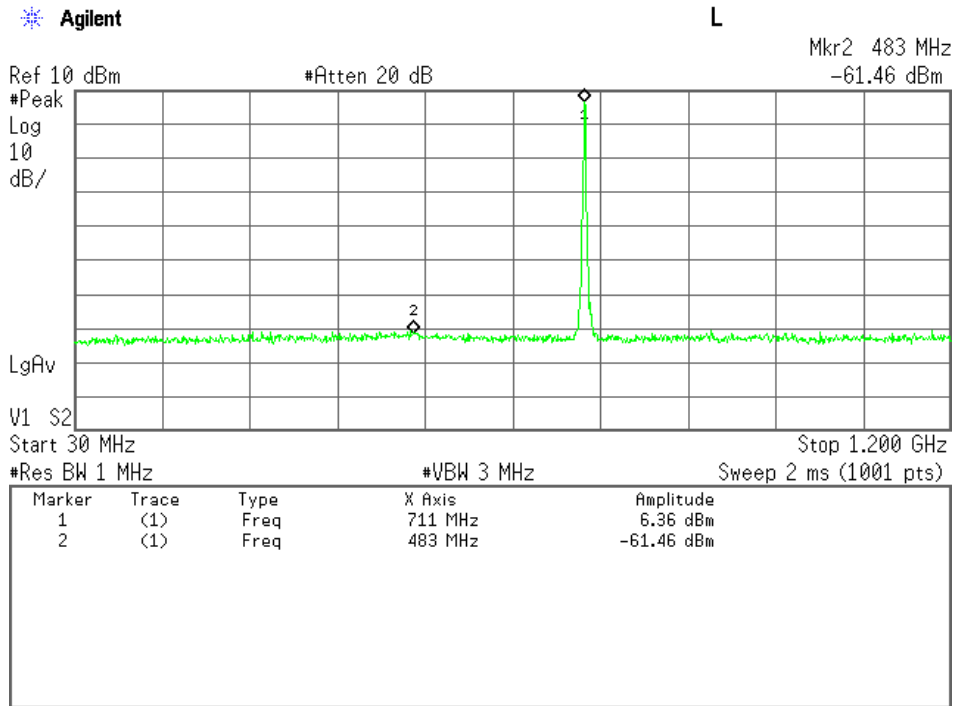

High Channel, Out-Of-Band Emissions (1.2 GHz – 10 GHz)

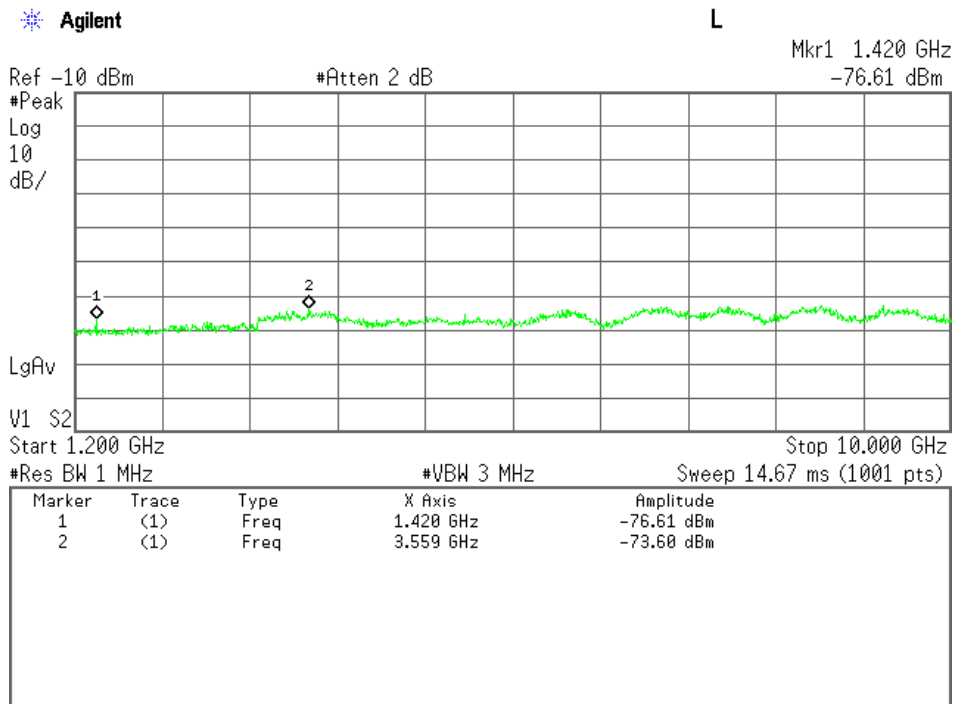

b) Sub Antenna

1) BW 5MHz(1RB)

(LTE 5MHz)

Test Date: March 24, 2015
Temp.: 22 °C, Humi: 30 %

Transmitting Frequency CH	[MHz]	Measured Frequency [MHz]	Corr. Factor [dB]	Meter Readings [dBm]	Limits [dBm]	Results [dBm]	Margin [dB]	Remarks
23755	706.500	1413.000	21.7	< -70.0	-13.0	< -48.3	> +35.3	C
		2119.500	21.0	< -70.0	-13.0	< -49.0	> +36.0	C
		2826.000	21.2	< -70.0	-13.0	< -48.8	> +35.8	C
		3532.500	21.3	< -70.0	-13.0	< -48.7	> +35.7	C
		4239.000	21.4	< -70.0	-13.0	< -48.6	> +35.6	C
		4945.500	21.4	< -70.0	-13.0	< -48.6	> +35.6	C
		5652.000	21.5	< -70.0	-13.0	< -48.5	> +35.5	C
		6358.500	21.6	< -70.0	-13.0	< -48.4	> +35.4	C
		7065.000	21.7	< -70.0	-13.0	< -48.3	> +35.3	C
23790	710.000	1420.000	21.7	< -70.0	-13.0	< -48.3	> +35.3	C
		2130.000	21.0	< -70.0	-13.0	< -49.0	> +36.0	C
		2840.000	21.2	< -70.0	-13.0	< -48.8	> +35.8	C
		3550.000	21.3	< -70.0	-13.0	< -48.7	> +35.7	C
		4260.000	21.4	< -70.0	-13.0	< -48.6	> +35.6	C
		4970.000	21.5	< -70.0	-13.0	< -48.5	> +35.5	C
		5680.000	21.5	< -70.0	-13.0	< -48.5	> +35.5	C
		6390.000	21.6	< -70.0	-13.0	< -48.4	> +35.4	C
		7100.000	21.8	< -70.0	-13.0	< -48.2	> +35.2	C
23825	713.500	1427.000	21.7	< -70.0	-13.0	< -48.3	> +35.3	C
		2140.500	21.0	< -70.0	-13.0	< -49.0	> +36.0	C
		2854.000	21.2	< -70.0	-13.0	< -48.8	> +35.8	C
		3567.500	21.3	< -70.0	-13.0	< -48.7	> +35.7	C
		4281.000	21.4	< -70.0	-13.0	< -48.6	> +35.6	C
		4994.500	21.5	< -70.0	-13.0	< -48.5	> +35.5	C
		5708.000	21.5	< -70.0	-13.0	< -48.5	> +35.5	C
		6421.500	21.6	< -70.0	-13.0	< -48.4	> +35.4	C
		7135.000	21.8	< -70.0	-13.0	< -48.2	> +35.2	C

Calculated result at 7100.0 MHz, as the worst point shown on underline:

Corr. Factor	=	21.8 dB
+) Meter Reading	=	<-70.0 dBm
Result	=	<-48.2 dBm

Minimum Margin: -13.0 - (<-48.2) =>35.2 (dB)

NOTES

- The spectrum was checked from 9 kHz to 10 GHz.
- Applied limits : -13.0 [dBm] = $10\log(TP[mW]) - (43 + 10\log(tp[W])) = 10\log(TP[mW]) - (43 + (10 \log(TP[mW]) - 30))$
where, $tp[W] = TP[mW] / 1000$: Transmitter power at antenna terminal
- The correction factor is shown as follows:
Corr. Factor [dB] = Cable Loss + 10dB Pad Att. [dB] (9 kHz - 2 GHz)
Corr. Factor [dB] = Cable Loss + 10dB Pad Att. + High Pass Filter Loss (D-96) [dB] (over 2 GHz)
- The symbol of "<" means "or less".
- The symbol of ">" means "more than".
- Setting of measuring instrument(s) :

	Detector Function	RES B.W.	V.B.W.	Sweep Time
A	Peak	200 Hz	1 kHz	AUTO
B	Peak	10 kHz	30 kHz	AUTO
C	Peak	1 MHz	3 MHz	AUTO

Low Channel, Out-Of-Band Emissions (9 kHz – 150 kHz)

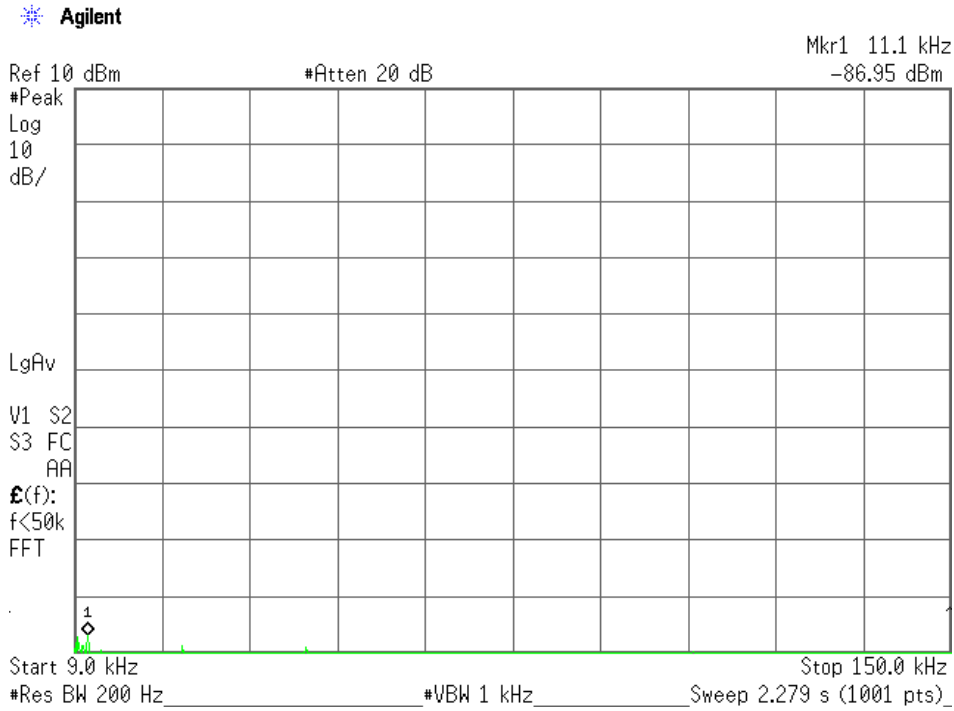

Low Channel, Out-Of-Band Emissions (150 kHz – 30 MHz)

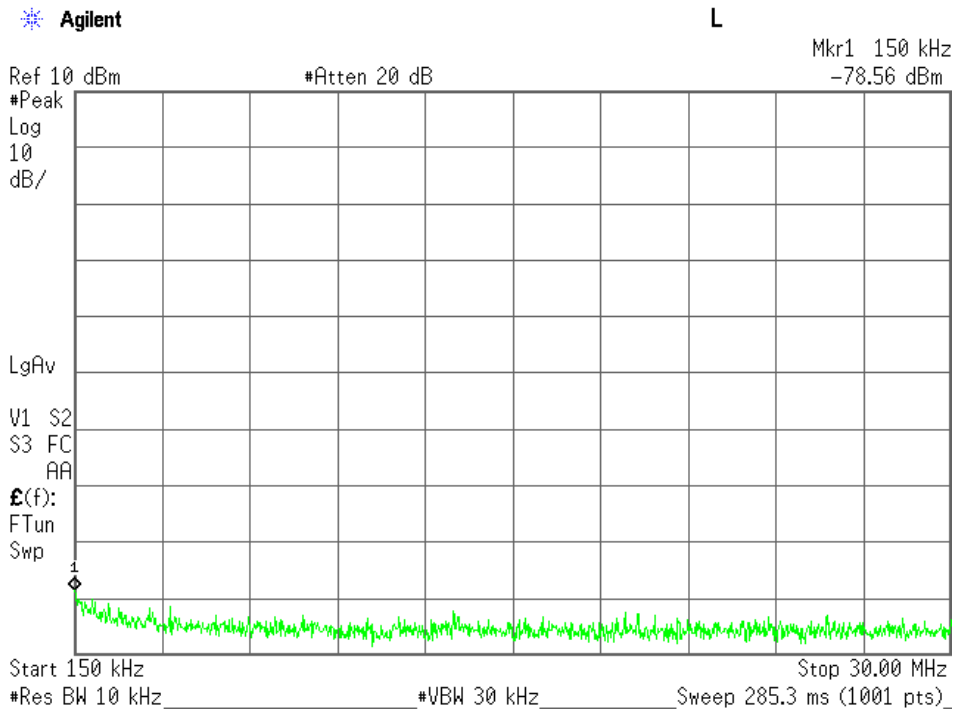

Low Channel, Out-Of-Band Emissions (30 MHz – 1.2 GHz)

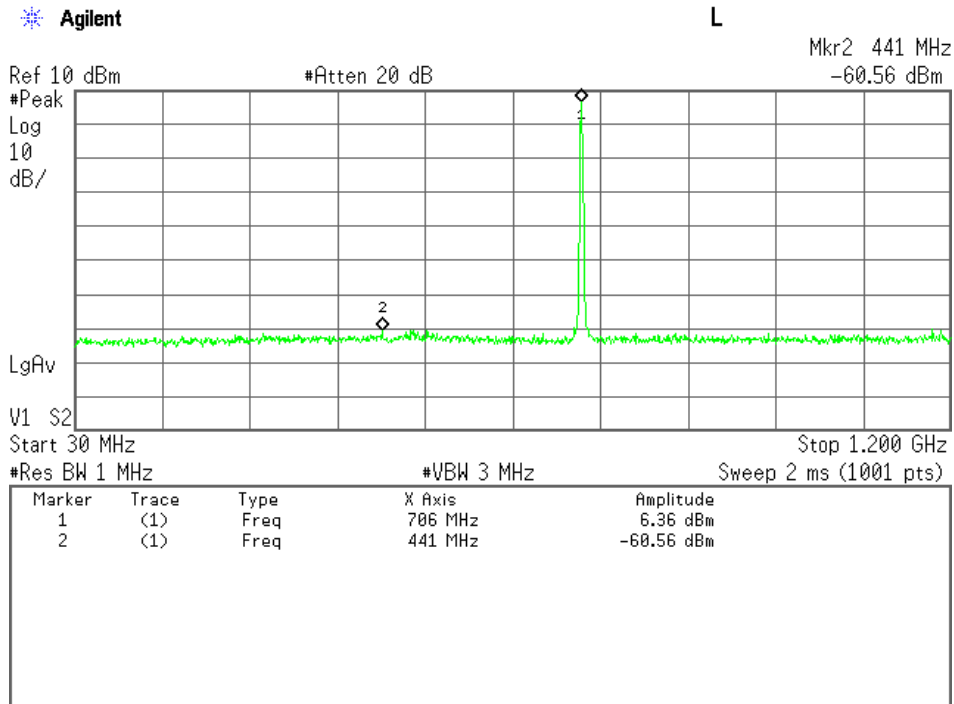

Low Channel, Out-Of-Band Emissions (1.2 GHz – 10 GHz)

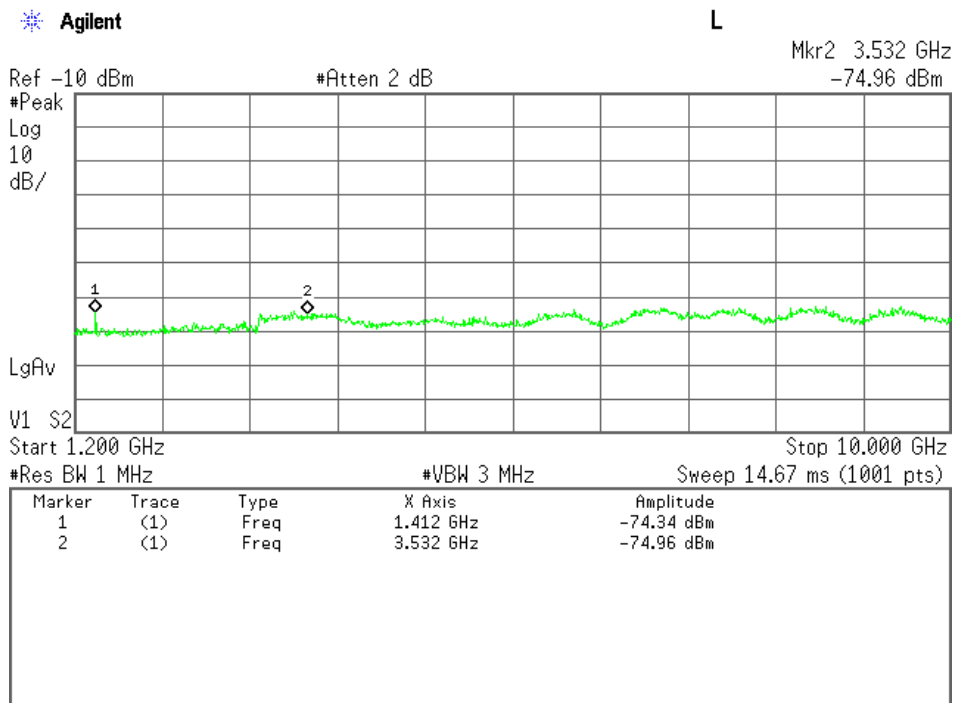

Middle Channel, Out-Of-Band Emissions (9 kHz – 150 kHz)

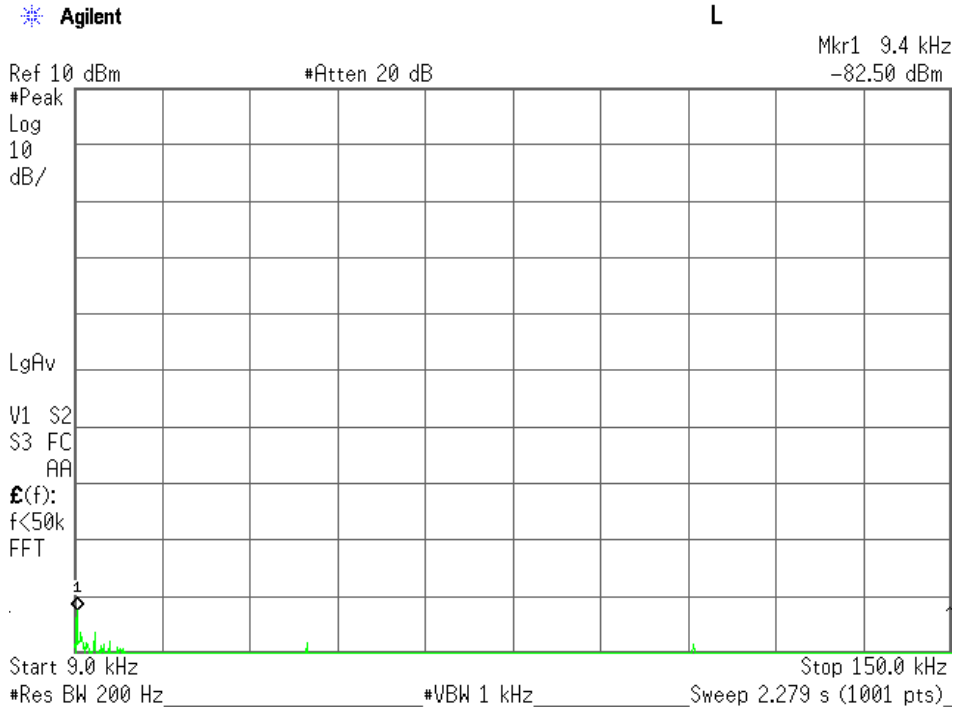

Middle Channel, Out-Of-Band Emissions (150 kHz – 30 MHz)

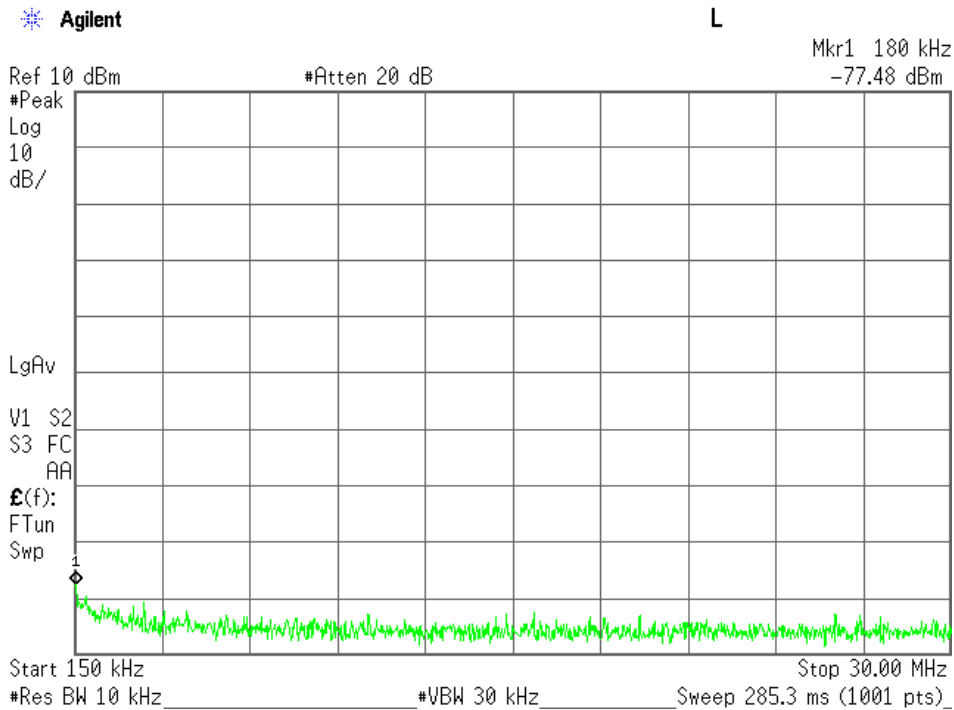

Middle Channel, Out-Of-Band Emissions (30 MHz – 1.2 GHz)

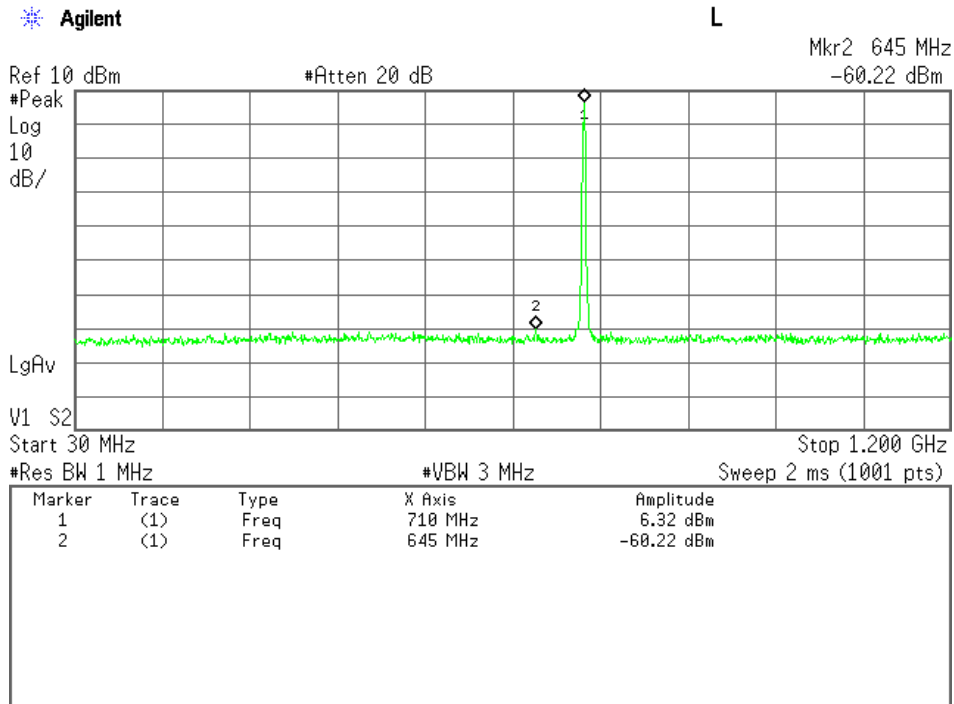

Middle Channel, Out-Of-Band Emissions (1.2 GHz – 10 GHz)

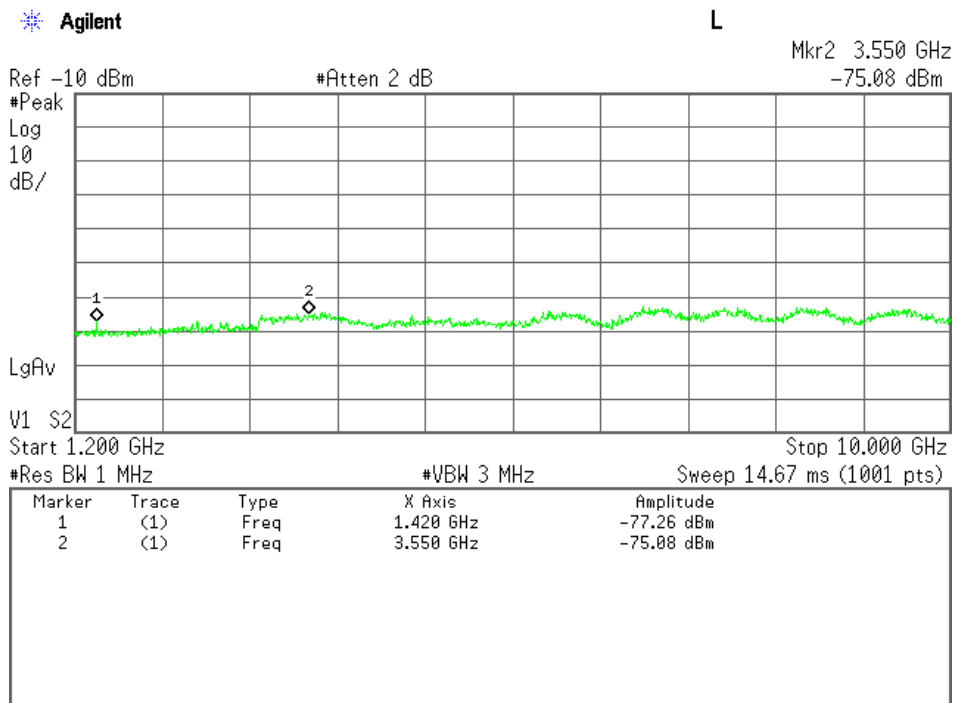

High Channel, Out-Of-Band Emissions (9 kHz – 150 kHz)

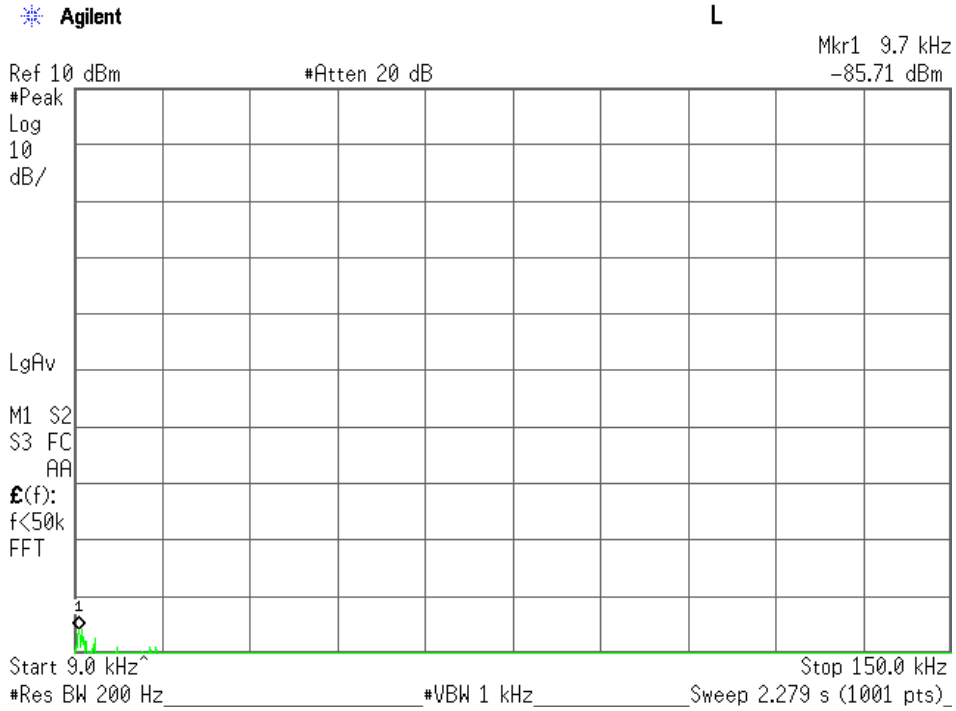

High Channel, Out-Of-Band Emissions (150 kHz – 30 MHz)

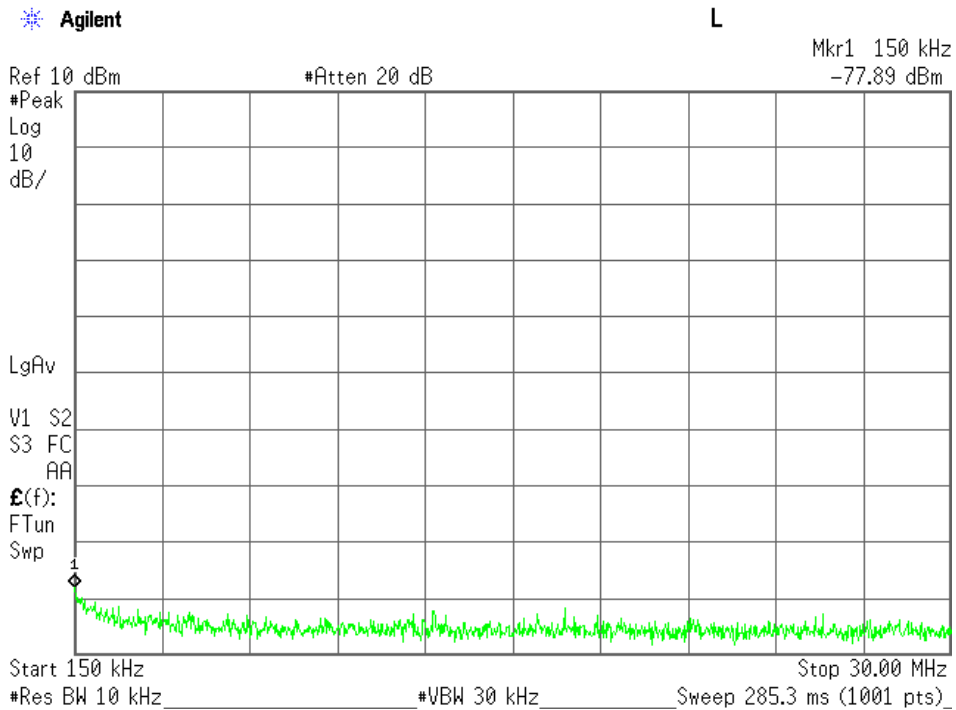

High Channel, Out-Of-Band Emissions (30 MHz – 1.2 GHz)

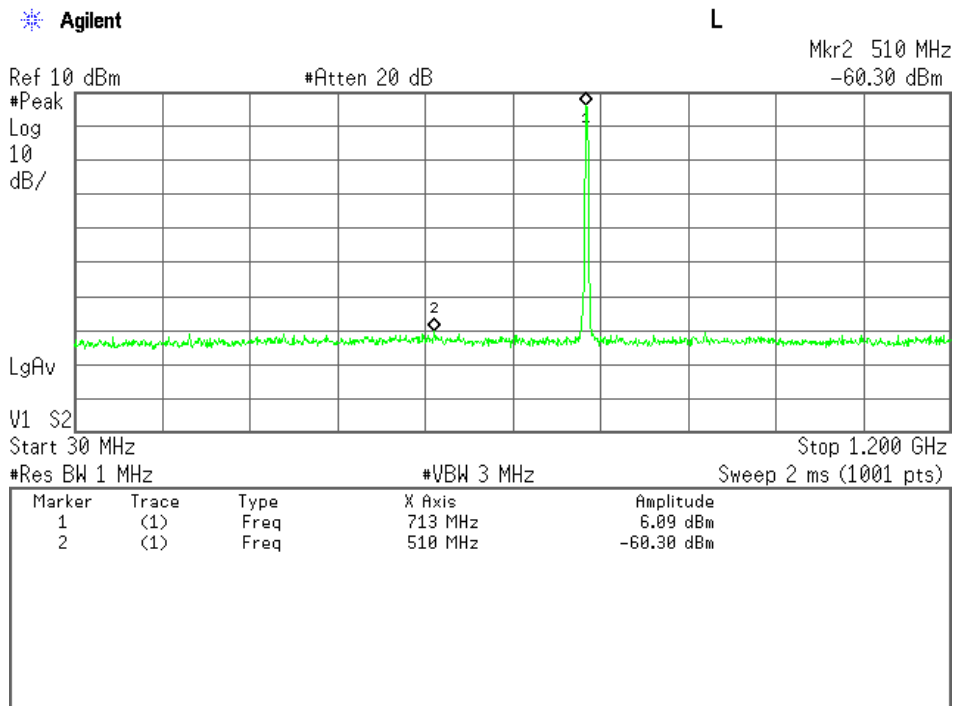

High Channel, Out-Of-Band Emissions (1.2 GHz – 10 GHz)

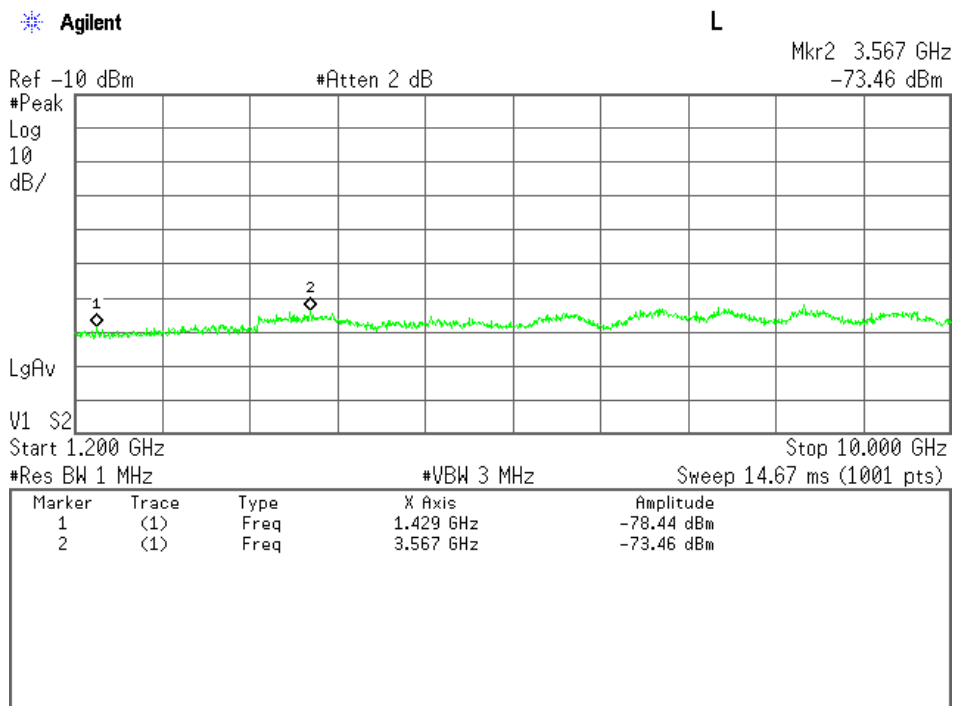

2) BW 10MHz(1RB)

(LTE 10MHz)

Test Date: March 24, 2015

Temp.: 22 °C, Humi: 30 %

Transmitting Frequency CH	[MHz]	Measured Frequency [MHz]	Corr. Factor [dB]	Meter Readings [dBm]	Limits [dBm]	Results [dBm]	Margin [dB]	Remarks
23780	709.000	1418.000	21.7	< -70.0	-13.0	< -48.3	> +35.3	C
		2127.000	21.0	< -70.0	-13.0	< -49.0	> +36.0	C
		2836.000	21.2	< -70.0	-13.0	< -48.8	> +35.8	C
		3545.000	21.3	< -70.0	-13.0	< -48.7	> +35.7	C
		4254.000	21.4	< -70.0	-13.0	< -48.6	> +35.6	C
		4963.000	21.4	< -70.0	-13.0	< -48.6	> +35.6	C
		5672.000	21.5	< -70.0	-13.0	< -48.5	> +35.5	C
		6381.000	21.6	< -70.0	-13.0	< -48.4	> +35.4	C
		7090.000	21.8	< -70.0	-13.0	< -48.2	> +35.2	C
23790	710.000	1420.000	21.7	< -70.0	-13.0	< -48.3	> +35.3	C
		2130.000	21.0	< -70.0	-13.0	< -49.0	> +36.0	C
		2840.000	21.2	< -70.0	-13.0	< -48.8	> +35.8	C
		3550.000	21.3	< -70.0	-13.0	< -48.7	> +35.7	C
		4260.000	21.4	< -70.0	-13.0	< -48.6	> +35.6	C
		4970.000	21.5	< -70.0	-13.0	< -48.5	> +35.5	C
		5680.000	21.5	< -70.0	-13.0	< -48.5	> +35.5	C
		6390.000	21.6	< -70.0	-13.0	< -48.4	> +35.4	C
		7100.000	21.8	< -70.0	-13.0	< -48.2	> +35.2	C
23800	711.000	1422.000	21.7	< -70.0	-13.0	< -48.3	> +35.3	C
		2133.000	21.0	< -70.0	-13.0	< -49.0	> +36.0	C
		2844.000	21.2	< -70.0	-13.0	< -48.8	> +35.8	C
		3555.000	21.3	< -70.0	-13.0	< -48.7	> +35.7	C
		4266.000	21.4	< -70.0	-13.0	< -48.6	> +35.6	C
		4977.000	21.5	< -70.0	-13.0	< -48.5	> +35.5	C
		5688.000	21.5	< -70.0	-13.0	< -48.5	> +35.5	C
		6399.000	21.6	< -70.0	-13.0	< -48.4	> +35.4	C
		7110.000	21.8	< -70.0	-13.0	< -48.2	> +35.2	C

Calculated result at 7090.0 MHz, as the worst point shown on underline:

Corr. Factor	=	21.8 dB
+) Meter Reading	=	<-70.0 dBm
Result	=	<-48.2 dBm

Minimum Margin: -13.0 - (<-48.2) =>35.2 (dB)

NOTES

1. The spectrum was checked from 9 kHz to 10 GHz.
2. Applied limits : -13.0 [dBm] = $10\log(TP[mW]) - (43 + 10\log(tp[W])) = 10\log(TP[mW]) - (43 + (10 \log(TP[mW]) - 30))$
 where, $tp[W] = TP[mW] / 1000$: Transmitter power at antenna terminal
3. The correction factor is shown as follows:
 Corr. Factor [dB] = Cable Loss + 10dB Pad Att. [dB] (9 kHz - 2 GHz)
 Corr. Factor [dB] = Cable Loss + 10dB Pad Att. + High Pass Filter Loss (D-96) [dB] (over 2 GHz)
4. The symbol of "<" means "or less".
5. The symbol of ">" means "more than".
6. Setting of measuring instrument(s) :

	Detector Function	RES B.W.	V.B.W.	Sweep Time
A	Peak	200 Hz	1 kHz	AUTO
B	Peak	10 kHz	30 kHz	AUTO
C	Peak	1 MHz	3 MHz	AUTO

Low Channel, Out-Of-Band Emissions (9 kHz – 150 kHz)

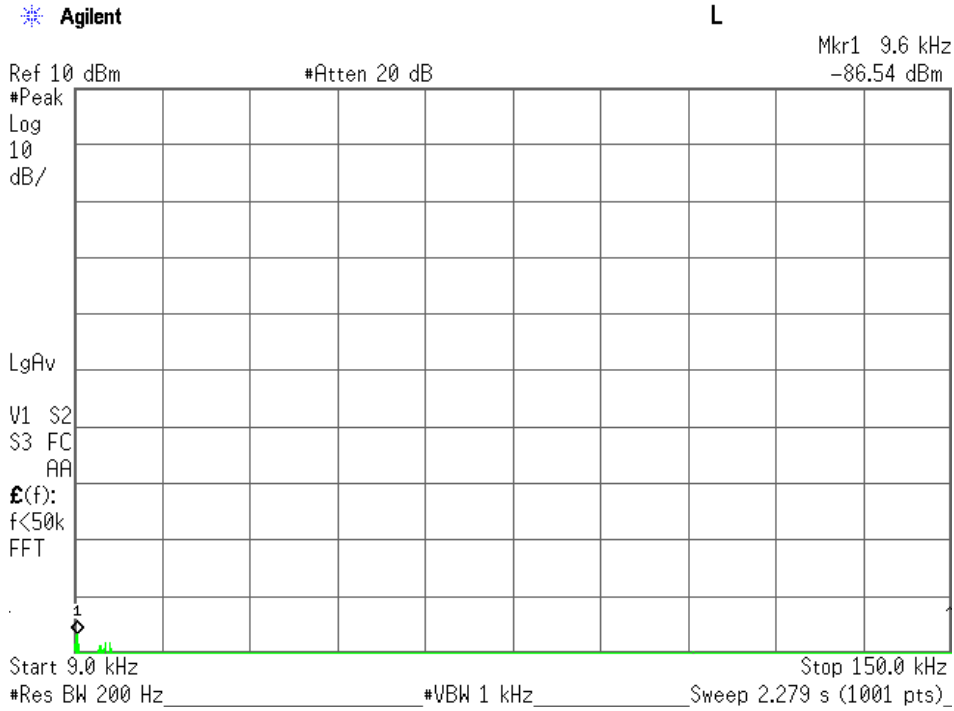

Low Channel, Out-Of-Band Emissions (150 kHz – 30 MHz)

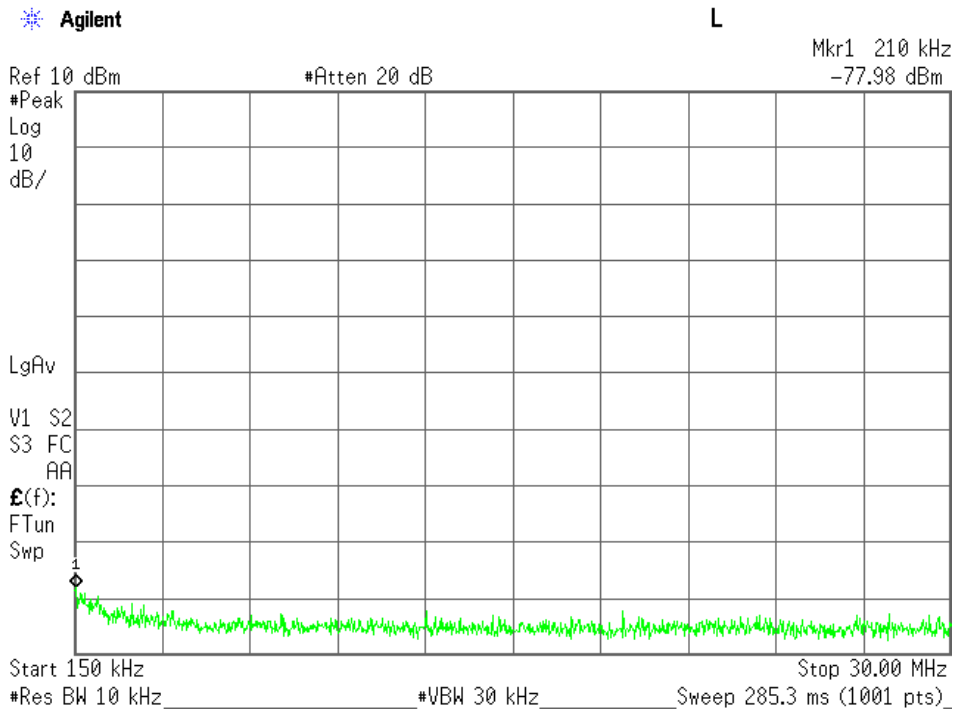

Low Channel, Out-Of-Band Emissions (30 MHz – 1.2 GHz)

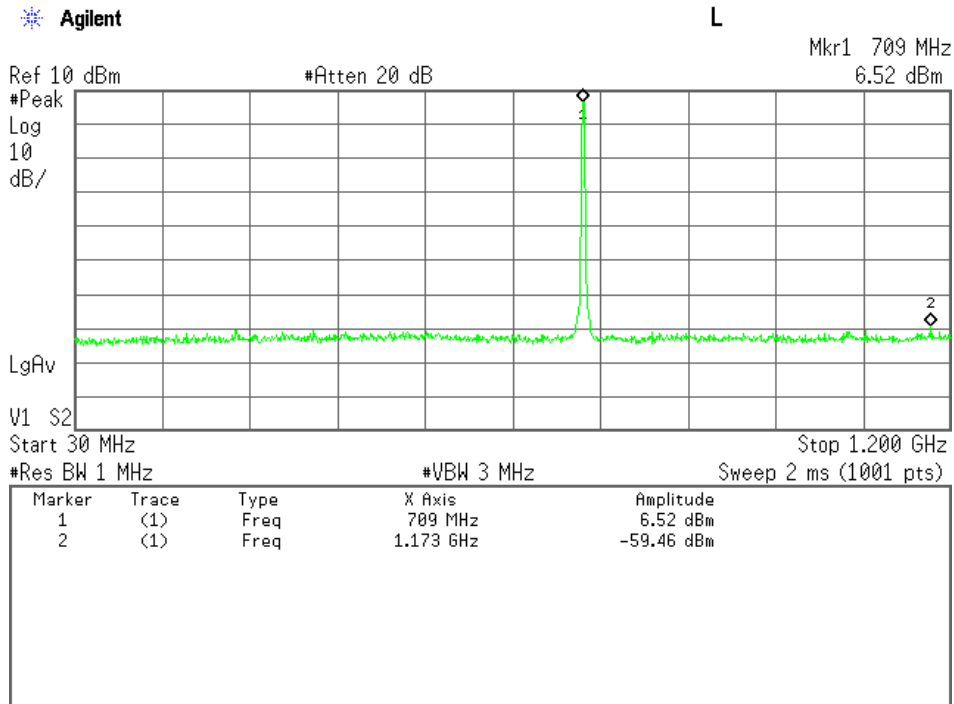

Low Channel, Out-Of-Band Emissions (1.2 GHz – 10 GHz)

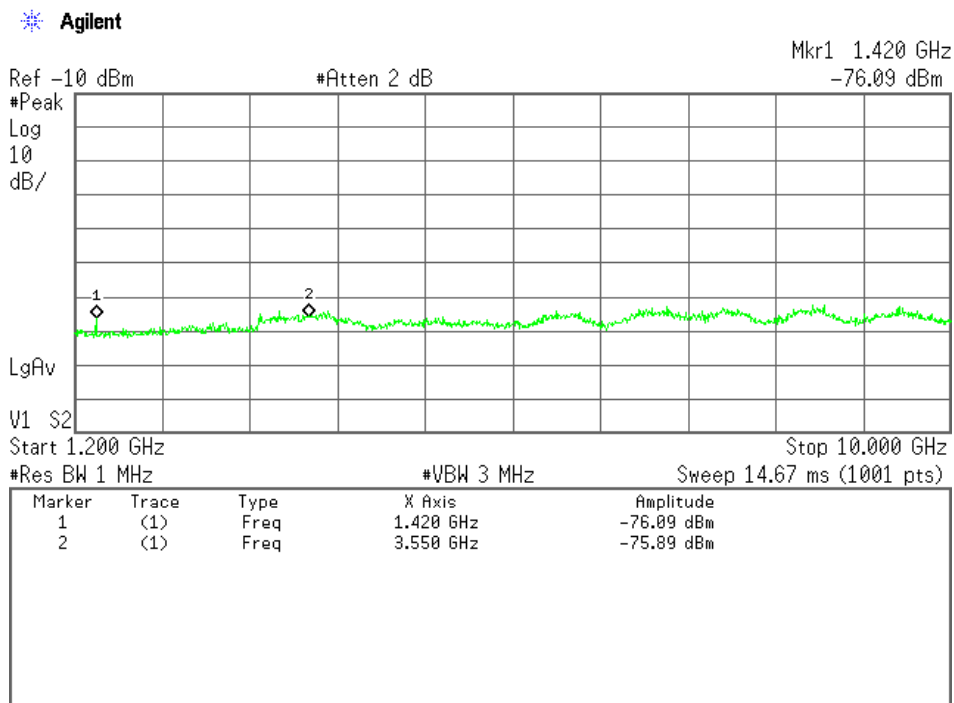

Middle Channel, Out-Of-Band Emissions (9 kHz – 150 kHz)

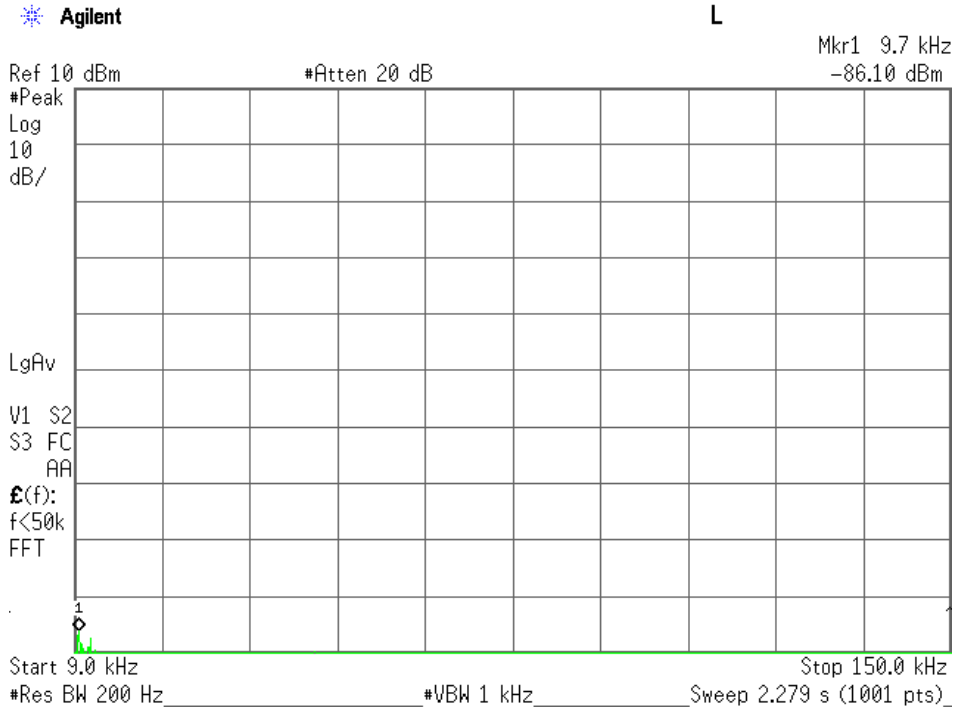

Middle Channel, Out-Of-Band Emissions (150 kHz – 30 MHz)

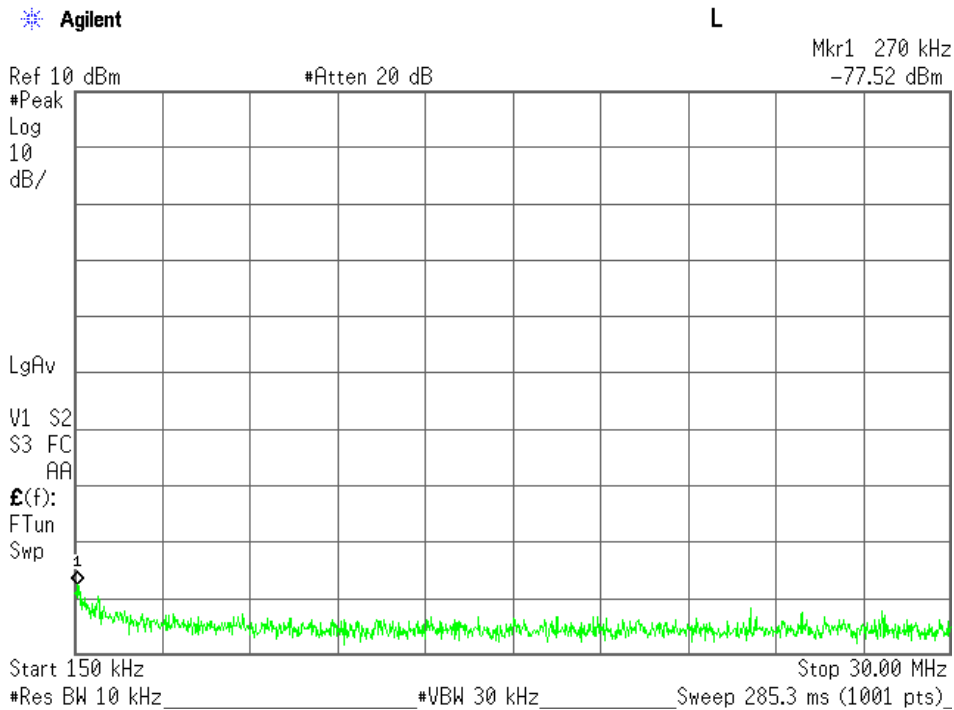

Middle Channel, Out-Of-Band Emissions (30 MHz – 1.2 GHz)

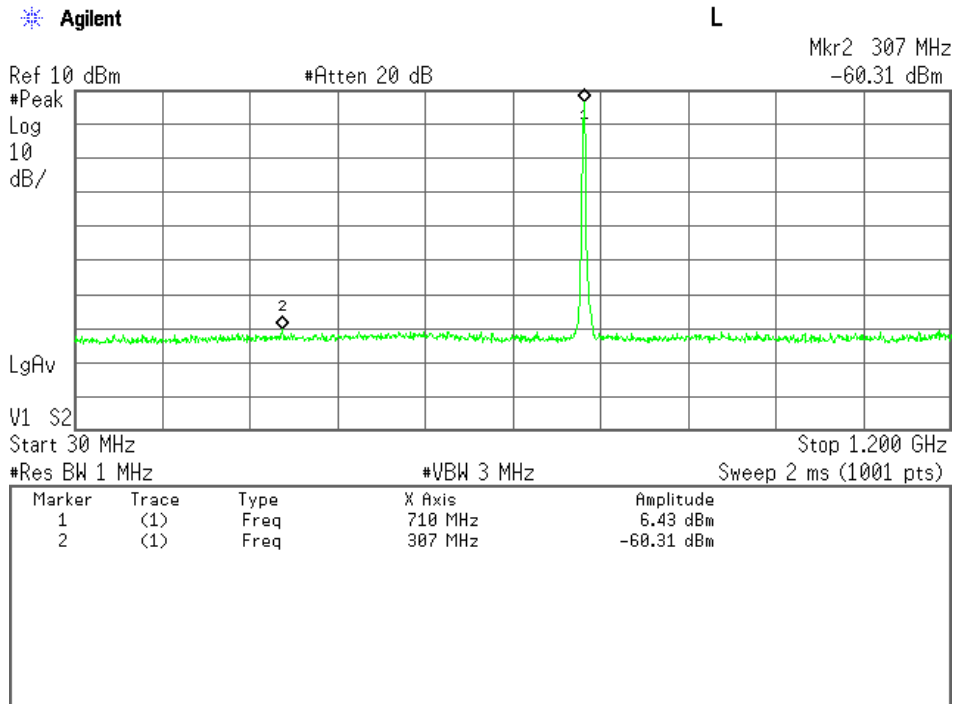

Middle Channel, Out-Of-Band Emissions (1.2 GHz – 10 GHz)

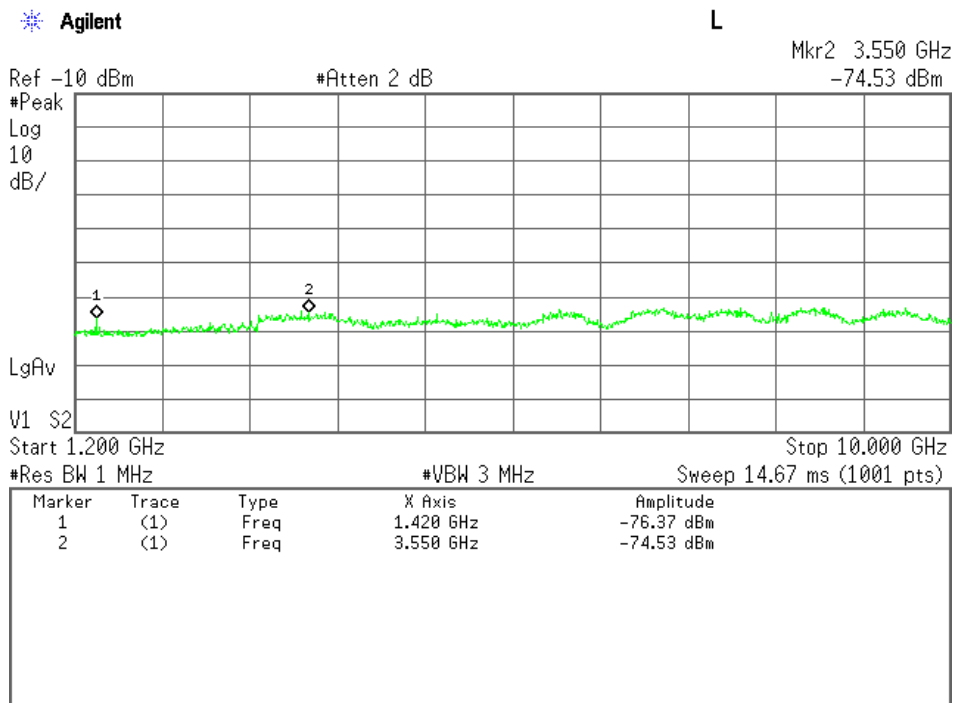

High Channel, Out-Of-Band Emissions (9 kHz – 150 kHz)

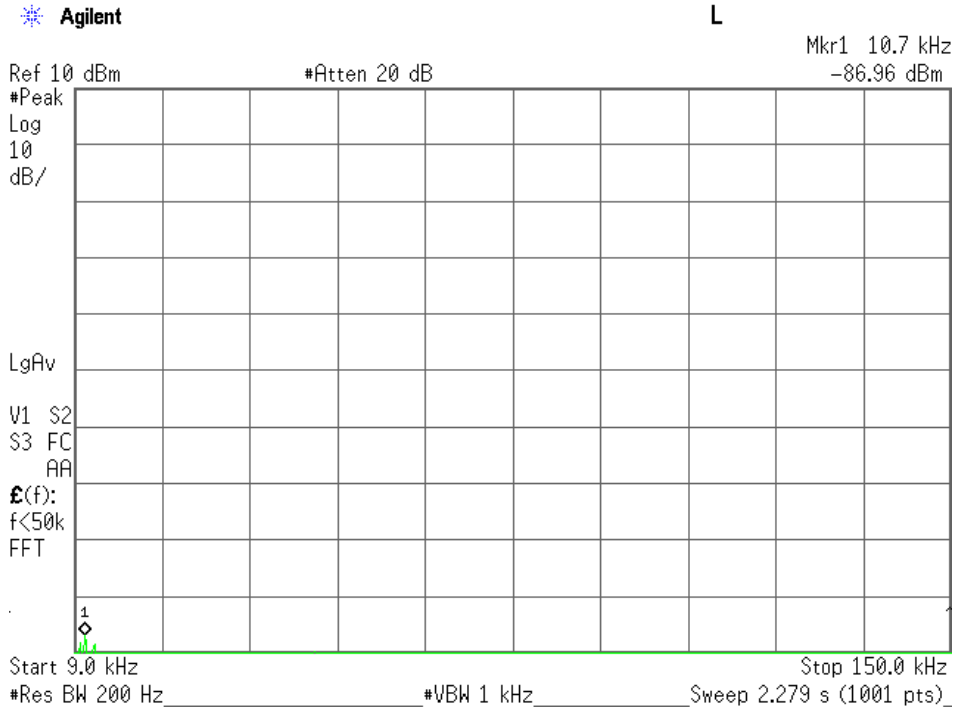

High Channel, Out-Of-Band Emissions (150 kHz – 30 MHz)

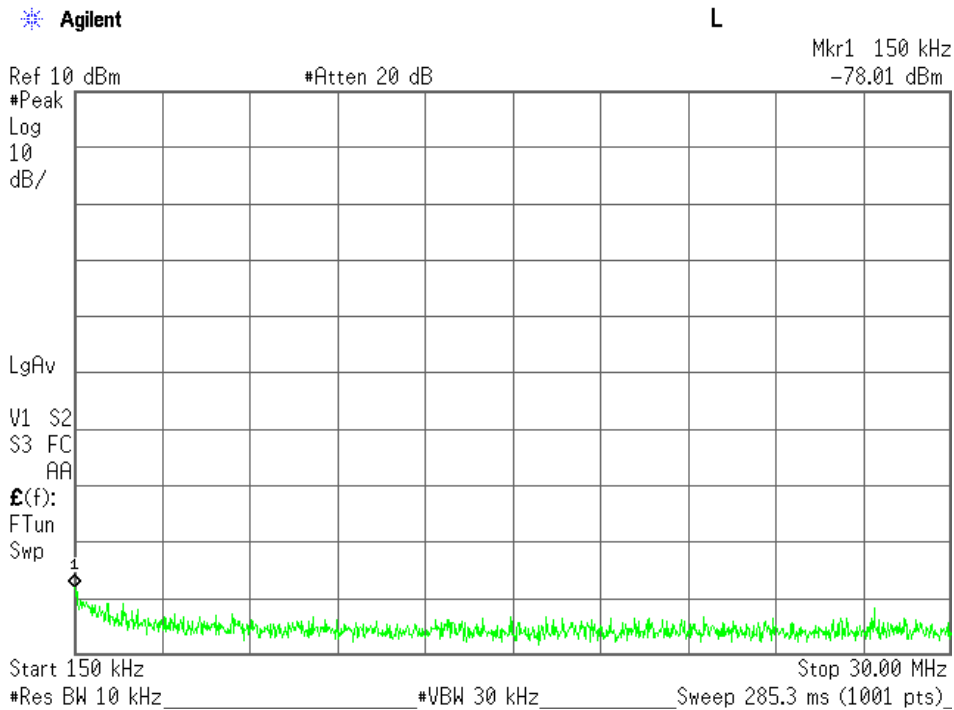

High Channel, Out-Of-Band Emissions (30 MHz – 1.2 GHz)

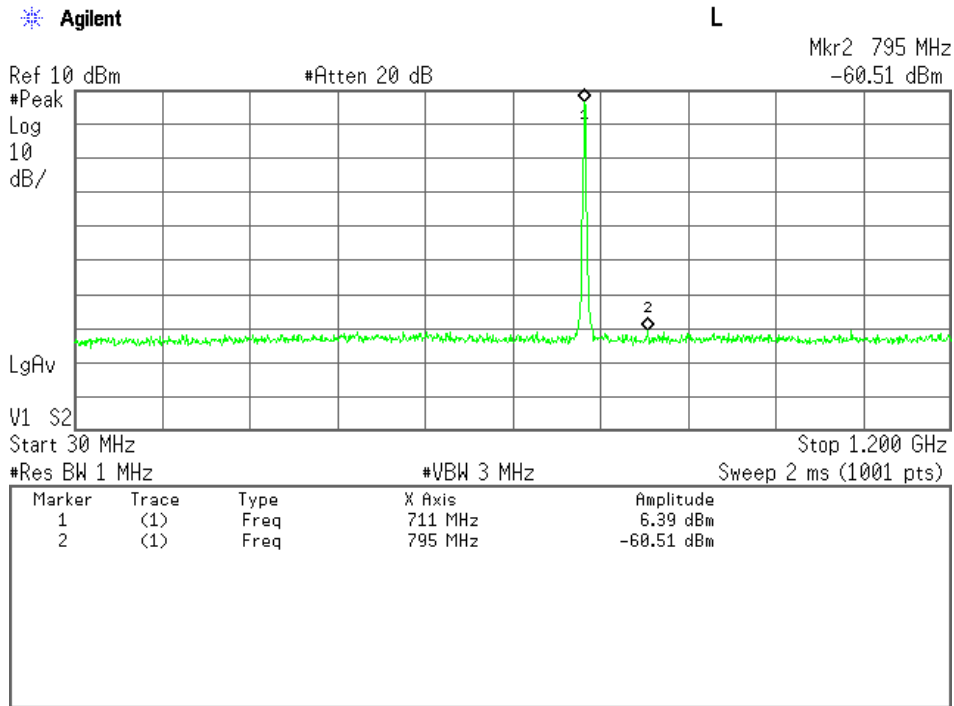

High Channel, Out-Of-Band Emissions (1.2 GHz – 10 GHz)

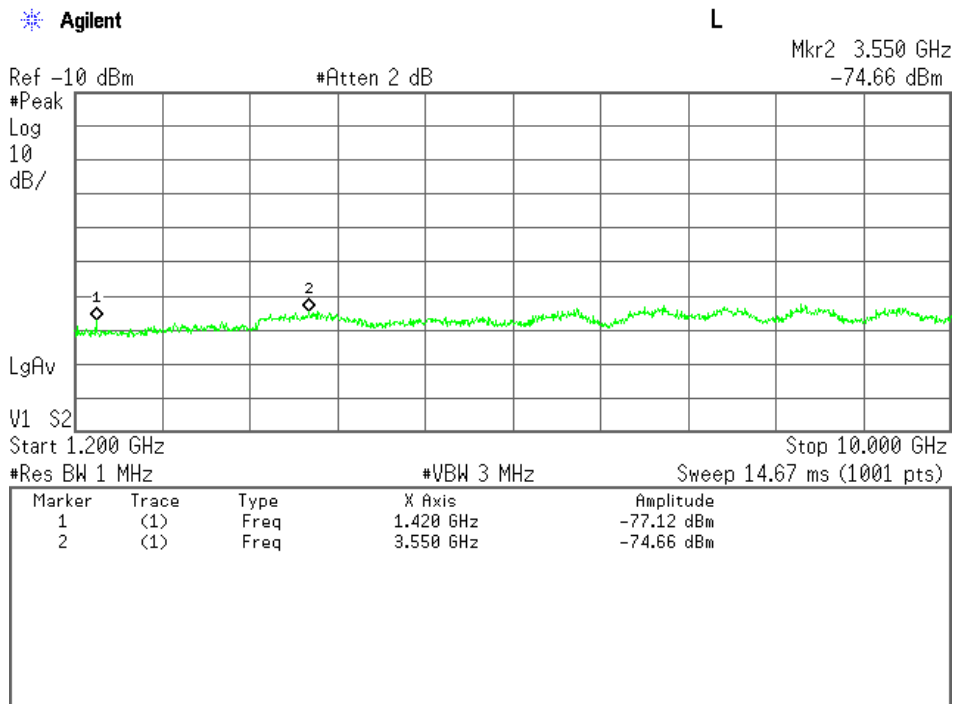

7.6 Band-Edge Emission (§2.1051)

For the requirements, - Applicable - Tested. - Not tested by applicant request.]
 - Not Applicable

For the limits, - Passed - Failed - Not judged

7.6.1 Worst Point and Measurement Uncertainty

Min. Limit Margin 2.2 dB at 704.000 MHz

The Band-Edge level is -15.2 dBm at 704.000 MHz

Uncertainty of Measurement Results +/-1.4 dB(2σ)

Remarks : BW 5 MHz, QPSK (Main Antenna)

7.6.2 Test Site and Instruments

7.6.2.1 Test Site

KITA-KANSAI Testing Center

Test site : SAITO - Anechoic chamber (A1) - Measurement room (M1)
 - Measurement room (M2) - Measurement room (M3)
 - Shielded room (S1) - Shielded room (S2)
 - Shielded room (S3) - Shielded room (S4)

7.6.2.2 Test Instruments

Type	Model	Manufacturer	ID No.	Last Cal.	Interval
Spectrum Analyzer	E4446A	Agilent	A-39	2014/9	1 Year
Attenuator	43KC-20	Anritsu	D-41	2014/7	1 Year
RF Cable	SUCOFLEX102	SUHNER	C-52	2014/8	1 Year

7.6.3 Test Method and Test Setup (Diagrammatic illustration)

The test system is shown as follows:

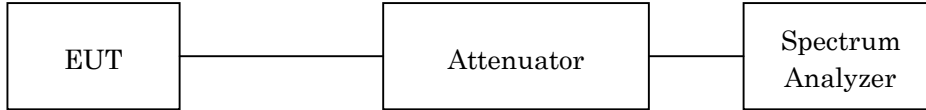

The setting of the spectrum analyzer are shown as follows:

Band-Edge Frequency	704.00 MHz / 716.00 MHz
Res. Bandwidth	100 kHz
Video Bandwidth	300 kHz
Span	20 MHz
Sweep Time	100 ms
Detector	Power Average(RMS)
Trace	Average

7.6.4 Test Data

a) Main Antenna

Test Date : March 16, 2015
Temp.:22°C, Humi:45%

- 1) BW 5MHz
- Mode: QPSK

Channel	Frequency (MHz)	Band-Edge Frequency (MHz)	Level (dBm)	Limits (dBm)	Margin (dB)
23755	706.5	704.0	-15.2 (at 704.0 MHz)	-13.0	+2.2
23825	713.5	716.0	-17.8 (at 716.0 MHz)	-13.0	+4.8

Low Channel(1RB Offset 0), Band-Edge Emission

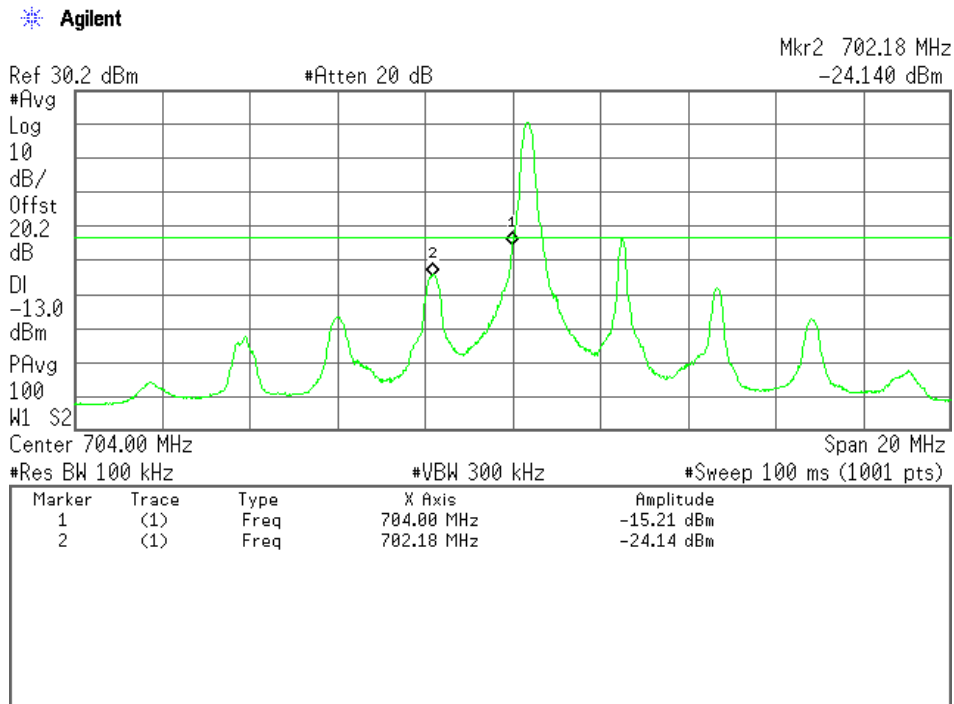

Low Channel(Full RB), Band-Edge Emission

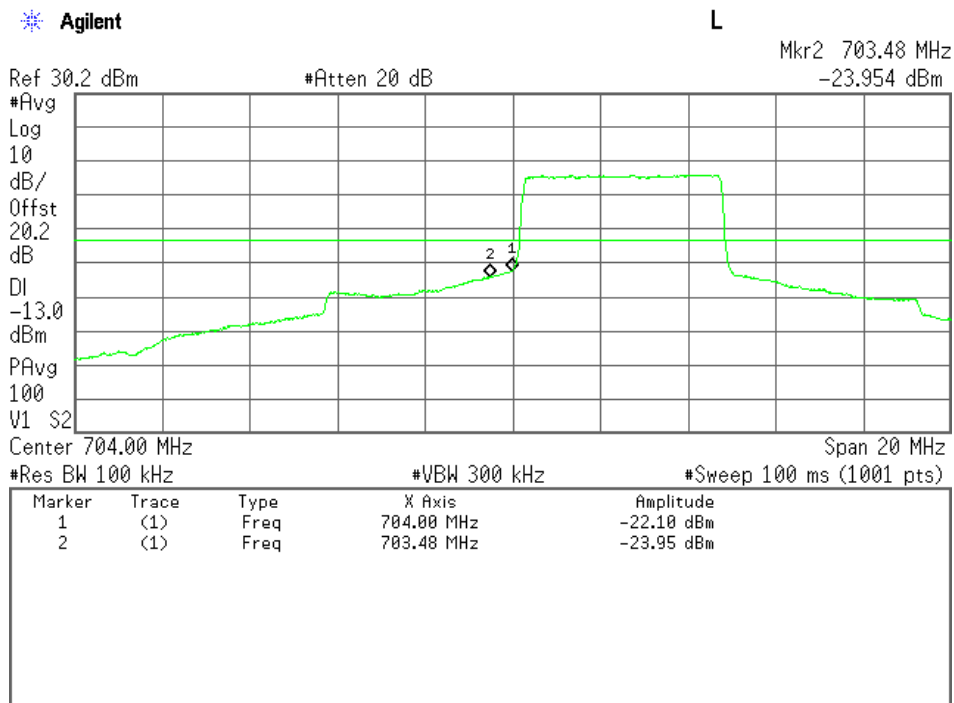

High Channel(1RB Offset 24), Band-Edge Emission

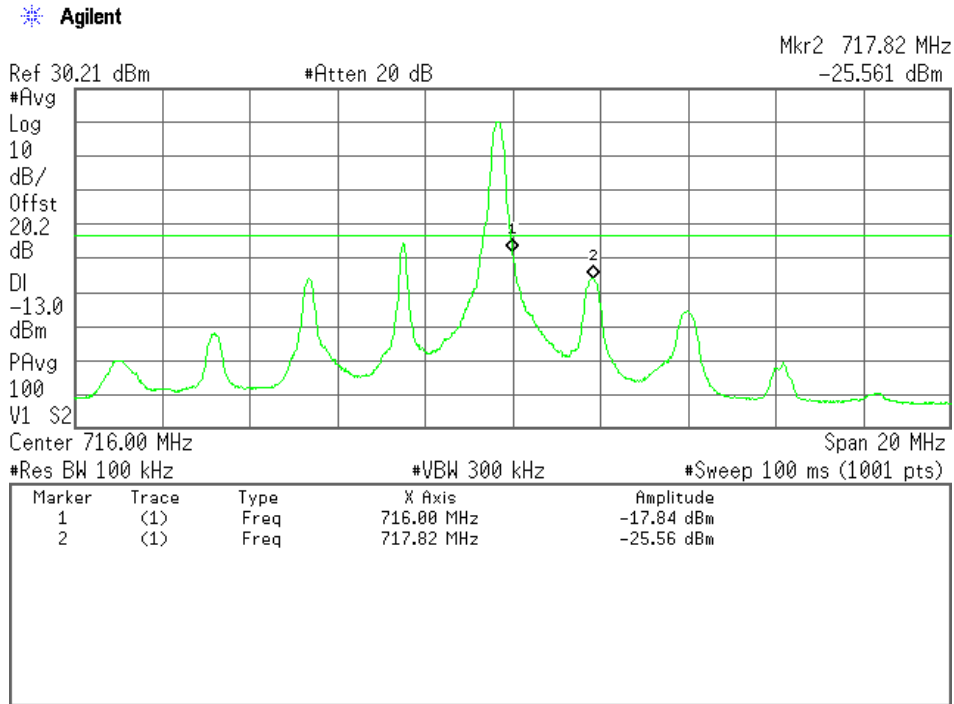

High Channel(Full RB), Band-Edge Emission

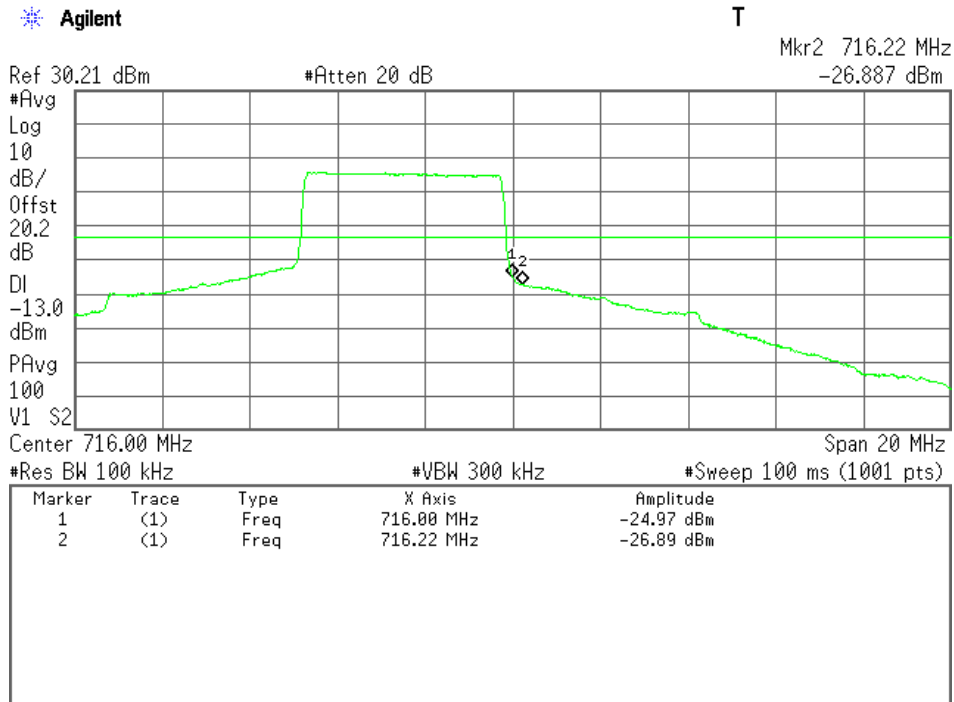

Mode: 16QAM

Channel	Frequency (MHz)	Band-Edge Frequency (MHz)	Level (dBm)	Limits (dBm)	Margin (dB)
23755	706.5	704.0	-16.4 (at 704.0 MHz)	-13.0	+3.4
23825	713.5	716.0	-18.2 (at 716.0 MHz)	-13.0	+5.2

Low Channel(1RB Offset 0), Band-Edge Emission

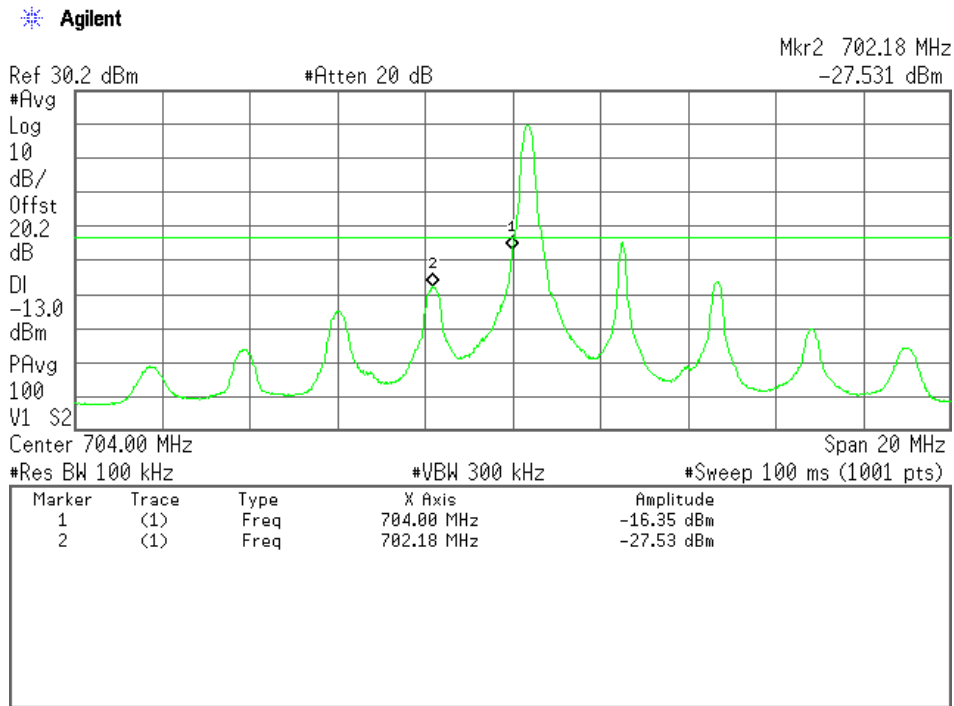

Low Channel(Full RB), Band-Edge Emission

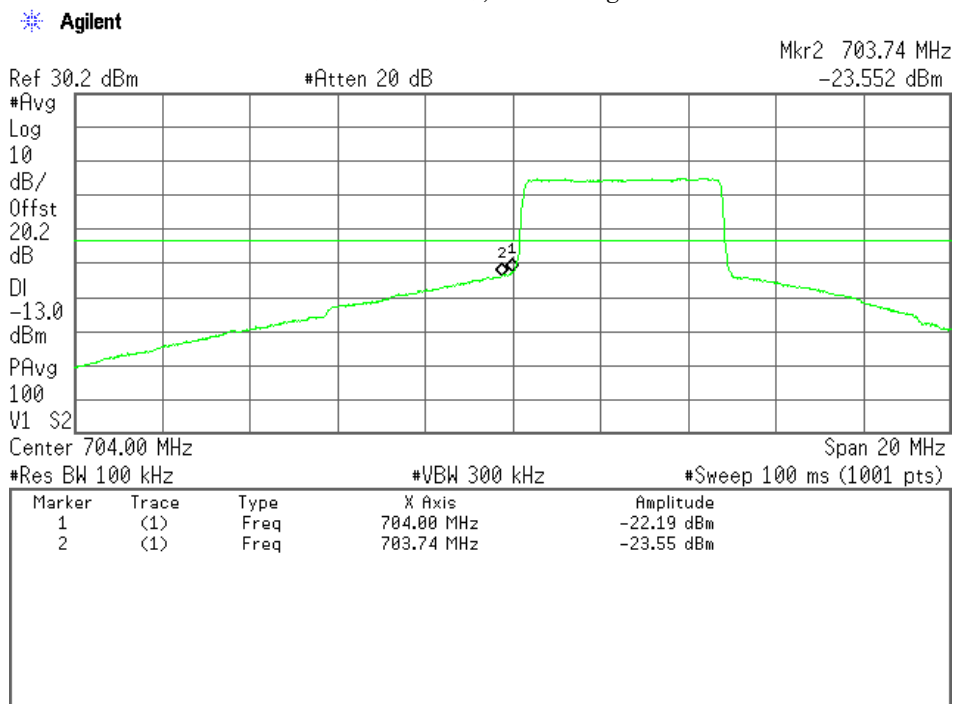

High Channel(1RB Offset 24), Band-Edge Emission

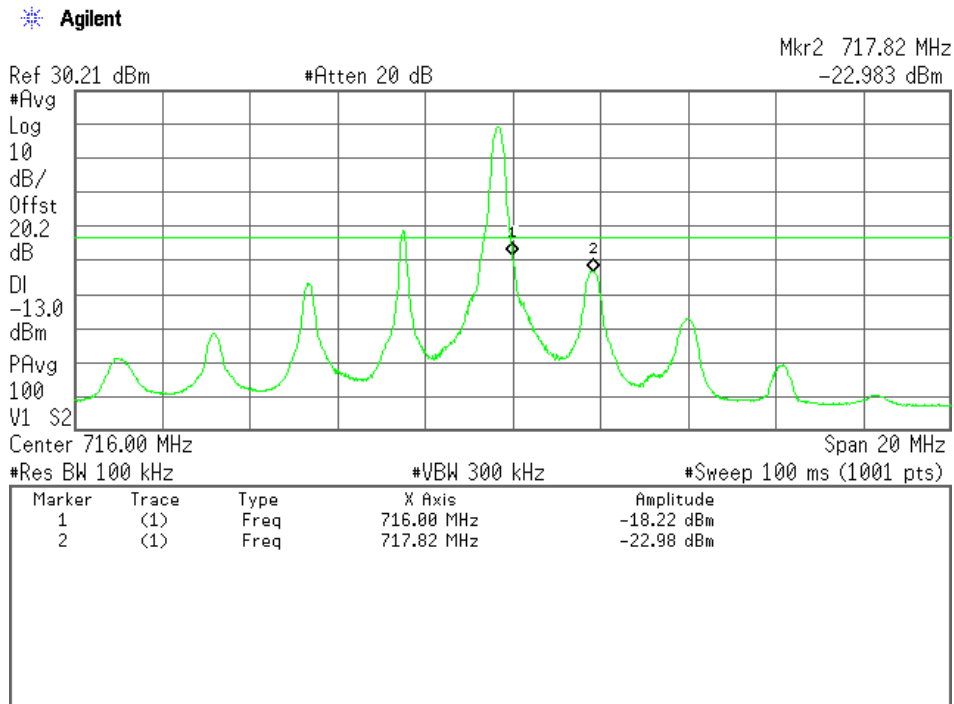

High Channel(Full RB), Band-Edge Emission

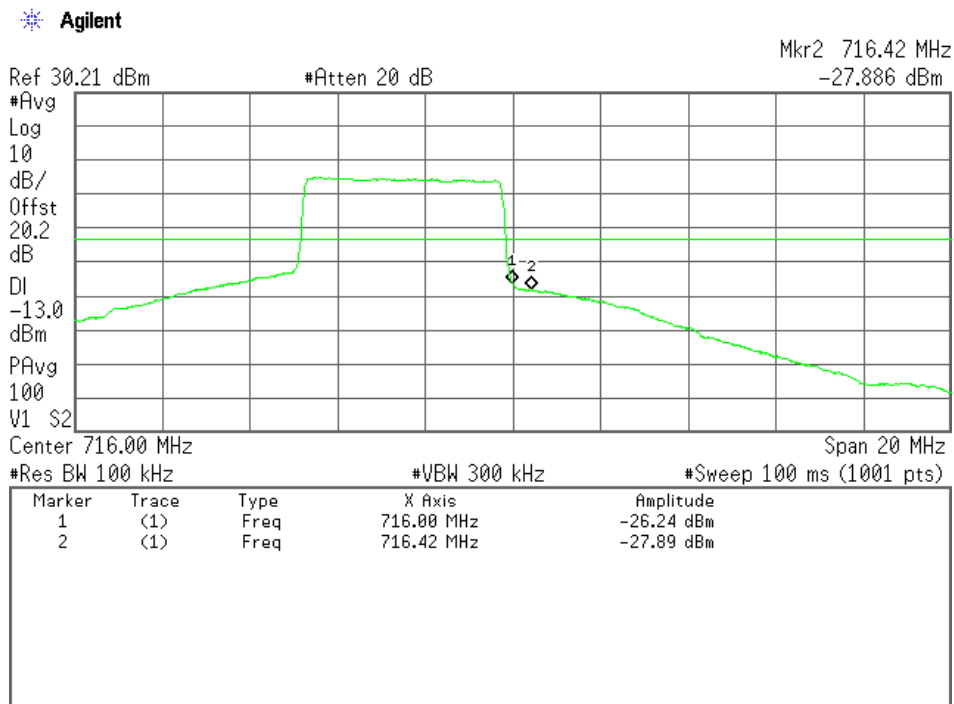

2) BW 10MHz

Mode: QPSK

Channel	Frequency (MHz)	Band-Edge Frequency (MHz)	Level (dBm)	Limits (dBm)	Margin (dB)
23780	709.0	704.0	-27.5 (at 700.2 MHz)	-13.0	+14.5
23800	711.0	716.0	-25.4 (at 719.8 MHz)	-13.0	+12.4

Low Channel(1RB Offset 0), Band-Edge Emission

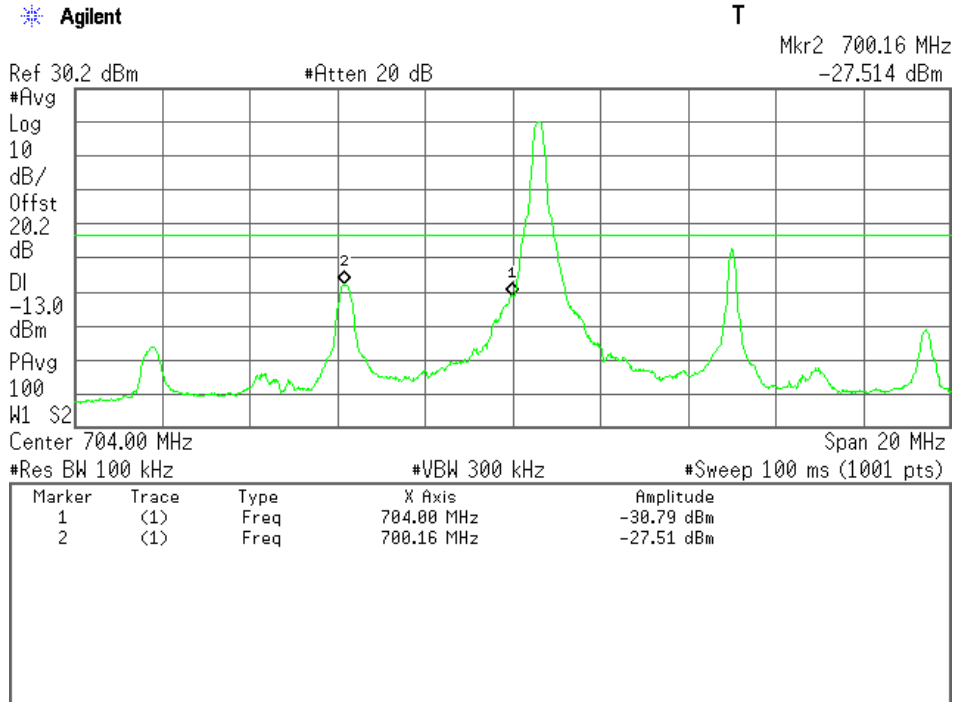

Low Channel(Full RB), Band-Edge Emission

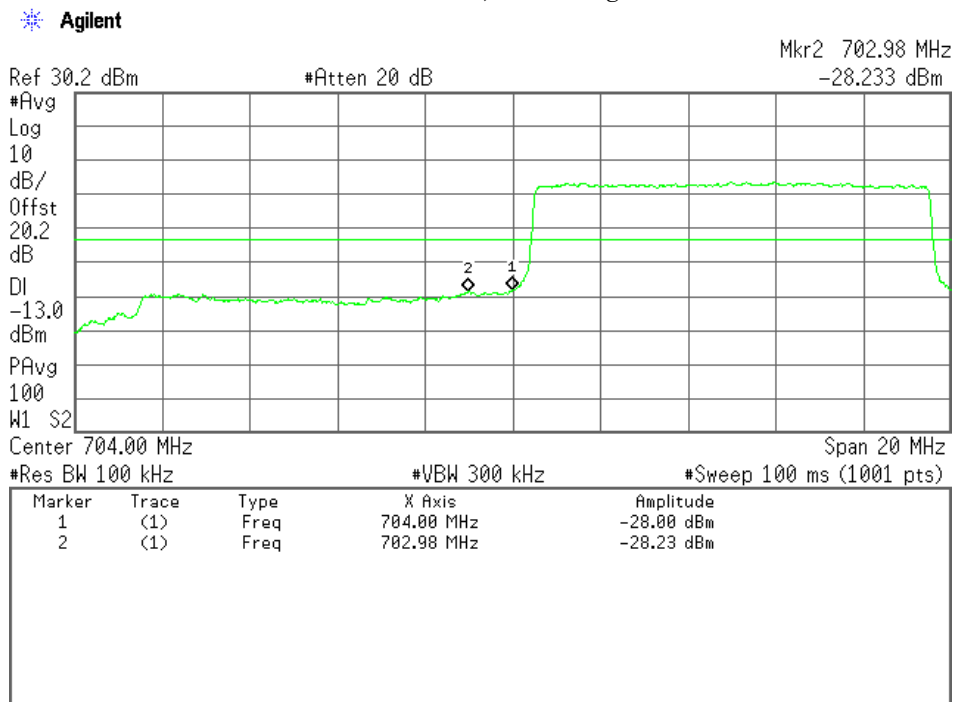

High Channel(1RB Offset 49), Band-Edge Emission

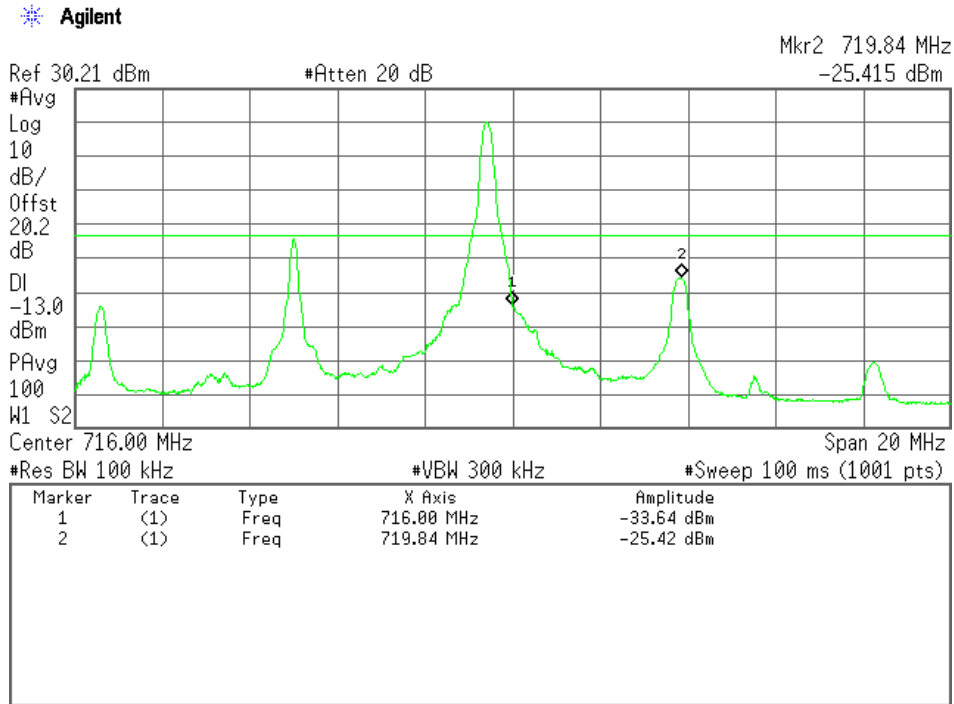

High Channel(Full RB), Band-Edge Emission

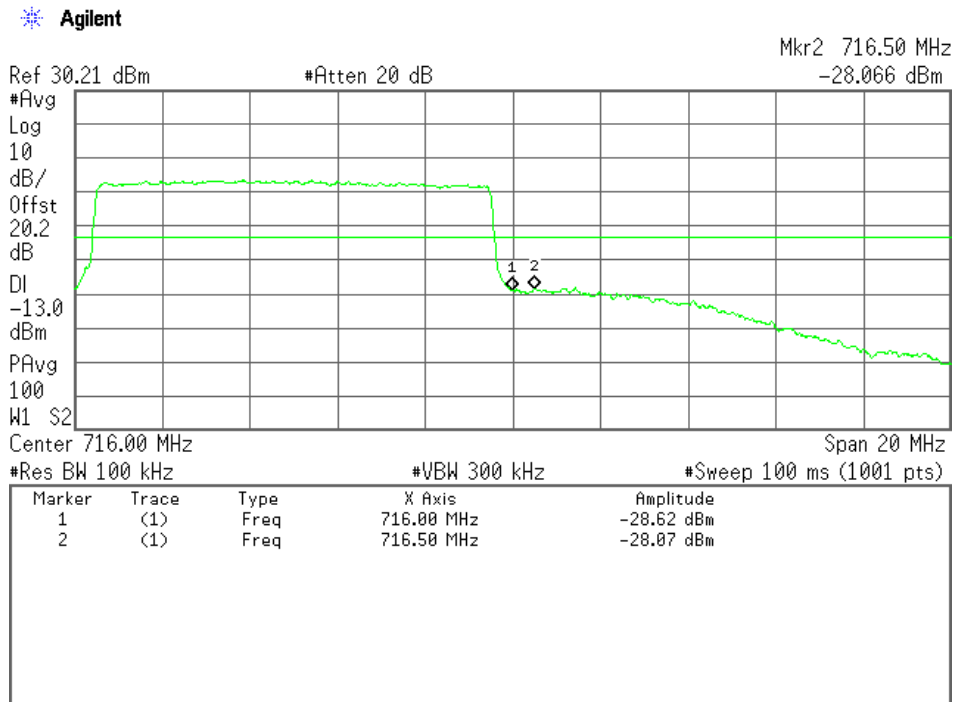

Mode: 16QAM

Channel	Frequency (MHz)	Band-Edge Frequency (MHz)	Level (dBm)	Limits (dBm)	Margin (dB)
23780	709.0	704.0	-26.2 (at 700.2 MHz)	-13.0	+13.2
23800	711.0	716.0	-29.6 (at 719.8 MHz)	-13.0	+16.6

Low Channel(1RB Offset 0), Band-Edge Emission

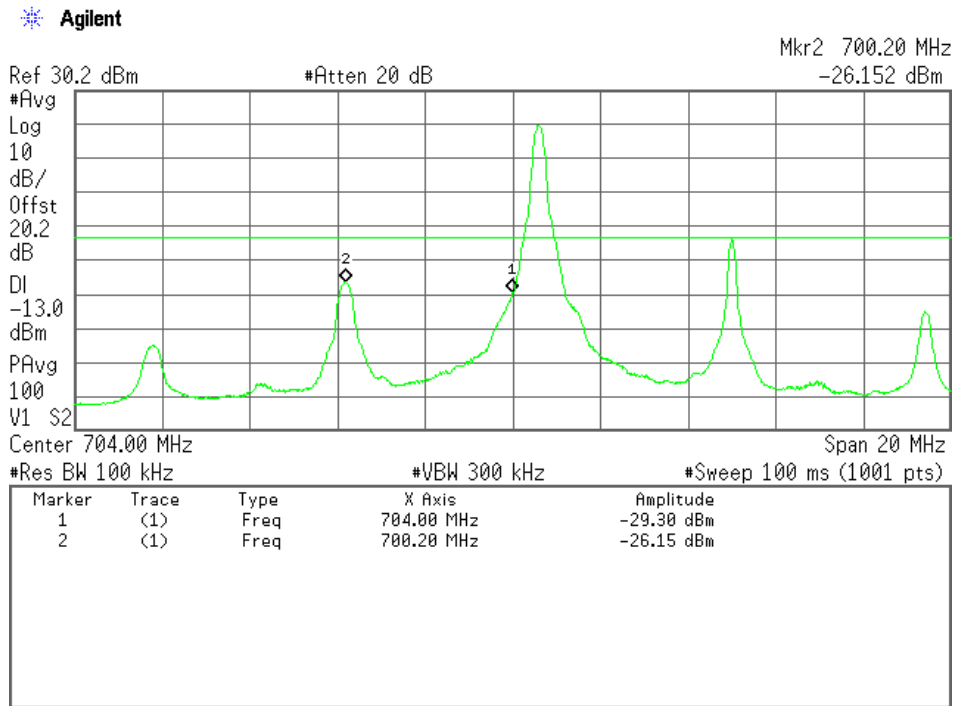

Low Channel(Full RB), Band-Edge Emission

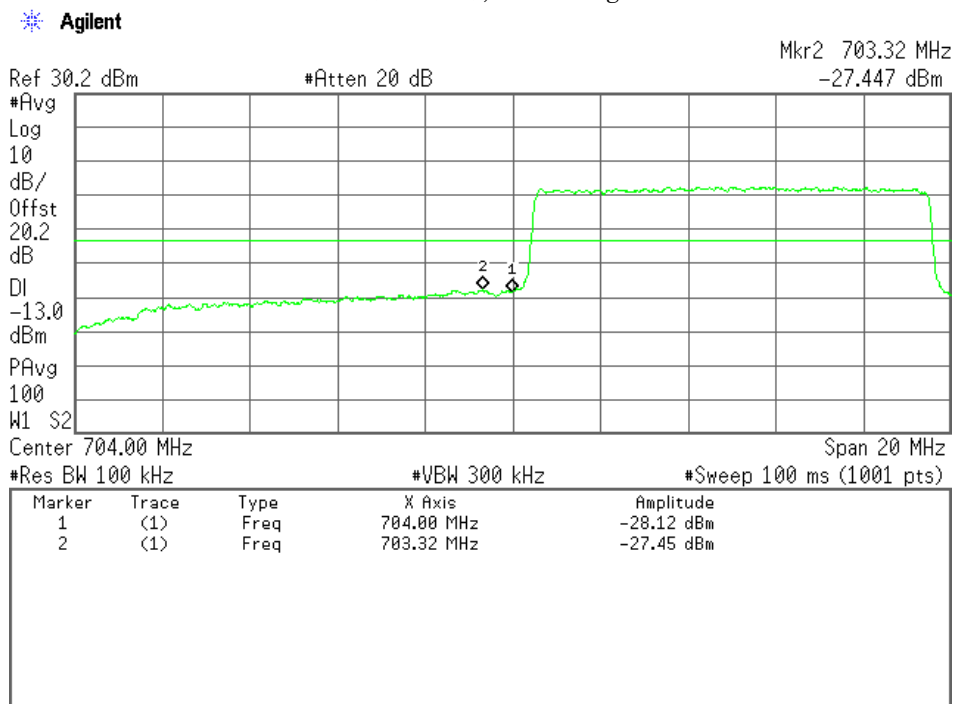

High Channel(1RB Offset 49), Band-Edge Emission

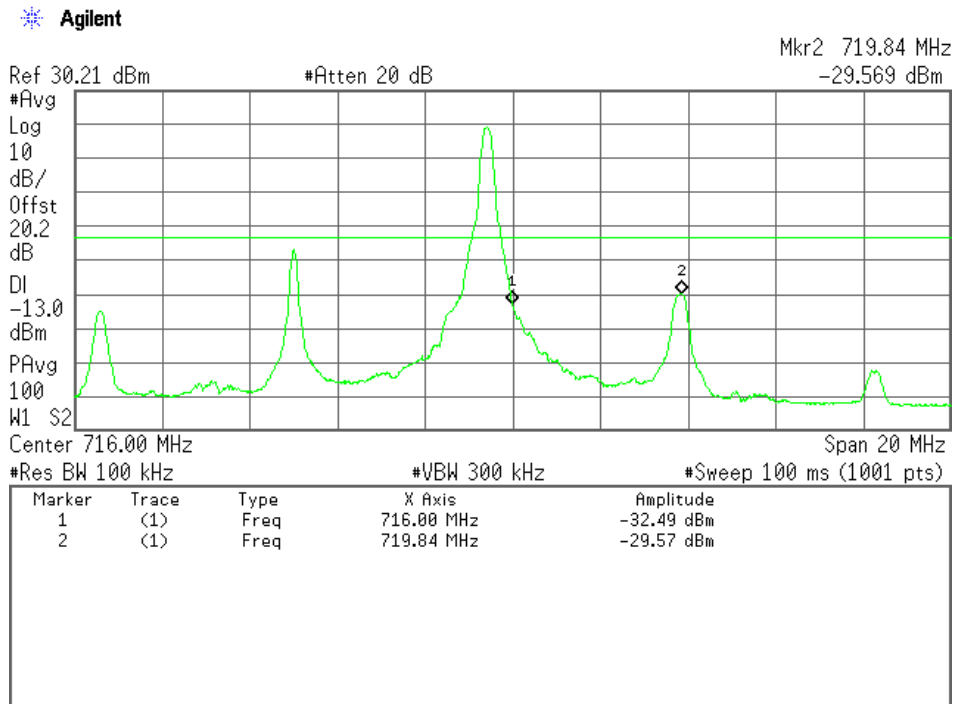

High Channel(Full RB), Band-Edge Emission

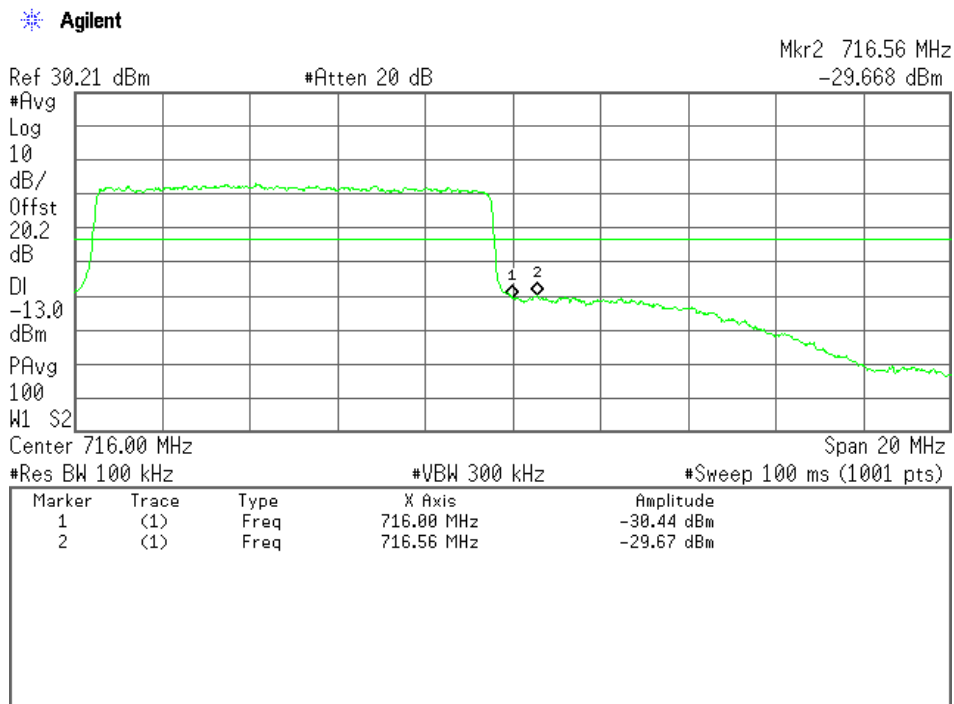

b) Sub AntennaTest Date : March 24, 2015Temp.:22°C, Humi:30%

1) BW 5MHz

Mode: QPSK

Channel	Frequency (MHz)	Band-Edge Frequency (MHz)	Level (dBm)	Limits (dBm)	Margin (dB)
23755	706.5	704.0	-15.4 (at 704.0 MHz)	-13.0	+2.4
23825	713.5	716.0	-17.5 (at 716.0 MHz)	-13.0	+4.5

Low Channel(1RB Offset 0), Band-Edge Emission

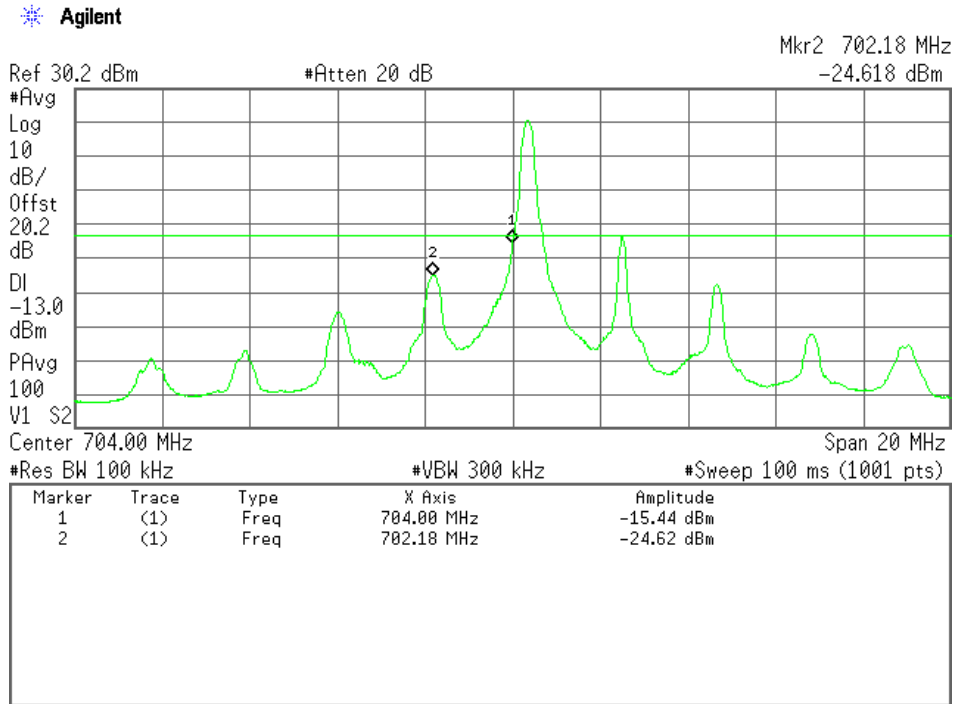

Low Channel(Full RB), Band-Edge Emission

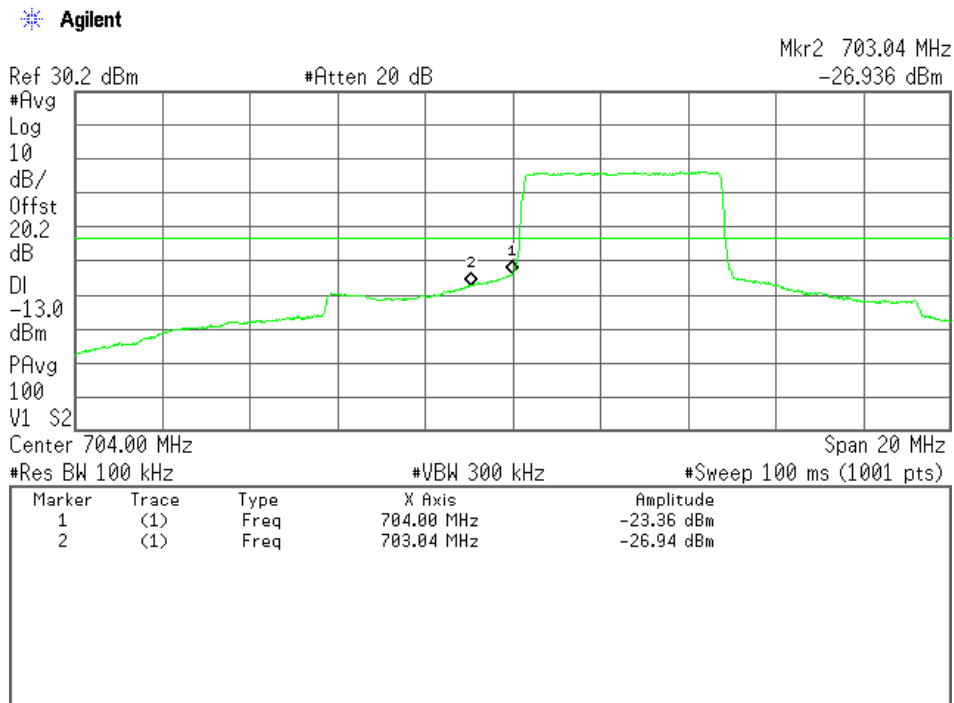

High Channel(1RB Offset 24), Band-Edge Emission

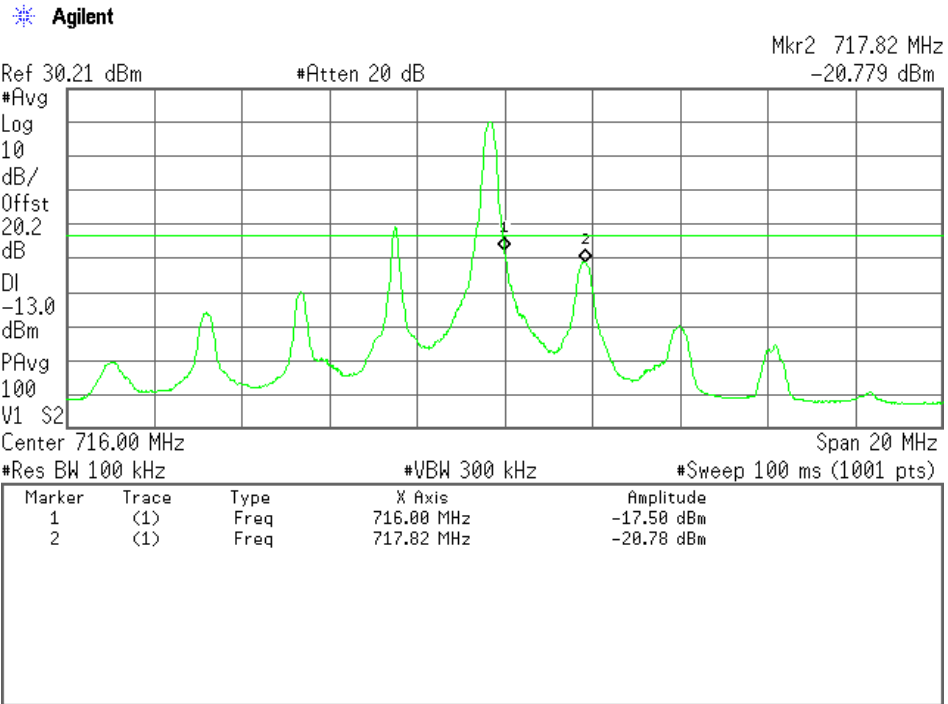

High Channel(Full RB), Band-Edge Emission

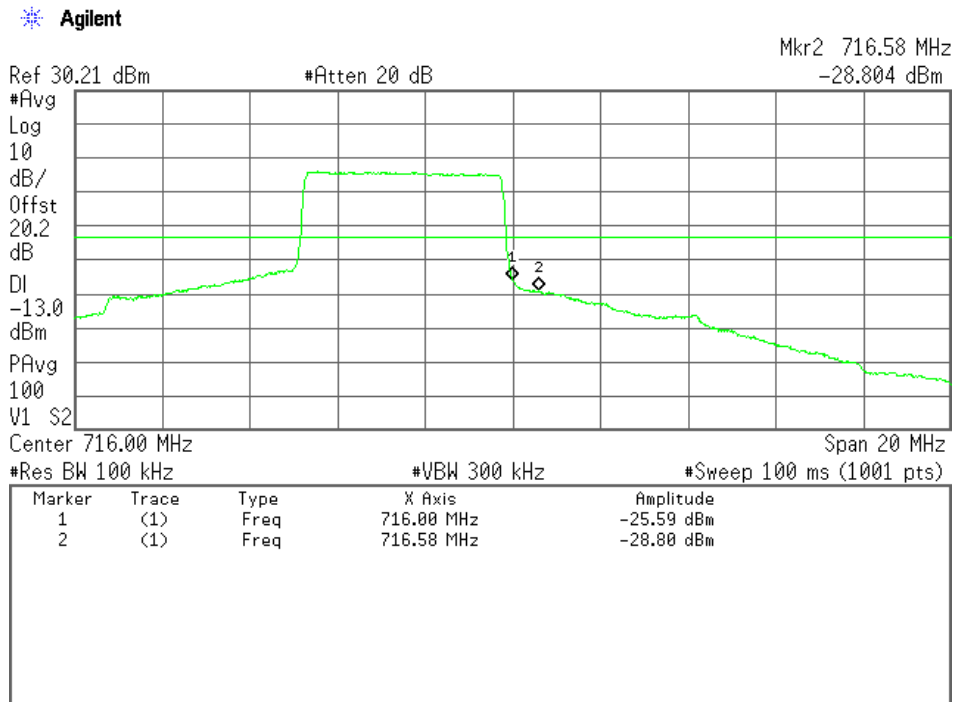

Mode: 16QAM

Channel	Frequency (MHz)	Band-Edge Frequency (MHz)	Level (dBm)	Limits (dBm)	Margin (dB)
23755	706.5	704.0	-16.6 (at 704.0 MHz)	-13.0	+3.6
23825	713.5	716.0	-18.5 (at 716.0 MHz)	-13.0	+5.5

Low Channel(1RB Offset 0), Band-Edge Emission

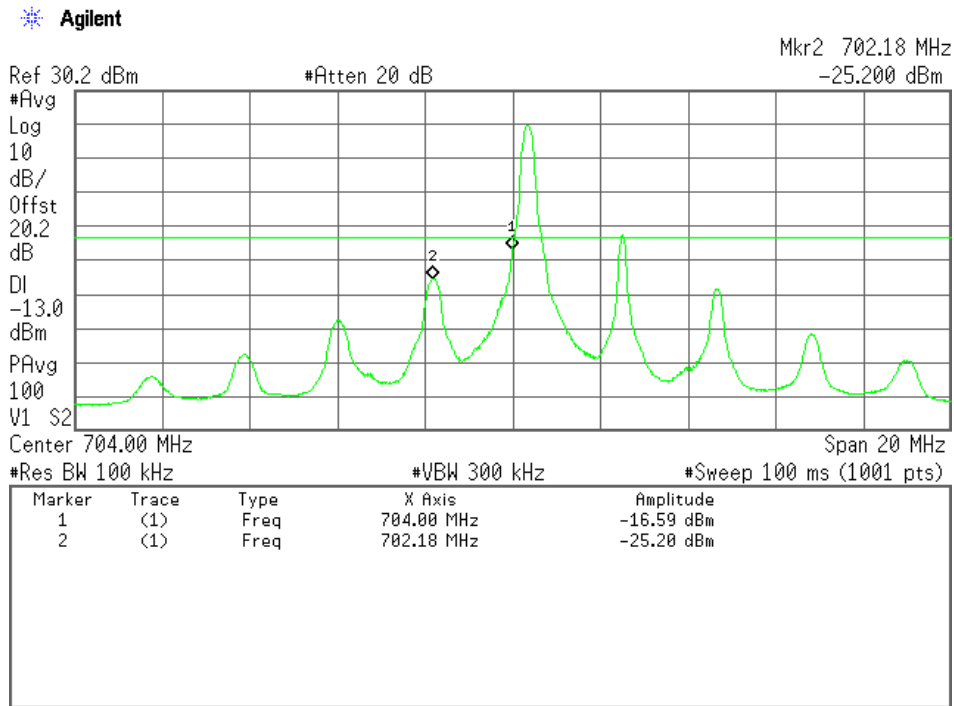

Low Channel(Full RB), Band-Edge Emission

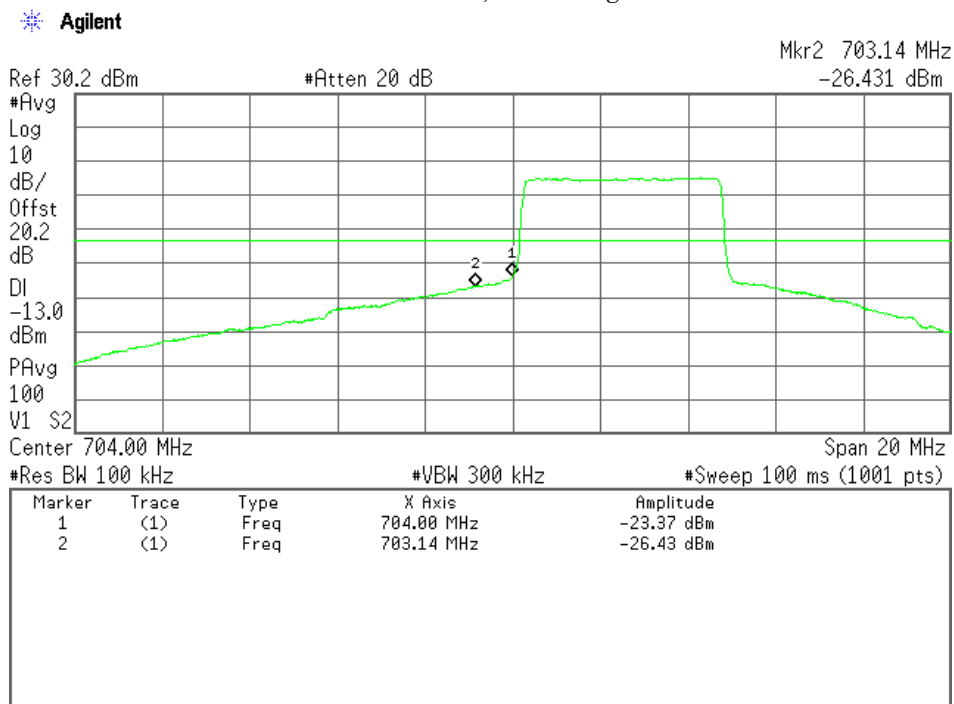

High Channel(1RB Offset 24), Band-Edge Emission

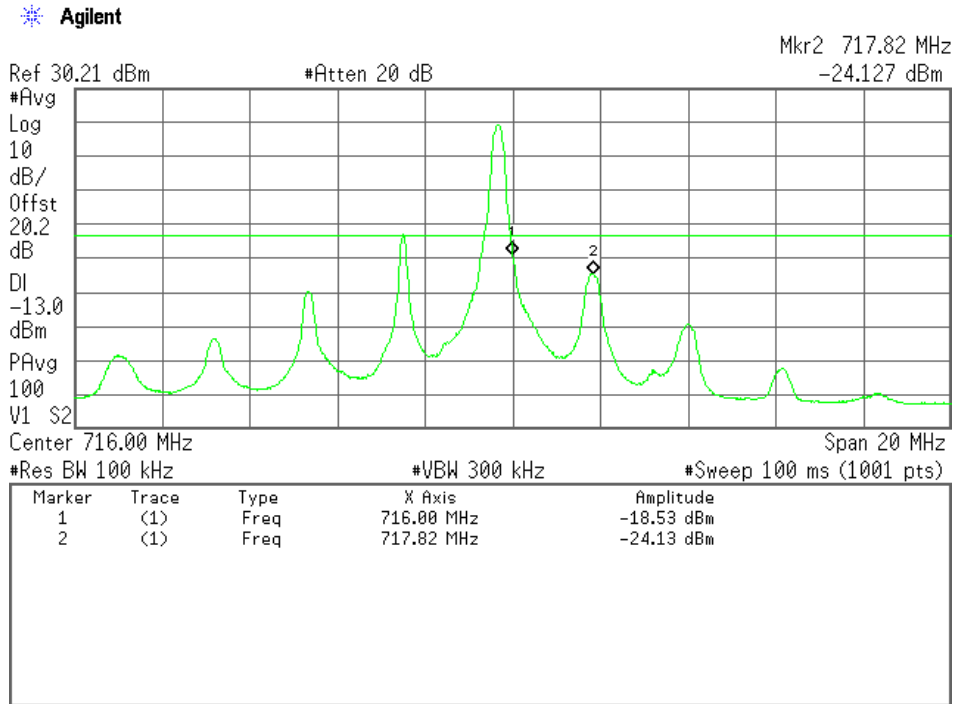

High Channel(Full RB), Band-Edge Emission

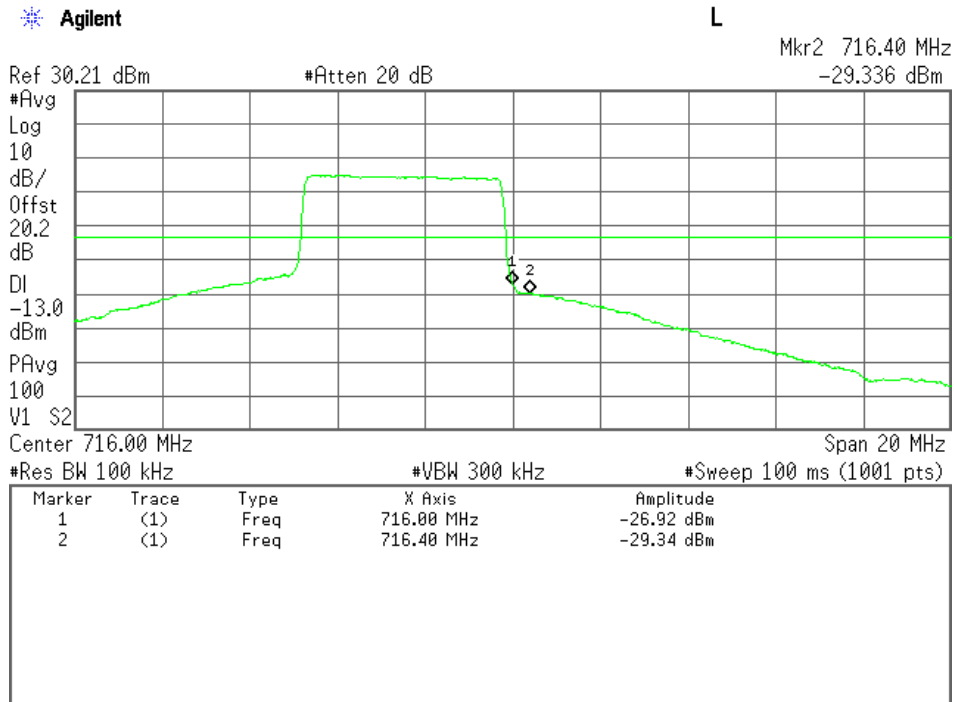

2) BW 10MHz

Mode: QPSK

Channel	Frequency (MHz)	Band-Edge Frequency (MHz)	Level (dBm)	Limits (dBm)	Margin (dB)
23780	709.0	704.0	-23.2 (at 700.2 MHz)	-13.0	+10.2
23800	711.0	716.0	-27.9 (at 719.8 MHz)	-13.0	+14.9

Low Channel(1RB Offset 0), Band-Edge Emission

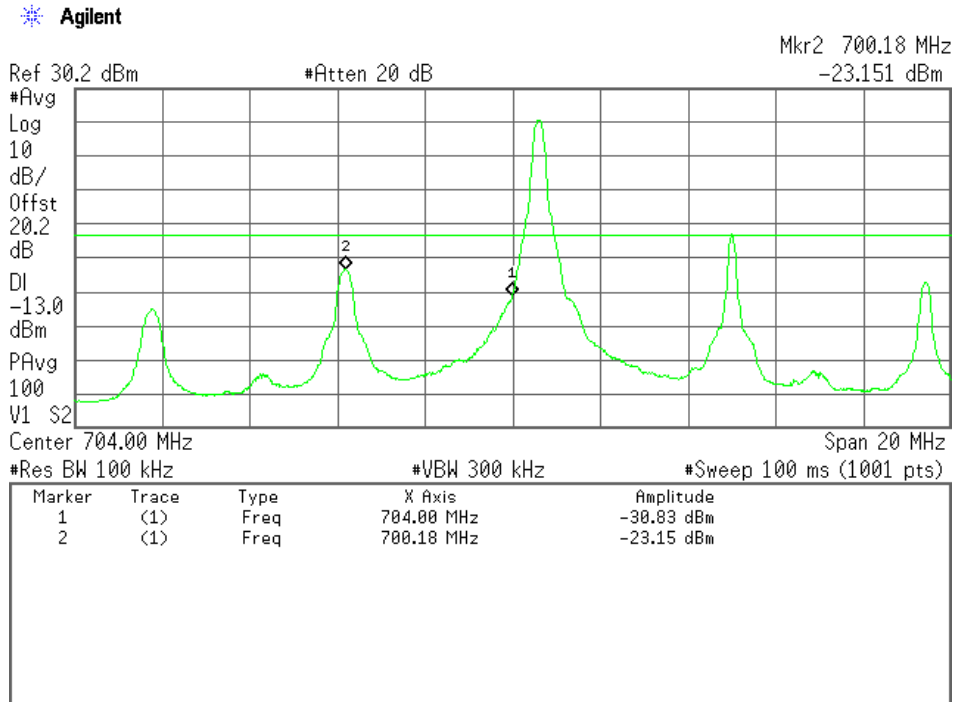

Low Channel(Full RB), Band-Edge Emission

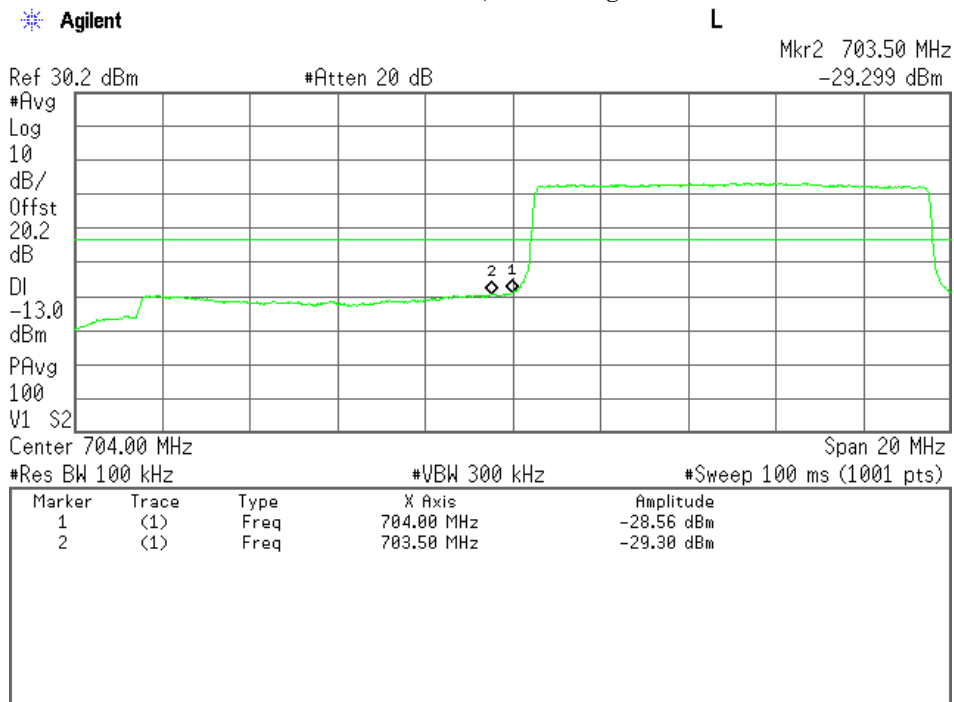

High Channel(1RB Offset 49), Band-Edge Emission

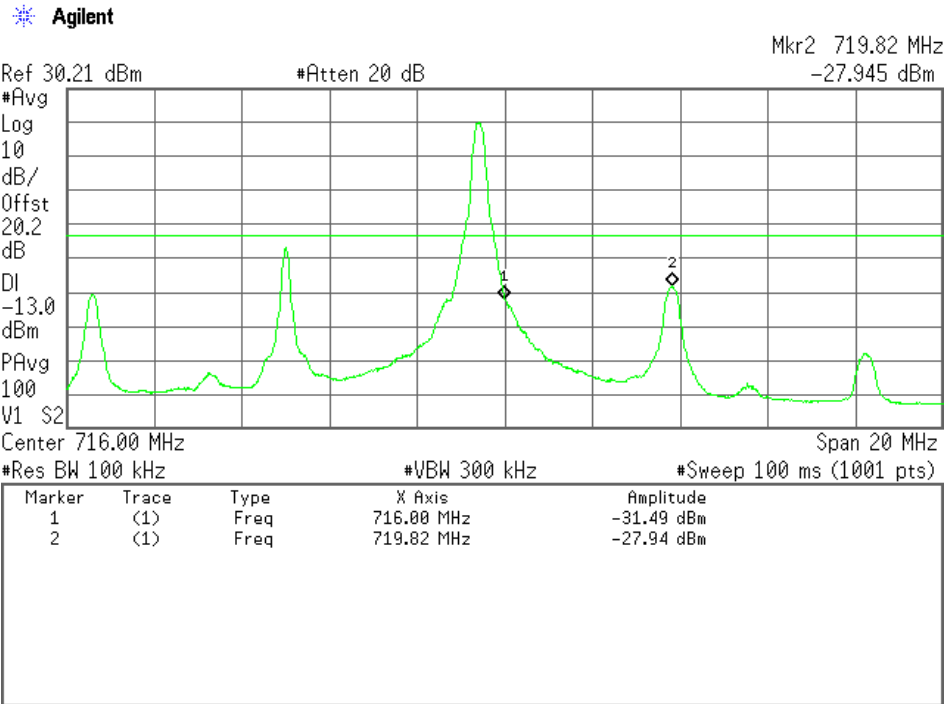

High Channel(Full RB), Band-Edge Emission

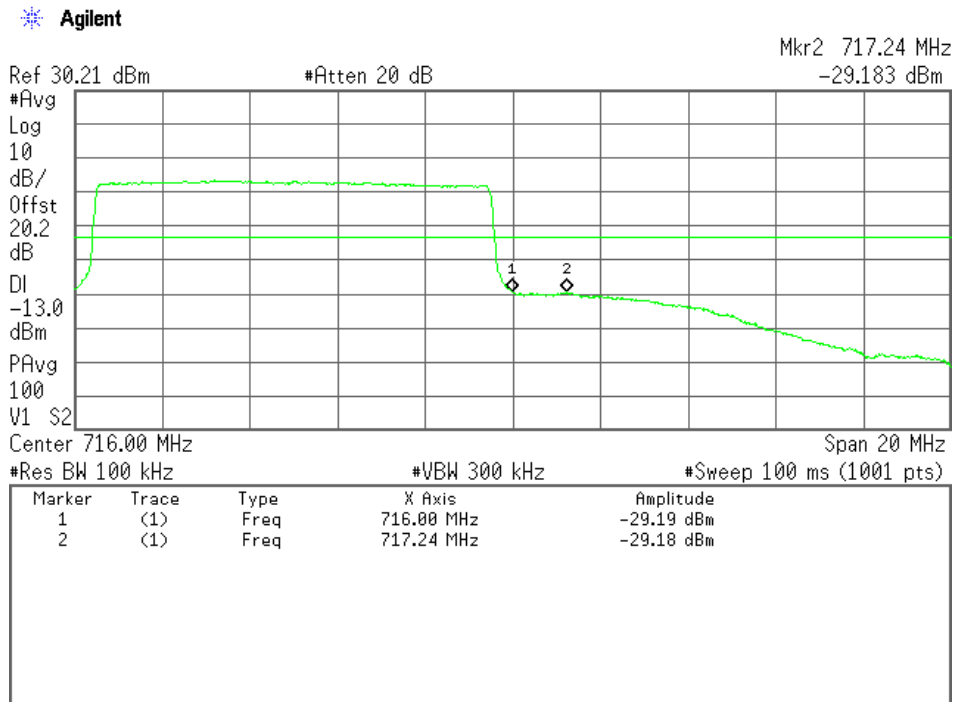

Mode: 16QAM

Channel	Frequency (MHz)	Band-Edge Frequency (MHz)	Level (dBm)	Limits (dBm)	Margin (dB)
23780	709.0	704.0	-24.1 (at 700.2 MHz)	-13.0	+11.1
23800	711.0	716.0	-28.7 (at 719.8 MHz)	-13.0	+15.7

Low Channel(1RB Offset 0), Band-Edge Emission

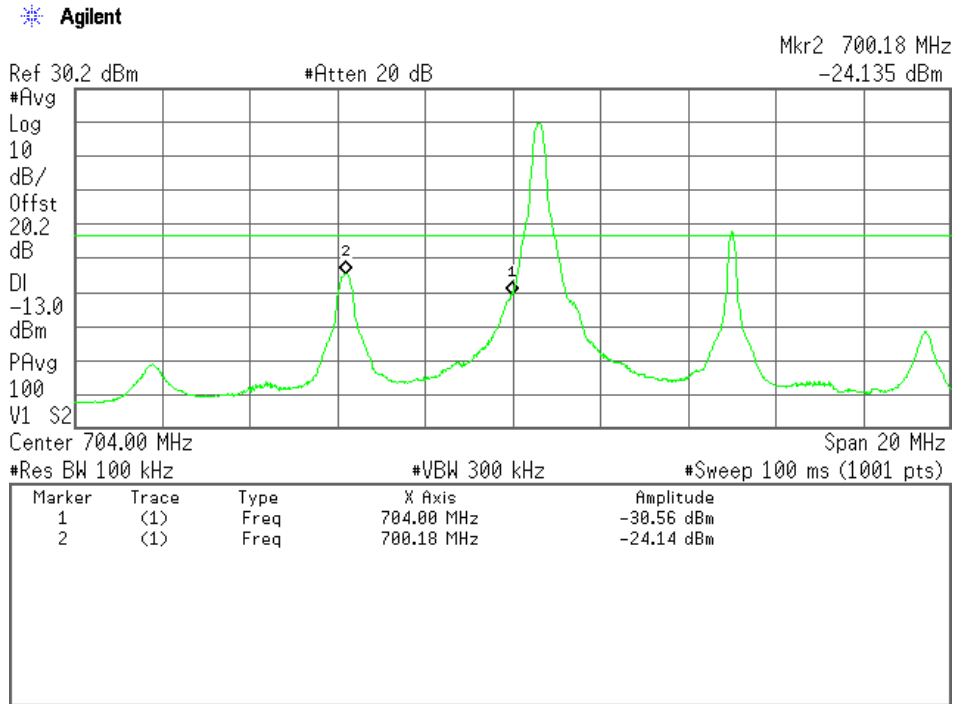

Low Channel(Full RB), Band-Edge Emission

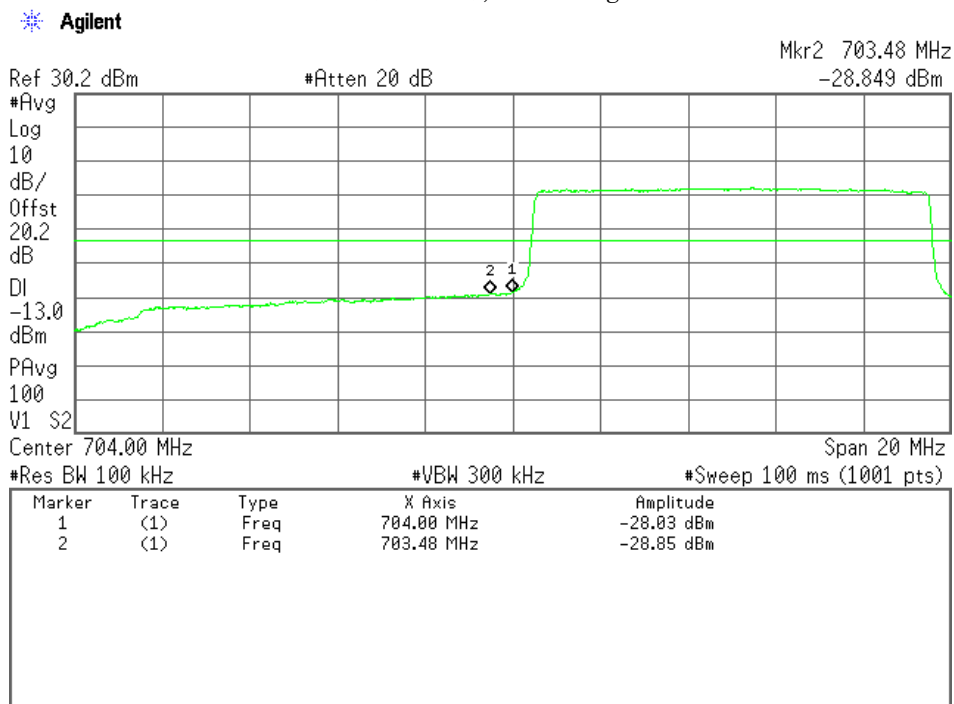

High Channel(1RB Offset 49), Band-Edge Emission

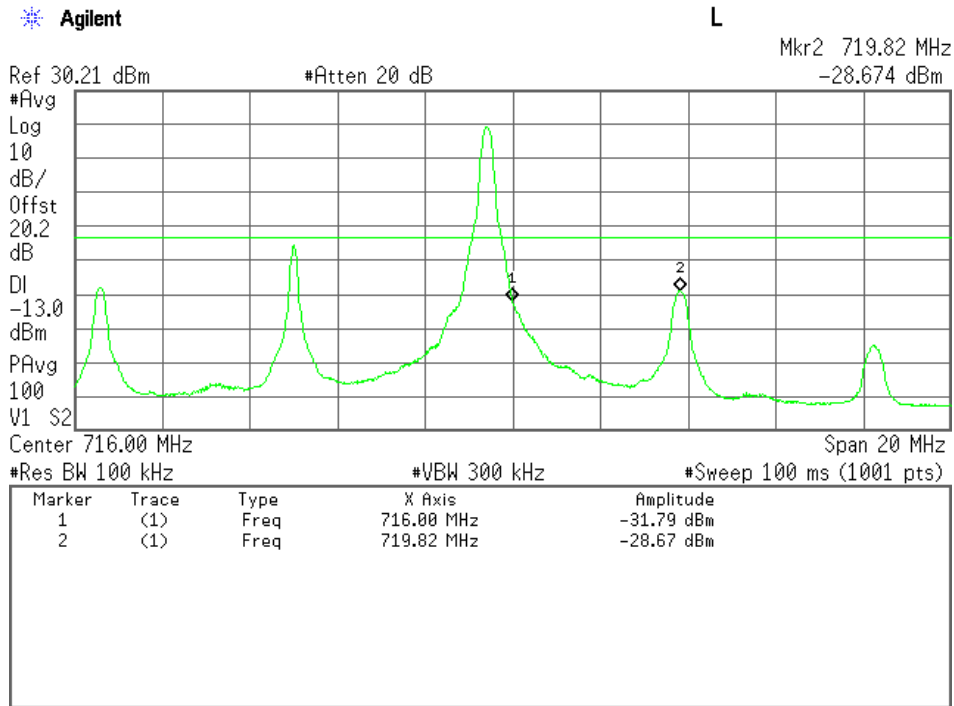

High Channel(Full RB), Band-Edge Emission

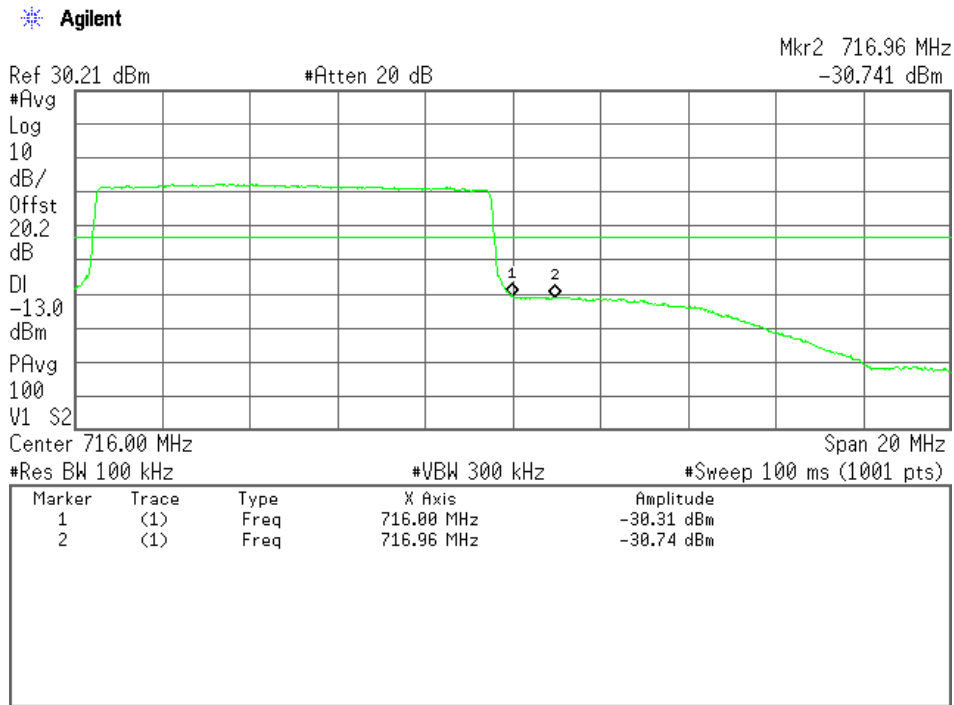

7.7 Field Strength of Spurious Radiation (§2.1053)

For the requirements, - Applicable - Tested. - Not tested by applicant request.]
 - Not Applicable

For the limits, - Passed - Failed - Not judged

7.7.1 Worst Point and Measurement Uncertainty

Min. Limit Margin >32.5 dB at 6358.5/6381/6390/
6399/6421.5 MHz

Uncertainty of Measurement Results 30 MHz – 1000 MHz +/-1.6 dB(2σ)
 above 1 GHz +/-1.8 dB(2σ)

Remarks : _____

7.7.2 Test Site and Instruments

7.7.2.1 Test Site

KITA-KANSAI Testing Center SAITO EMC Branch

- Anechoic chamber A1 - Anechoic chamber A2

7.7.2.2 Test Instruments

Type	Model	Manufacturer	ID No.	Last Cal.	Interval
Test Receiver	ESU26	Rohde & Schwarz	A-6	2014/5	1 Year
Signal Generator	E8257A	Agilent	B-39	2014/8	1 Year
Power Meter	N1911A	Agilent	B-63	2014/7	1 Year
Power Sensor	N1921A	Agilent	B-64	2014/7	1 Year
Horn Antenna	91888-2	EATON	C-41-1	2014/7	1 Year
Horn Antenna	91889-2	EATON	C-41-2	2014/7	1 Year
Horn Antenna	3160-05	EATON	C-56	2014/6	1 Year
Horn Antenna	3160-06	EATON	C-57	2014/6	1 Year
Horn Antenna	3160-07	EATON	C-58	2014/6	1 Year
RF Cable	SUCOFLEX104	SUHNER	C-66	2015/1	1 Year
RF Cable	SUCOFLEX104	SUHNER	C-67	2015/1	1 Year
Attenuator	2-10	Weinschel	D-79	2014/11	1 Year
Attenuator	54-10	Weinschel	D-29	2014/9	1 Year
Pre-Amplifier	TPA0118-36	TOYO	A-37	2014/5	1 Year
HPF	HPM5010S	MICRO-TRONICS	D-94	2015/2	1 Year

7.7.3 Test Method and Test Setup (Diagrammatic illustration)

Step 1) The spurious radiation for transmitter were measured at the distance 3 m away from the EUT which was placed on a non-conducted support 0.8 m in height and was varying at three orthogonal axes. The receiving antenna was oriented for vertical polarization and varied from 1 m to 4 m until the maximum emission level was detected on the measuring instrument. The EUT was rotated 360 degrees until the maximum emission was received. The measurement was also repeated with the receiving antenna in the horizontal polarization.

This test was carried out using the half-wave dipole antenna for up to 1GHz and using the horn antenna for above 1 GHz.

Step 2)

A) Up to 1 GHz

The ERP measurement was carried out with according to Step 2 in Clause 7.2.4. Then the RF power in the substitution antenna half-wave dipole antenna for up to 1 GHz and the substitution horn antenna for above 1 GHz.

The ERP is calculated in the following equation.

$$ERP(dBm) = P (dBm) - (Balun Loss of the half-wave dipole Ant. (dB)) + Cable Loss (dB)$$

B) Above 1 GHz

The ERP is calculated from the maximum emission level by the following formula.

$$\frac{e^2}{120\pi} = \frac{eirp}{4\pi d^2} \quad \text{---(Eq.1)}$$

$$erp = eirp - Gd \quad \text{---(Eq.2)}$$

Where, $e[V / m]$: Field Strength at measuring distance(d=3m)

$eirp[W]$: Equivalent Isotropic Radiated Power

$erp[W]$: Effective Radiated Power

$Gd(dBi)$: Gain of the substitution half-wave dipole antenna(2.15dBi)

$$eirp = \frac{(de)^2}{30} = \frac{3}{10} e^2$$

$$\therefore 10\log(eirp) = 20\log(e) + 10\log(3/10) = 20\log(e) - 5.23$$

$$10\log(eirp) = EIRP[dBm] - 30$$

$$20\log(e) = E[dB(\mu V / m)] - 120$$

$$\therefore EIRP = E - 120 + 30 - 5.23 = E - 95.23$$

$$\therefore ERP[dBm] = EIRP - 2.15 = E - 97.38$$

The respective calculated ERP of the spurious and harmonics were compared with the ERP of fundamental frequency by specified attenuation limits, $43+10\log_{10}(TP \text{ in watt})[dB]$. Where, TP = Transmitter power at the ANT OUT under test configuration as the hands free unit used.

Radiated Emission 30 MHz to 1000 MHz

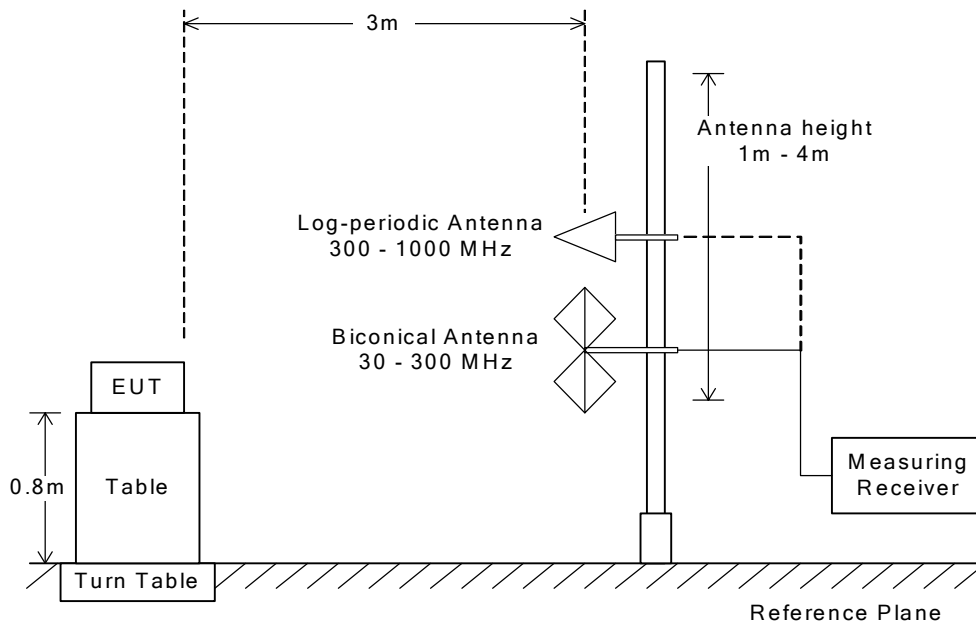

Radiated Emission above 1 GHz

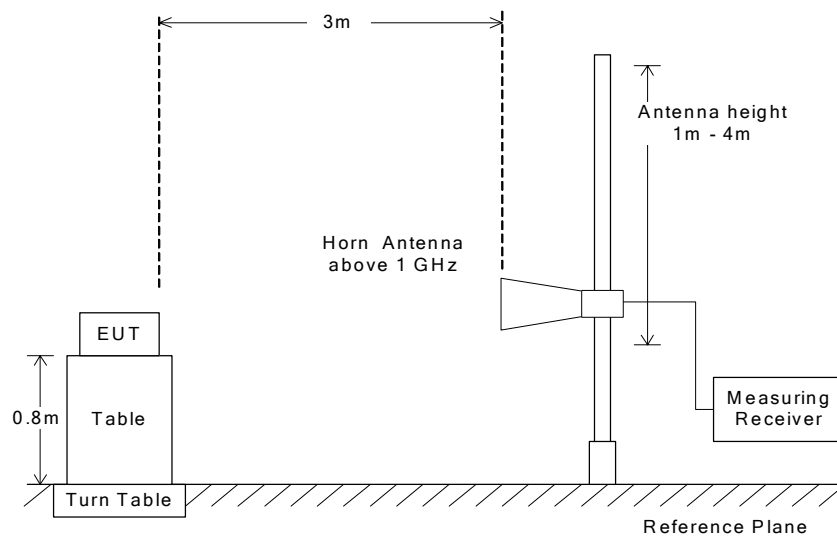
**NOTE**

The antenna height is scanned depending on the EUT's size and mounting height.

Radiated Emission 30 to 1000 MHz – Substitution Method

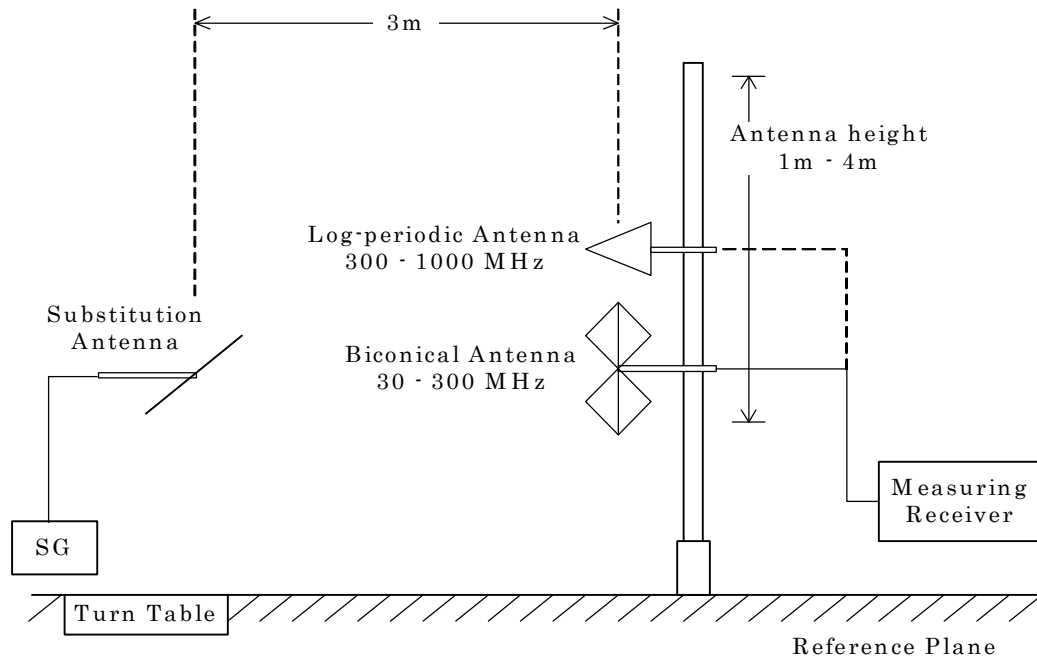

7.7.4 Test Data

a) Main Antenna

1) BW 5MHz(1RB)

(LTE 5MHz)

Test Configuration : Single Unit

Test Date: March 20, 2015
Temp.: 21 °C, Humi: 51 %

CH	Transmitting Frequency [MHz]	Measured Frequency [MHz]	ERP [dBm]		Limits [dBm]	Margin [dB]	Remarks
			Hori.	Vert.			
23755	706.500	1413.000	< -56.4	< -56.4	-13.0	> +43.4	C
		2119.500	< -56.5	< -56.5	-13.0	> +43.5	C
		2826.000	< -55.9	< -55.9	-13.0	> +42.9	C
		3532.500	< -54.7	< -54.7	-13.0	> +41.7	C
		4239.000	< -48.8	< -48.8	-13.0	> +35.8	C
		4945.500	< -48.0	< -48.0	-13.0	> +35.0	C
		5652.000	< -47.6	< -47.6	-13.0	> +34.6	C
		6358.500	< -45.5	< -45.5	-13.0	> +32.5	C
		7065.000	< -45.9	< -45.9	-13.0	> +32.9	C
23790	710.000	1420.000	< -56.5	< -56.5	-13.0	> +43.5	C
		2130.000	< -56.5	< -56.5	-13.0	> +43.5	C
		2840.000	< -55.9	< -55.9	-13.0	> +42.9	C
		3550.000	< -54.7	< -54.7	-13.0	> +41.7	C
		4260.000	< -48.7	< -48.7	-13.0	> +35.7	C
		4970.000	< -47.9	< -47.9	-13.0	> +34.9	C
		5680.000	< -47.6	< -47.6	-13.0	> +34.6	C
		6390.000	< -45.5	< -45.5	-13.0	> +32.5	C
		7100.000	< -45.9	< -45.9	-13.0	> +32.9	C
23825	713.500	1427.000	< -56.6	< -56.6	-13.0	> +43.6	C
		2140.500	< -56.6	< -56.6	-13.0	> +43.6	C
		2854.000	< -55.9	< -55.9	-13.0	> +42.9	C
		3567.500	< -54.7	< -54.7	-13.0	> +41.7	C
		4281.000	< -48.8	< -48.8	-13.0	> +35.8	C
		4994.500	< -47.9	< -47.9	-13.0	> +34.9	C
		5708.000	< -47.6	< -47.6	-13.0	> +34.6	C
		6421.500	< -45.5	< -45.5	-13.0	> +32.5	C
		7135.000	< -45.8	< -45.8	-13.0	> +32.8	C

Calculated result at 6358.5 MHz, as the worst point shown on underline:
Minimum Margin: $-13.0 - (<-45.5) = >32.5$ (dB)

NOTES

1. Test Distance : 3 m
2. The spectrum was checked from 30 MHz to 10 GHz.
3. All emissions not reported were more than 20 dB below the applied limits.
4. Applied limits : -13.0 [dBm] = $10\log(TP[mW]) - (43 + 10\log(tp[W])) = 10\log(TP[mW]) - (43 + (10 \log(TP[mW]) - 30))$
where, $tp[W] = TP[mW] / 1000$: Transmitter power at antenna terminal
5. The symbol of "<" means "or less".
6. The symbol of ">" means "more than".
7. Setting of measuring instrument(s) :

	Detector Function	RES B.W.	V.B.W.	Sweep Time
A	Peak	10 kHz	30 kHz	20 msec.
B	Peak	100 kHz	300 kHz	20 msec.
C	Peak	1 MHz	3 MHz	20 msec.

2) BW 10MHz(1RB)

(LTE 10MHz)

Test Date: March 20, 2015

Temp: 21 °C, Humi: 51 %

Test Configuration : Single Unit

CH	Transmitting Frequency [MHz]	Measured Frequency [MHz]	ERP [dBm]		Limits [dBm]	Margin [dB]	Remarks
			Hori.	Vert.			
23780	709.000	1418.000	< -56.4	< -56.4	-13.0	> +43.4	C
		2127.000	< -56.5	< -56.5	-13.0	> +43.5	C
		2836.000	< -55.9	< -55.9	-13.0	> +42.9	C
		3545.000	< -54.7	< -54.7	-13.0	> +41.7	C
		4254.000	< -48.7	< -48.7	-13.0	> +35.7	C
		4963.000	< -47.9	< -47.9	-13.0	> +34.9	C
		5672.000	< -47.6	< -47.6	-13.0	> +34.6	C
		6381.000	< -45.5	< -45.5	-13.0	> +32.5	C
		7090.000	< -45.9	< -45.9	-13.0	> +32.9	C
23790	710.000	1420.000	< -56.5	< -56.5	-13.0	> +43.5	C
		2130.000	< -56.5	< -56.5	-13.0	> +43.5	C
		2840.000	< -55.9	< -55.9	-13.0	> +42.9	C
		3550.000	< -54.7	< -54.7	-13.0	> +41.7	C
		4260.000	< -48.7	< -48.7	-13.0	> +35.7	C
		4970.000	< -47.9	< -47.9	-13.0	> +34.9	C
		5680.000	< -47.6	< -47.6	-13.0	> +34.6	C
		6390.000	< -45.5	< -45.5	-13.0	> +32.5	C
		7100.000	< -45.9	< -45.9	-13.0	> +32.9	C
23800	711.000	1422.000	< -56.5	< -56.5	-13.0	> +43.5	C
		2133.000	< -56.5	< -56.5	-13.0	> +43.5	C
		2844.000	< -55.9	< -55.9	-13.0	> +42.9	C
		3555.000	< -54.7	< -54.7	-13.0	> +41.7	C
		4266.000	< -48.8	< -48.8	-13.0	> +35.8	C
		4977.000	< -47.9	< -47.9	-13.0	> +34.9	C
		5688.000	< -47.6	< -47.6	-13.0	> +34.6	C
		6399.000	< -45.5	< -45.5	-13.0	> +32.5	C
		7110.000	< -45.8	< -45.8	-13.0	> +32.8	C

Calculated result at 6381.0 MHz, as the worst point shown on underline:
 Minimum Margin: -13.0 - (<45.5) = >32.5 (dB)

NOTES

1. Test Distance : 3 m
2. The spectrum was checked from 30 MHz to 10 GHz.
3. All emissions not reported were more than 20 dB below the applied limits.
4. Applied limits : -13.0 [dBm] = $10\log(TP[mW]) - (43 + 10\log(tp[W])) = 10\log(TP[mW]) - (43 + (10\log(TP[mW]) - 30))$
 where, $tp[W] = TP[mW] / 1000$: Transmitter power at antenna terminal
5. The symbol of "<" means "or less".
6. The symbol of ">" means "more than".
7. Setting of measuring instrument(s) :

	Detector Function	RES B.W.	V.B.W.	Sweep Time
A	Peak	10 kHz	30 kHz	20 msec.
B	Peak	100 kHz	300 kHz	20 msec.
C	Peak	1 MHz	3 MHz	20 msec.

b) Sub Antenna

1) BW 5MHz(1RB)

(LTE 5MHz)

Test Configuration : Single Unit

Test Date: March 20, 2015

Temp.: 21 °C, Humi: 51 %

CH	Transmitting Frequency [MHz]	Measured Frequency [MHz]	ERP [dBm]		Limits [dBm]	Margin [dB]	Remarks
			Hori.	Vert.			
23755	706.500	1413.000	< -56.4	< -56.4	-13.0	> +43.4	C
		2119.500	< -56.5	< -56.5	-13.0	> +43.5	C
		2826.000	< -55.9	< -55.9	-13.0	> +42.9	C
		3532.500	< -54.7	< -54.7	-13.0	> +41.7	C
		4239.000	< -48.8	< -48.8	-13.0	> +35.8	C
		4945.500	< -48.0	< -48.0	-13.0	> +35.0	C
		5652.000	< -47.6	< -47.6	-13.0	> +34.6	C
		6358.500	< -45.5	< -45.5	-13.0	> +32.5	C
		7065.000	< -45.9	< -45.9	-13.0	> +32.9	C
23790	710.000	1420.000	< -56.5	< -56.5	-13.0	> +43.5	C
		2130.000	< -56.5	< -56.5	-13.0	> +43.5	C
		2840.000	< -55.9	< -55.9	-13.0	> +42.9	C
		3550.000	< -54.7	< -54.7	-13.0	> +41.7	C
		4260.000	< -48.7	< -48.7	-13.0	> +35.7	C
		4970.000	< -47.9	< -47.9	-13.0	> +34.9	C
		5680.000	< -47.6	< -47.6	-13.0	> +34.6	C
		6390.000	< -45.5	< -45.5	-13.0	> +32.5	C
		7100.000	< -45.9	< -45.9	-13.0	> +32.9	C
23825	713.500	1427.000	< -56.6	< -56.6	-13.0	> +43.6	C
		2140.500	< -56.6	< -56.6	-13.0	> +43.6	C
		2854.000	< -55.9	< -55.9	-13.0	> +42.9	C
		3567.500	< -54.7	< -54.7	-13.0	> +41.7	C
		4281.000	< -48.8	< -48.8	-13.0	> +35.8	C
		4994.500	< -47.9	< -47.9	-13.0	> +34.9	C
		5708.000	< -47.6	< -47.6	-13.0	> +34.6	C
		6421.500	< -45.5	< -45.5	-13.0	> +32.5	C
		7135.000	< -45.8	< -45.8	-13.0	> +32.8	C

Calculated result at 6358.5 MHz, as the worst point shown on underline:
 Minimum Margin: $-13.0 - (<-45.5) = >32.5$ (dB)

NOTES

1. Test Distance : 3 m
2. The spectrum was checked from 30 MHz to 10 GHz.
3. All emissions not reported were more than 20 dB below the applied limits.
4. Applied limits : -13.0 [dBm] = $10\log(TP[mW]) - (43 + 10\log(tp[W])) = 10\log(TP[mW]) - (43 + (10 \log(TP[mW]) - 30))$
 where, $tp[W] = TP[mW] / 1000$: Transmitter power at antenna terminal
5. The symbol of "<" means "or less".
6. The symbol of ">" means "more than".
7. Setting of measuring instrument(s) :

	Detector Function	RES B.W.	V.B.W.	Sweep Time
A	Peak	10 kHz	30 kHz	20 msec.
B	Peak	100 kHz	300 kHz	20 msec.
C	Peak	1 MHz	3 MHz	20 msec.

2) BW 10MHz(1RB)

(LTE 10MHz)

Test Date: March 20, 2015

Temp: 21 °C, Humi: 51 %

Test Configuration : Single Unit

CH	Transmitting Frequency [MHz]	Measured Frequency [MHz]	ERP [dBm]		Limits [dBm]	Margin [dB]	Remarks
			Hori.	Vert.			
23780	709.000	1418.000	< -56.4	< -56.4	-13.0	> +43.4	C
		2127.000	< -56.5	< -56.5	-13.0	> +43.5	C
		2836.000	< -55.9	< -55.9	-13.0	> +42.9	C
		3545.000	< -54.7	< -54.7	-13.0	> +41.7	C
		4254.000	< -48.7	< -48.7	-13.0	> +35.7	C
		4963.000	< -47.9	< -47.9	-13.0	> +34.9	C
		5672.000	< -47.6	< -47.6	-13.0	> +34.6	C
		6381.000	< -45.5	< -45.5	-13.0	> +32.5	C
		7090.000	< -45.9	< -45.9	-13.0	> +32.9	C
23790	710.000	1420.000	< -56.5	< -56.5	-13.0	> +43.5	C
		2130.000	< -56.5	< -56.5	-13.0	> +43.5	C
		2840.000	< -55.9	< -55.9	-13.0	> +42.9	C
		3550.000	< -54.7	< -54.7	-13.0	> +41.7	C
		4260.000	< -48.7	< -48.7	-13.0	> +35.7	C
		4970.000	< -47.9	< -47.9	-13.0	> +34.9	C
		5680.000	< -47.6	< -47.6	-13.0	> +34.6	C
		6390.000	< -45.5	< -45.5	-13.0	> +32.5	C
		7100.000	< -45.9	< -45.9	-13.0	> +32.9	C
23800	711.000	1422.000	< -56.5	< -56.5	-13.0	> +43.5	C
		2133.000	< -56.5	< -56.5	-13.0	> +43.5	C
		2844.000	< -55.9	< -55.9	-13.0	> +42.9	C
		3555.000	< -54.7	< -54.7	-13.0	> +41.7	C
		4266.000	< -48.8	< -48.8	-13.0	> +35.8	C
		4977.000	< -47.9	< -47.9	-13.0	> +34.9	C
		5688.000	< -47.6	< -47.6	-13.0	> +34.6	C
		6399.000	< -45.5	< -45.5	-13.0	> +32.5	C
		7110.000	< -45.8	< -45.8	-13.0	> +32.8	C

Calculated result at 6381.0 MHz, as the worst point shown on underline:
 Minimum Margin: -13.0 - (<45.5) = >32.5 (dB)

NOTES

1. Test Distance : 3 m
2. The spectrum was checked from 30 MHz to 10 GHz.
3. All emissions not reported were more than 20 dB below the applied limits.
4. Applied limits : -13.0 [dBm] = $10\log(TP[mW]) - (43 + 10\log(tp[W])) = 10\log(TP[mW]) - (43 + (10 \log(TP[mW]) - 30))$
 where, $tp[W] = TP[mW] / 1000$: Transmitter power at antenna terminal
5. The symbol of "<" means "or less".
6. The symbol of ">" means "more than".
7. Setting of measuring instrument(s) :

	Detector Function	RES B.W.	V.B.W.	Sweep Time
A	Peak	10 kHz	30 kHz	20 msec.
B	Peak	100 kHz	300 kHz	20 msec.
C	Peak	1 MHz	3 MHz	20 msec.

7.8 Frequency Stability(\$2.1055)

For the requirements, - Applicable - Tested. - Not tested by applicant request.]
 - Not Applicable

For the limits, - Passed - Failed - Not judged

7.8.1 Worst Point and Measurement Uncertainty

The Frequency Stability level is +/-0.01 ppm at 710.000 MHz

Uncertainty of Measurement Results +/-0.03 ppm(2σ)

Remarks : _____

7.8.2 Test Site and Instruments

7.8.2.1 Test Site

KITA-KANSAI Testing Center

Test site : SAITO - Measurement room (M4) - Shielded room (S4)
 MINOH - Environment Testing Room

7.8.2.2 Test Instruments

Type	Model	Manufacturer	ID No.	Last Cal.	Interval
Radio Communication Analyzer	MT8820C	Anritsu	B-5	2015/3	1 Year
DC Voltage Meter	2011-39	YEW	B-33	2014/6	1 Year
Environmental Chamber	SH-641	ESPEC	F-32	2014/7	1 Year
DC Power Supply	NL035-10	TAKASAGO	F-4	N/A	N/A

7.8.3 Test Method and Test Setup (Diagrammatic illustration)

Frequency Stability versus Temperature

The EUT was placed in an environmental chamber and was tested in the range from -30 to +50 degrees Celsius. The EUT was stabilized at each temperature. The power (4.0VDC) supplied was applied to the transmitter and allowed to stabilize for 10 minutes. The transmitting frequency was measured at startup and 2 minutes, 5 minutes and 10 minutes after startup. This procedure was repeated from -30 to +50 degrees Celsius at the interval of 10 degrees.

Frequency Stability versus Power Supply Voltage

The EUT was placed in an environmental chamber and was tested at the temperature of +20 degrees Celsius. The EUT was stabilized at the temperature. The power (4.0VDC) and the power (3.7VDC, the ending voltage) was applied to the EUT allowed to stabilize for 10 minutes. The transmitting frequency was measured at startup and 2 minutes, 5 minutes and 10 minutes after startup.

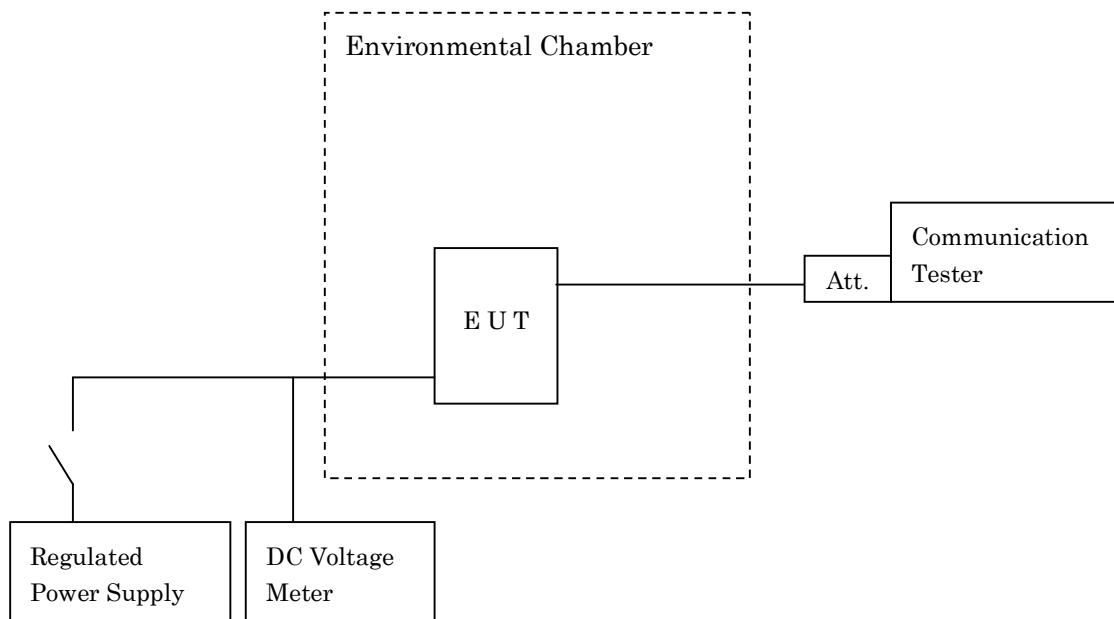

7.8.4 Test Data

(LTE)

Test Date: March 25, 2015
- March 26, 2015

1. Frequency Stability Measurement versus Temperature

Transmitting Frequency : 710.000 MHz (23790 ch)
 DC Supply Voltage : 4.0 VDC

Ambient Temperature [°C]	Startup	Deviation [ppm]			Limits [ppm]	Margin [ppm]
		2 minutes	5 minutes	10 minutes		
-30	<u>- 0.01</u>	<u>- 0.01</u>	<u>- 0.01</u>	<u>- 0.01</u>	N/A	N/A
-20	<u>- 0.01</u>	<u>+ 0.01</u>	<u>+ 0.01</u>	<u>- 0.01</u>	N/A	N/A
-10	<u>+ 0.01</u>	<u>- 0.01</u>	+ 0.00	+ 0.00	N/A	N/A
0	<u>- 0.01</u>	<u>- 0.01</u>	<u>- 0.01</u>	<u>- 0.01</u>	N/A	N/A
10	<u>+ 0.01</u>	<u>+ 0.01</u>	<u>+ 0.01</u>	<u>+ 0.01</u>	N/A	N/A
20	<u>+ 0.01</u>	<u>+ 0.01</u>	<u>+ 0.01</u>	+ 0.00	N/A	N/A
30	+ 0.00	+ 0.00	+ 0.00	+ 0.00	N/A	N/A
40	<u>+ 0.01</u>	+ 0.00	+ 0.00	+ 0.00	N/A	N/A
50	+ 0.00	+ 0.00	+ 0.00	+ 0.00	N/A	N/A

2. Frequency Stability Measurement versus Power Supply Voltage

Transmitting Frequency : 710.000 MHz (23790 ch)
 Ambient Temperature : 20 °C

DC Supply Voltage [V]	Startup	Deviation [ppm]			Limits [ppm]	Margin [ppm]
		2 minutes	5 minutes	10 minutes		
4.0	<u>+ 0.01</u>	<u>+ 0.01</u>	<u>+ 0.01</u>	+ 0.00	N/A	N/A
3.7 (Ending)	<u>+ 0.01</u>	<u>+ 0.01</u>	<u>+ 0.01</u>	+ 0.00	N/A	N/A

Test condition example as the maximum deviation point shown on underline:

Ambient Temperature : -30 °C / Startup
 DC Supply Voltage : 4 VDC

NOTE : The measurement were made after all of components of the oscillator sufficiently stabilized at each temperature.