



RADIO TEST REPORT

Report No.: STS2002026W10

Issued for

DTEN Inc

97 E. Brokaw Road, Suite 180, San Jose, CA 95112

Product Name:	DTEN ON
Brand Name:	DTEN
Model Name:	DBA0455
Series Model:	N/A
FCC ID:	2AQ7Q-DBA0455
Test Standard:	FCC Part 15.407

Any reproduction of this document must be done in full. No single part of this document may be reproduced without permission from STS, All Test Data Presented in this report is only applicable to presented Test sample.

Shenzhen STS Test Services Co., Ltd.
A 1/F, Building B, Zhuoke Science Park, No.190 Chongqing Road, HepingShequ,
Fuyong Sub-District, Bao'an District, Shenzhen, Guang Dong, China
TEL: +86-755 3688 6288 FAX: +86-755 3688 6277 E-mail: sts@stsapp.com





TEST RESULT CERTIFICATION

Applicant's Name..... : DTEN Inc
 Address : 97 E. Brokaw Road, Suite180, San Jose, CA 95112
Manufacture's Name..... : DTEN Inc
 Address : 97 E. Brokaw Road, Suite180, San Jose, CA 95112

Product Description

Product Name..... : DTEN ON
 Brand Name : DTEN
 Model Name : DBA0455
 Series Model..... : N/A

Test Standards : FCC Part15.407

Test Procedure..... ANSI C63.10-2013

This device described above has been tested by STS, the test results show that the equipment under test (EUT) is in compliance with the FCC requirements. And it is applicable only to the tested sample identified in the report.

This report shall not be reproduced except in full, without the written approval of STS, this document only be altered or revised by STS, personal only, and shall be noted in the revision of the document.

Date of Test..... :
 Date of receipt of test item : 16 Mar. 2020
 Date (s) of performance of tests : 16 Mar. 2020 ~ 29 Apr. 2020
 Date of Issue..... : 06 May. 2020
 Test Result..... : **Pass**

Testing Engineer : *Chris Chen*
 (Chris Chen)

Technical Manager : *Sean She*
 (Sean she)

Authorized Signatory : *Vita Li*
 (Vita Li)

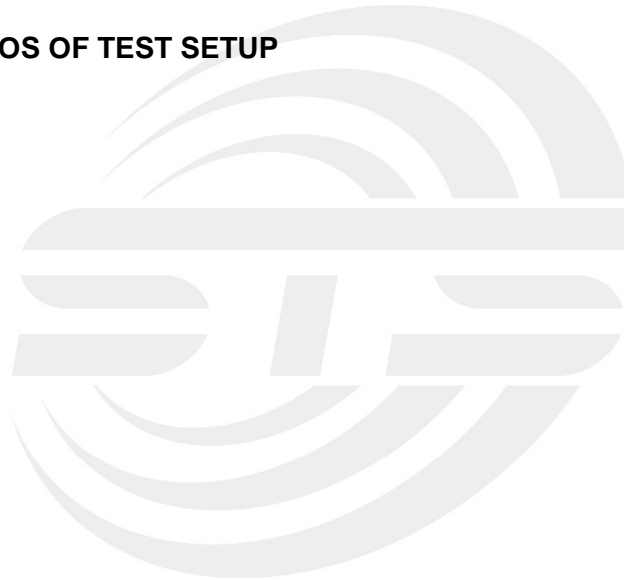



Table of Contents	Page
1 . SUMMARY OF TEST RESULTS	6
1.1 TEST FACTORY	7
1.2 MEASUREMENT UNCERTAINTY	7
2 . GENERAL INFORMATION	8
2.1 GENERAL DESCRIPTION OF THE EUT	8
2.2 DESCRIPTION OF TEST MODES	12
2.3 TEST SOFTWARE AND POWER LEVEL	13
2.4 BLOCK DIGRAM SHOWING THE CONFIGURATION OF SYSTEM TESTED	14
2.5 DESCRIPTION OF NECESSARY ACCESSORIES AND SUPPORT UNITS	15
2.6 EQUIPMENTS LIST FOR ALL TEST ITEMS	16
3 . EMC EMISSION TEST	17
3.1 CONDUCTED EMISSION MEASUREMENT	17
3.2 RADIATED EMISSION AND (BANDEGE) MEASUREMENT	21
4. CONDUCTED SPURIOUS EMISSIONS AND BANDEGE	41
4.1 LIMIT	41
4.2 TEST PROCEDURE	41
4.3 DEVIATION FROM STANDARD	41
4.4 TEST SETUP	42
4.5 EUT OPERATION CONDITIONS	42
4.6 TEST RESULTS	42
5. POWER SPECTRAL DENSITY TEST	43
5.1 LIMIT	43
5.2 TEST PROCEDURE	43
5.3 DEVIATION FROM STANDARD	44
5.4 TEST SETUP	44
5.5 EUT OPERATION CONDITIONS	44
5.6 TEST RESULTS	44
6. BANDWIDTH MEASUREMENT	48
6.1 EMISSION BANDWIDTH (EBW) 26 BANDWID PROCEDURES / LIMIT	48
6.2 OCCUPIED BANDWIDTH (99%) TEST APPLIED PROCEDURES / LIMIT	51
6.3 MINIMUM EMISSION BANDWIDTH(6 DB) PROCEDURES / LIMIT	54
7. MAXIMUM CONDUCTED OUTPUT POWER	56
7.1 LIMIT	56
7.2 TEST PROCEDURE	56



Table of Contents	Page
7.3 DEVIATION FROM STANDARD	56
7.4 TEST SETUP	56
7.5 EUT OPERATION CONDITIONS	56
7.6 TEST RESULTS	57
8. AUTOMATICALLY DISCONTINUE TRANSMISSION	67
8.1 LIMIT OF AUTOMATICALLY DISCONTINUE TRANSMISSION	67
8.2 TEST RESULT OF AUTOMATICALLY DISCONTINUE TRANSMISSION	67
9. ANTENNA REQUIREMENT	68
9.1 STANDARD REQUIREMENT	68
9.2 EUT ANTENNA	68
APPENDIX - PHOTOS OF TEST SETUP	69





Revision History

Rev.	Issue Date	Report NO.	Effect Page	Contents
00	06 May. 2020	STS2002026W10	ALL	Initial Issue





1. SUMMARY OF TEST RESULTS

Test procedures according to the technical standards:

§ 15.407, KDB 789033 D02 General U-NII Test Procedures New Rules v02r01

FCC Part 15.407		
FCC standard	Test Item	Results
15.207	AC Conducted Emission	PASS
§ 15.407 (2) (26 dB) / § 15.407 (e) (6 dB) / § 15.407 (a) (99%)	26dB/6dB & 99% Bandwidth	PASS
15.407(a) (1).(2).(3).(4).(5)	Maximum Conducted Output Power	PASS
15.407(b) & 15.209	Radiated Emission And (bandedge Emissions) Measurement	PASS
15.407(b)7	Conducted Emission And (bandedge Emissions) Measurement	PASS
15.407(a) (1).(2).(3).(4).(5)	Power Spectral Density	PASS
15.407(c)	Automatically Discontinue Transmission	PASS
15.203/15.204	Antenna Requirement	PASS

NOTE:

- (1) 'N/A' denotes test is not applicable in this Test Report.
- (2) All tests are according to ANSI C63.10-2013.



1.1 TEST FACTORY

SHENZHEN STS TEST SERVICES CO., LTD

Add. : A 1/F, Building B, Zhuoke Science Park, No.190 Chongqing Road, HepingShequ, Fuyong Sub-District, Bao'an District, Shenzhen, Guang Dong, China

FCC test Firm Registration Number: 625569

IC test Firm Registration Number: 12108A

A2LA Certificate No.: 4338.01

1.2 MEASUREMENT UNCERTAINTY

The reported uncertainty of measurement $y \pm U$, where expanded uncertainty U is based on a standard uncertainty multiplied by a coverage factor of $k=2$, providing a level of confidence of approximately **95 %**.

No.	Item	Uncertainty
1	RF output power, conducted	$\pm 0.68\text{dB}$
2	Unwanted Emissions, conducted	$\pm 2.988\text{dB}$
3	All emissions, radiated 30-1GHz	$\pm 6.7\text{dB}$
4	All emissions, radiated 1G-6GHz	$\pm 5.5\text{dB}$
5	All emissions, radiated >6G	$\pm 5.8\text{dB}$
6	Conducted Emission (9KHz-150KHz)	$\pm 4.43\text{dB}$
7	Conducted Emission (150KHz-30MHz)	$\pm 5\text{dB}$



2. GENERAL INFORMATION

2.1 GENERAL DESCRIPTION OF THE EUT

Product Name	DTEN ON																																				
Trade Name	DTEN																																				
Model Name	DBA0455																																				
Series Model	N/A																																				
Model Difference	N/A																																				
Product Description	<p>The EUT is a DTEN ON</p> <table border="1"> <tr> <td>Operation Frequency:</td> <td> IEEE 802.11a/ n(HT20)/ac(VHT20): 5.180GHz-5.240GHz IEEE 802.11n(HT40)/ac(VHT40): 5.190GHz-5.230GHz IEEE 802.11ac(VHT80): 5.210GHz IEEE 802.11a/ n(HT20)/ac(VHT20): 5.260GHz-5.320GHz IEEE 802.11 n(HT40)/ac(VHT40): 5.270GHz-5.310GHz IEEE 802.11ac(VHT80): 5.290GHz IEEE 802.11a/ n(HT20)/ac(VHT20): 5.500GHz-5.700GHz IEEE 802.11 n(HT40)/ac(VHT40): 5.510GHz-5.670GHz IEEE 802.11ac(VHT80): 5.530GHz-5.610GHz IEEE 802.11a/ n(HT20)/ac(VHT20): 5.745GHz-5.825GHz IEEE 802.11a/ n(HT40)/ac(VHT40): 5.755GHz-5.795GHz IEEE 802.11ac(VHT80): 5.775GHz </td> </tr> <tr> <td>Modulation Type:</td> <td> 802.11a(OFDM): BPSK,QPSK,16-QAM,64-QAM 802.11n(OFDM): BPSK,QPSK,16-QAM,64-QAM 802.11ac(OFDM): BPSK,QPSK,16-QAM,64-QAM,256-QAM </td> </tr> <tr> <td>Antenna Designation:</td> <td>Please refer to the Note 3.</td> </tr> <tr> <td>Max.Output Power(Conducted):</td> <td>12.44 dBm</td> </tr> </table> <p>More details of EUT technical specification, please refer to the User Manual.</p>	Operation Frequency:	IEEE 802.11a/ n(HT20)/ac(VHT20): 5.180GHz-5.240GHz IEEE 802.11n(HT40)/ac(VHT40): 5.190GHz-5.230GHz IEEE 802.11ac(VHT80): 5.210GHz IEEE 802.11a/ n(HT20)/ac(VHT20): 5.260GHz-5.320GHz IEEE 802.11 n(HT40)/ac(VHT40): 5.270GHz-5.310GHz IEEE 802.11ac(VHT80): 5.290GHz IEEE 802.11a/ n(HT20)/ac(VHT20): 5.500GHz-5.700GHz IEEE 802.11 n(HT40)/ac(VHT40): 5.510GHz-5.670GHz IEEE 802.11ac(VHT80): 5.530GHz-5.610GHz IEEE 802.11a/ n(HT20)/ac(VHT20): 5.745GHz-5.825GHz IEEE 802.11a/ n(HT40)/ac(VHT40): 5.755GHz-5.795GHz IEEE 802.11ac(VHT80): 5.775GHz	Modulation Type:	802.11a(OFDM): BPSK,QPSK,16-QAM,64-QAM 802.11n(OFDM): BPSK,QPSK,16-QAM,64-QAM 802.11ac(OFDM): BPSK,QPSK,16-QAM,64-QAM,256-QAM	Antenna Designation:	Please refer to the Note 3.	Max.Output Power(Conducted):	12.44 dBm																												
Operation Frequency:	IEEE 802.11a/ n(HT20)/ac(VHT20): 5.180GHz-5.240GHz IEEE 802.11n(HT40)/ac(VHT40): 5.190GHz-5.230GHz IEEE 802.11ac(VHT80): 5.210GHz IEEE 802.11a/ n(HT20)/ac(VHT20): 5.260GHz-5.320GHz IEEE 802.11 n(HT40)/ac(VHT40): 5.270GHz-5.310GHz IEEE 802.11ac(VHT80): 5.290GHz IEEE 802.11a/ n(HT20)/ac(VHT20): 5.500GHz-5.700GHz IEEE 802.11 n(HT40)/ac(VHT40): 5.510GHz-5.670GHz IEEE 802.11ac(VHT80): 5.530GHz-5.610GHz IEEE 802.11a/ n(HT20)/ac(VHT20): 5.745GHz-5.825GHz IEEE 802.11a/ n(HT40)/ac(VHT40): 5.755GHz-5.795GHz IEEE 802.11ac(VHT80): 5.775GHz																																				
Modulation Type:	802.11a(OFDM): BPSK,QPSK,16-QAM,64-QAM 802.11n(OFDM): BPSK,QPSK,16-QAM,64-QAM 802.11ac(OFDM): BPSK,QPSK,16-QAM,64-QAM,256-QAM																																				
Antenna Designation:	Please refer to the Note 3.																																				
Max.Output Power(Conducted):	12.44 dBm																																				
Test Channel	Please refer to the Note 2.																																				
Adapter	<p>Input: 100-240V~ 50/60Hz 3.0A Output:</p> <p>2.2.1 Table 2 Constant Voltage Output Specification (恒压输出规格)</p> <table border="1"> <thead> <tr> <th>Output Channel 输出通道</th> <th>Output Rated Voltage 输出额定电压</th> <th>Voltage Regulation 电压调整率</th> <th>Min. current 最小电流</th> <th>Rated current 额定电流</th> <th>Peak current 峰值电流</th> </tr> </thead> <tbody> <tr> <td>STB</td> <td>+5V</td> <td>±5%</td> <td>0.03A</td> <td>1.0A</td> <td>2.0A</td> </tr> <tr> <td>V5</td> <td>+5V</td> <td>±5%</td> <td>0.1A</td> <td>2.5A</td> <td>3.0A</td> </tr> <tr> <td>V12</td> <td>+12V</td> <td>±10%</td> <td>0.1A</td> <td>3.0A</td> <td>4.0A</td> </tr> <tr> <td>V19</td> <td>+19V</td> <td>±10%</td> <td>0.1A</td> <td>5.0A</td> <td>6.5A</td> </tr> <tr> <td>V24</td> <td>+24V</td> <td>±10%</td> <td>0.1A</td> <td>1.0A</td> <td>1.2A</td> </tr> </tbody> </table>	Output Channel 输出通道	Output Rated Voltage 输出额定电压	Voltage Regulation 电压调整率	Min. current 最小电流	Rated current 额定电流	Peak current 峰值电流	STB	+5V	±5%	0.03A	1.0A	2.0A	V5	+5V	±5%	0.1A	2.5A	3.0A	V12	+12V	±10%	0.1A	3.0A	4.0A	V19	+19V	±10%	0.1A	5.0A	6.5A	V24	+24V	±10%	0.1A	1.0A	1.2A
Output Channel 输出通道	Output Rated Voltage 输出额定电压	Voltage Regulation 电压调整率	Min. current 最小电流	Rated current 额定电流	Peak current 峰值电流																																
STB	+5V	±5%	0.03A	1.0A	2.0A																																
V5	+5V	±5%	0.1A	2.5A	3.0A																																
V12	+12V	±10%	0.1A	3.0A	4.0A																																
V19	+19V	±10%	0.1A	5.0A	6.5A																																
V24	+24V	±10%	0.1A	1.0A	1.2A																																
Hardware version number	N/A																																				



Software version number	1.0.0.8
Connecting I/O Port(s)	Please refer to the Note 1.

Note

1. For a more detailed features description, please refer to the manufacturer's specifications or the User Manual.





2. Operation Frequency of channel

5.180GHz-5.240GHz		5.500GHz-5.720GHz	
Channel	Frequency	Channel	Frequency
36	5180	100	5500
38	5190	102	5510
40	5200	104	5520
42	5210	108	5540
44	5220	110	5550
46	5230	112	5560
48	5240	116	5580
		118	5590
		120	5600
5.260GHz-5.320GHz			
Channel	Frequency		
52	5260	124	5620
54	5270	126	5630
56	5280	128	5640
58	5290	132	5660
60	5300	134	5670
62	5310	136	5680
64	5320	140	5700
5.745GHz-5.825GHz			
Channel	Frequency		
149	5745		
151	5755		
153	5765		
157	5785		
159	5795		
161	5805		
165	5825		

Note:

In section 15.31(m), regards to the operating frequency range over 10 MHz, the Lowest frequency, the middle frequency, and the highest frequency of channel were selected to perform the test, and the selected channel see below:

Carrier Frequency Channel

5GHz:

For 802.11a/n(HT20)/ac(VHT20)			
Channel	Freq.(MHz)	Channel	Freq.(MHz)
36	5180	52	5260
40	5200	60	5300
48	5240	64	5320

For 802.11a/n(HT20)/ac(VHT20)			
Channel	Freq.(MHz)	Channel	Freq.(MHz)
100	5500	149	5745
116	5580	157	5785
140	5700	165	5825



For 802.11 n(HT40)/ac(VHT40)			
Channel	Freq.(MHz)	Channel	Freq.(MHz)
38	5190	54	5270
46	5230	62	5310

For 802.11 n(HT40)/ac(VHT40)			
Channel	Freq.(MHz)	Channel	Freq.(MHz)
102	5510	151	5755
110	5550	159	5795
134	5670		

For 802.11ac (VHT80)			
Channel	Freq.(MHz)	Channel	Freq.(MHz)
42	5210	58	5290

For 802.11ac (VHT80)			
Channel	Freq.(MHz)	Channel	Freq.(MHz)
106	5530	155	5775
122	5610		

3. KDB 662911 D01 Multiple Transmitter Output v02r01

2) Directional Gain Calculations for In-Band Measurements

a) Basic methodology with NANT transmit antennas, each with the same directional gain GANT dBi, being driven by NANT transmitter outputs of equal power. Directional gain is to be computed as follows:

- (i) If any transmit signals are correlated with each other,
Directional gain = GANT + 10 log(NANT) dBi
- (ii) If all transmit signals are completely uncorrelated with each other,
Directional gain = GANT

Antenna number: 2Antenna A gain : 2.5dBiAntenna B gain : 2.5dBiMIMO technology
Directional gain=5.51dBi

$GANT + 10 \log(NANT) \text{ dBi}$
 $\{ \text{Directional gain} \} \text{dBi}$

Ant	Brand	Model Name	Ant Type	Connector	Gain (dBi)	NOTE
A	DTEN	DBA0455	PIFA Antenna	N/A	Antenna number: 2Antenna A gain : 2.5dBiAntenna B gain : 2.5dBiMIMO technology Directional gain=5.51dBi	WLAN Ant



2.2 DESCRIPTION OF TEST MODES

To investigate the maximum EMI emission characteristics generated from EUT, the test system was pre-scanning tested based on the consideration of following EUT operation mode or test configuration mode which possibly have effect on EMI emission level. Each of these EUT operation mode(s) or test configuration mode(s) mentioned above was evaluated respectively.

Worst Mode	Description	Data Rate
Mode 1	TX IEEE 802.11a HT20 CH36&CH40&CH48	6 Mbps
Mode 2	TX IEEE 802.11a HT20 CH52&CH60&CH64	6 Mbps
Mode 3	TX IEEE 802.11a HT20 CH100&CH116&CH140	6 Mbps
Mode 4	TX IEEE 802.11a HT20 CH149&CH157&CH165	6 Mbps
Mode 5	TX IEEE 802.11n HT20 CH36&CH40&CH48	MCS 0
Mode 6	TX IEEE 802.11ac HT20 CH36&CH40&CH48	NSS1 MCS0
Mode 7	TX IEEE 802.11n HT20 CH52&CH60&CH64	MCS 0
Mode 8	TX IEEE 802.11ac HT20 CH52&CH60&CH64	NSS1 MCS0
Mode 9	TX IEEE 802.11n HT20 CH100&CH116&CH140	MCS 0
Mode 10	TX IEEE 802.11ac HT20 CH100&CH116&CH140	NSS1 MCS0
Mode 11	TX IEEE 802.11n HT20 CH149&CH157&CH165	MCS 0
Mode 12	TX IEEE 802.11ac HT20 CH149&CH157&CH165	NSS1 MCS0
Mode 13	TX IEEE 802.11n HT40 CH38&CH46	MCS 0
Mode 14	TX IEEE 802.11ac HT40 CH38&CH46	NSS1 MCS0
Mode 15	TX IEEE 802.11n HT40 CH54 &CH62	MCS 0
Mode 16	TX IEEE 802.11ac HT40 CH54 &CH62	NSS1 MCS0
Mode 17	TX IEEE 802.11n HT40 CH102&CH110&CH134	MCS 0
Mode 18	TX IEEE 802.11ac HT40 CH102&CH110&CH134	NSS1 MCS0
Mode 19	TX IEEE 802.11n HT40 CH151&CH159	MCS 0
Mode 20	TX IEEE 802.11ac HT40 CH151&CH159	NSS1 MCS0
Mode 21	TX IEEE 802.11ac HT80 CH42	NSS1 MCS0
Mode 22	TX IEEE 802.11ac HT80 CH58	NSS1 MCS0
Mode 23	TX IEEE 802.11ac HT80 CH106&122	NSS1 MCS0
Mode 24	TX IEEE 802.11ac HT80 CH155	NSS1 MCS0

- Note: (1) The measurements are performed at the highest, middle, lowest available channels.
(2) The measurements are performed at all Bit Rate of Transmitter, the worst data was reported.
(3) We have been tested for all available U.S. voltage and frequencies (For 120V, 50/60Hz and 240V, 50/60Hz) for which the device is capable of operation.



AC Conducted Emission

Test Case	
AC Conducted Emission	Mode 25: Keeping TX + WLAN Link

2.3 TEST SOFTWARE AND POWER LEVEL

During testing channel & power controlling software provided by the customer was used to control the operating channel as well as the output power level.

RF Function	Type	Mode Or Modulation type	Ant Gain(dBi)	Power Class	Software For Testing
WIFI(5G)	5G WIFI Band1 (5150MHz-5250MHz)	802.11a	Ant A: 2.5 Ant B: 2.5	13	ADB command
		802.11n(HT20)		10	
		802.11n(HT20)		10	
		802.11ac(VHT20)		10	
		802.11ac(VHT40)		10	
		802.11ac(VHT80)		10	
	5G WIFI Band2 (5250MHz-5350MHz)	802.11a	Ant A: 2.5 Ant B: 2.5	13	
		802.11n(HT20)		10	
		802.11n(HT20)		10	
		802.11ac(VHT20)		10	
		802.11ac(VHT40)		10	
		802.11ac(VHT80)		10	
	5G WIFI Band3 (5470MHz-5725MHz)	802.11a	Ant A: 2.5 Ant B: 2.5	13	
		802.11n(HT20)		10	
		802.11n(HT20)		10	
		802.11ac(VHT20)		10	
		802.11ac(VHT40)		10	
		802.11ac(VHT80)		10	
	5G WIFI Band4 (5725MHz-5875MHz)	802.11a	Ant A: 2.5 Ant B: 2.5	10	
		802.11n(HT20)		7	
		802.11n(HT20)		7	
		802.11ac(VHT20)		7	
		802.11ac(VHT40)		7	
		802.11ac(VHT80)		7	

2.4 BLOCK DIGRAM SHOWING THE CONFIGURATION OF SYSTEM TESTED

Radiated Spurious Emission Test

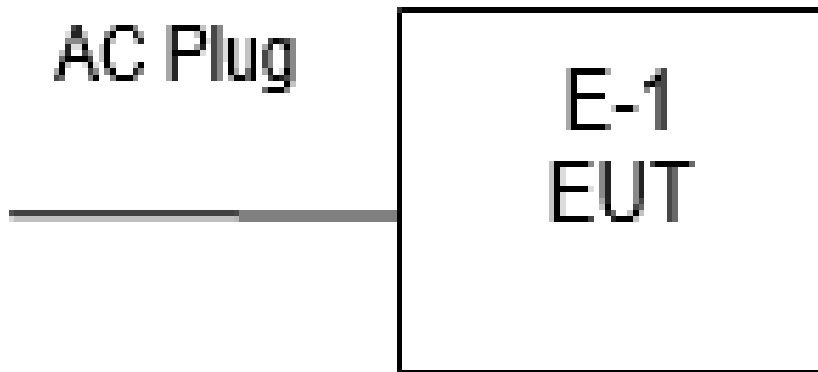

Conducted Emission Test

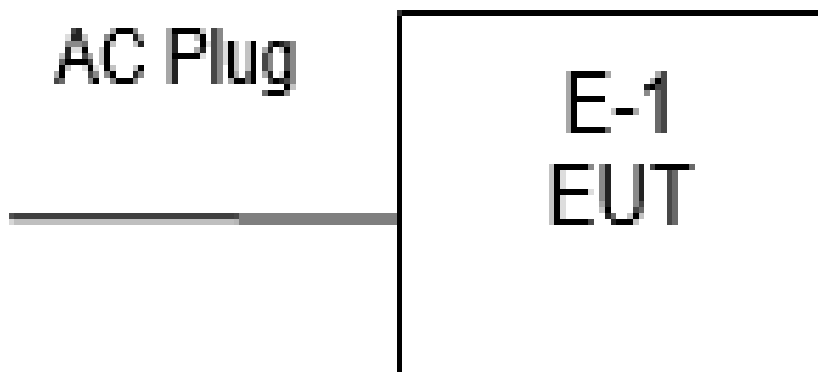



2.5 DESCRIPTION OF NECESSARY ACCESSORIES AND SUPPORT UNITS

The EUT has been tested as an independent unit together with other necessary accessories or support units. The following support units or accessories were used to form a representative test configuration during the tests.

Necessary accessories

Item	Equipment	Mfr/Brand	Model/Type No.	Serial No.	Note
N/A	N/A	N/A	N/A	N/A	N/A

Support units

Item	Equipment	Mfr/Brand	Model/Type No.	Serial No.	Note
N/A	N/A	N/A	N/A	N/A	N/A

Note:

- (1) The support equipment was authorized by Declaration of Confirmation.
- (2) For detachable type I/O cable should be specified the length in cm in 『Length』 column.



2.6 EQUIPMENTS LIST FOR ALL TEST ITEMS

Radiation Test equipment

Kind of Equipment	Manufacturer	Type No.	Serial No.	Last calibration	Calibrated until
EMI Test Receiver	R&S	ESCI	101427	2019.07.29	2020.07.28
Signal Analyzer	Agilent	N9020A	MY51110105	2020.03.05	2021.03.04
Active loop Antenna	ZHINAN	ZN30900C	16035	2018.03.11	2021.03.10
Bilog Antenna	TESEQ	CBL6111D	34678	2017.11.02	2020.11.01
Horn Antenna	SCHWARZBECK	BBHA 9120D(1201)	9120D-1343	2018.10.19	2021.10.18
Horn Antenna (18-40GHz)	A-INFO	LB-180400-KF	J211020657	2018.03.11	2021.03.10
Spectrum Analyzer	R&S	FSV40-N	101823	2019.06.05	2020.06.04
Pre-Amplifier(0.1 M-3GHz)	EM	EM330	060665	2019.10.09	2020.10.08
Pre-Amplifier (1G-18GHz)	SKET	LNPA-01018G-45	SK2018080901	2019.10.12	2020.10.11
Pre-mpifier (18G-40G)	SKET	LNPA_1840-50	SK2018101801	2019.10.22	2020.10.21
Temperature & Humidity	HH660	Mieo	N/A	2019.10.12	2020.10.11
Turn table	EM	SC100_1	60531	N/A	N/A
Antenna mast	EM	SC100	N/A	N/A	N/A
Test SW	BULUN	BL410-E/18.905			

Conduction Test equipment

Kind of Equipment	Manufacturer	Type No.	Serial No.	Last calibration	Calibrated until
Test Receiver	R&S	ESCI	101427	2019.07.29	2020.07.28
LISN	R&S	ENV216	101242	2019.10.09	2020.10.08
LISN	EMCO	3810/2NM	23625	2019.10.09	2020.10.08
Temperature & Humidity	HH660	Mieo	N/A	2019.10.12	2020.10.11
Test SW	FARAD	EZ-EMC(Ver.STSLAB-03A1 CE)			

RF Connected Test

Kind of Equipment	Manufacturer	Type No.	Serial No.	Last calibration	Calibrated until
USB RF power sensor	DARE	RPR3006W	15I00041SNO03	2019.10.09	2020.10.08
Signal Analyzer	Agilent	N9020A	MY49100060	2019.10.09	2020.10.08
Temperature & Humidity	HH660	Mieo	N/A	2019.10.12	2020.10.11
Test SW	FARAD	LZ-RF /LzRf-3A3			



3. EMC EMISSION TEST

3.1 CONDUCTED EMISSION MEASUREMENT

3.1.1 POWER LINE CONDUCTED EMISSION Limits (Frequency Range 150KHz-30MHz)

FREQUENCY (MHz)	Class B (dBuV)		Standard
	Quasi-peak	Average	
0.15 -0.5	66 - 56 *	56 - 46 *	CISPR
0.50 -5.0	56.00	46.00	CISPR
5.0 -30.0	60.00	50.00	CISPR

0.15 -0.5	66 - 56 *	56 - 46 *	FCC
0.50 -5.0	56.00	46.00	FCC
5.0 -30.0	60.00	50.00	FCC

Note:

- (1) The tighter limit applies at the band edges.
- (2) The limit of “ * ” marked band means the limitation decreases linearly with the logarithm of the frequency in the range.

The following table is the setting of the receiver

Receiver Parameters	Setting
Attenuation	10 dB
Start Frequency	0.15 MHz
Stop Frequency	30 MHz
IF Bandwidth	9 kHz

3.1.2 TEST PROCEDURE

- a. The EUT was placed 0.8 meters from the horizontal ground plane with EUT being connected to the power mains through a line impedance stabilization network (LISN). All other support equipments powered from additional LISN(s). The LISN provide 50 Ohm/ 50uH of coupling impedance for the measuring instrument.
- b. Interconnecting cables that hang closer than 40 cm to the ground plane shall be folded back and forth in the center forming a bundle 30 to 40 cm long.
- c. I/O cables that are not connected to a peripheral shall be bundled in the center. The end of the cable may be terminated, if required, using the correct terminating impedance. The overall length shall not exceed 1 m.
- d. LISN at least 80 cm from nearest part of EUT chassis.
- e. For the actual test configuration, please refer to the related Item –EUT Test Photos.

3.1.3 DEVIATION FROM TEST STANDARD

No deviation

3.1.4 TEST SETUP

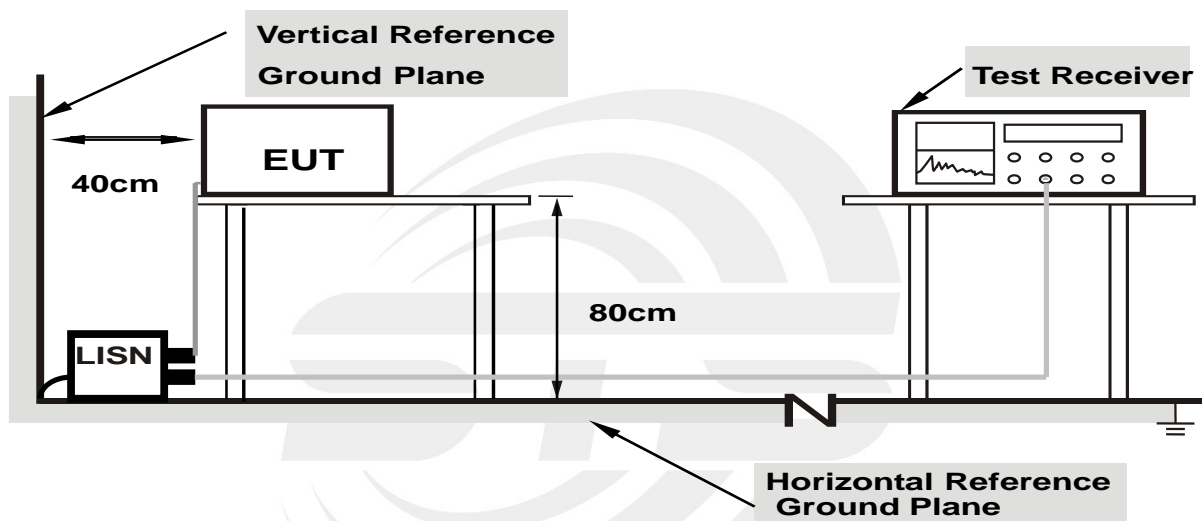

- Note:**
- 1.Support units were connected to second LISN.
 - 2.Both of LISNs (AMN) are 80 cm from EUT and at least 80 from other units and other metal planes

3.1.5 EUT OPERATING CONDITIONS

The EUT was configured for testing in a typical fashion (as a customer would normally use it). The EUT has been programmed to continuously transmit during test. This operating condition was tested and used to collect the included data.



3.1.6 TEST RESULTS

Temperature:	21.4(C)	Relative Humidity:	57%RH
Test Voltage:	AC 120V/60Hz	Phase:	L
Test Mode :	Mode 25		

No.	Frequency (MHz)	Reading (dBUV)	Correct Factor(dB)	Result (dBUV)	Limit (dBUV)	Margin (dB)	Remark
1	0.1820	26.77	20.54	47.31	64.39	-17.08	QP
2	0.1820	18.87	20.54	39.41	54.39	-14.98	AVG
3	0.4220	18.55	20.21	38.76	57.41	-18.65	QP
4	0.4220	11.37	20.21	31.58	47.41	-15.83	AVG
5	1.2780	20.37	19.56	39.93	56.00	-16.07	QP
6	1.2780	4.18	19.56	23.74	46.00	-22.26	AVG
7	3.6100	20.79	20.24	41.03	56.00	-14.97	QP
8	3.6100	3.48	20.24	23.72	46.00	-22.28	AVG
9	6.8180	25.88	20.34	46.22	60.00	-13.78	QP
10	6.8180	6.60	20.34	26.94	50.00	-23.06	AVG
11	13.8780	30.23	20.73	50.96	60.00	-9.04	QP
12	13.8780	11.85	20.73	32.58	50.00	-17.42	AVG

Remark:

1. All readings are Quasi-Peak and Average values.
2. Margin = Result (Result = Reading + Factor) – Limit

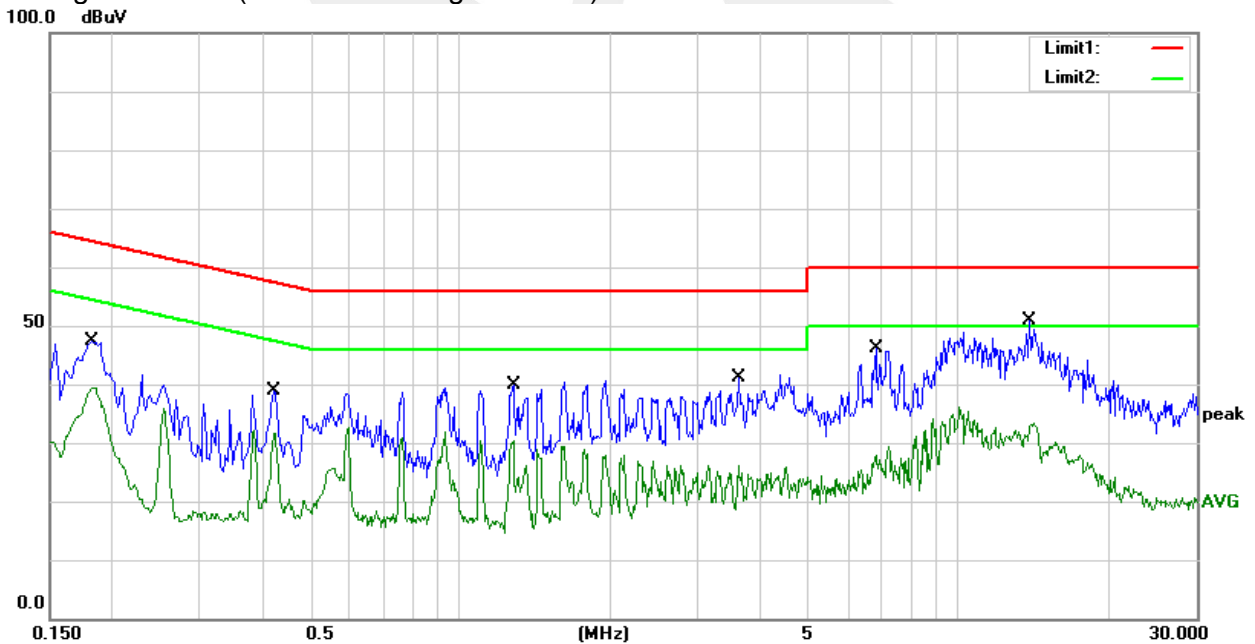



Temperature:	21.4(C)	Relative Humidity:	57%RH
Test Voltage	AC 120V/60Hz	Phase:	N
Test Mode	Mode 25		

No.	Frequency (MHz)	Reading (dBuV)	Correct Factor(dB)	Result (dBuV)	Limit (dBuV)	Margin (dB)	Remark
1	0.1820	25.98	20.54	46.52	64.39	-17.87	QP
2	0.1820	18.55	20.54	39.09	54.39	-15.30	AVG
3	0.5900	18.96	20.07	39.03	56.00	-16.97	QP
4	0.5900	10.08	20.07	30.15	46.00	-15.85	AVG
5	1.7740	20.77	19.82	40.59	56.00	-15.41	QP
6	1.7740	7.73	19.82	27.55	46.00	-18.45	AVG
7	4.0820	19.87	20.30	40.17	56.00	-15.83	QP
8	4.0820	3.96	20.30	24.26	46.00	-21.74	AVG
9	9.5980	29.89	20.53	50.42	60.00	-9.58	QP
10	9.5980	12.78	20.53	33.31	50.00	-16.69	AVG
11	15.1340	28.60	20.70	49.30	60.00	-10.70	QP
12	15.1340	10.44	20.70	31.14	50.00	-18.86	AVG

Remark:

1. All readings are Quasi-Peak and Average values.
2. Margin = Result (Result = Reading + Factor) - Limit

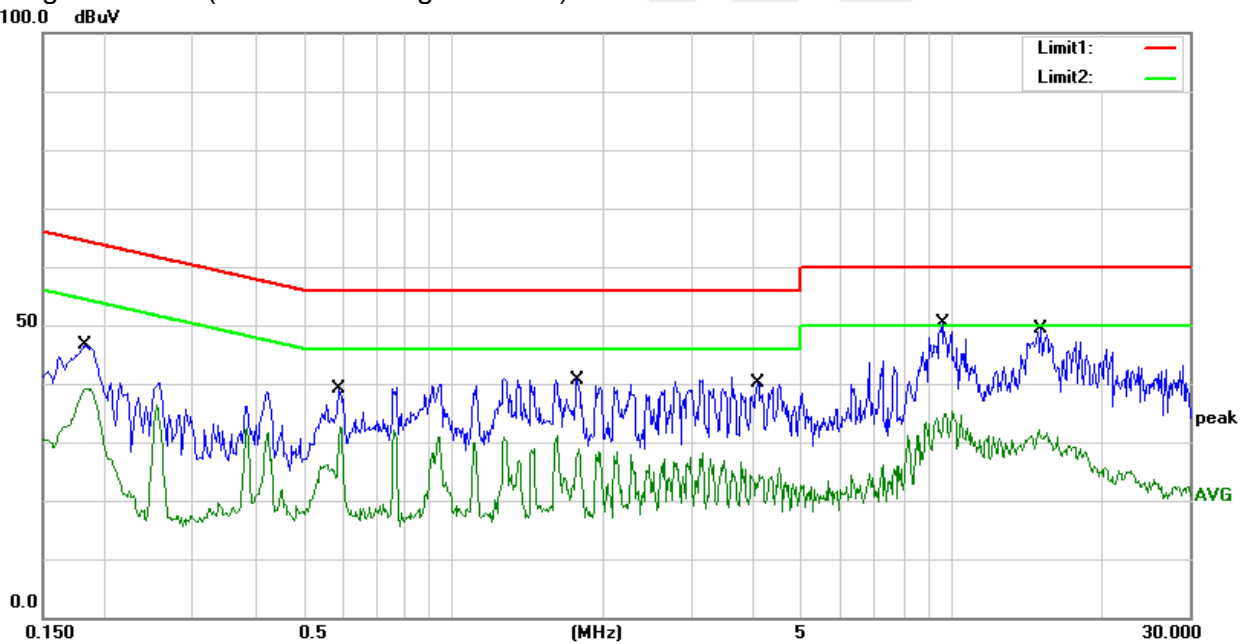

3.2 RADIATED EMISSION AND (BANDEDGE) MEASUREMENT

3.2.1 RADIATED EMISSION LIMITS (Frequency Range 9kHz-1000MHz)

In case the emission fall within the restricted band specified on 15.407(b)7& 15.205/209(a), then the (a); limit in the table below has to be followed.

Frequencies (MHz)	Field Strength (micorvolts/meter)	Measurement Distance (meters)
0.009~0.490	2400/F(KHz)	300
0.490~1.705	24000/F(KHz)	30
1.705~30.0	30	30
30~88	100	3
88~216	150	3
216~960	200	3
Above 960	500	3

LIMITS OF RADIATED EMISSION MEASUREMENT (Above 1000MHz)

FREQUENCY (MHz)	Class B (dBuV/m) (at 3M)	
	PEAK	AVERAGE
Above 1000	68.2	54

Notes:

- (1) The limit for radiated test was performed according to FCC PART 15E.
- (2) The tighter limit applies at the band edges.
- (3) Emission level (dBuV/m)=20log Emission level (uV/m).

Spectrum Parameter	Setting
Attenuation	Auto
Detector	Peak
Start Frequency	1000 MHz(Peak/AV)
Stop Frequency	10th carrier harmonic(Peak/AV)
RB / VB (emission in restricted band)	1 MHz / 1 MHz, AV=1 MHz /3 MHz

For Band edge

Spectrum Parameter	Setting
Detector	Peak
RB / VB (emission in restricted band)	1 MHz / 1 MHz, AV=1 MHz /3 MHz



Receiver Parameter	Setting
Attenuation	Auto
Start ~ Stop Frequency	9kHz~90kHz / RB 200Hz for PK & AV
Start ~ Stop Frequency	90kHz~110kHz / RB 200Hz for QP
Start ~ Stop Frequency	110kHz~490kHz / RB 200Hz for PK & AV
Start ~ Stop Frequency	490kHz~30MHz / RB 9kHz for QP
Start ~ Stop Frequency	30MHz~1000MHz / RB 120kHz for QP

3.2.2 TEST PROCEDURE

- The measuring distance of at 3 m shall be used for measurements at frequency 0.009MHz up to 1GHz. For frequencies above 1GHz, any suitable measuring distance may be used.
- The EUT was placed on the top of a rotating table 0.8 meters(above 1GHz is 1.5 m) above the ground at a 3 meter anechoic chamber. The table was rotated 360 degrees to determine the position of the highest radiation.
- The height of the equipment shall be 0.8 m(above 1GHz is 1.5 m); the height of the test antenna shall vary between 1 m to 4 m. Horizontal and vertical polarizations of the antenna are set to make the measurement
- The initial step in collecting conducted emission data is a spectrum analyzer peak detector mode pre-scanning the measurement frequency range. Significant peaks are then marked and then Quasi Peak detector mode re-measured.
- If the Peak Mode measured value compliance with and lower than Quasi Peak Mode Limit, the EUT shall be deemed to meet QP Limits and then no additional QP Mode measurement performed.
- For the actual test configuration, please refer to the related Item –EUT Test Photos.

Note:

Both horizontal and vertical antenna polarities were tested and performed test to three orthogonal axis. The worst case emissions were reported

3.2.2 DEVIATION FROM TEST STANDARD

No deviation

(A) Radiated Emission Test-Up Frequency Below 30MHz

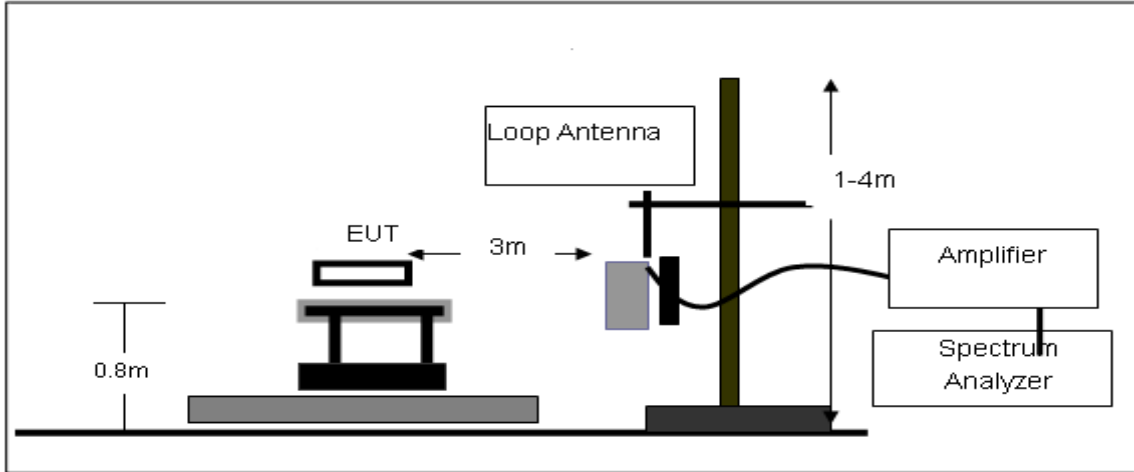

(B) Radiated Emission Test-Up Frequency 30MHz~1GHz

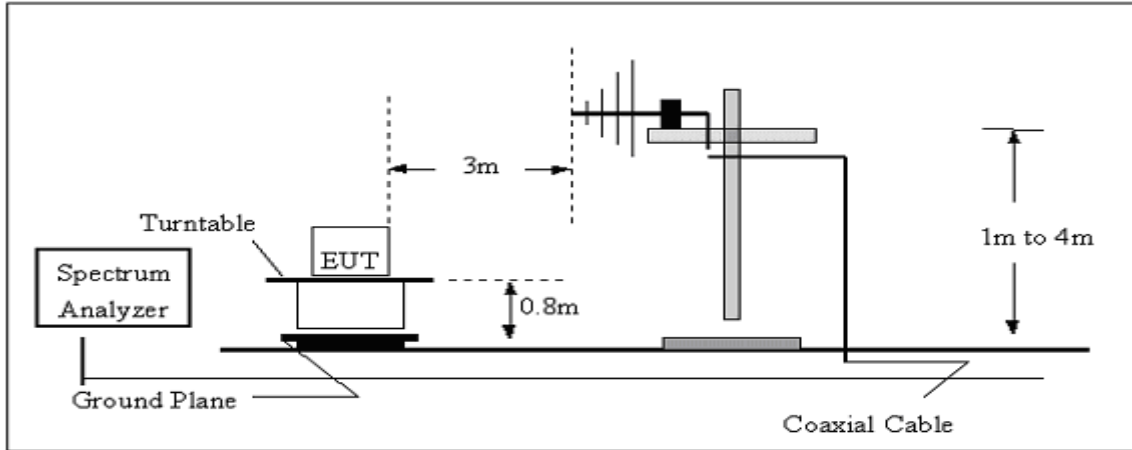

(C) Radiated Emission Test-Up Frequency Above 1GHz

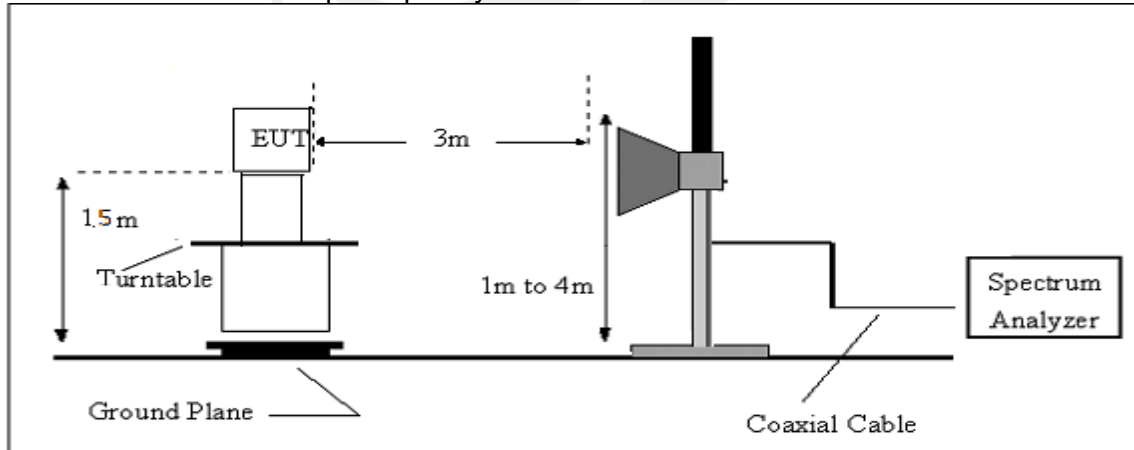



3.2.4 EUT OPERATING CONDITIONS

The EUT tested system was configured as the statements of 2.4 Unless otherwise a special operating condition is specified in the follows during the testing.

3.2.5 FIELD STRENGTH CALCULATION

The field strength is calculated by adding the Antenna Factor and Cable Factor and subtracting the Amplifier Gain and Duty Cycle Correction Factor (if any) from the measured reading. The basic equation with a sample calculation is as follows:

$$FS = RA + AF + CL - AG$$

Where

FS = Field Strength

CL = Cable Attenuation Factor (Cable Loss)

RA = Reading Amplitude

AG = Amplifier Gain

AF = Antenna Factor

For example

Frequency (MHz)	FS (dBμV/m)	RA (dBμV/m)	AF (dB)	CL (dB)	AG (dB)	Factor (dB)
300	40	58.1	12.2	1.6	31.9	-18.1

$$\text{Factor} = \text{AF} + \text{CL} - \text{AG}$$



**3.2.6 TEST RESULTS (Between 9KHz – 30 MHz)**

Temperature:	23.6(C)	Relative Humidity:	62%RH
Test Voltage:	AC 120V/60Hz	Polarization :	--
Test Mode:	TX Mode		

Freq.	Reading	Limit	Margin	State
(MHz)	(dBuV/m)	(dBuV/m)	(dB)	P/F
--	--	--	--	PASS
--	--	--	--	PASS

Note:

The amplitude of spurious emissions which are attenuated by more than 20dB below the permissible value has no need to be reported.

Distance extrapolation factor = $40 \log(\text{specific distance}/\text{test distance})$ (dB);

Limit line = specific limits(dBuV) + distance extrapolation factor.

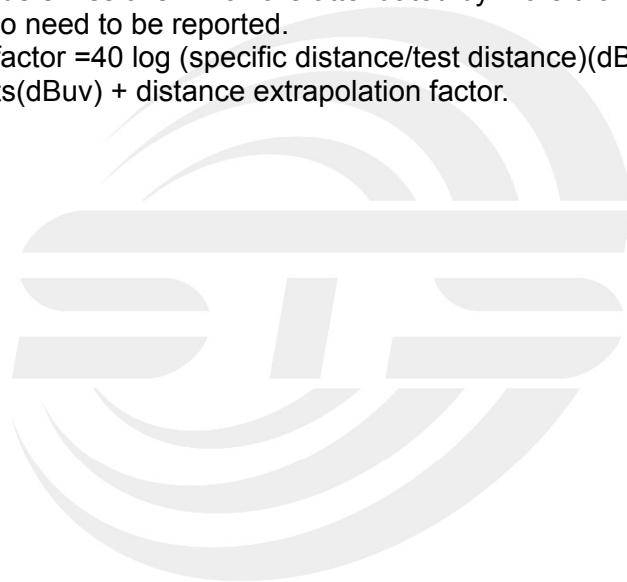



3.2.7 TEST RESULTS (Between 30MHz – 1GHz)

Temperature	23.6(C)	Relative Humidity:	62%RH
Test Voltage	AC 230V/50Hz	Polarization:	Horizontal
Test Mode	Mode 1~24(Mode 18 worst mode)		

No.	Frequency (MHz)	Reading (dBuV)	Correct Factor(dB/m)	Result (dBuV/m)	Limit (dBuV/m)	Margin (dB)	Remark
1	47.4600	59.67	-21.92	37.75	40.00	-2.25	QP
2	108.5700	57.91	-19.22	38.69	43.50	-4.81	QP
3	250.1900	54.50	-16.10	38.40	46.00	-7.60	QP
4	543.1300	46.22	-6.52	39.70	46.00	-6.30	QP
5	696.3900	45.73	-4.23	41.50	46.00	-4.50	QP
6	911.7300	38.06	-0.16	37.90	46.00	-8.10	QP

Remark:

1. Margin = Result (Result = Reading + Factor) – Limit

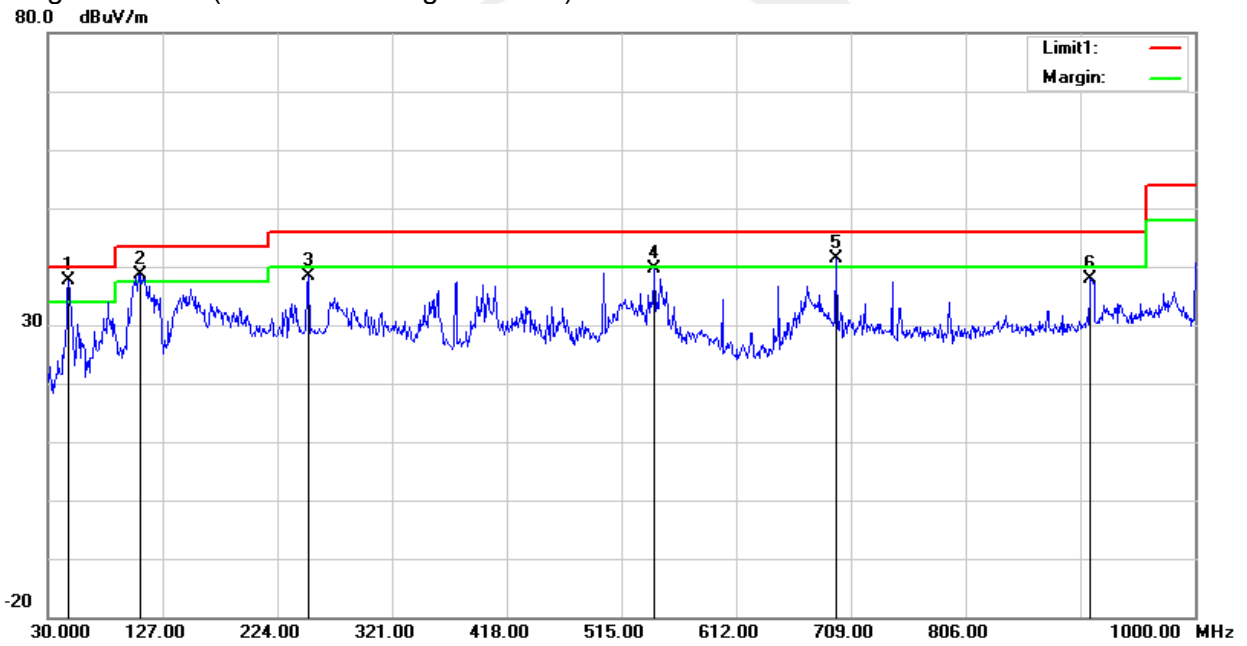



Temperature	23.6(C)	Relative Humidity:	62%RH
Test Voltage	AC 120V/60Hz	Polarization:	Vertical
Test Mode	Mode 1~24(Mode 18 worst mode)		

No.	Frequency (MHz)	Reading (dBuV)	Correct Factor(dB/m)	Result (dBuV/m)	Limit (dBuV/m)	Margin (dB)	Remark
1	47.4600	58.54	-21.92	36.62	40.00	-3.38	QP
2	250.1900	55.38	-16.10	39.28	46.00	-6.72	QP
3	359.8000	49.93	-12.87	37.06	46.00	-8.94	QP
4	500.4500	43.52	-8.01	35.51	46.00	-10.49	QP
5	792.4200	40.60	-1.99	38.61	46.00	-7.39	QP
6	912.7000	39.50	-0.14	39.36	46.00	-6.64	QP

Remark:

1. Margin = Result (Result =Reading + Factor)-Limit

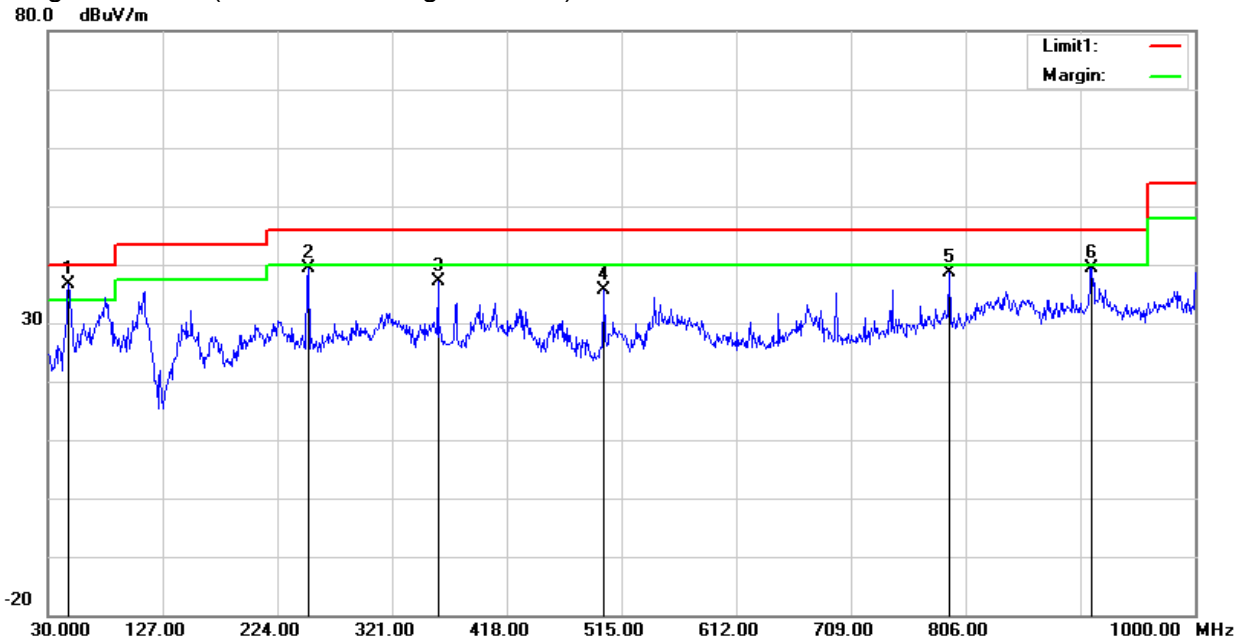



3.2.8 TEST RESULTS (Above 1000 MHz)

Band I 5150-5250MHz

Frequency (MHz)	Reading (dBuV)	Amplifier (dB)	Loss (dB)	Antenna Factor (dB/m)	Orrected Factor (dB)	Emission Level (dBuV/m)	Limit (dBuV/m)	Margin (dB)	Detector	Comment
Low Channel (802.11/ 5180 MHz)										
3251.75	43.89	44.70	6.70	28.20	-9.80	34.09	68.20	-34.11	Pk	Vertical
3251.75	42.17	44.70	6.70	28.20	-9.80	32.37	54.00	-21.63	AV	Vertical
3246.99	44.89	44.70	6.70	28.20	-9.80	35.09	68.20	-33.11	Pk	Horizontal
3246.99	41.82	44.70	6.70	28.20	-9.80	32.02	54.00	-21.98	AV	Horizontal
3996.06	39.68	44.20	7.90	29.70	-6.60	33.08	68.20	-35.12	Pk	Vertical
3996.06	36.15	44.20	7.90	29.70	-6.60	29.55	54.00	-24.45	AV	Vertical
3990.13	40.14	44.20	7.90	29.70	-6.60	33.54	68.20	-34.66	Pk	Horizontal
3990.13	36.93	44.20	7.90	29.70	-6.60	30.33	54.00	-23.67	AV	Horizontal
7222.29	36.84	43.50	11.40	35.50	3.40	40.24	68.20	-27.96	Pk	Vertical
7222.29	33.92	43.50	11.40	35.50	3.40	37.32	54.00	-16.68	AV	Vertical
7217.54	37.93	43.50	11.40	35.50	3.40	41.33	68.20	-26.87	Pk	Horizontal
7217.54	34.44	43.50	11.40	35.50	3.40	37.84	54.00	-16.16	AV	Horizontal
10360.27	39.07	44.50	13.80	38.80	8.10	47.17	68.20	-21.03	Pk	Vertical
10360.27	35.70	44.50	13.80	38.80	8.10	43.80	54.00	-10.20	AV	Vertical
10360.35	39.12	44.50	13.80	38.80	8.10	47.22	68.20	-20.98	Pk	Horizontal
10360.35	36.47	44.50	13.80	38.80	8.10	44.57	54.00	-9.43	AV	Horizontal
11023.69	34.04	43.60	14.30	39.50	10.20	44.24	68.20	-23.96	Pk	Vertical
11023.69	30.65	43.60	14.30	39.50	10.20	40.85	54.00	-13.15	AV	Vertical
11025.30	33.89	43.60	14.30	39.50	10.20	44.09	68.20	-24.11	Pk	Horizontal
11025.30	30.63	43.60	14.30	39.50	10.20	40.83	54.00	-13.17	AV	Horizontal
13299.82	31.78	42.60	15.90	38.90	12.20	43.98	68.20	-24.22	Pk	Vertical
13299.82	28.62	42.60	15.90	38.90	12.20	40.82	54.00	-13.18	AV	Vertical
13282.09	33.01	42.60	15.90	38.90	12.20	45.21	68.20	-22.99	Pk	Horizontal
13282.09	28.64	42.60	15.90	38.90	12.20	40.84	54.00	-13.16	AV	Horizontal
Mid Channel (802.11/ 5200 MHz)										
3250.51	44.54	44.70	6.70	28.20	-9.80	34.74	68.20	-33.46	Pk	Vertical
3250.51	41.16	44.70	6.70	28.20	-9.80	31.36	54.00	-22.64	AV	Vertical
3252.99	44.69	44.70	6.70	28.20	-9.80	34.89	68.20	-33.31	Pk	Horizontal
3252.99	42.04	44.70	6.70	28.20	-9.80	32.24	54.00	-21.76	AV	Horizontal
3997.36	38.91	44.20	7.90	29.70	-6.60	32.31	68.20	-35.89	Pk	Vertical
3997.36	36.41	44.20	7.90	29.70	-6.60	29.81	54.00	-24.19	AV	Vertical
3983.97	39.48	44.20	7.90	29.70	-6.60	32.88	68.20	-35.32	Pk	Horizontal
3983.97	36.21	44.20	7.90	29.70	-6.60	29.61	54.00	-24.39	AV	Horizontal
7219.11	37.03	43.50	11.40	35.50	3.40	40.43	68.20	-27.77	Pk	Vertical
7219.11	33.55	43.50	11.40	35.50	3.40	36.95	54.00	-17.05	AV	Vertical
7222.77	37.08	43.50	11.40	35.50	3.40	40.48	68.20	-27.72	Pk	Horizontal
7222.77	33.60	43.50	11.40	35.50	3.40	37.00	54.00	-17.00	AV	Horizontal
10400.33	39.10	44.50	13.80	38.80	8.10	47.20	68.20	-21.00	Pk	Vertical
10400.33	35.92	44.50	13.80	38.80	8.10	44.02	54.00	-9.98	AV	Vertical
10400.24	39.30	44.50	13.80	38.80	8.10	47.40	68.20	-20.80	Pk	Horizontal
10400.24	37.13	44.50	13.80	38.80	8.10	45.23	54.00	-8.77	AV	Horizontal
11030.20	33.37	43.60	14.30	39.50	10.20	43.57	68.20	-24.63	Pk	Vertical
11030.20	29.72	43.60	14.30	39.50	10.20	39.92	54.00	-14.08	AV	Vertical
11029.77	33.35	43.60	14.30	39.50	10.20	43.55	68.20	-24.65	Pk	Horizontal
11029.77	29.96	43.60	14.30	39.50	10.20	40.16	54.00	-13.84	AV	Horizontal
13292.65	32.19	42.60	15.90	38.90	12.20	44.39	68.20	-23.81	Pk	Vertical
13292.65	28.77	42.60	15.90	38.90	12.20	40.97	54.00	-13.03	AV	Vertical
13291.59	31.60	42.60	15.90	38.90	12.20	43.80	68.20	-24.40	Pk	Horizontal
13291.59	29.05	42.60	15.90	38.90	12.20	41.25	54.00	-12.75	AV	Horizontal



High Channel (802.11/ 5240 MHz)										
3247.75	45.17	44.70	6.70	28.20	-9.80	35.37	68.20	-32.83	Pk	Vertical
3247.75	41.23	44.70	6.70	28.20	-9.80	31.43	54.00	-22.57	AV	Vertical
3246.82	44.77	44.70	6.70	28.20	-9.80	34.97	68.20	-33.23	Pk	Horizontal
3246.82	42.19	44.70	6.70	28.20	-9.80	32.39	54.00	-21.61	AV	Horizontal
4000.12	38.66	44.20	7.90	29.70	-6.60	32.06	68.20	-36.14	Pk	Vertical
4000.12	36.01	44.20	7.90	29.70	-6.60	29.41	54.00	-24.59	AV	Vertical
3980.53	39.75	44.20	7.90	29.70	-6.60	33.15	68.20	-35.05	Pk	Horizontal
3980.53	36.87	44.20	7.90	29.70	-6.60	30.27	54.00	-23.73	AV	Horizontal
7217.00	36.82	43.50	11.40	35.50	3.40	40.22	68.20	-27.98	Pk	Vertical
7217.00	34.84	43.50	11.40	35.50	3.40	38.24	54.00	-15.76	AV	Vertical
7228.52	36.92	43.50	11.40	35.50	3.40	40.32	68.20	-27.88	Pk	Horizontal
7228.52	33.62	43.50	11.40	35.50	3.40	37.02	54.00	-16.98	AV	Horizontal
10480.30	39.46	44.50	13.80	38.80	8.10	47.56	68.20	-20.64	Pk	Vertical
10480.30	36.42	44.50	13.80	38.80	8.10	44.52	54.00	-9.48	AV	Vertical
10480.21	39.18	44.50	13.80	38.80	8.10	47.28	68.20	-20.92	Pk	Horizontal
10480.21	36.63	44.50	13.80	38.80	8.10	44.73	54.00	-9.27	AV	Horizontal
11035.71	33.95	43.60	14.30	39.50	10.20	44.15	68.20	-24.05	Pk	Vertical
11035.71	30.38	43.60	14.30	39.50	10.20	40.58	54.00	-13.42	AV	Vertical
11023.61	33.41	43.60	14.30	39.50	10.20	43.61	68.20	-24.59	Pk	Horizontal
11023.61	30.48	43.60	14.30	39.50	10.20	40.68	54.00	-13.32	AV	Horizontal
13285.05	32.07	42.60	15.90	38.90	12.20	44.27	68.20	-23.93	Pk	Vertical
13285.05	29.80	42.60	15.90	38.90	12.20	42.00	54.00	-12.00	AV	Vertical
13292.46	31.77	42.60	15.90	38.90	12.20	43.97	68.20	-24.23	Pk	Horizontal
13292.46	29.83	42.60	15.90	38.90	12.20	42.03	54.00	-11.97	AV	Horizontal

Remark:

- Factor = Antenna Factor + Cable Loss – Pre-amplifier.
- Scan with 802.11a,802.11n (HT-20),802.11n (HT-40), 802.11ac (VHT-20),802.11ac (VHT-40), 802.11ac (VHT-80) the worst case is 802.11n (HT-20).
- The frequency emission of peak points that did not show above the forms are at least 20dB below the limit, the frequency emission is mainly from the environment noise.



Band II 5250-5350MHz

Frequency (MHz)	Reading (dBuV)	Amplifier (dB)	Loss (dB)	Antenna Factor (dB/m)	Orrected Factor (dB)	Emission Level (dBuV/m)	Limit (dBuV/m)	Margin (dB)	Detector	Comment
Low Channel (802.11/ 5260 MHz)										
3254.56	43.97	44.70	6.70	28.20	-9.80	34.17	68.20	-34.03	Pk	Vertical
3254.56	40.84	44.70	6.70	28.20	-9.80	31.04	54.00	-22.96	AV	Vertical
3248.12	44.21	44.70	6.70	28.20	-9.80	34.41	68.20	-33.79	Pk	Horizontal
3248.12	41.04	44.70	6.70	28.20	-9.80	31.24	54.00	-22.76	AV	Horizontal
3994.22	39.52	44.20	7.90	29.70	-6.60	32.92	68.20	-35.28	Pk	Vertical
3994.22	36.01	44.20	7.90	29.70	-6.60	29.41	54.00	-24.59	AV	Vertical
3988.88	39.62	44.20	7.90	29.70	-6.60	33.02	68.20	-35.18	Pk	Horizontal
3988.88	36.08	44.20	7.90	29.70	-6.60	29.48	54.00	-24.52	AV	Horizontal
7221.91	37.83	43.50	11.40	35.50	3.40	41.23	68.20	-26.97	Pk	Vertical
7221.91	33.59	43.50	11.40	35.50	3.40	36.99	54.00	-17.01	AV	Vertical
7228.94	36.50	43.50	11.40	35.50	3.40	39.90	68.20	-28.30	Pk	Horizontal
7228.94	34.47	43.50	11.40	35.50	3.40	37.87	54.00	-16.13	AV	Horizontal
10360.13	39.04	44.50	13.80	38.80	8.10	47.14	68.20	-21.06	Pk	Vertical
10360.13	36.67	44.50	13.80	38.80	8.10	44.77	54.00	-9.23	AV	Vertical
10360.32	39.00	44.50	13.80	38.80	8.10	47.10	68.20	-21.10	Pk	Horizontal
10360.32	35.86	44.50	13.80	38.80	8.10	43.96	54.00	-10.04	AV	Horizontal
11023.09	33.48	43.60	14.30	39.50	10.20	43.68	68.20	-24.52	Pk	Vertical
11023.09	30.22	43.60	14.30	39.50	10.20	40.42	54.00	-13.58	AV	Vertical
11036.35	32.93	43.60	14.30	39.50	10.20	43.13	68.20	-25.07	Pk	Horizontal
11036.35	31.16	43.60	14.30	39.50	10.20	41.36	54.00	-12.64	AV	Horizontal
13298.60	32.27	42.60	15.90	38.90	12.20	44.47	68.20	-23.73	Pk	Vertical
13298.60	28.55	42.60	15.90	38.90	12.20	40.75	54.00	-13.25	AV	Vertical
13293.78	31.71	42.60	15.90	38.90	12.20	43.91	68.20	-24.29	Pk	Horizontal
13293.78	29.22	42.60	15.90	38.90	12.20	41.42	54.00	-12.58	AV	Horizontal
Mid Channel (802.11/ 5300 MHz)										
3250.07	43.85	44.70	6.70	28.20	-9.80	34.05	68.20	-34.15	Pk	Vertical
3250.07	42.08	44.70	6.70	28.20	-9.80	32.28	54.00	-21.72	AV	Vertical
3254.80	44.54	44.70	6.70	28.20	-9.80	34.74	68.20	-33.46	Pk	Horizontal
3254.80	41.01	44.70	6.70	28.20	-9.80	31.21	54.00	-22.79	AV	Horizontal
3991.78	39.32	44.20	7.90	29.70	-6.60	32.72	68.20	-35.48	Pk	Vertical
3991.78	36.79	44.20	7.90	29.70	-6.60	30.19	54.00	-23.81	AV	Vertical
3982.64	39.06	44.20	7.90	29.70	-6.60	32.46	68.20	-35.74	Pk	Horizontal
3982.64	36.93	44.20	7.90	29.70	-6.60	30.33	54.00	-23.67	AV	Horizontal
7221.02	37.88	43.50	11.40	35.50	3.40	41.28	68.20	-26.92	Pk	Vertical
7221.02	34.68	43.50	11.40	35.50	3.40	38.08	54.00	-15.92	AV	Vertical
7229.43	37.35	43.50	11.40	35.50	3.40	40.75	68.20	-27.45	Pk	Horizontal
7229.43	34.03	43.50	11.40	35.50	3.40	37.43	54.00	-16.57	AV	Horizontal
10400.31	38.79	44.50	13.80	38.80	8.10	46.89	68.20	-21.31	Pk	Vertical
10400.31	36.31	44.50	13.80	38.80	8.10	44.41	54.00	-9.59	AV	Vertical
10400.32	39.52	44.50	13.80	38.80	8.10	47.62	68.20	-20.58	Pk	Horizontal
10400.32	36.20	44.50	13.80	38.80	8.10	44.30	54.00	-9.70	AV	Horizontal
11028.64	33.93	43.60	14.30	39.50	10.20	44.13	68.20	-24.07	Pk	Vertical
11028.64	30.85	43.60	14.30	39.50	10.20	41.05	54.00	-12.95	AV	Vertical
11031.29	33.97	43.60	14.30	39.50	10.20	44.17	68.20	-24.03	Pk	Horizontal
11031.29	30.88	43.60	14.30	39.50	10.20	41.08	54.00	-12.92	AV	Horizontal
13285.92	31.53	42.60	15.90	38.90	12.20	43.73	68.20	-24.47	Pk	Vertical
13285.92	29.32	42.60	15.90	38.90	12.20	41.52	54.00	-12.48	AV	Vertical
13297.52	32.90	42.60	15.90	38.90	12.20	45.10	68.20	-23.10	Pk	Horizontal
13297.52	29.95	42.60	15.90	38.90	12.20	42.15	54.00	-11.85	AV	Horizontal



High Channel (802.11/ 5320 MHz)										
3260.35	44.82	44.70	6.70	28.20	-9.80	35.02	68.20	-33.18	Pk	Vertical
3260.35	41.23	44.70	6.70	28.20	-9.80	31.43	54.00	-22.57	AV	Vertical
3253.95	44.37	44.70	6.70	28.20	-9.80	34.57	68.20	-33.63	Pk	Horizontal
3253.95	40.75	44.70	6.70	28.20	-9.80	30.95	54.00	-23.05	AV	Horizontal
3999.46	39.58	44.20	7.90	29.70	-6.60	32.98	68.20	-35.22	Pk	Vertical
3999.46	36.80	44.20	7.90	29.70	-6.60	30.20	54.00	-23.80	AV	Vertical
3999.12	38.94	44.20	7.90	29.70	-6.60	32.34	68.20	-35.86	Pk	Horizontal
3999.12	37.01	44.20	7.90	29.70	-6.60	30.41	54.00	-23.59	AV	Horizontal
7222.48	36.86	43.50	11.40	35.50	3.40	40.26	68.20	-27.94	Pk	Vertical
7222.48	34.18	43.50	11.40	35.50	3.40	37.58	54.00	-16.42	AV	Vertical
7218.63	37.05	43.50	11.40	35.50	3.40	40.45	68.20	-27.75	Pk	Horizontal
7218.63	34.43	43.50	11.40	35.50	3.40	37.83	54.00	-16.17	AV	Horizontal
10480.20	39.95	44.50	13.80	38.80	8.10	48.05	68.20	-20.15	Pk	Vertical
10480.20	36.42	44.50	13.80	38.80	8.10	44.52	54.00	-9.48	AV	Vertical
10480.22	39.36	44.50	13.80	38.80	8.10	47.46	68.20	-20.74	Pk	Horizontal
10480.22	35.81	44.50	13.80	38.80	8.10	43.91	54.00	-10.09	AV	Horizontal
11031.09	33.49	43.60	14.30	39.50	10.20	43.69	68.20	-24.51	Pk	Vertical
11031.09	30.52	43.60	14.30	39.50	10.20	40.72	54.00	-13.28	AV	Vertical
11028.15	33.25	43.60	14.30	39.50	10.20	43.45	68.20	-24.75	Pk	Horizontal
11028.15	30.37	43.60	14.30	39.50	10.20	40.57	54.00	-13.43	AV	Horizontal
13290.37	32.79	42.60	15.90	38.90	12.20	44.99	68.20	-23.21	Pk	Vertical
13290.37	28.97	42.60	15.90	38.90	12.20	41.17	54.00	-12.83	AV	Vertical
13282.76	32.55	42.60	15.90	38.90	12.20	44.75	68.20	-23.45	Pk	Horizontal
13282.76	29.36	42.60	15.90	38.90	12.20	41.56	54.00	-12.44	AV	Horizontal

Remark:

1. Factor = Antenna Factor + Cable Loss – Pre-amplifier.
2. Scan with 802.11a,802.11n (HT-20),802.11n (HT-40), 802.11ac (VHT-20),802.11ac (VHT-40), 802.11ac (VHT-80) the worst case is 802.11n (HT-20).
3. The frequency emission of peak points that did not show above the forms are at least 20dB below the limit, the frequency emission is mainly from the environment noise.



Band III 5470-5725MHz

Frequency (MHz)	Reading (dBuV)	Amplifier (dB)	Loss (dB)	Antenna Factor (dB/m)	Orrected Factor (dB)	Emission Level (dBuV/m)	Limit (dBuV/m)	Margin (dB)	Detector	Comment
Low Channel (802.11/ 5500 MHz)										
3246.63	44.76	44.70	6.70	28.20	-9.80	34.96	68.20	-33.24	Pk	Vertical
3246.63	41.46	44.70	6.70	28.20	-9.80	31.66	54.00	-22.34	AV	Vertical
3258.86	45.13	44.70	6.70	28.20	-9.80	35.33	68.20	-32.87	Pk	Horizontal
3258.86	40.99	44.70	6.70	28.20	-9.80	31.19	54.00	-22.81	AV	Horizontal
3988.11	39.31	44.20	7.90	29.70	-6.60	32.71	68.20	-35.49	Pk	Vertical
3988.11	36.70	44.20	7.90	29.70	-6.60	30.10	54.00	-23.90	AV	Vertical
3982.72	38.71	44.20	7.90	29.70	-6.60	32.11	68.20	-36.09	Pk	Horizontal
3982.72	37.08	44.20	7.90	29.70	-6.60	30.48	54.00	-23.52	AV	Horizontal
7227.75	36.89	43.50	11.40	35.50	3.40	40.29	68.20	-27.91	Pk	Vertical
7227.75	34.01	43.50	11.40	35.50	3.40	37.41	54.00	-16.59	AV	Vertical
7223.52	37.30	43.50	11.40	35.50	3.40	40.70	68.20	-27.50	Pk	Horizontal
7223.52	34.35	43.50	11.40	35.50	3.40	37.75	54.00	-16.25	AV	Horizontal
10360.16	39.49	44.50	13.80	38.80	8.10	47.59	68.20	-20.61	Pk	Vertical
10360.16	36.89	44.50	13.80	38.80	8.10	44.99	54.00	-9.01	AV	Vertical
10360.09	40.03	44.50	13.80	38.80	8.10	48.13	68.20	-20.07	Pk	Horizontal
10360.09	36.92	44.50	13.80	38.80	8.10	45.02	54.00	-8.98	AV	Horizontal
11020.08	33.15	43.60	14.30	39.50	10.20	43.35	68.20	-24.85	Pk	Vertical
11020.08	30.57	43.60	14.30	39.50	10.20	40.77	54.00	-13.23	AV	Vertical
11028.09	33.73	43.60	14.30	39.50	10.20	43.93	68.20	-24.27	Pk	Horizontal
11028.09	30.88	43.60	14.30	39.50	10.20	41.08	54.00	-12.92	AV	Horizontal
13294.48	32.58	42.60	15.90	38.90	12.20	44.78	68.20	-23.42	Pk	Vertical
13294.48	28.86	42.60	15.90	38.90	12.20	41.06	54.00	-12.94	AV	Vertical
13280.40	32.95	42.60	15.90	38.90	12.20	45.15	68.20	-23.05	Pk	Horizontal
13280.40	28.60	42.60	15.90	38.90	12.20	40.80	54.00	-13.20	AV	Horizontal
Mid Channel (802.11/ 5580 MHz)										
3260.53	43.85	44.70	6.70	28.20	-9.80	34.05	68.20	-34.15	Pk	Vertical
3260.53	41.04	44.70	6.70	28.20	-9.80	31.24	54.00	-22.76	AV	Vertical
3255.08	44.78	44.70	6.70	28.20	-9.80	34.98	68.20	-33.22	Pk	Horizontal
3255.08	41.27	44.70	6.70	28.20	-9.80	31.47	54.00	-22.53	AV	Horizontal
3992.77	39.28	44.20	7.90	29.70	-6.60	32.68	68.20	-35.52	Pk	Vertical
3992.77	36.43	44.20	7.90	29.70	-6.60	29.83	54.00	-24.17	AV	Vertical
3996.04	39.45	44.20	7.90	29.70	-6.60	32.85	68.20	-35.35	Pk	Horizontal
3996.04	36.42	44.20	7.90	29.70	-6.60	29.82	54.00	-24.18	AV	Horizontal
7216.60	37.57	43.50	11.40	35.50	3.40	40.97	68.20	-27.23	Pk	Vertical
7216.60	34.41	43.50	11.40	35.50	3.40	37.81	54.00	-16.19	AV	Vertical
7229.09	36.88	43.50	11.40	35.50	3.40	40.28	68.20	-27.92	Pk	Horizontal
7229.09	34.28	43.50	11.40	35.50	3.40	37.68	54.00	-16.32	AV	Horizontal
10400.21	39.62	44.50	13.80	38.80	8.10	47.72	68.20	-20.48	Pk	Vertical
10400.21	36.02	44.50	13.80	38.80	8.10	44.12	54.00	-9.88	AV	Vertical
10400.41	38.90	44.50	13.80	38.80	8.10	47.00	68.20	-21.20	Pk	Horizontal
10400.41	36.31	44.50	13.80	38.80	8.10	44.41	54.00	-9.59	AV	Horizontal
11017.18	33.26	43.60	14.30	39.50	10.20	43.46	68.20	-24.74	Pk	Vertical
11017.18	30.21	43.60	14.30	39.50	10.20	40.41	54.00	-13.59	AV	Vertical
11034.38	34.11	43.60	14.30	39.50	10.20	44.31	68.20	-23.89	Pk	Horizontal
11034.38	29.69	43.60	14.30	39.50	10.20	39.89	54.00	-14.11	AV	Horizontal
13288.39	31.85	42.60	15.90	38.90	12.20	44.05	68.20	-24.15	Pk	Vertical
13288.39	29.69	42.60	15.90	38.90	12.20	41.89	54.00	-12.11	AV	Vertical
13284.93	32.51	42.60	15.90	38.90	12.20	44.71	68.20	-23.49	Pk	Horizontal
13284.93	29.91	42.60	15.90	38.90	12.20	42.11	54.00	-11.89	AV	Horizontal



High Channel (802.11/ 5700 MHz)										
3261.61	45.25	44.70	6.70	28.20	-9.80	35.45	68.20	-32.75	Pk	Vertical
3261.61	41.70	44.70	6.70	28.20	-9.80	31.90	54.00	-22.10	AV	Vertical
3259.11	44.24	44.70	6.70	28.20	-9.80	34.44	68.20	-33.76	Pk	Horizontal
3259.11	40.78	44.70	6.70	28.20	-9.80	30.98	54.00	-23.02	AV	Horizontal
3987.32	40.03	44.20	7.90	29.70	-6.60	33.43	68.20	-34.77	Pk	Vertical
3987.32	36.08	44.20	7.90	29.70	-6.60	29.48	54.00	-24.52	AV	Vertical
3981.28	39.71	44.20	7.90	29.70	-6.60	33.11	68.20	-35.09	Pk	Horizontal
3981.28	37.03	44.20	7.90	29.70	-6.60	30.43	54.00	-23.57	AV	Horizontal
7227.94	36.63	43.50	11.40	35.50	3.40	40.03	68.20	-28.17	Pk	Vertical
7227.94	34.86	43.50	11.40	35.50	3.40	38.26	54.00	-15.74	AV	Vertical
7217.73	37.72	43.50	11.40	35.50	3.40	41.12	68.20	-27.08	Pk	Horizontal
7217.73	34.80	43.50	11.40	35.50	3.40	38.20	54.00	-15.80	AV	Horizontal
10480.31	39.96	44.50	13.80	38.80	8.10	48.06	68.20	-20.14	Pk	Vertical
10480.31	36.33	44.50	13.80	38.80	8.10	44.43	54.00	-9.57	AV	Vertical
10480.36	39.42	44.50	13.80	38.80	8.10	47.52	68.20	-20.68	Pk	Horizontal
10480.36	37.15	44.50	13.80	38.80	8.10	45.25	54.00	-8.75	AV	Horizontal
11022.03	32.85	43.60	14.30	39.50	10.20	43.05	68.20	-25.15	Pk	Vertical
11022.03	30.50	43.60	14.30	39.50	10.20	40.70	54.00	-13.30	AV	Vertical
11024.85	33.97	43.60	14.30	39.50	10.20	44.17	68.20	-24.03	Pk	Horizontal
11024.85	30.59	43.60	14.30	39.50	10.20	40.79	54.00	-13.21	AV	Horizontal
13288.64	31.90	42.60	15.90	38.90	12.20	44.10	68.20	-24.10	Pk	Vertical
13288.64	29.66	42.60	15.90	38.90	12.20	41.86	54.00	-12.14	AV	Vertical
13296.55	32.49	42.60	15.90	38.90	12.20	44.69	68.20	-23.51	Pk	Horizontal
13296.55	29.16	42.60	15.90	38.90	12.20	41.36	54.00	-12.64	AV	Horizontal

Remark:

- Factor = Antenna Factor + Cable Loss – Pre-amplifier.
- Scan with 802.11a,802.11n (HT-20),802.11n (HT-40), 802.11ac (VHT-20),802.11ac (VHT-40), 802.11ac (VHT-80) the worst case is 802.11n (HT-20).
- The frequency emission of peak points that did not show above the forms are at least 20dB below the limit, the frequency emission is mainly from the environment noise.



Band IV(5.725-5.850) GHz

Frequency (MHz)	Reading	Amplifier	Loss	Antenna Factor	Orrected Factor	Emission Level	Limit (dBuV/m)	Margin	Detector	Comment
	(dBuV)	(dB)	(dB)	(dB/m)	(dB)	(dBuV/m)		(dB)		
Low Channel (802.11/ 5745 MHz)										
3252.72	44.70	44.70	6.70	28.20	-9.80	34.90	68.20	-33.30	Pk	Vertical
3252.72	40.90	44.70	6.70	28.20	-9.80	31.10	54.00	-22.90	AV	Vertical
3256.67	44.29	44.70	6.70	28.20	-9.80	34.49	68.20	-33.71	Pk	Horizontal
3256.67	41.68	44.70	6.70	28.20	-9.80	31.88	54.00	-22.12	AV	Horizontal
3993.95	38.76	44.20	7.90	29.70	-6.60	32.16	68.20	-36.04	Pk	Vertical
3993.95	37.03	44.20	7.90	29.70	-6.60	30.43	54.00	-23.57	AV	Vertical
3987.35	39.32	44.20	7.90	29.70	-6.60	32.72	68.20	-35.48	Pk	Horizontal
3987.35	37.06	44.20	7.90	29.70	-6.60	30.46	54.00	-23.54	AV	Horizontal
7231.66	37.42	43.50	11.40	35.50	3.40	40.82	68.20	-27.38	Pk	Vertical
7231.66	33.67	43.50	11.40	35.50	3.40	37.07	54.00	-16.93	AV	Vertical
7220.81	37.24	43.50	11.40	35.50	3.40	40.64	68.20	-27.56	Pk	Horizontal
7220.81	34.84	43.50	11.40	35.50	3.40	38.24	54.00	-15.76	AV	Horizontal
10360.32	40.05	44.50	13.80	38.80	8.10	48.15	68.20	-20.05	Pk	Vertical
10360.32	35.77	44.50	13.80	38.80	8.10	43.87	54.00	-10.13	AV	Vertical
10360.25	39.50	44.50	13.80	38.80	8.10	47.60	68.20	-20.60	Pk	Horizontal
10360.25	37.06	44.50	13.80	38.80	8.10	45.16	54.00	-8.84	AV	Horizontal
11026.16	34.10	43.60	14.30	39.50	10.20	44.30	68.20	-23.90	Pk	Vertical
11026.16	30.59	43.60	14.30	39.50	10.20	40.79	54.00	-13.21	AV	Vertical
11030.25	32.90	43.60	14.30	39.50	10.20	43.10	68.20	-25.10	Pk	Horizontal
11030.25	30.50	43.60	14.30	39.50	10.20	40.70	54.00	-13.30	AV	Horizontal
13296.04	32.40	42.60	15.90	38.90	12.20	44.60	68.20	-23.60	Pk	Vertical
13296.04	29.98	42.60	15.90	38.90	12.20	42.18	54.00	-11.82	AV	Vertical
13282.80	32.79	42.60	15.90	38.90	12.20	44.99	68.20	-23.21	Pk	Horizontal
13282.80	29.87	42.60	15.90	38.90	12.20	42.07	54.00	-11.93	AV	Horizontal
Mid Channel (802.11/ 5785MHz)										
3264.93	43.87	44.70	6.70	28.20	-9.80	34.07	68.20	-34.13	Pk	Vertical
3264.93	41.89	44.70	6.70	28.20	-9.80	32.09	54.00	-21.91	AV	Vertical
3256.29	44.92	44.70	6.70	28.20	-9.80	35.12	68.20	-33.08	Pk	Horizontal
3256.29	42.10	44.70	6.70	28.20	-9.80	32.30	54.00	-21.70	AV	Horizontal
3984.36	40.04	44.20	7.90	29.70	-6.60	33.44	68.20	-34.76	Pk	Vertical
3984.36	36.37	44.20	7.90	29.70	-6.60	29.77	54.00	-24.23	AV	Vertical
3996.21	38.65	44.20	7.90	29.70	-6.60	32.05	68.20	-36.15	Pk	Horizontal
3996.21	36.65	44.20	7.90	29.70	-6.60	30.05	54.00	-23.95	AV	Horizontal
7221.56	36.63	43.50	11.40	35.50	3.40	40.03	68.20	-28.17	Pk	Vertical
7221.56	34.89	43.50	11.40	35.50	3.40	38.29	54.00	-15.71	AV	Vertical
7229.51	37.05	43.50	11.40	35.50	3.40	40.45	68.20	-27.75	Pk	Horizontal
7229.51	34.68	43.50	11.40	35.50	3.40	38.08	54.00	-15.92	AV	Horizontal
10400.36	40.04	44.50	13.80	38.80	8.10	48.14	68.20	-20.06	Pk	Vertical
10400.36	37.14	44.50	13.80	38.80	8.10	45.24	54.00	-8.76	AV	Vertical
10400.41	40.14	44.50	13.80	38.80	8.10	48.24	68.20	-19.96	Pk	Horizontal
10400.41	36.51	44.50	13.80	38.80	8.10	44.61	54.00	-9.39	AV	Horizontal
11033.45	32.88	43.60	14.30	39.50	10.20	43.08	68.20	-25.12	Pk	Vertical
11033.45	30.84	43.60	14.30	39.50	10.20	41.04	54.00	-12.96	AV	Vertical
11019.03	32.87	43.60	14.30	39.50	10.20	43.07	68.20	-25.13	Pk	Horizontal
11019.03	31.06	43.60	14.30	39.50	10.20	41.26	54.00	-12.74	AV	Horizontal
13286.46	32.86	42.60	15.90	38.90	12.20	45.06	68.20	-23.14	Pk	Vertical
13286.46	29.26	42.60	15.90	38.90	12.20	41.46	54.00	-12.54	AV	Vertical
13288.77	31.88	42.60	15.90	38.90	12.20	44.08	68.20	-24.12	Pk	Horizontal
13288.77	29.63	42.60	15.90	38.90	12.20	41.83	54.00	-12.17	AV	Horizontal



High Channel (802.11/ 5825 MHz)										
3261.30	44.90	44.70	6.70	28.20	-9.80	35.10	68.20	-33.10	Pk	Vertical
3261.30	40.95	44.70	6.70	28.20	-9.80	31.15	54.00	-22.85	AV	Vertical
3247.98	44.63	44.70	6.70	28.20	-9.80	34.83	68.20	-33.37	Pk	Horizontal
3247.98	41.63	44.70	6.70	28.20	-9.80	31.83	54.00	-22.17	AV	Horizontal
3997.90	39.95	44.20	7.90	29.70	-6.60	33.35	68.20	-34.85	Pk	Vertical
3997.90	36.78	44.20	7.90	29.70	-6.60	30.18	54.00	-23.82	AV	Vertical
3988.24	39.87	44.20	7.90	29.70	-6.60	33.27	68.20	-34.93	Pk	Horizontal
3988.24	36.25	44.20	7.90	29.70	-6.60	29.65	54.00	-24.35	AV	Horizontal
7218.71	37.33	43.50	11.40	35.50	3.40	40.73	68.20	-27.47	Pk	Vertical
7218.71	33.61	43.50	11.40	35.50	3.40	37.01	54.00	-16.99	AV	Vertical
7225.99	36.63	43.50	11.40	35.50	3.40	40.03	68.20	-28.17	Pk	Horizontal
7225.99	33.87	43.50	11.40	35.50	3.40	37.27	54.00	-16.73	AV	Horizontal
10480.39	39.65	44.50	13.80	38.80	8.10	47.75	68.20	-20.45	Pk	Vertical
10480.39	36.19	44.50	13.80	38.80	8.10	44.29	54.00	-9.71	AV	Vertical
10480.18	38.69	44.50	13.80	38.80	8.10	46.79	68.20	-21.41	Pk	Horizontal
10480.18	35.79	44.50	13.80	38.80	8.10	43.89	54.00	-10.11	AV	Horizontal
11027.04	33.89	43.60	14.30	39.50	10.20	44.09	68.20	-24.11	Pk	Vertical
11027.04	30.50	43.60	14.30	39.50	10.20	40.70	54.00	-13.30	AV	Vertical
11032.04	33.68	43.60	14.30	39.50	10.20	43.88	68.20	-24.32	Pk	Horizontal
11032.04	30.19	43.60	14.30	39.50	10.20	40.39	54.00	-13.61	AV	Horizontal
13281.57	32.63	42.60	15.90	38.90	12.20	44.83	68.20	-23.37	Pk	Vertical
13281.57	28.94	42.60	15.90	38.90	12.20	41.14	54.00	-12.86	AV	Vertical
13296.78	31.81	42.60	15.90	38.90	12.20	44.01	68.20	-24.19	Pk	Horizontal
13296.78	29.94	42.60	15.90	38.90	12.20	42.14	54.00	-11.86	AV	Horizontal

Remark:

- Factor = Antenna Factor + Cable Loss – Pre-amplifier.
- Scan with 802.11a,802.11n (HT-20),802.11n (HT-40), 802.11ac (VHT-20),802.11ac (VHT-40), 802.11ac (VHT-80) the worst case is 802.11n (HT-20).
- The frequency emission of peak points that did not show above the forms are at least 20dB below the limit, the frequency emission is mainly from the environment noise.

3.2.9 Band Edge
Band I 5150-5250MHz

802.11a Low
Horizontal

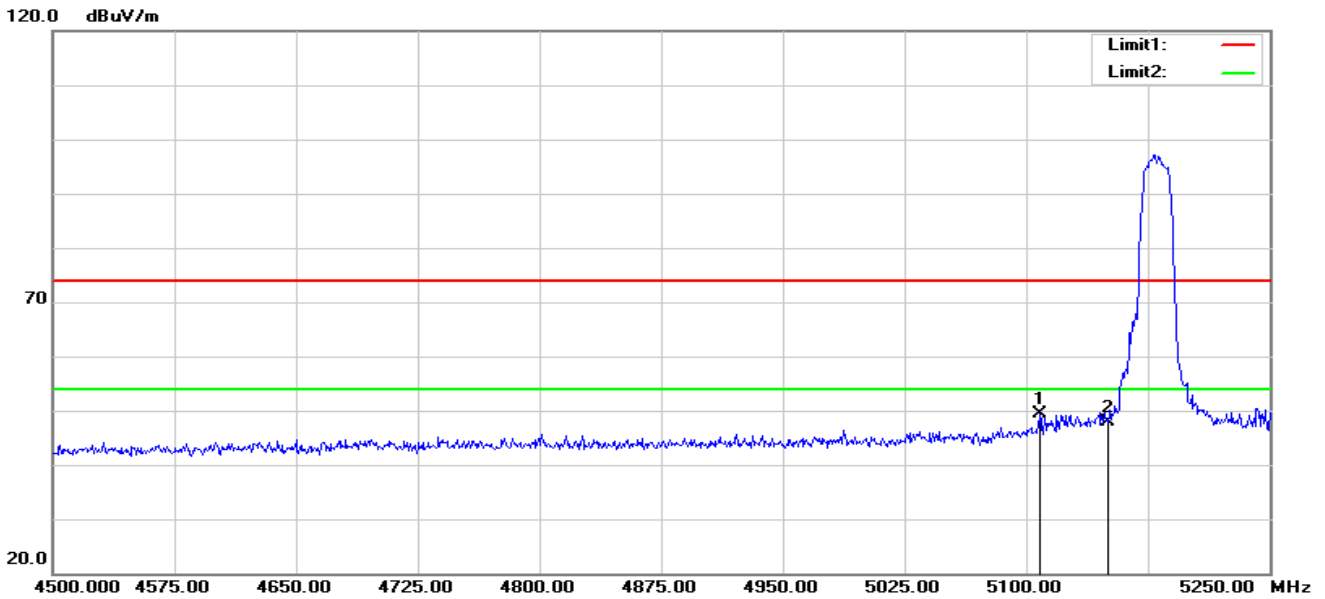

No.	Frequency (MHz)	Reading (dBuV)	Correct Factor(dB/m)	Result (dBuV/m)	Limit (dBuV/m)	Margin (dB)	Remark
1	5108.250	55.14	-5.74	49.40	74.00	-24.60	peak
2	5150.000	53.53	-5.73	47.80	74.00	-26.20	peak

Vertical

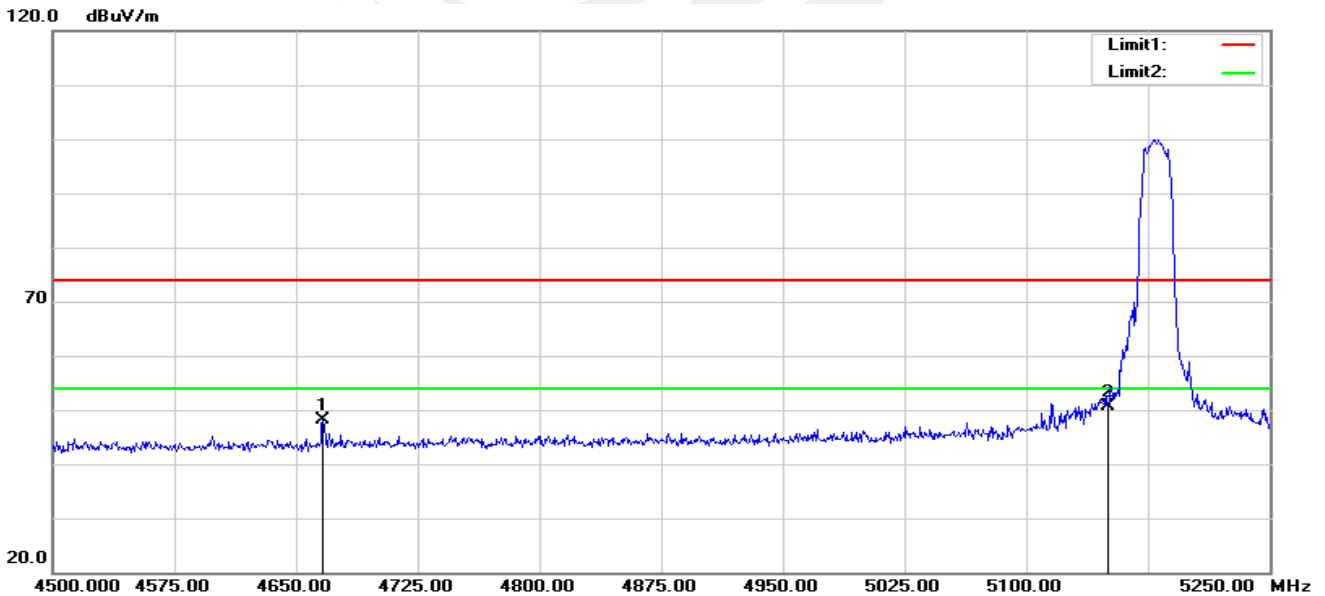

No.	Frequency (MHz)	Reading (dBuV)	Correct Factor(dB/m)	Result (dBuV/m)	Limit (dBuV/m)	Margin (dB)	Remark
1	4666.500	55.64	-7.53	48.11	74.00	-25.89	peak
2	5150.000	56.37	-5.73	50.64	74.00	-23.36	peak



802.11a High
Horizontal

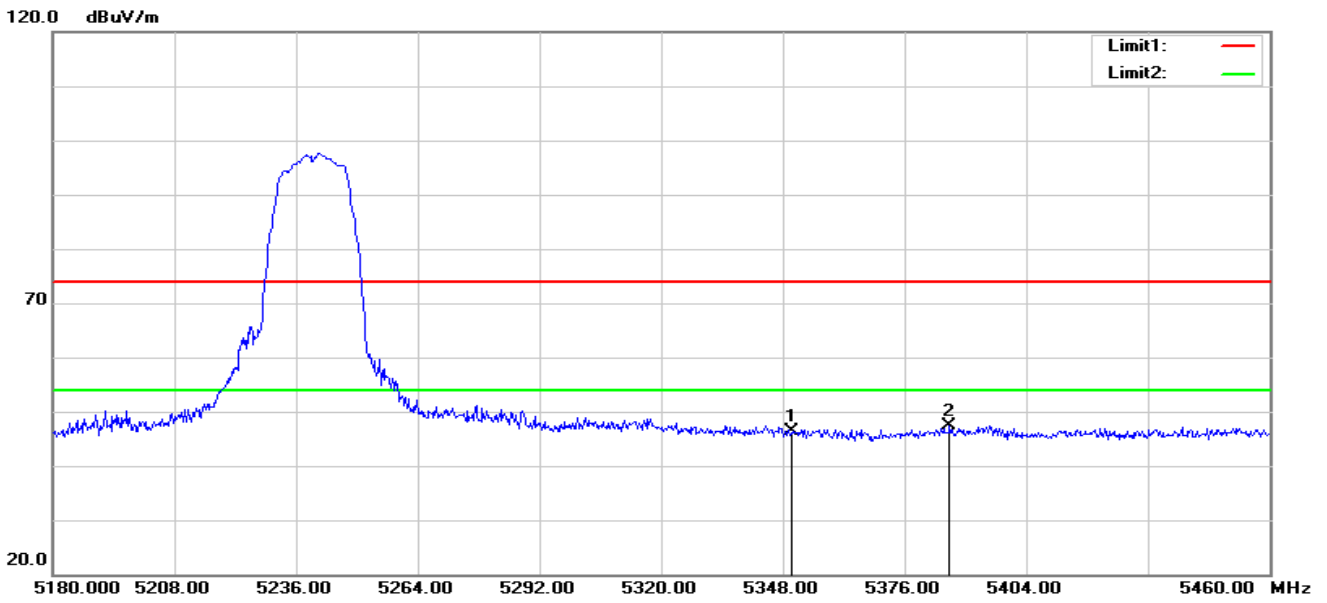

No.	Frequency (MHz)	Reading (dBuV)	Correct Factor(dB/m)	Result (dBuV/m)	Limit (dBuV/m)	Margin (dB)	Remark
1	5350.000	51.64	-5.23	46.41	74.00	-27.59	peak
2	5386.360	52.64	-5.24	47.40	74.00	-26.60	peak

Vertical

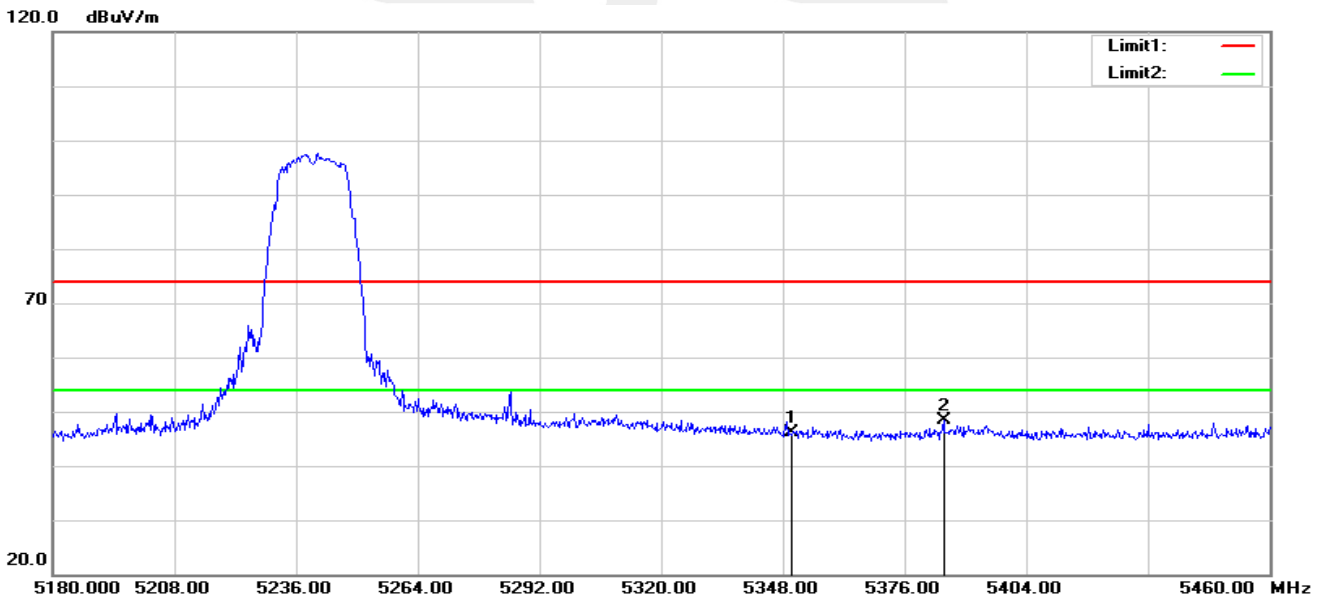

No.	Frequency (MHz)	Reading (dBuV)	Correct Factor(dB/m)	Result (dBuV/m)	Limit (dBuV/m)	Margin (dB)	Remark
1	5350.000	51.38	-5.23	46.15	74.00	-27.85	peak
2	5384.960	53.67	-5.24	48.43	74.00	-25.57	peak

Note: 802.11a,802.11n (HT-20),802.11n (HT-40), 802.11ac (VHT-20),802.11ac (VHT-40), 802.11ac (VHT-80) all has been tested, the worst case is 802.11a,only shown the worst case.



Band II 5250-5350MHz

802.11a Low
Horizontal

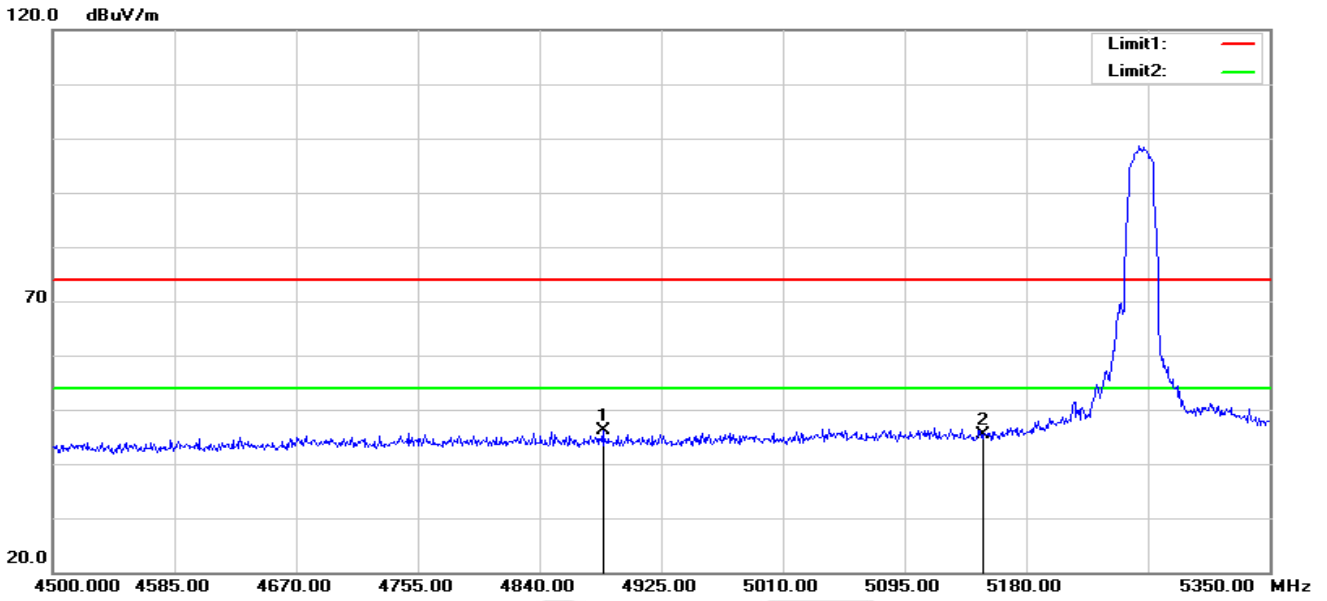

No.	Frequency (MHz)	Reading (dBuV)	Correct Factor(dB/m)	Result (dBuV/m)	Limit (dBuV/m)	Margin (dB)	Remark
1	4884.200	52.98	-6.90	46.08	74.00	-27.92	peak
2	5150.000	51.02	-5.73	45.29	74.00	-28.71	peak

Vertical

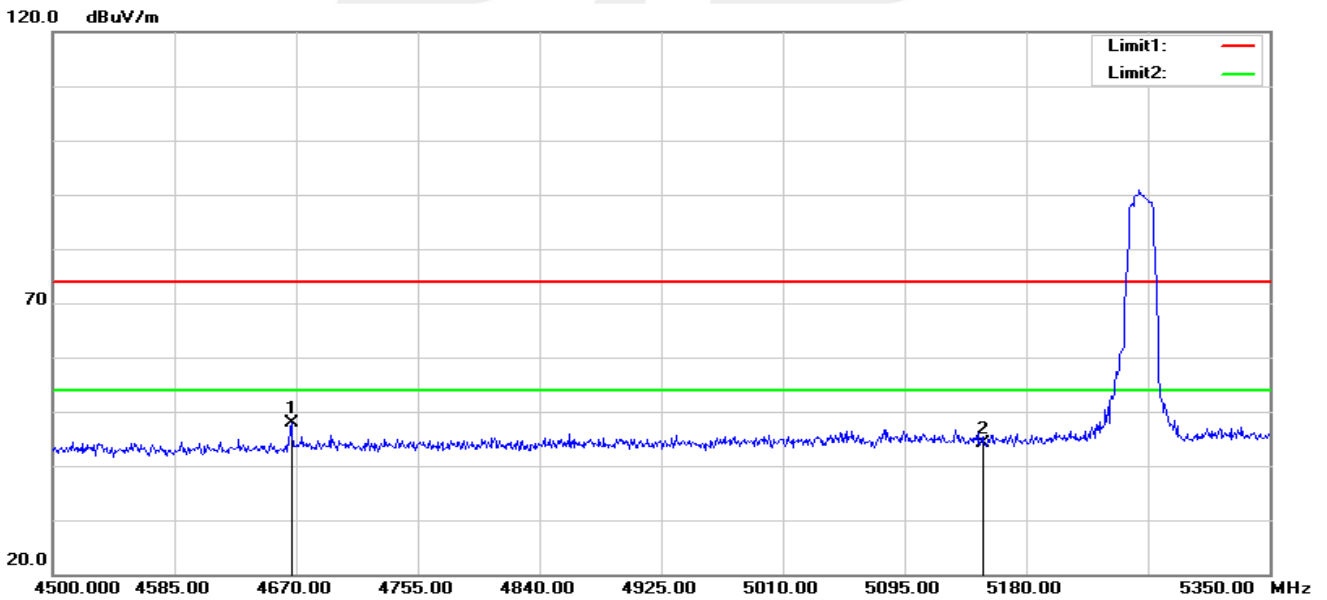

No.	Frequency (MHz)	Reading (dBuV)	Correct Factor(dB/m)	Result (dBuV/m)	Limit (dBuV/m)	Margin (dB)	Remark
1	4666.600	55.44	-7.53	47.91	74.00	-26.09	peak
2	5150.000	49.77	-5.73	44.04	74.00	-29.96	peak



802.11a High
Horizontal

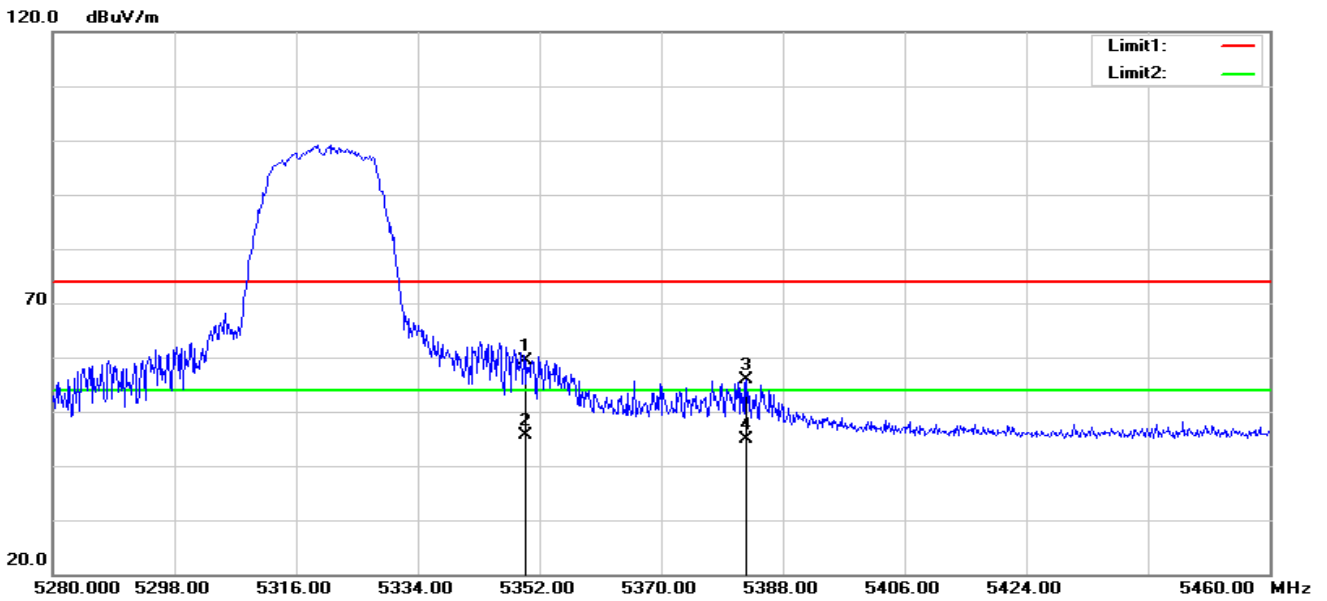

No.	Frequency (MHz)	Reading (dBuV)	Correct Factor(dB/m)	Result (dBuV/m)	Limit (dBuV/m)	Margin (dB)	Remark
1	5350.000	64.56	-5.23	59.33	74.00	-14.67	peak
2	5350.000	50.85	-5.23	45.62	54.00	-8.38	AVG
3	5382.600	61.12	-5.24	55.88	74.00	-18.12	peak
4	5382.600	50.09	-5.24	44.85	54.00	-9.15	AVG

Vertical

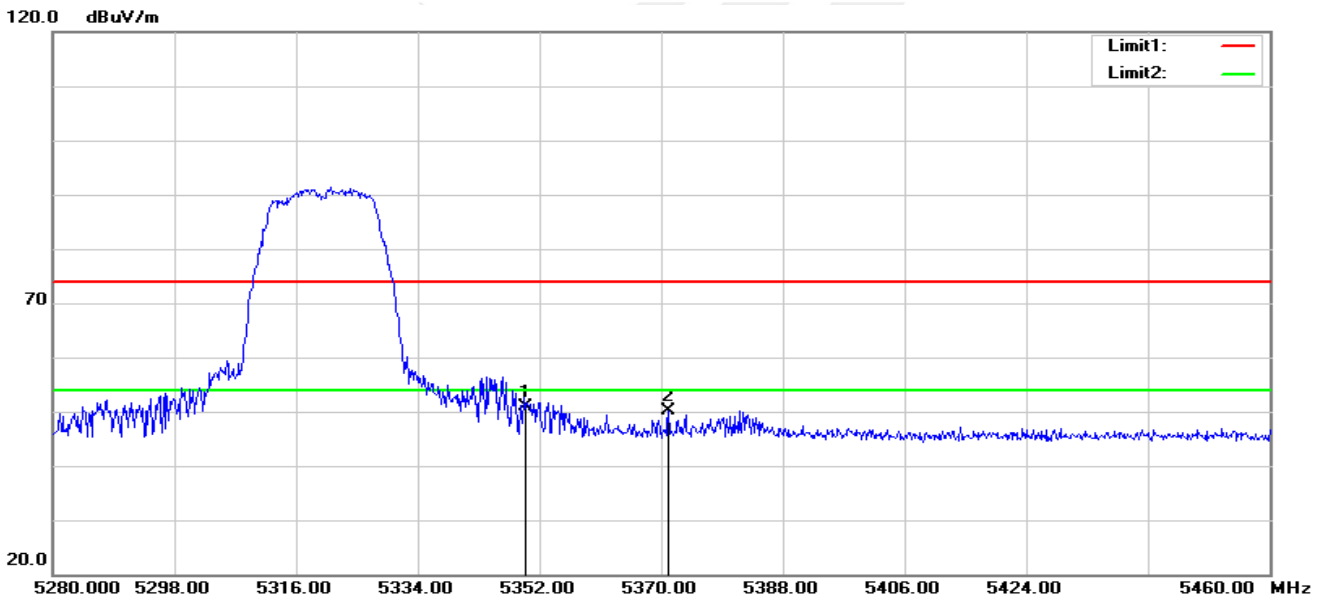

No.	Frequency (MHz)	Reading (dBuV)	Correct Factor(dB/m)	Result (dBuV/m)	Limit (dBuV/m)	Margin (dB)	Remark
1	5350.000	56.20	-5.23	50.97	74.00	-23.03	peak
2	5371.080	55.46	-5.24	50.22	74.00	-23.78	peak

Note: 802.11a,802.11n (HT-20),802.11n (HT-40), 802.11ac (VHT-20),802.11ac (VHT-40), 802.11ac (VHT-80) all has been tested, the worst case is 802.11a,only shown the worst case.



Band III 5470-5725MHz

**802.11a Low
Horizontal**

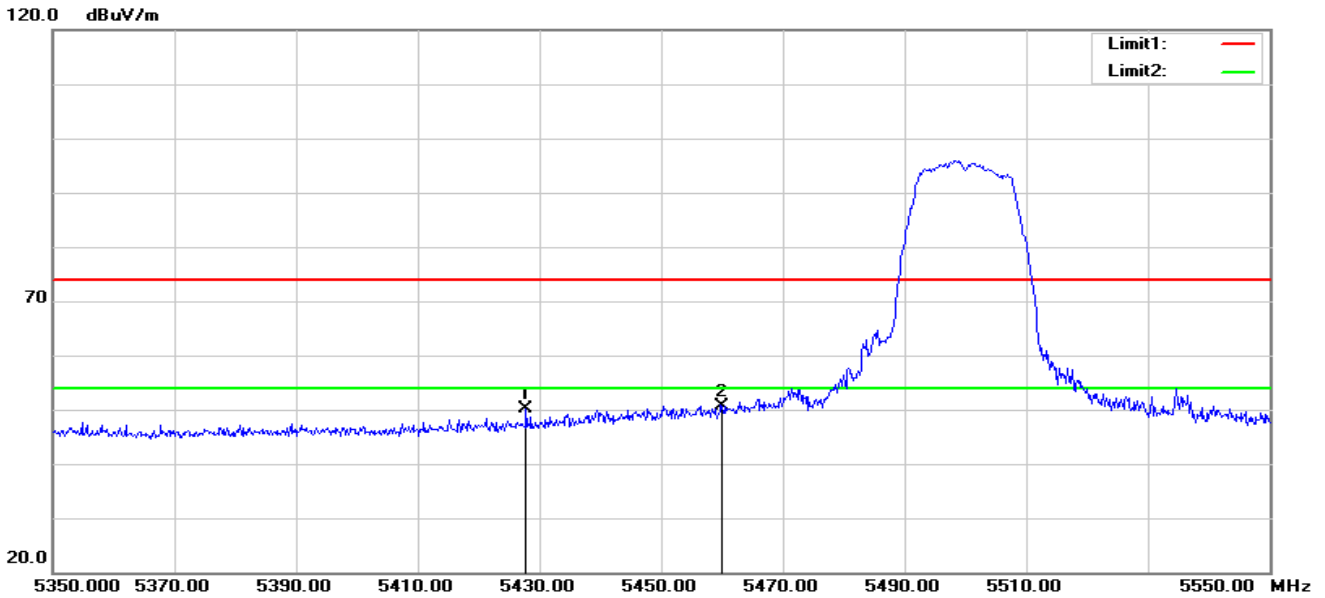

No.	Frequency (MHz)	Reading (dBuV)	Correct Factor(dB/m)	Result (dBuV/m)	Limit (dBuV/m)	Margin (dB)	Remark
1	5427.800	55.33	-5.19	50.14	74.00	-23.86	peak
2	5460.000	55.78	-5.11	50.67	74.00	-23.33	peak

Vertical

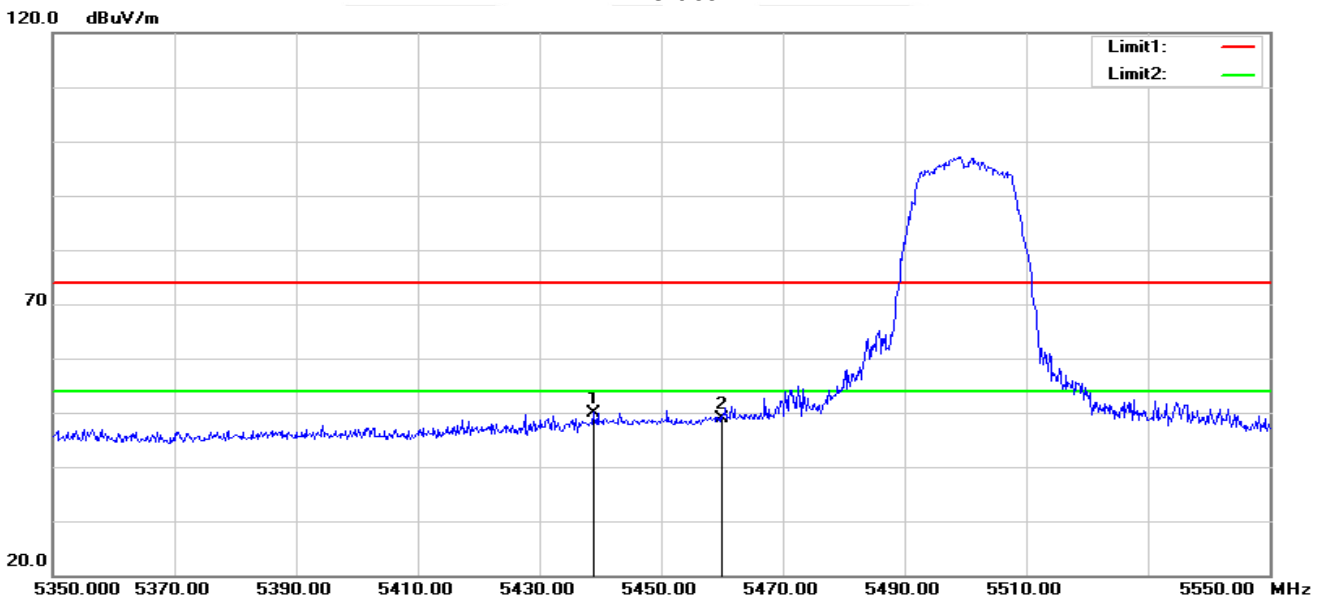

No.	Frequency (MHz)	Reading (dBuV)	Correct Factor(dB/m)	Result (dBuV/m)	Limit (dBuV/m)	Margin (dB)	Remark
1	5438.800	55.16	-5.16	50.00	74.00	-24.00	peak
2	5460.000	54.09	-5.11	48.98	74.00	-25.02	peak

Note: 1. 802.11a,802.11n (HT-20),802.11n (HT-40), 802.11ac (VHT-20),802.11ac (VHT-40), 802.11ac (VHT-80) all has been tested, the worst case is 802.11a,only shown the worst case.

2. The high channel main frequency is too far away from the restricted band and does not require testing.

Band IV(5.725-5.85 GHz)

Note: The main frequency is too far away from the restricted band and does not require testing.



4. CONDUCTED SPURIOUS EMISSIONS AND BANDEDGE

4.1 LIMIT

Undesirable emission limits. Except as shown in paragraph (b)(7) of this section, the maximum emissions outside of the frequency bands of operation shall be attenuated in accordance with the following limits:

- (1) For transmitters operating in the 5.15-5.25 GHz band: All emissions outside of the 5.15-5.35 GHz band shall not exceed an e.i.r.p. of -27 dBm/MHz.
- (2) For transmitters operating in the 5.25-5.35 GHz band: All emissions outside of the 5.15-5.35 GHz band shall not exceed an e.i.r.p. of -27 dBm/MHz.
- (3) For transmitters operating in the 5.47-5.725 GHz band: All emissions outside of the 5.47-5.725 GHz band shall not exceed an e.i.r.p. of -27 dBm/MHz.
- (4) For transmitters operating in the 5.725-5.85 GHz band:
 - (i) All emissions shall be limited to a level of -27 dBm/MHz at 75 MHz or more above or below the band edge increasing linearly to 10 dBm/MHz at 25 MHz above or below the band edge, and from 25 MHz above or below the band edge increasing linearly to a level of 15.6 dBm/MHz at 5 MHz above or below the band edge, and from 5 MHz above or below the band edge increasing linearly to a level of 27 dBm/MHz at the band edge.

4.2 TEST PROCEDURE

Spectrum Parameter	Setting
Detector	Peak
Start/Stop Frequency	30 MHz to 10th carrier harmonic
RB / VB (emission in restricted band)	1000 KHz/3000 KHz
Trace-Mode:	Max hold

For Band edge

Spectrum Parameter	Setting
Detector	Peak
Start/Stop Frequency	Lower Band Edge: 5700 to 5725 MHz Upper Band Edge: 5850 to 5870 MHz
RB / VB (emission in restricted band)	1000 KHz/3000 KHz
Trace-Mode:	Max hold

4.3 DEVIATION FROM STANDARD

No deviation.

4.4 TEST SETUP

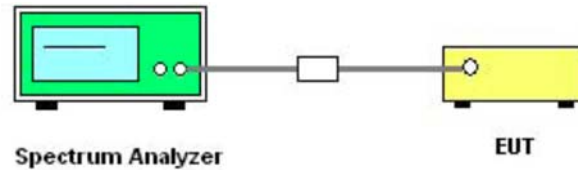

The EUT which is powered by the Battery, is coupled to the Spectrum Analyzer; the RF load attached to the EUT antenna terminal is 50Ohm; the path loss as the factor is calibrated to correct the reading.

Make the measurement with the spectrum analyzer's resolution bandwidth (RBW) = 1000 kHz. In order to make an accurate measurement, set the span greater than RBW.

4.5 EUT OPERATION CONDITIONS

The EUT tested system was configured as the statements of 2.3 Unless otherwise a special operating condition is specified in the follows during the testing.

4.6 TEST RESULTS

Data See Attachment A





5. POWER SPECTRAL DENSITY TEST

5.1 LIMIT

1. For mobile and portable client devices in the 5.15-5.25 GHz band, , the maximum power spectral density shall not exceed 11 dBm in any 1 megahertz band. If transmitting antennas of directional gain greater than 6 dBi are used, both the maximum conducted output power and the maximum power spectral density shall be reduced by the amount in dB that the directional gain of the antenna exceeds 6 dBi.
2. For the 5.25-5.35 GHz and 5.47-5.725 GHz bands, the maximum power spectral density shall not exceed 11 dBm in any 1 megahertz band. If transmitting antennas of directional gain greater than 6 dBi are used, both the maximum conducted output power and the maximum power spectral density shall be reduced by the amount in dB that the directional gain of the antenna exceeds 6 dBi.
3. For the band 5.725-5.850 GHz, the peak power spectral density shall not exceed 30 dBm in any 500KHz band. If transmitting antenna directional gain is greater than 6 dBi, both the maximum conducted output power and the peak power spectral density shall be reduced by the amount in dB that the directional gain of the antenna exceeds 6 dBi.

5.2 TEST PROCEDURE

1. The setting follows Method SA-1 of FCC KDB 789033 D02 General U-NII Test Procedures New Rules v02r01.

For devices operating in the band, the rules specify a measurement bandwidth of 500 kHz.

Many spectrum analyzers do not have 500 kHz RBW, thus a narrower RBW may need to be used.

The rules permit the use of a RBWs less than 1 MHz, or 500 kHz, "provided that the measured power is integrated over the full reference bandwidth" to show the total power over the specified measurement bandwidth (*i.e.*, 1 MHz, or 500 kHz). If measurements are performed using a reduced resolution bandwidth (< 1 MHz, or < 500 kHz) and integrated over 1 MHz, or 500 KHz bandwidth, the following adjustments to the procedures apply:

- a) Set $RBW \geq 1/T$, where T is defined in section II.B.I.a).
- b) Set $VBW \geq 3 RBW$.
- c) If measurement bandwidth of Maximum PSD is specified in 500 kHz, add $10 \log (500\text{kHz}/RBW)$ to the measured result, whereas $RBW (< 500 \text{ kHz})$ is the reduced resolution bandwidth of the spectrum analyzer set during measurement.
- d) If measurement bandwidth of Maximum PSD is specified in 1 MHz, add $10 \log (1\text{MHz}/RBW)$ to the measured result, whereas $RBW (< 1 \text{ MHz})$ is the reduced resolution bandwidth of spectrum analyzer set during measurement.
- e) Care must be taken to ensure that the measurements are performed during a period of continuous transmission or are corrected upward for duty cycle.

Note: As a practical matter, it is recommended to use reduced RBW of 100 kHz for the sections 5.c) and 5.d) above, since $RBW=100 \text{ KHZ}$ is available on nearly all spectrum analyzers.



5.3 DEVIATION FROM STANDARD

No deviation.

5.4 TEST SETUP



5.5 EUT OPERATION CONDITIONS

The EUT tested system was configured as the statements of 2.1 Unless otherwise a special operating condition is specified in the follows during the testing.

5.6 TEST RESULTS

5150-5250MHz									
Frequency	Ant_A Power Density (dBm)	Ant_B Power Density (dBm)	Ant_A Duty cycle factor	Ant_B Duty cycle factor	Ant_A Power Density (dBm)	Ant_B Power Density (dBm)	Power Density Total (dBm)	Limit	Result
802.11a									
5180	0.856	0.760	0.086	0.086	0.942	0.846	--	11	PASS
5200	1.373	1.040	0.086	0.086	1.459	1.126	--	11	PASS
5240	0.619	0.457	0.086	0.086	0.705	0.543	--	11	PASS
802.11n20									
5180	-2.307	-2.437	0.104	0.104	-2.203	-2.333	0.743	11	PASS
5200	-2.140	-2.015	0.104	0.104	-2.036	-1.911	1.037	11	PASS
5240	-3.059	-2.962	0.104	0.104	-2.955	-2.858	0.104	11	PASS
802.11n40									
5190	-5.977	-6.796	0.220	0.220	-5.757	-6.576	-3.137	11	PASS
5230	-5.964	-6.386	0.220	0.220	-5.744	-6.166	-2.939	11	PASS
802.11ac20									
5180	-2.426	-2.485	0.090	0.090	-2.336	-2.395	0.645	11	PASS
5200	-2.168	-1.973	0.090	0.090	-2.078	-1.883	1.031	11	PASS
5240	-2.602	-2.730	0.090	0.090	-2.512	-2.640	0.435	11	PASS
802.11ac40									
5190	-5.707	-0.295	0.204	0.204	-5.503	-0.091	1.007	11	PASS
5230	-6.158	-0.878	0.204	0.204	-5.954	-0.674	0.454	11	PASS
802.11ac80									
5210	-8.642	-9.523	0.438	0.438	-8.204	-9.085	-5.612	11	PASS



5250-5350MHz									
Frequency	Ant_A Power Density (dBm)	Ant_B Power Density (dBm)	Ant_A Duty cycle factor	Ant_B Duty cycle factor	Ant_A Power Density (dBm)	Ant_B Power Density (dBm)	Power Density Total (dBm)	Limit	Result
802.11a									
5260	0.621	1.124	0.061	0.061	0.682	1.185	--	11	PASS
5300	0.951	1.468	0.061	0.061	1.012	1.529	--	11	PASS
5320	0.427	0.837	0.061	0.061	0.488	0.898	--	11	PASS
802.11n20									
5260	0.388	-3.910	0.104	0.104	0.492	-3.806	1.865	11	PASS
5300	0.754	-1.975	0.104	0.104	0.858	-1.871	2.715	11	PASS
5320	0.213	-2.268	0.104	0.104	0.317	-2.164	2.262	11	PASS
802.11n40									
5270	-6.209	-6.179	0.233	0.233	-5.976	-5.946	-2.950	11	PASS
5310	-5.383	-5.622	0.233	0.233	-5.150	-5.389	-2.257	11	PASS
802.11ac20									
5260	-2.019	-2.418	0.104	0.104	-1.915	-2.314	0.900	11	PASS
5300	-1.835	-1.872	0.104	0.104	-1.731	-1.768	1.261	11	PASS
5320	-2.266	-2.442	0.104	0.104	-2.162	-2.338	0.761	11	PASS
802.11ac40									
5270	-5.572	-5.996	0.230	0.230	-5.342	-5.766	-2.539	11	PASS
5310	-5.417	-5.679	0.230	0.230	-5.187	-5.449	-2.306	11	PASS
802.11ac80									
5290	-8.767	-8.591	0.451	0.451	-8.316	-8.140	-5.217	11	PASS

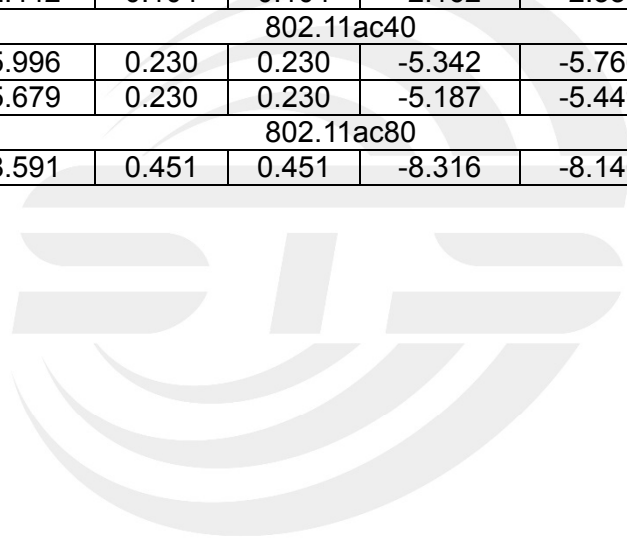



5470-5725MHz									
Frequency	Ant_A Power Density (dBm)	Ant_B Power Density (dBm)	Ant_A Duty cycle factor	Ant_B Duty cycle factor	Ant_A Power Density (dBm)	Ant_B Power Density (dBm)	Power Density Total (dBm)	Limit	Result
802.11a									
5500	0.593	0.498	0.086	0.086	0.679	0.584	--	11	PASS
5580	0.882	0.796	0.086	0.086	0.968	0.882	--	11	PASS
5700	0.261	0.570	0.086	0.086	0.347	0.656	--	11	PASS
802.11n20									
5500	-2.479	-2.425	0.104	0.104	-2.375	-2.321	0.663	11	PASS
5580	-2.454	-2.465	0.104	0.104	-2.350	-2.361	0.655	11	PASS
5700	-2.931	-2.918	0.104	0.104	-2.827	-2.814	0.190	11	PASS
802.11n40									
5510	-6.172	-5.947	0.219	0.219	-5.953	-5.728	-2.828	11	PASS
5550	-6.106	-6.797	0.219	0.219	-5.887	-6.578	-3.208	11	PASS
5670	-6.127	-5.712	0.219	0.219	-5.908	-5.493	-2.685	11	PASS
802.11ac20									
5500	-2.877	-2.624	0.091	0.091	-2.786	-2.533	0.352	11	PASS
5580	-2.483	-2.814	0.091	0.091	-2.392	-2.723	0.456	11	PASS
5700	-2.624	-2.918	0.091	0.091	-2.533	-2.827	0.332	11	PASS
802.11ac40									
5510	-5.782	-6.434	0.230	0.230	-5.552	-6.204	-2.856	11	PASS
5550	-6.356	-6.895	0.230	0.230	-6.126	-6.665	-3.377	11	PASS
5670	-4.998	-5.875	0.230	0.230	-4.768	-5.645	-2.174	11	PASS
802.11ac80									
5530	-9.848	-10.637	0.451	0.451	-9.397	-10.186	-6.763	11	PASS
5610	-9.626	-9.543	0.451	0.451	-9.175	-9.092	-6.123	11	PASS



5725-5850MHz									
Frequency	Ant_A Power Density (dBm)	Ant_B Power Density (dBm)	Ant_A Duty cycle factor	Ant_B Duty cycle factor	Ant_A Power Density (dBm)	Ant_B Power Density (dBm)	Power Density Total (dBm)	Limit	Result
802.11a									
5745	0.391	0.227	0.086	0.086	0.477	0.313	--	30	PASS
5785	0.936	1.124	0.086	0.086	1.022	1.210	--	30	PASS
5825	0.546	0.885	0.086	0.086	0.632	0.971	--	30	PASS
802.11n20									
5745	-2.935	-3.266	0.104	0.104	-2.831	-3.162	0.017	30	PASS
5785	-2.246	-2.534	0.104	0.104	-2.142	-2.430	0.727	30	PASS
5825	-2.928	-2.932	0.104	0.104	-2.824	-2.828	0.185	30	PASS
802.11n40									
5755	-5.766	-5.535	0.233	0.233	-5.533	-5.302	-2.406	30	PASS
5795	-5.905	-5.896	0.233	0.233	-5.672	-5.663	-2.657	30	PASS
802.11ac20									
5745	-2.409	-3.200	0.065	0.065	-2.344	-3.135	0.288	30	PASS
5785	-2.309	-2.418	0.065	0.065	-2.244	-2.353	0.712	30	PASS
5825	-2.736	-2.937	0.065	0.065	-2.671	-2.872	0.239	30	PASS
802.11ac40									
5755	-5.569	-5.239	0.230	0.230	-5.339	-5.009	-2.161	30	PASS
5795	-6.130	-5.853	0.230	0.230	-5.900	-5.623	-2.749	30	PASS
802.11ac80									
5775	-8.152	-8.389	0.451	0.451	-7.701	-7.938	-4.808	30	PASS

Data see Attachment B

6. BANDWIDTH MEASUREMENT

6.1 EMISSION BANDWIDTH (EBW) 26 BANDWID PROCEDURES / LIMIT

The following procedure shall be used for measuring 26 bandwidth.

6.1.1 TEST PROCEDURE

1. The testing follows FCC KDB 789033 D02 General UNII Test Procedures New Rules v02r01.
2. Set RBW = approximately 1% of the emission bandwidth.
3. Set the VBW \geq RBW.
4. Detector = Peak.
5. Trace mode = max hold.
6. Measure the maximum width of the emission that is 26 dB down from the peak of the emission. Compare this with the RBW setting of the analyzer. Readjust RBW and repeat measurement as needed until the RBW/EBW ratio is approximately 1%.

6.1.2 DEVIATION FROM STANDARD

No deviation.

6.1.3 TEST SETUP



6.1.4 EUT OPERATION CONDITIONS

The EUT tested system was configured as the statements of 2.4 Unless otherwise a special operating condition is specified in the follows during the testing.



6.1.5 TEST RESULTS

Frequency (MHz)	26dB Bandwidth (MHz)	Pass/Fail
802.11a		
5180	21.08	Pass
5200	21.01	Pass
5240	21.10	Pass
802.11n(HT20)		
5180	21.37	Pass
5200	21.36	Pass
5240	21.27	Pass
802.11n(HT40)		
5190	40.12	Pass
5230	39.47	Pass
802.11ac(VHT20)		
5180	21.18	Pass
5200	21.29	Pass
5240	21.41	Pass
802.11ac(VHT40)		
5190	39.74	Pass
5230	39.39	Pass
802.11ac(VHT80)		
5210	80.86	Pass

Frequency (MHz)	26dB Bandwidth (MHz)	Pass/Fail
802.11a		
5260	21.13	Pass
5300	21.15	Pass
5320	20.92	Pass
802.11n(HT20)		
5260	21.15	Pass
5300	21.25	Pass
5320	21.36	Pass
802.11n(HT40)		
5270	39.85	Pass
5310	39.37	Pass
802.11ac(VHT20)		
5260	26.00	Pass
5300	21.43	Pass
5320	21.26	Pass
802.11ac(VHT40)		
5270	39.85	Pass
5310	39.63	Pass
802.11ac(VHT80)		
5290	81.01	Pass



Frequency (MHz)	26dB Bandwidth (MHz)	Pass/Fail
802.11a		
5500	21.22	Pass
5580	21.10	Pass
5700	21.24	Pass
802.11n(HT20)		
5500	21.33	Pass
5580	21.28	Pass
5700	21.44	Pass
802.11n(HT40)		
5510	39.55	Pass
5550	39.94	Pass
5670	39.71	Pass
802.11ac(VHT20)		
5500	21.59	Pass
5580	21.23	Pass
5700	21.47	Pass
802.11ac(VHT40)		
5510	39.73	Pass
5550	39.62	Pass
5670	39.47	Pass
802.11ac(VHT80)		
5530	83.79	Pass
5610	88.25	Pass

Frequency (MHz)	26dB Bandwidth (MHz)	Pass/Fail
802.11a		
5745	21.14	Pass
5785	21.10	Pass
5825	21.06	Pass
802.11n(HT20)		
5745	21.46	Pass
5785	21.40	Pass
5825	21.27	Pass
802.11n(HT40)		
5755	39.83	Pass
5795	39.43	Pass
802.11ac(VHT20)		
5745	21.39	Pass
5785	21.41	Pass
5825	21.23	Pass
802.11ac(VHT40)		
5755	39.52	Pass
5795	39.61	Pass
802.11ac(VHT80)		
5775	80.52	Pass

Test plot see Attachment C

6.2 OCCUPIED BANDWIDTH (99%) TEST APPLIED PROCEDURES / LIMIT

The following procedure shall be used for measuring (99 %) power bandwidth.

6.2.1 TEST PROCEDURE

1. The testing follows FCC KDB 789033 D02 General UNII Test Procedures v02r01.

The following procedure shall be used for measuring (99 %) power bandwidth:

1. Set center frequency to the nominal EUT channel center frequency.
2. Set span = 1.5 times to 5.0 times the OBW.
3. Set RBW = 1 % to 5 % of the OBW
4. Set VBW $\geq 3 \cdot$ RBW
5. Video averaging is not permitted. Where practical, a sample detection and single sweep mode shall be used. Otherwise, peak detection and max hold mode (until the trace stabilizes) shall be used.
6. Use the 99 % power bandwidth function of the instrument (if available).
7. If the instrument does not have a 99 % power bandwidth function, the trace data points are recovered and directly summed in power units. The recovered amplitude data points, beginning at the lowest frequency, are placed in a running sum until 0.5 % of the total is reached; that frequency is recorded as the lower frequency. The process is repeated until 99.5 % of the total is reached; that frequency is recorded as the upper frequency. The 99% occupied bandwidth is the difference between these two frequencies.

6.2.2 DEVIATION FROM STANDARD

No deviation.

6.2.3 TEST SETUP

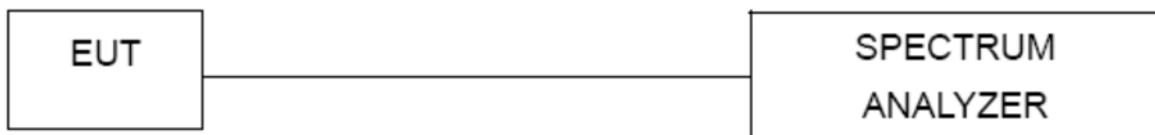

6.2.4 EUT OPERATION CONDITIONS

The EUT tested system was configured as the statements of 2.4 Unless otherwise a special operating condition is specified in the follows during the testing.

**6.2.5 TEST RESULTS**

Frequency (MHz)	99% Bandwidth (MHz)	Pass/Fail
802.11a		
5180	16.59	Pass
5200	16.60	Pass
5240	16.57	Pass
802.11n(HT20)		
5180	17.75	Pass
5200	17.76	Pass
5240	17.72	Pass
802.11n(HT40)		
5190	36.26	Pass
5230	36.11	Pass
802.11ac(VHT20)		
5180	17.74	Pass
5200	17.74	Pass
5240	17.74	Pass
802.11ac(VHT40)		
5190	36.19	Pass
5230	36.14	Pass
802.11ac(VHT80)		
5210	75.64	Pass

Frequency (MHz)	99% Bandwidth (MHz)	Pass/Fail
802.11a		
5260	16.58	Pass
5300	16.59	Pass
5320	16.57	Pass
802.11n(HT20)		
5260	17.77	Pass
5300	17.76	Pass
5320	17.71	Pass
802.11n(HT40)		
5270	36.23	Pass
5310	36.16	Pass
802.11ac(VHT20)		
5260	18.02	Pass
5300	17.75	Pass
5320	17.71	Pass
802.11ac(VHT40)		
5270	36.24	Pass
5310	36.13	Pass
802.11ac(VHT80)		
5290	75.56	Pass



Frequency (MHz)	99% Bandwidth (MHz)	Pass/Fail
802.11a		
5500	16.57	Pass
5580	16.56	Pass
5700	16.60	Pass
802.11n(HT20)		
5500	17.73	Pass
5580	17.71	Pass
5700	17.74	Pass
802.11n(HT40)		
5510	36.17	Pass
5550	36.22	Pass
5670	36.22	Pass
802.11ac(VHT20)		
5500	17.73	Pass
5580	17.71	Pass
5700	17.79	Pass
802.11ac(VHT40)		
5510	36.14	Pass
5550	36.21	Pass
5670	36.07	Pass
802.11ac(VHT80)		
5530	75.59	Pass
5610	75.44	Pass

Frequency (MHz)	99% Bandwidth (MHz)	Pass/Fail
802.11a		
5745	16.60	Pass
5785	16.59	Pass
5825	16.60	Pass
802.11n(HT20)		
5745	17.74	Pass
5785	17.76	Pass
5825	17.75	Pass
802.11n(HT40)		
5755	36.11	Pass
5795	36.20	Pass
802.11ac(VHT20)		
5745	17.71	Pass
5785	17.75	Pass
5825	17.73	Pass
802.11ac(VHT40)		
5755	36.12	Pass
5795	36.21	Pass
802.11ac(VHT80)		
5775	75.44	Pass

Test plot See Attachment C

6.3 MINIMUM EMISSION BANDWIDTH(6 DB) PROCEDURES / LIMIT

Section 15.407(e) specifies the minimum 6 dB emission bandwidth of at least 500 KHz for the band 5.725-5.85 GHz. The following procedure shall be used for measuring this bandwidth.

6.3.1 TEST PROCEDURE

1. The testing follows FCC KDB 789033 D02 General UNII Test Procedures v02r01.
 - a) Set RBW = 100 kHz.
 - b) Set the video bandwidth (VBW) $\geq 3 \times$ RBW.
 - c) Detector = Peak.
 - d) Trace mode = max hold.
 - e) Sweep = auto couple.
 - f) Allow the trace to stabilize.
 - g) Measure the maximum width of the emission that is constrained by the frequencies associated with the two outermost amplitude points (upper and lower frequencies) that are attenuated by 6 dB relative to the maximum level measured in the fundamental emission.

6.3.2 DEVIATION FROM STANDARD

No deviation.

6.3.3 TEST SETUP



6.3.4 EUT OPERATION CONDITIONS

The EUT tested system was configured as the statements of 2.4 Unless otherwise a special operating condition is specified in the follows during the testing.

**6.3.5 TEST RESULTS**

Frequency (MHz)	6dB Bandwidth (MHz)	Pass/Fail
802.11a		
5745	16.31	Pass
5785	16.32	Pass
5825	16.32	Pass
802.11n(HT20)		
5745	17.18	Pass
5785	17.60	Pass
5825	17.56	Pass
802.11n(HT40)		
5755	36.05	Pass
5795	36.36	Pass
802.11ac(VHT20)		
5745	17.18	Pass
5785	17.58	Pass
5825	17.57	Pass
802.11ac(VHT40)		
5755	35.95	Pass
5795	36.35	Pass
802.11ac(VHT80)		
5775	75.27	Pass

Test plots see Attachment D

7. MAXIMUM CONDUCTED OUTPUT POWER

7.1 LIMIT

For mobile and portable client devices in the 5.15-5.25 GHz band, the maximum conducted output power over the frequency band of operation shall not exceed 250 mW provided the maximum antenna gain does not exceed 6 dBi. If transmitting antennas of directional gain greater than 6 dBi are used, both the maximum conducted output power and the maximum power spectral density shall be reduced by the amount in dB that the directional gain of the antenna exceeds 6 dBi.

For the 5.25-5.35 GHz and 5.47-5.725 GHz bands, the maximum conducted output power over the frequency bands of operation shall not exceed the lesser of 250 mW or 11 dBm + 10 log B, where B is the 26 dB emission bandwidth in megahertz, If transmitting antennas of directional gain greater than 6 dBi are used.

For the band 5.725-5.85 GHz, the maximum conducted output power over the frequency band of operation shall not exceed 1 W. If transmitting antennas of directional gain greater than 6 dBi are used.

FCC Part15 (15.407) , Subpart E				
Section	Test Item	Limit	Frequency Range (MHz)	Result
15.407(a) (1) (iv)	Peak Output Power	0.25 watt	5150-5250	PASS
		The lesser of 250 mW or 11 dBm + 10 log (26 dB emission bandwidth)	5250-5350	
5470-5725				
15.407(a) (3)		1 watt	5725-5825	

7.2 TEST PROCEDURE

The EUT was directly connected to the Power Sensor&PC

7.3 DEVIATION FROM STANDARD

No deviation.

7.4 TEST SETUP

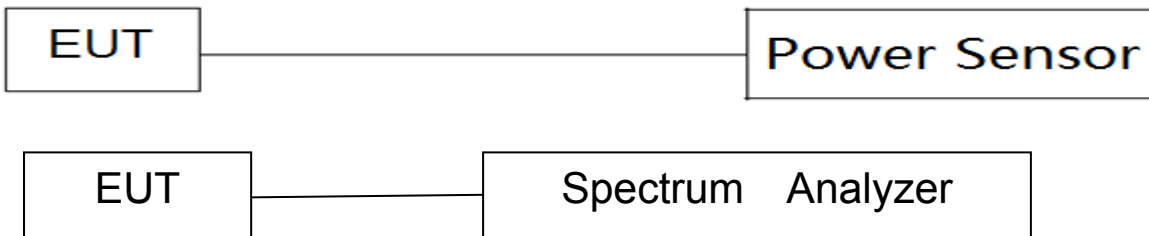

7.5 EUT OPERATION CONDITIONS

The EUT tested system was configured as the statements of 5 Unless otherwise a special operating condition is specified in the follows during the testing.



7.6 TEST RESULTS

Note:

1. For mobile and portable client devices in the 5.15-5.25 GHz band, the maximum conducted output power over the frequency band of operation shall not exceed the lesser of 0.25 W.
2. For mobile and portable client devices in the 5.25-5.35 GHz band, the maximum conducted output power over the frequency band of operation shall not exceed the lesser of 0.25 W.
3. For mobile and portable client devices in the 5.47-5.725 GHz band, the maximum conducted output power over the frequency band of operation shall not exceed the lesser of 0.25 W.
4. For the band 5.745-5.850 GHz, the maximum conducted output power over the frequency band of operation shall not exceed the lesser of 1 W.

Band I (5.15-5.25GHz)									
Test Channel	Frequency (MHz)	Ant_A AV Power (dBm)	Ant_B AV Power (dBm)	Ant_A Duty cycle factor(dB)	Ant_B Duty cycle factor(dB)	Ant_A AV Power (dBm)	Ant_B AV Power (dBm)	AV Power Total(dBm)	LIMIT (dBm)
802.11a									
36	5180	12.06	11.94	0.086	0.086	12.15	12.03	--	23.98
40	5200	12.11	12.08	0.086	0.086	12.20	12.17	--	23.98
48	5240	12.21	12.16	0.086	0.086	12.30	12.25	--	23.98
802.11n(HT20)									
36	5180	9.05	9.00	0.104	0.104	9.15	9.10	12.14	23.98
40	5200	9.12	8.98	0.104	0.104	9.22	9.08	12.16	23.98
48	5240	9.13	9.02	0.104	0.104	9.23	9.12	12.19	23.98
802.11n(HT40)									
38	5190	8.28	8.01	0.220	0.220	8.50	8.23	11.38	23.98
46	5230	8.38	8.05	0.220	0.220	8.60	8.27	11.45	23.98
802.11ac(VHT20)									
36	5180	9.07	8.92	0.090	0.090	9.16	9.01	12.10	23.98
40	5200	9.12	9.10	0.090	0.090	9.21	9.19	12.21	23.98
48	5240	9.19	8.92	0.090	0.090	9.28	9.01	12.16	23.98
802.11ac(VHT40)									
38	5190	8.35	8.07	0.204	0.204	8.55	8.27	11.43	23.98
46	5230	8.42	7.93	0.204	0.204	8.62	8.13	11.40	23.98
802.11ac(VHT80)									
42	5210	9.31	8.25	0.438	0.438	9.75	8.69	12.26	23.98



Band II(5.25-5.35GHz)									
Test Channel	Frequency (MHz)	Ant_A AV Power (dBm)	Ant_B AV Power (dBm)	Ant_A Duty cycle factor(dB)	Ant_B Duty cycle factor(dB)	AV Power (dBm)	AV Power B(dBm)	AV Power Total(dBm)	LIMIT (dBm)
802.11a									
52	5260	12.20	12.18	0.061	0.061	12.26	12.24	--	23.98
60	5300	12.35	12.32	0.061	0.061	12.41	12.38	--	23.98
64	5320	12.39	12.31	0.061	0.061	12.45	12.37	--	23.98
802.11n(HT20)									
52	5260	9.25	9.19	0.104	0.104	9.35	9.29	12.33	23.98
60	5300	9.29	9.26	0.104	0.104	9.39	9.36	12.39	23.98
64	5320	9.25	9.17	0.104	0.104	9.35	9.27	12.32	23.98
802.11n(HT40)									
54	5270	9.17	8.80	0.233	0.233	9.40	9.03	12.23	23.98
62	5310	8.62	8.25	0.233	0.233	8.85	8.48	11.68	23.98
802.11ac(VHT20)									
52	5260	9.42	9.21	0.104	0.104	9.52	9.31	12.43	23.98
60	5300	9.40	9.24	0.104	0.104	9.50	9.34	12.43	23.98
64	5320	9.30	9.27	0.104	0.104	9.40	9.37	12.40	23.98
802.11ac(VHT40)									
54	5270	9.34	9.26	0.230	0.230	9.57	9.49	12.54	23.98
62	5310	9.35	9.16	0.230	0.230	9.58	9.39	12.50	23.98
802.11ac(VHT80)									
58	5290	8.51	8.45	0.451	0.451	8.96	8.90	11.94	23.98

Band III(5.47-5.725GHz)									
Test Channel	Frequency (MHz)	Ant_A AV Power (dBm)	Ant_B AV Power (dBm)	Ant_A Duty cycle factor(dB)	Ant_B Duty cycle factor(dB)	AV Power (dBm)	AV Power B(dBm)	AV Power Total(dBm)	LIMIT (dBm)
802.11a									
100	5500	12.36	12.16	0.086	0.086	12.45	12.25	--	23.98
116	5580	12.50	12.30	0.086	0.086	12.59	12.39	--	23.98
140	5700	12.44	12.43	0.086	0.086	12.53	12.52	--	23.98
802.11n(HT20)									
100	5500	9.47	9.07	0.104	0.104	9.57	9.17	12.39	23.98
116	5580	9.46	9.08	0.104	0.104	9.56	9.18	12.39	23.98
140	5700	9.58	9.24	0.104	0.104	9.68	9.34	12.53	23.98
802.11n(HT40)									
102	5510	9.17	8.50	0.219	0.219	9.39	8.72	12.08	23.98
110	5550	9.37	8.61	0.219	0.219	9.59	8.83	12.24	23.98
134	5670	9.27	8.68	0.219	0.219	9.49	8.90	12.21	23.98
802.11ac(VHT20)									
100	5500	9.49	9.05	0.091	0.091	9.58	9.14	12.38	23.98
116	5580	9.57	9.05	0.091	0.091	9.66	9.14	12.42	23.98
140	5700	9.59	9.19	0.091	0.091	9.68	9.28	12.50	23.98
802.11ac(VHT40)									
102	5510	9.58	9.23	0.230	0.230	9.81	9.46	12.65	23.98
110	5550	9.59	9.21	0.230	0.230	9.82	9.44	12.64	23.98
134	5670	9.61	9.01	0.230	0.230	9.84	9.24	12.56	23.98
802.11ac(VHT80)									
106	5530	8.79	8.11	0.451	0.451	9.24	8.56	11.92	23.98
122	5610	8.70	8.22	0.451	0.451	9.15	8.67	11.93	23.98



Band IV (5.725-5.85GHz)									
Test Channel	Frequency (MHz)	Ant_A AV Power (dBm)	Ant_B_AV Power (dBm)	Ant_A Duty cycle factor(dB)	Ant_B Duty cycle factor(dB)	AV Power (dBm)	AV Power B(dBm)	AV Power Total(dBm)	LIMIT (dBm)
802.11a									
149	5745	9.39	9.24	0.086	0.086	9.48	9.33	--	30
157	5785	9.37	9.35	0.086	0.086	9.46	9.44	--	30
165	5825	9.25	9.21	0.086	0.086	9.34	9.30	--	30
802.11n(HT20)									
149	5745	5.56	5.38	0.104	0.104	5.66	5.48	8.586	30
157	5785	5.42	5.37	0.104	0.104	5.52	5.47	8.510	30
165	5825	5.36	5.25	0.104	0.104	5.46	5.35	8.420	30
802.11n(HT40)									
151	5755	5.20	4.79	0.233	0.233	5.43	5.02	8.243	30
159	5795	5.33	5.26	0.233	0.233	5.56	5.49	8.538	30
802.11ac(VHT20)									
149	5745	5.36	5.28	0.065	0.065	5.42	5.34	8.395	30
157	5785	5.68	5.41	0.065	0.065	5.74	5.47	8.622	30
165	5825	5.33	5.11	0.065	0.065	5.39	5.17	8.296	30
802.11ac(VHT40)									
151	5755	5.55	5.51	0.230	0.230	5.78	5.74	8.770	30
159	5795	5.34	5.20	0.230	0.230	5.57	5.43	8.511	30
802.11ac(VHT80)									
155	5775	5.73	5.00	0.451	0.451	6.18	5.45	8.842	30



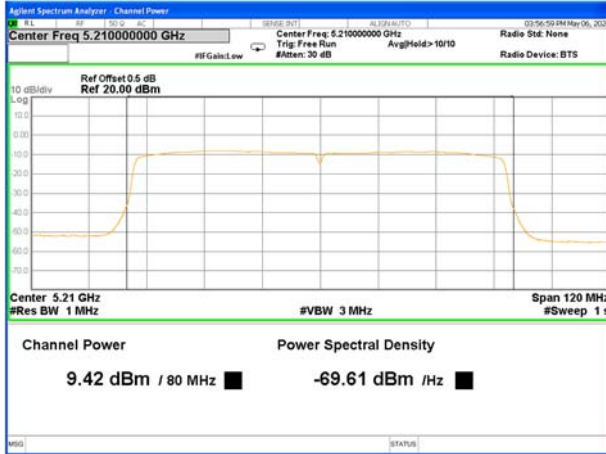

5210MHz_AV_Ant A

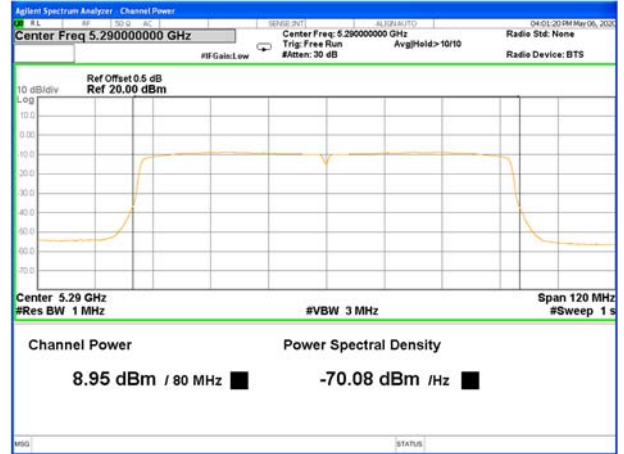

5290MHz_AV_Ant A

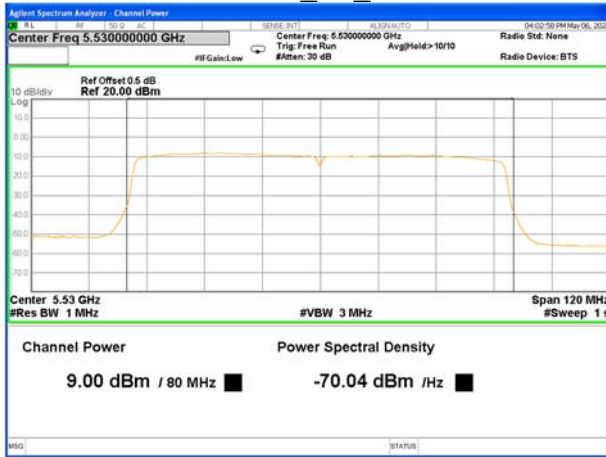

5530MHz_AV_Ant A

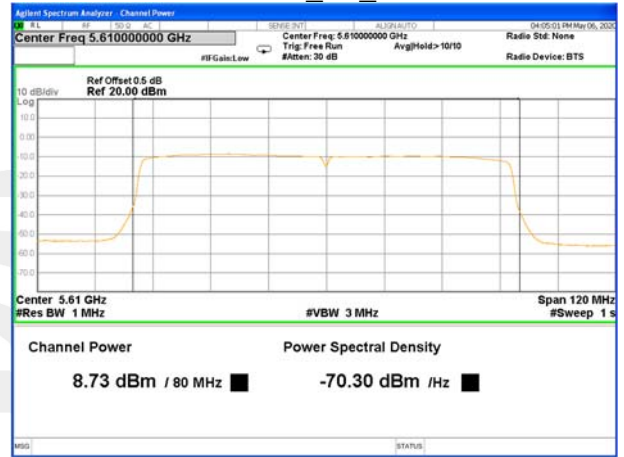

5610MHz_AV_Ant A

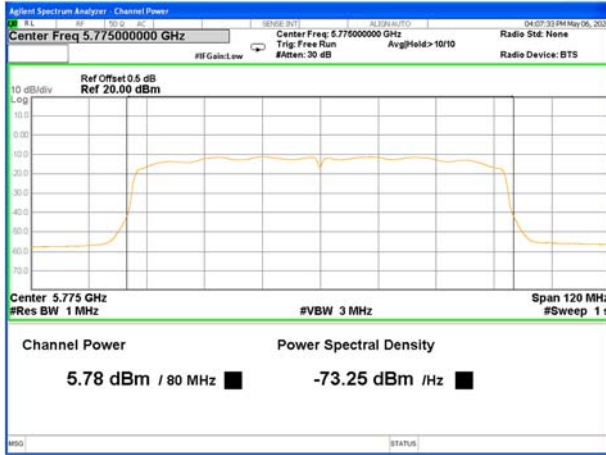

5775MHz_AV_Ant A

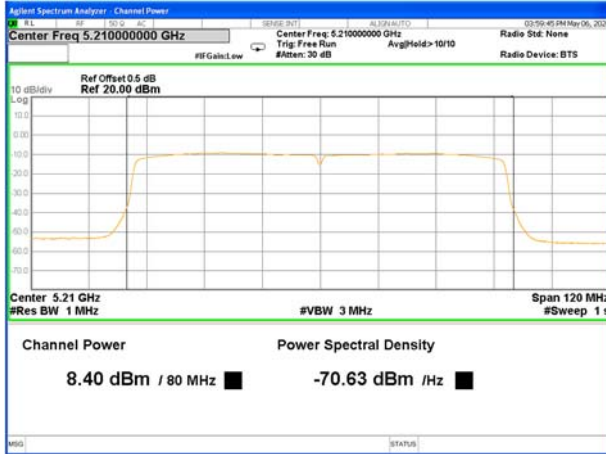

5210MHz_AV_Ant A

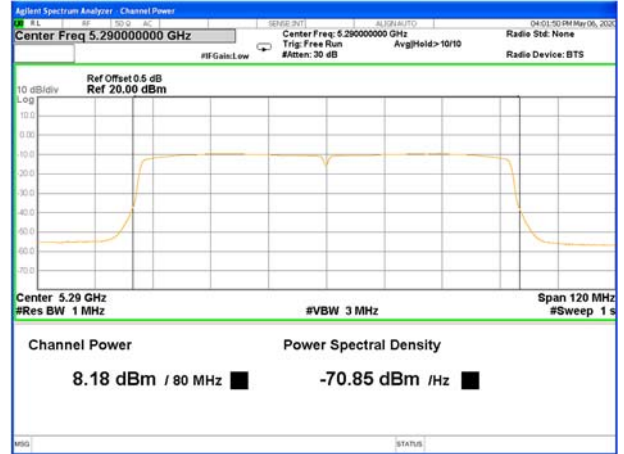

5290MHz_AV_Ant A

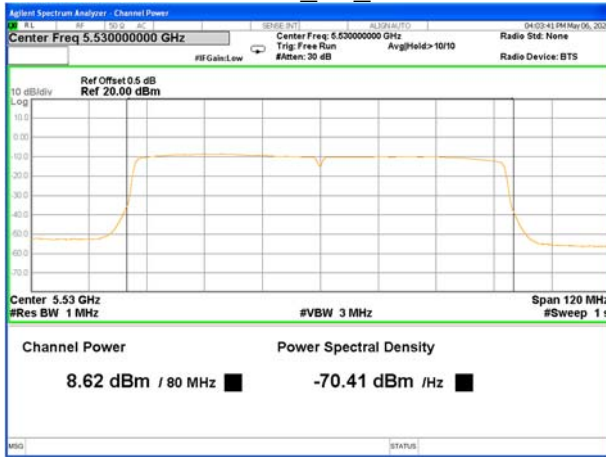

5530MHz_AV_Ant A

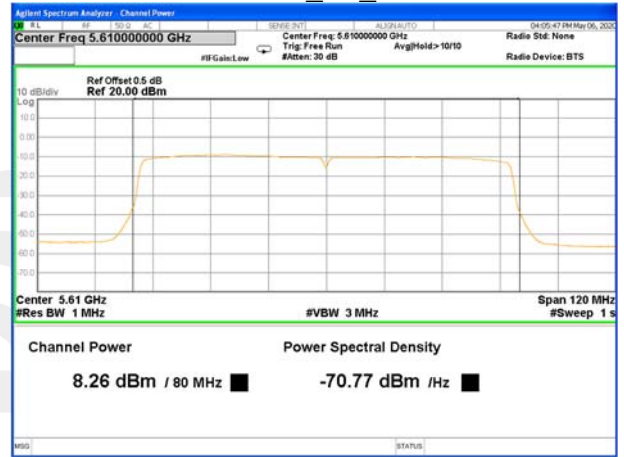

5610MHz_AV_Ant A

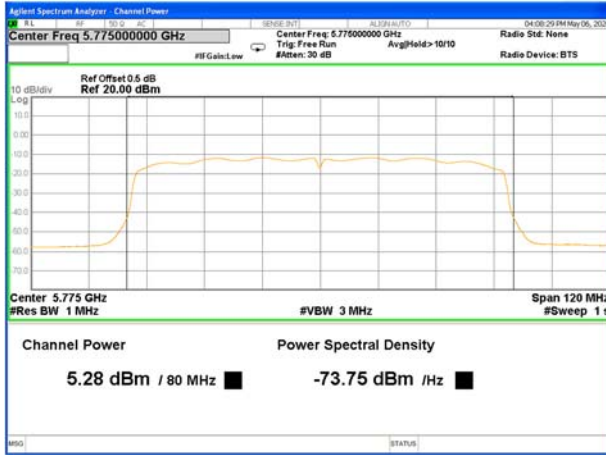

5775MHz_AV_Ant A



Duty cycle

5150-5250MHz				
Mode	Ton(ms)	Tp(ms)	Duty cycle(%)	Duty factor(dB)
a	1.408	1.436	98.05%	0.086
n20	1.324	1.356	97.64%	0.104
n40	0.654	0.688	95.06%	0.220
ac20	1.332	1.360	97.94%	0.090
ac40	0.664	0.696	95.40%	0.204
ac80	0.330	0.365	90.41%	0.438

5250-5350MHz				
Mode	Ton(ms)	Tp(ms)	Duty cycle(%)	Duty factor(dB)
a	1.416	1.436	98.61%	0.061
n20	1.320	1.352	97.63%	0.104
n40	0.652	0.688	94.77%	0.233
ac20	1.324	1.356	97.64%	0.104
ac40	0.662	0.698	94.84%	0.230
ac80	0.329	0.365	90.14%	0.451

5470-5725MHz				
Mode	Ton(ms)	Tp(ms)	Duty cycle(%)	Duty factor(dB)
a	1.408	1.436	98.05%	0.086
n20	1.316	1.348	97.63%	0.104
n40	0.656	0.690	95.07%	0.219
ac20	1.328	1.356	97.94%	0.091
ac40	0.662	0.698	94.84%	0.230
ac80	0.329	0.365	90.14%	0.451

5725-5850MHz				
Mode	Ton(ms)	Tp(ms)	Duty cycle(%)	Duty factor(dB)
a	1.408	1.436	98.05%	0.086
n20	1.316	1.348	97.63%	0.104
n40	0.654	0.690	94.78%	0.233
ac20	1.336	1.356	98.53%	0.065
ac40	0.662	0.698	94.84%	0.230
ac80	0.329	0.365	90.14%	0.451



Band 1-a20



Band 1-n20



Band 1-n40



Band 1-ac20



Band 1-ac40



Band 1-ac80



Band 2-a20



Band 2-n20



Band 2-n40



Band 2-ac20



Band 2-ac40



Band 2-ac80



Band 3-a20



Band 3-n20



Band 3-n40



Band 3-ac20



Band 3-ac40



Band 3-ac80



Band 4-a20



Band 4-n20



Band 4-n40



Band 4-ac20



Band 4-ac40



Band 4-ac80



8. Automatically Discontinue Transmission

8.1 LIMIT OF AUTOMATICALLY DISCONTINUE TRANSMISSION

The device shall automatically discontinue transmission in case of either absence of information to transmit or operational failure. These provisions are not intended to preclude the transmission of control or signaling information or the use of repetitive codes used by certain digital technologies to complete frame or burst intervals. Applicants shall include in their application for equipment authorization to describe how this requirement is met.

8.2 TEST RESULT OF AUTOMATICALLY DISCONTINUE TRANSMISSION

During no any information transmission, the EUT can automatically discontinue transmission and become standby mode for power saving. The EUT can detect the controlling signal of ACK message transmitting from remote device and verify whether it shall resend or discontinue transmission





9. ANTENNA REQUIREMENT

9.1 STANDARD REQUIREMENT

15.203 requirement: For intentional device, according to 15.203: an intentional radiator shall be designed to ensure that no antenna other than that furnished by the responsible party shall be used with the device.

9.2 EUT ANTENNA

The EUT antenna is PIFA Antenna Antenna. It comply with the standard requirement.





APPENDIX - PHOTOS OF TEST SETUP

Note: See test photos in setup photo document for the actual connections between Product and support equipment.

※※※※※END OF THE REPORT※※※※※

