

FCC TEST REPORT

according to

FCC Rules and Regulations Part 15 Subpart B & C

Applicant	AboCom Systems, Inc.
Address	1F No. 21, R&D Rd. II, SBIP Hsin-Chu 300, Taiwan, R.O.C.
Equipment	Multi-Function 802.11g Wireless Router
Model No.	ARM914
FCC ID	MQ4ARM914
Trade Name	AboCom

- The test result refers exclusively to the test presented test model / sample.
- Without written approval of *Exclusive Certification Corp.* the test report shall not be reproduced except in full.

Contents

1.	Report of Measurements and Examinations	4
1.1.	List of Measurements and Examinations	4
1.2.	Antenna Requirements	5
1.3.	Test of Conducted Emission.....	6
1.4.	Test of Radiated Emission	8
1.5.	6dB Bandwidth	9
1.6.	Maximum Peak Output Power.....	9
1.7.	Band Edges Measurement	10
1.8.	Power Spectral Density	10
1.9.	Restricted Bands of Operation	11
1.10.	Labeling Requirement	11
1.11.	RF Exposure	12
2.	Test Configuration of Equipment under Test	14
2.1.	Test Mode	14
2.2.	Description of Test System	14
2.3.	Connection Diagram of Test System.....	15
2.4.	Feature of Equipment under Test	15
2.5.	URL Content FilteringHistory of this test report	15
3.	General Information of Test.....	16
4.	Test Result and Data.....	17
4.1.	Antenna Requirement	17
4.2.	Test Result of Conducted Emission	18
4.3.	Test Result of Radiated Emission	31
4.4.	6dB Bandwidth Measurement Data	46
4.5.	Peak Output Power Measurement Data.....	50
4.6.	Band Edges Measurement Data	54
4.7.	Power Spectral Density Measurement Data	66
4.8.	Test Result of RF Exposure Evaluation	70
5.	List of Measuring Equipment Used	71
Appendix A. Photographs of EUT.....		A1 ~ A4

CERTIFICATE OF COMPLIANCE

according to

FCC Rules and Regulations Part 15 Subpart B & C

Applicant	AboCom Systems, Inc.
Address	1F No. 21, R&D Rd. II, SBIP Hsin-Chu 300, Taiwan, R.O.C.
Equipment	Multi-Function 802.11g Wireless Router
Model No.	ARM914
FCC ID	MQ4ARM914

I HEREBY CERTIFY THAT :

The measurements shown in this test report were made in accordance with the procedures given in **ANSI C63.4**. The equipment was **passed** the test performed according to **FCC Rules and Regulations Part 15 Subpart B & C (2002)**. The test was carried out on Apr. 01, 2004 at *Exclusive Certification Corp.*

Signature

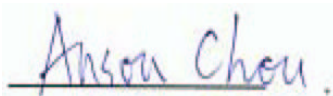

Anson Chou / Manager

1. Report of Measurements and Examinations

1.1. List of Measurements and Examinations

FCC Rule	Description of Test	Result
15.203	. Antenna Requirement	Pass
15.207	. Conducted Emission	Pass
15.209	. Radiated Emission	Pass
15.247(a)(2)	. 6dB Bandwidth	Pass
15.247(b)	. Maximum Peak Output Power	Pass
15.247(c)	. 100kHz Bandwidth of Frequency Band Edges	Pass
15.247(d)	. Power Spectral Density	Pass
1.1307 1.1310 2.1091 2.1093	. RF Exposure Compliance	Pass

Test by: Tony

1.2. Antenna Requirements

1.2.1. Standard Applicable

For intentional device, according to FCC 47 CFR Section 15.203, an intentional radiator shall be designed to ensure that no antenna other than that furnished by the responsible party shall be used with the device.

And according to FCC 47 CFR Section 15.247 (b), if transmitting antennas of directional gain greater than 6dBi are used, the power shall be reduced by the amount in dB that the directional gain of the antenna exceeds 6dBi.

1.3. Test of Conducted Emission

Conducted Emissions were measured from 150 kHz to 30 MHz with a bandwidth of 9 KHz on the 115 VAC power and return leads of the EUT according to the methods defined in ANSI C63.4-1992 Section 3.1. The EUT was placed on a nonmetallic stand in a shielded room 0.8 meters above the ground plane as shown in section 2.2. The interface cables and equipment positioning were varied within limits of reasonable applications to determine the position produced maximum conducted emissions.

1.3.1. Test Procedures

- a. The EUT was placed 0.4 meter from the conducting wall of the shielding room was kept at least 80 centimeters from any other grounded conducting surface.
- b. Connect EUT to the power mains through a line impedance stabilization network (LISN).
- c. All the support units are connecting to the other LISN.
- d. The LISN provides 50 ohm coupling impedance for the measuring instrument.
- e. The FCC states that a 50 ohm, 50 microhenry LISN should be used.
- f. Both sides of AC line were checked for maximum conducted interference.
- g. The frequency range from 150 kHz to 30 MHz was searched.
- h. Set the test-receiver system to Peak Detect Function and Specified Bandwidth with Maximum Hold Mode.

1.3.2. Typical Test Setup Layout of Conducted Emission

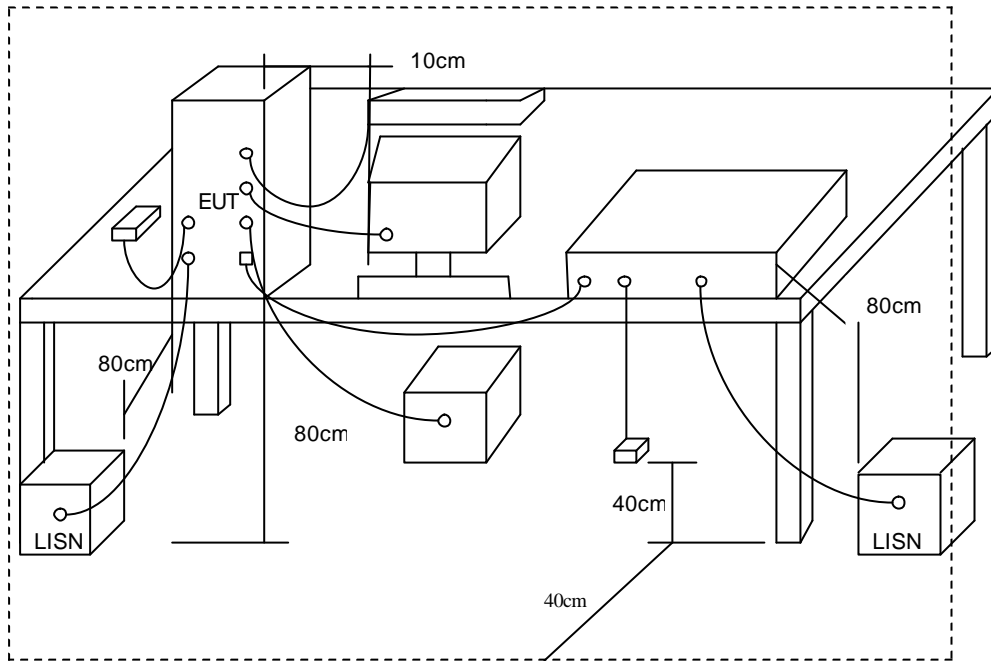

1.3.3. Conducted Emission Requirement

Except for A digital devices, for equipment that is designed to be connected to the public utility (AC) power line on any frequency voltage that is conducted back onto the AC power line on any frequency or frequencies within the band 150KHz to 30MHz shall not exceed the limits in the following table, as measured using a 50μH/50 ohms line impedance stabilization network (LISN). Compliance with the provisions of this paragraph shall be based on the measurement of the Radio frequency voltage between each power line and ground at the power terminal. The lower limit applies at the band edges.

Frequency (MHz)	Quasi Peak (dB μ V)	Average (dB μ V)
0.15 – 0.5	66-56*	56-46*
0.5 – 5.0	56	46
5.0 – 30.0	60	50

1.4. Test of Radiated Emission

Radiated emissions from 30 MHz to 25 GHz were measured according to the methods defines in ANSI C63.4-2001. The EUT was placed, 0.8 meter above the ground plane, as shown in section 5.6.3. The interface cables and equipment positions were varied within limits of reasonable applications to determine the positions producing maximum radiated emissions

1.4.1. Test Procedures

1. The EUT was placed on a rotatable table top 0.8 meter above ground.
2. The EUT was set 3 meters from the interference receiving antenna which was mounted on the top of a variable height antenna tower.
3. The table was rotated 360 degrees to determine the position of the highest radiation.
4. The antenna is a broadband antenna and its height is varied between one meter and four meters above ground to find the maximum value of the field strength both horizontal polarization and vertical polarization of the antenna are set to make the measurement.
5. For each suspected emission the EUT was arranged to its worst case and then tune the antenna tower (from 1 M to 4 M) and turn table (from 0 degree to 360 degrees) to find the maximum reading.
6. Set the test-receiver system to Peak or CISPR quasi-peak Detect Function and specified bandwidth with Maximum Hold Mode.
7. If the emission level of the EUT in peak mode was 3 dB lower than the limit specified, then testing will be stopped and peak values of EUT will be reported, otherwise, the emissions which do not have 3 dB margin will be repeated one by one using the quasi-peak method and reported.
8. For testing above 1GHz, the emission level of the EUT in peak mode was 20dB lower than average limit (that means the emission level in peak mode also complies with the limit in average mode), then testing will be stopped and peak values of EUT will be reported, otherwise, the emissions will be measured in average mode again and reported.

1.4.2. Typical Test Setup Layout of Radiated Emission

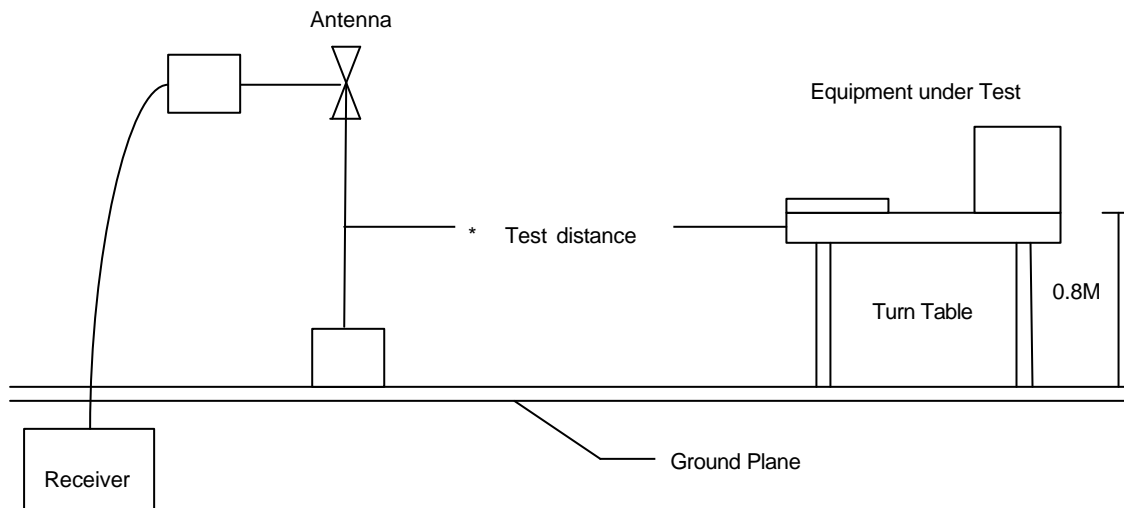

1.5. 6dB Bandwidth

1.5.1. Test Procedure :

1. The transmitter output was connected to the spectrum analyzer.
2. Set RBW of spectrum analyzer to 100 KHz and VBW to 100 KHz.
3. The 6 dB bandwidth is defined as the total spectrum the power of which is higher than peak power minus 6 dB.

1.5.2. Test Setup Layout :

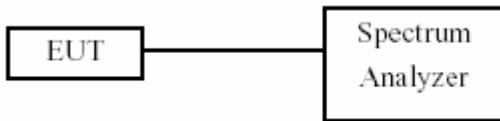

1.6. Maximum Peak Output Power

1.6.1. Test Procedure :

The antenna port (RF output) of the EUT was connected to the input (RF input) of a power meter. Power was read directly from the meter and cable loss connection was added to the reading to obtain power at the EUT antenna terminal. The EUT Output Power was set to maximum to produce the worse case test result.

1.6.2. Test Setup Layout :

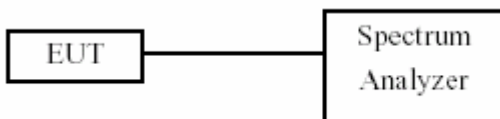

1.7. Band Edges Measurement

1.7.1. Test Procedure :

1. The transmitter output was connected to the spectrum analyzer via a low lose cable.
2. Set both RBW and VBW of spectrum analyzer to 100 KHz with convenient frequency span including 100 KHz bandwidth from band edge.
3. The band edges was measured and recorded.

1.8. Power Spectral Density

1.8.1. Test Procedure :

1. The transmitter output was connected to spectrum analyzer.
2. The spectrum analyzer' s resolution bandwidth were set at 3KHz RBW and 30KHz VBW as that of the fundamental frequency. Set the sweep time=span/3KHz.
3. The power spectral density was measured and recorded.
4. The Sweep time is allowed to be longer than span/3KHz for a full response of the mixer in the spectrum analyzer.

1.8.2. Test Setup Layout :

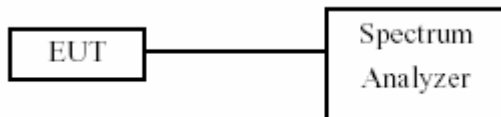

1.9. Restricted Bands of Operation

Only spurious emissions are permitted in any of the frequency bands listed below:

MHz	MHz	MHz	GHz
0.09000 – 0.11000	16.42000 – 16.42300	399.9 – 410.0	4.500 – 5.250
0.49500 – 0.505**	16.69475 – 16.69525	608.0 – 614.0	5.350 – 5.460
2.17350 – 2.19050	16.80425 – 16.80475	960.0 – 1240.0	7.250 – 7.750
4.12500 – 4.12800	25.50000 – 25.67000	1300.0 – 1427.0	8.025 – 8.500
4.17725 – 4.17775	37.50000 – 38.25000	1435.0 – 1626.5	9.000 – 9.200
4.20725 – 4.20775	73.00000 – 74.60000	1645.5 – 1646.5	9.300 – 9.500
6.21500 – 6.21800	74.80000 – 75.20000	1660.0 – 1710.0	10.600 – 12.700
6.26775 – 6.26825	108.00000 – 121.94000	1718.8 – 1722.2	13.250 – 13.400
6.31175 – 6.31225	123.00000 – 138.00000	2200.0 – 2300.0	14.470 – 14.500
8.29100 – 8.29400	149.90000 – 150.05000	2310.0 – 2390.0	15.350 – 16.200
8.36200 – 8.36600	156.52475 – 156.52525	2483.5 – 2500.0	17.700 – 21.400
8.37625 – 8.38675	156.70000 – 156.90000	2655.0 – 2900.0	22.010 – 23.120
8.41425 – 8.41475	162.01250 – 167.17000	3260.0 – 3267.0	23.600 – 24.000
12.29000 – 12.29300	167.72000 – 173.20000	3332.0 – 3339.0	31.200 – 31.800
12.51975 – 12.52025	240.00000 – 285.00000	3345.8 – 3358.0	36.430 – 36.500
12.57675 – 12.57725	322.00000 – 335.40000	3600.0 – 4400.0	Above 38.6
13.36000 – 13.41000			

** : Until February 1, 1999, this restricted band shall be 0.490-0.510 MHz

1.10. Labeling Requirement

The device shall bear the following statement in a conspicuous location on the device:

This device complies with part 15 of the FCC Rules. Operation is subject to the following two conditions: (1) This device may not cause harmful interference, and (2) this device must accept any interference received, including interference that may cause undesired operation.

1.11. RF Exposure

FCC Rules and Regulations Part 1.1307, 1.1310, 2.1091, 2.1093:
RF Exposure Compliance

1.11.1. Limit For Maximum Permissible Exposure (MPE)

(A) Limits for Occupational / Controlled Exposure

Frequency Range (MHz)	Electric Field Strength (E) (V/m)	Magnetic Field Strength (H) (A/m)	Power Density (S) (mW/ cm ²)	Averaging Time E ² , H ² or S (minutes)
0.3-3.0	614	1.63	(100)*	6
3.0-30	1842/f	4.89/f	(900/f)*	6
30-300	61.4	0.163	1.0	6
300-1500			F/300	6
1500-100,000			5	6

(B) Limits for General Population / Uncontrolled Exposure

Frequency Range (MHz)	Electric Field Strength (E) (V/m)	Magnetic Field Strength (H) (A/m)	Power Density (S) (mW/cm ²)	Averaging Time E ² , H ² or S (minutes)
0.3-1.34	614	1.63	(100)*	30
1.34-30	824/f	2.19/f	(180/f)*	30
30-300	27.5	0.073	0.2	30
300-1500			F/1500	30
1500-100,000			1.0	30

F=frequency in MHz

*Plane-wave equivalent power density

1.11.2. MPE Calculations

$$E \text{ (V/m)} = \frac{\sqrt{30 \cdot P \cdot G}}{d} \quad \text{Power Density: } Pd \text{ (mW/cm}^2\text{)} = \frac{E^2}{3770}$$

E = Electric field (V/m)

P = Peak output power (W)

G = Antenna numeric gain (numeric)

d = Separation distance (m)

Because the EUT is belong to General Population/ Uncontrolled Exposure. So the Limit of Power Density is 10 W/m². We can change the formula to:

$$d = \sqrt{\frac{30 \cdot P \cdot G}{3770}}$$

1.11.3. FCC Radiation Exposure Statement

This equipment complies with FCC radiation exposure limits set forth for an uncontrolled environment. In order to avoid the possibility of exceeding the FCC radio frequency exposure limits, human proximity to the antenna shall not be less than 20cm (8 inches) during normal operation. Proposed RF exposure safety information to include in User' s Manual.

2. Test Configuration of Equipment under Test

2.1. Test Mode

The following test mode was performed for conduction test:

- 802.11b (CH HI) • 802.11b (CH MID) • 802.11b (CH LO)
- 802.11g (CH HI) • 802.11g (CH MID) • 802.11g (CH LO)

The following test mode was performed for radiation test:

- Receiving / Transmitting

2.2. Description of Test System

Device	Manufacturer	Model No.	Description
PC (Remote site)	IBM	IGV	Power Cord, Unshielding, 1.8m
Monitor (Remote site)	SlimAGE	510A	Power Cord, Unshielding, 1.8m Data Cable, Shielding, 1.35m
Keyboard (Remote site)	IBM	KB-0225	Data Cable, Shielding, 1.85m
Mouse (Remote site)	IBM	MO28VO	Data Cable, Shielding, 1.85m
Notebook(Remote site)	TOSHIBA	Satellite 1110	Power Cord, Unshielding, 1.8m

Use Cable:

Cable	Description
RJ-45*3	Unshielding, 1.8m
RJ-45*2	Unshielding, 10m

2.3. Connection Diagram of Test System

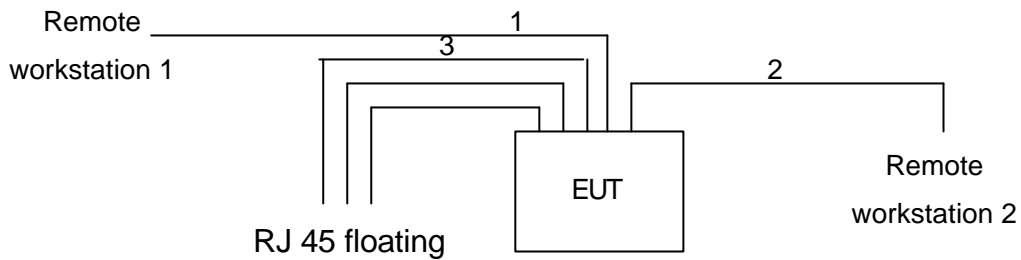

1. The TP cable is connected from remote workstation1 to the EUT.
2. The TP cable is connected from remote workstation2 to the EUT.
3. These cables are floating.

2.4. Feature of Equipment under Test

- Data rate up to 54 Mbps
- Backwards compatible
- 128-bit WEP encryption
- 1 port 10/100 Mbps N-Way WAN
- 4 ports 10/100Mbps N-Way LAN
- Web-Based management
- Remote management
- Supports PPPoE
- Support VPN
- Natural firewall (NAT)
- Auto detects & configures ISP
- Exposed Host (DMZ)
- MAC Address authentication

2.5. URL Content FilteringHistory of this test report

ORIGINAL.

3. General Information of Test

Test Site:	Exclusive Certification Corp. 4F-2, No. 28, Lane 78, Xing-Ai Rd. Nei-hu, Taipei City 114 Taiwan R.O.C.
Test Site Location (OATS1-SD):	No.68-1, Shihbachongsi, shihding Township, Taipei County 223, Taiwan, R.O.C.
Test Voltage:	AC 110V/ 60Hz
Test in Compliance with:	ANSI C63.4-1992 FCC Part 15 Subpart C
Frequency Range Investigated:	Conducted: from 150kHz to 30 MHz Radiation: from 30 MHz to 24620MHz
Test Distance:	The test distance of radiated emission from antenna to EUT is 3 M.

4. Test Result and Data

4.1. Antenna Requirement

4.1.1. Antenna Construction and Directional Gain

Antenna type: SMA antenna; the maximum antenna gain: +2.0 dBi.

4.2. Test Result of Conducted Emission

4.2.1. Test Mode 1: 802.11b (CH HI)

- Relative Humidity: 58 %
- Temperature: 27°C
- Test Date: Mar. 11, 2004

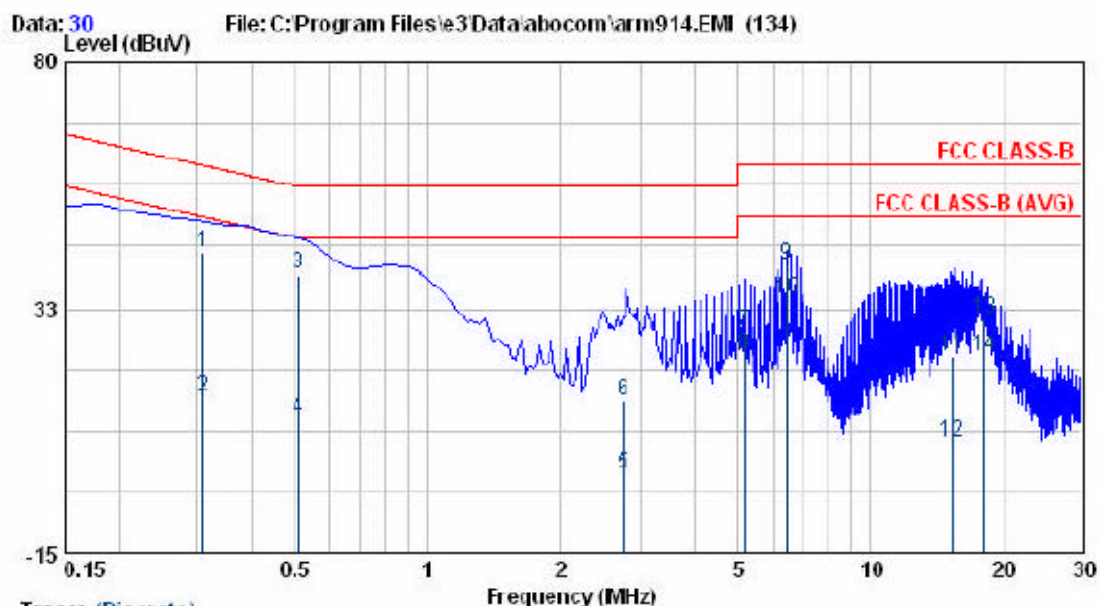

Condition:
 out : ARM914
 power : 110V 60Hz
 memo : RF Utility
 : 802.11b - CH HI

	Freq	Read		Level	Limit	Over	
	MHz	Level	Factor	dBuV	Line	Limit	Pol/Phase
		dBuV	dB	dBuV	dBuV	dB	
1	0.309	42.68	0.34	43.02	60.01	-16.99	NEUTRAL
2	0.309	15.07	0.34	15.41	50.01	-34.60	NEUTRAL
3	0.508	38.61	0.37	38.98	56.00	-17.02	NEUTRAL
4	0.508	10.56	0.37	10.93	46.00	-35.07	NEUTRAL
5	2.753	0.00	0.46	0.46	56.00	-55.54	NEUTRAL
6	2.753	14.01	0.46	14.47	46.00	-31.53	NEUTRAL
7	5.163	27.81	0.49	28.30	60.00	-31.70	NEUTRAL
8	5.163	23.14	0.49	23.63	50.00	-26.37	NEUTRAL
9	6.464	40.01	0.50	40.51	60.00	-19.49	NEUTRAL
10	6.464	33.77	0.50	34.27	50.00	-15.73	NEUTRAL
11	15.326	22.79	0.55	23.34	60.00	-36.66	NEUTRAL
12	15.326	5.97	0.55	6.52	50.00	-43.48	NEUTRAL
13	18.183	29.95	0.57	30.52	60.00	-29.48	NEUTRAL
14	18.183	22.76	0.57	23.33	50.00	-26.67	NEUTRAL

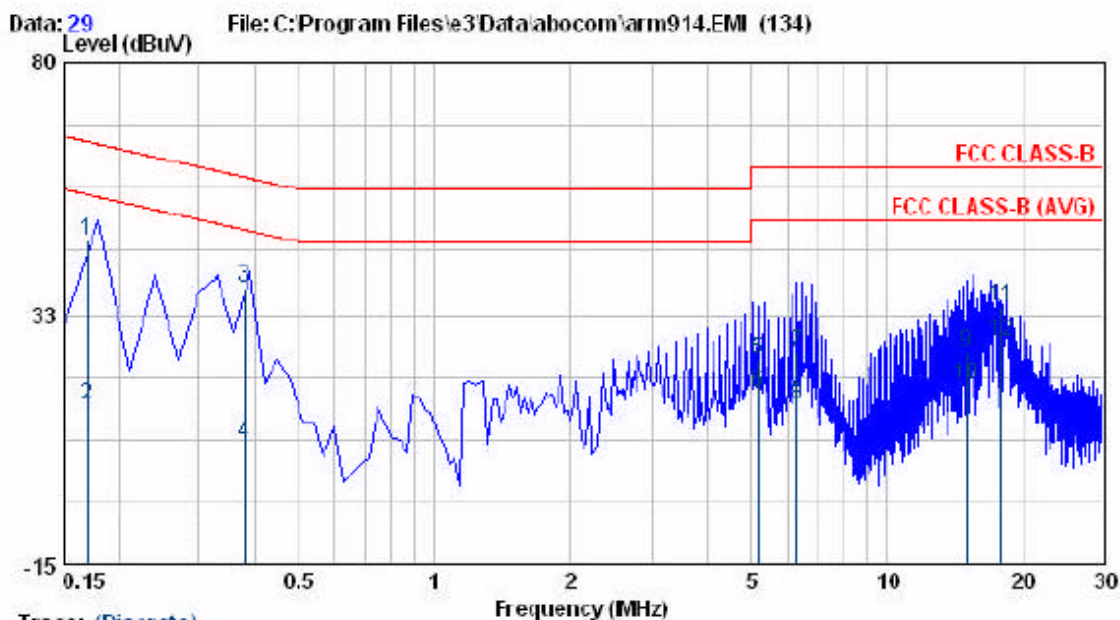

Condition:
 eut : ARM914
 power : 110V 60Hz
 memo : RF Utility
 : 802.11b - CK II

	Read			Limit	Over	
	Freq	Level	Factor	Remark	Level	Line
	MHz	dBuV	dB		dBuV	dBuV
1	0.169	45.93	0.31	QP	46.24	65.01 -18.78
2	0.169	15.01	0.31	AVERAGE	15.32	55.01 -39.70
3	0.377	37.07	0.36	QP	37.43	58.34 -20.92
4	0.377	7.72	0.36	AVERAGE	8.08	48.34 -40.27
5	5.161	23.36	0.49	QP	23.85	60.00 -36.15
6	5.161	17.24	0.49	AVERAGE	17.73	50.00 -32.27
7	6.328	25.03	0.50	QP	25.53	60.00 -34.47
8	6.328	14.82	0.50	AVERAGE	15.32	50.00 -34.68
9	15.007	24.86	0.55	QP	25.41	60.00 -34.59
10	15.007	18.39	0.55	AVERAGE	18.94	50.00 -31.06
11	17.940	33.44	0.56	QP	34.00	60.00 -26.00
12	17.940	26.86	0.56	AVERAGE	27.42	50.00 -22.58

4.2.2. Test Mode 2: 802.11b (CH MID)

- Relative Humidity: 58 %
- Temperature: 27°C
- Test Date: Mar. 11, 2004

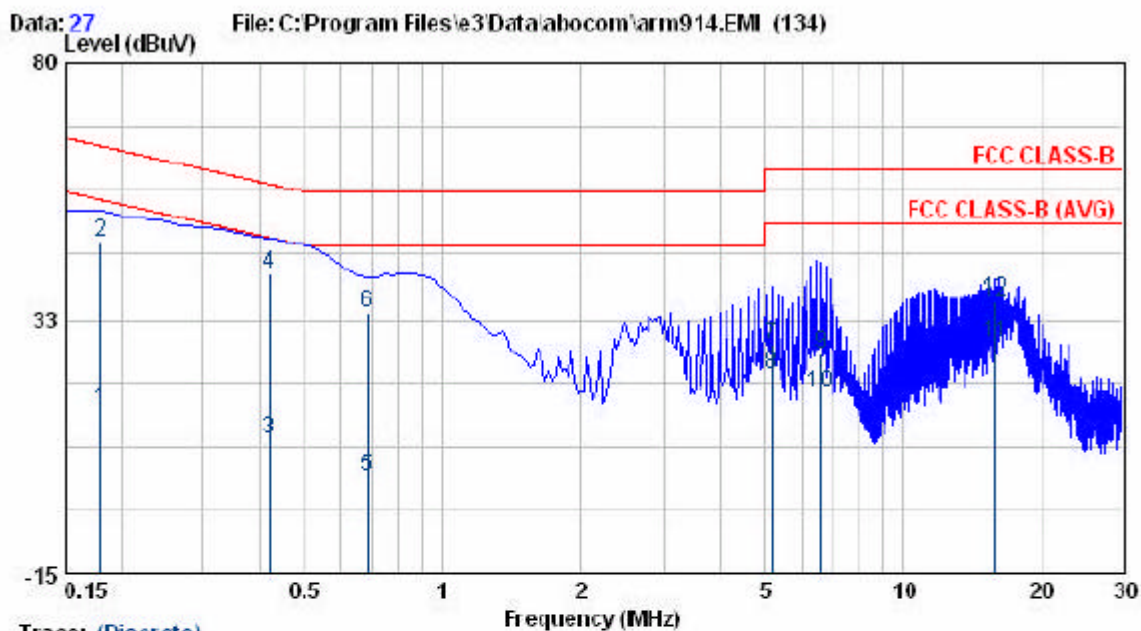

Trace: (Discrete)

Condition:
 out : ARM914
 power : 110V 60Hz
 memo : RF Utility
 : 802.11b - CH MID

	Read Freq	Read Level	Factor	Remark	Limit Level	Over Line	Over Limit	Pol/Phase
	MHz	dBuV	dB		dBuV	dBuV	dB	
1	0.180	15.17	0.31	AVERAGE	15.48	54.50	-39.02	NEUTRAL
2	0.180	46.19	0.31	QP	46.50	64.50	-18.00	NEUTRAL
3	0.419	9.80	0.36	AVERAGE	10.16	47.47	-37.31	NEUTRAL
4	0.419	40.45	0.36	QP	40.81	57.47	-16.66	NEUTRAL
5	0.687	2.54	0.39	AVERAGE	2.93	46.00	-43.07	NEUTRAL
6	0.687	33.24	0.39	QP	33.63	56.00	-22.37	NEUTRAL
7	5.162	27.20	0.49	QP	27.69	60.00	-32.31	NEUTRAL
8	5.162	21.78	0.49	AVERAGE	22.27	50.00	-27.73	NEUTRAL
9	6.629	25.53	0.50	QP	26.03	60.00	-33.97	NEUTRAL
10	6.629	18.42	0.50	AVERAGE	18.92	50.00	-31.08	NEUTRAL
11	15.880	27.53	0.56	AVERAGE	28.09	50.00	-21.91	NEUTRAL
12	15.880	35.19	0.56	QP	35.75	60.00	-24.25	NEUTRAL

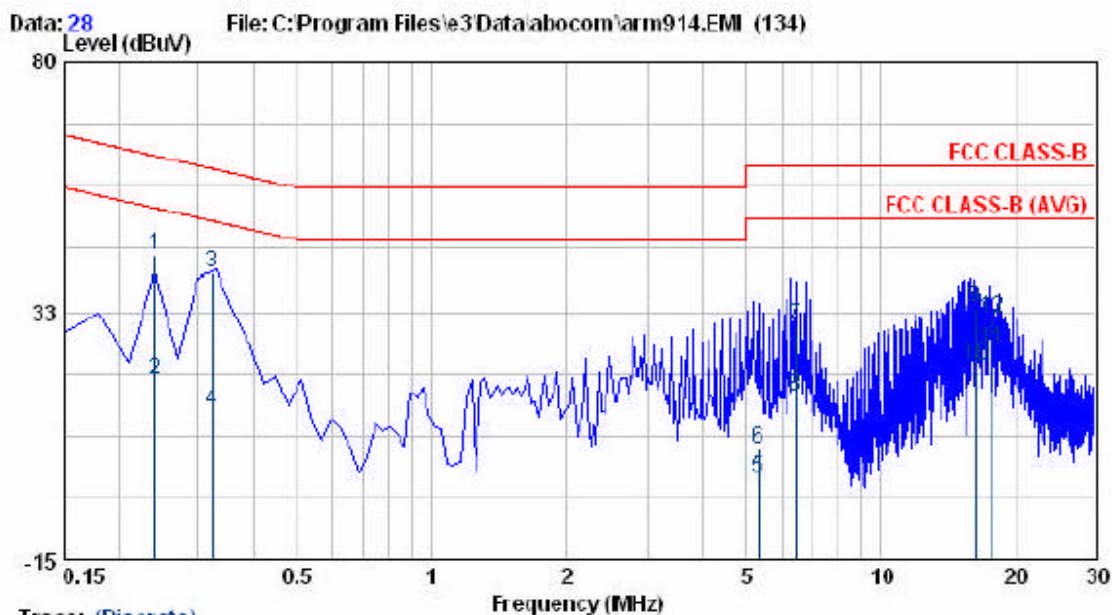

Trace: (Discrete)

Condition:
 eut : ARM914
 power : 110V 60Hz
 memo : RF Utility
 : 802.11b - CH MID

	Read Freq	Read Level	Factor	Remark	Level	Limit Line	Over Limit	Pol/Phase
	MHz	dBuV	dB		dBuV	dBuV	dB	
1	0.240	42.67	0.33	QP	43.00	62.11	-19.11	LINE
2	0.240	19.18	0.33	AVERAGE	19.51	52.11	-32.60	LINE
3	0.323	39.27	0.35	QP	39.62	59.64	-20.02	LINE
4	0.323	13.05	0.35	AVERAGE	13.40	49.64	-36.24	LINE
5	5.311	0.00	0.49	QP	0.49	60.00	-59.51	LINE
6	5.311	5.88	0.49	AVERAGE	6.37	50.00	-43.63	LINE
7	6.474	29.30	0.50	QP	29.80	60.00	-30.20	LINE
8	6.474	15.89	0.50	AVERAGE	16.39	50.00	-33.61	LINE
9	16.322	32.78	0.56	QP	33.34	60.00	-26.66	LINE
10	16.322	21.68	0.56	AVERAGE	22.24	50.00	-27.76	LINE
11	17.852	24.78	0.56	AVERAGE	25.34	50.00	-24.66	LINE
12	17.852	30.61	0.56	QP	31.17	60.00	-28.83	LINE

4.2.3. Test Mode 3: 802.11b (CH LO)

- Relative Humidity: 58 %
- Temperature: 27°C
- Test Date: Mar. 11, 2004

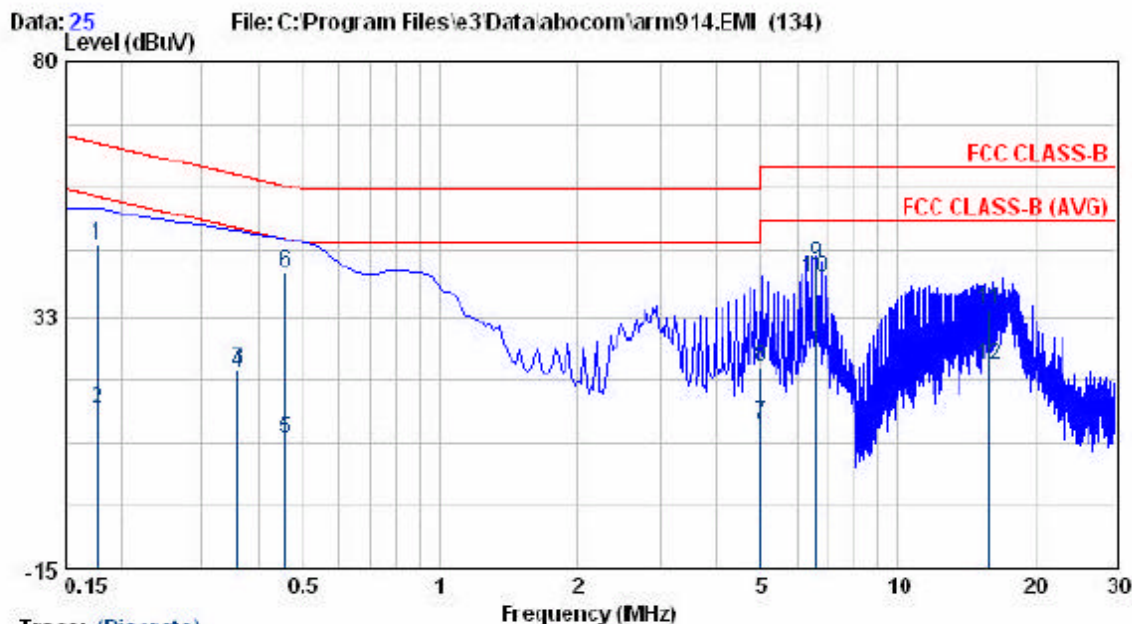

Trace: (Discrete)

Condition:

cut : ARM914
 power : 110V 60Hz
 memo : RF Utility
 : 802.11b - CH LO

	Freq	Read Level	Factor	Remark	Level	Limit Line	Over Limit	Pol/Phase
	MHz	dBuV	dB		dBuV	dBuV	dB	
1	0.177	45.40	0.31	QP	45.71	64.63	-18.92	NEUTRAL
2	0.177	14.46	0.31	AVERAGE	14.77	54.63	-39.86	NEUTRAL
3	0.358	22.25	0.35	QP	22.60	58.78	-36.18	NEUTRAL
4	0.358	21.46	0.35	AVERAGE	21.81	48.78	-26.97	NEUTRAL
5	0.456	9.05	0.37	AVERAGE	9.42	46.76	-37.35	NEUTRAL
6	0.456	39.91	0.37	QP	40.28	56.76	-16.49	NEUTRAL
7	5.008	11.67	0.48	AVERAGE	12.15	50.00	-37.85	NEUTRAL
8	5.008	22.33	0.48	QP	22.81	60.00	-37.19	NEUTRAL
9	6.618	41.32	0.50	QP	41.82	60.00	-18.18	NEUTRAL
10	6.618	38.88	0.50	AVERAGE	39.38	50.00	-10.62	NEUTRAL
11	15.880	33.23	0.56	QP	33.79	60.00	-26.21	NEUTRAL
12	15.880	22.86	0.56	AVERAGE	23.42	50.00	-26.58	NEUTRAL

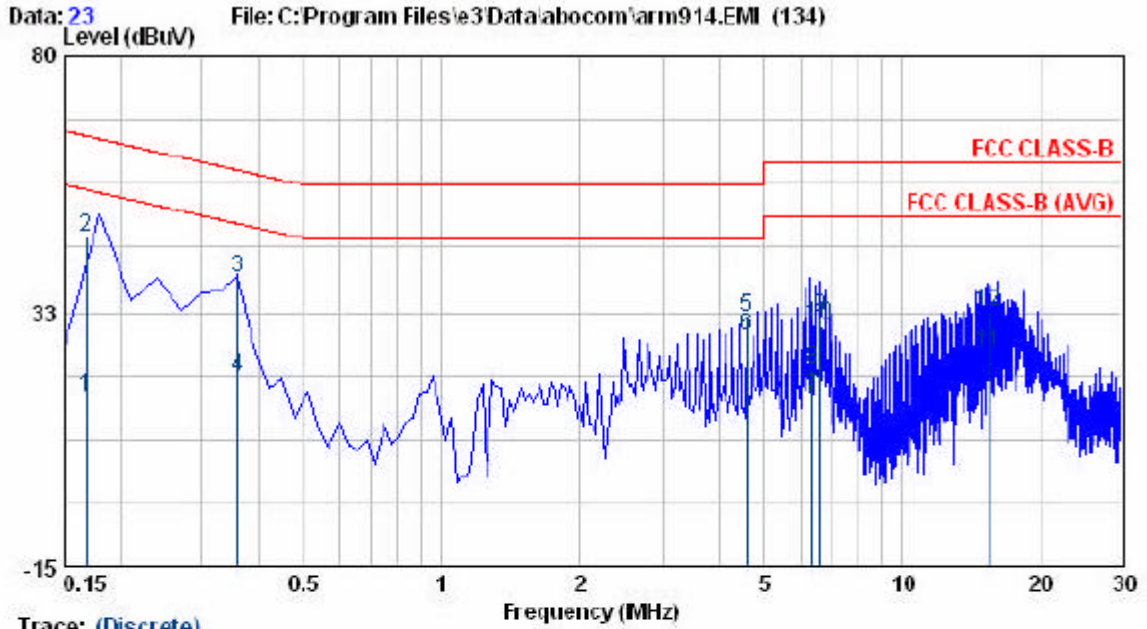

Condition:
 eut : ARM914
 power : 110V 60Hz
 memo : RF Utility
 : 802.11b - CH 10

	Freq	Read Level	Factor	Remark	Level	Limit Line	Over Limit	Pol/Phase
	MHz	dBuV	dB		dBuV	dBuV	dB	
1	0.168	16.24	0.31	AVERAGE	16.55	55.07	-38.53	LINE
2	0.168	45.97	0.31	QP	46.28	65.07	-18.80	LINE
3	0.358	38.13	0.35	QP	38.48	58.78	-20.30	LINE
4	0.358	20.25	0.35	AVERAGE	20.60	48.78	-28.18	LINE
5	4.568	31.16	0.48	QP	31.64	56.00	-24.36	LINE
6	4.568	27.72	0.48	Average	28.20	46.00	-17.80	LINE
7	6.384	16.03	0.50	AVERAGE	16.53	50.00	-33.47	LINE
8	6.384	21.44	0.50	QP	21.94	60.00	-38.06	LINE
9	6.624	31.23	0.50	QP	31.73	60.00	-28.27	LINE
10	6.624	29.70	0.50	AVERAGE	30.20	50.00	-19.80	LINE
11	15.461	24.32	0.55	AVERAGE	24.87	50.00	-25.13	LINE
12	15.461	32.06	0.55	QP	32.61	60.00	-27.39	LINE

4.2.4. Test Mode 4: 802.11g (CH HI)

- Relative Humidity: 58 %
- Temperature: 27°C
- Test Date: Mar. 11, 2004

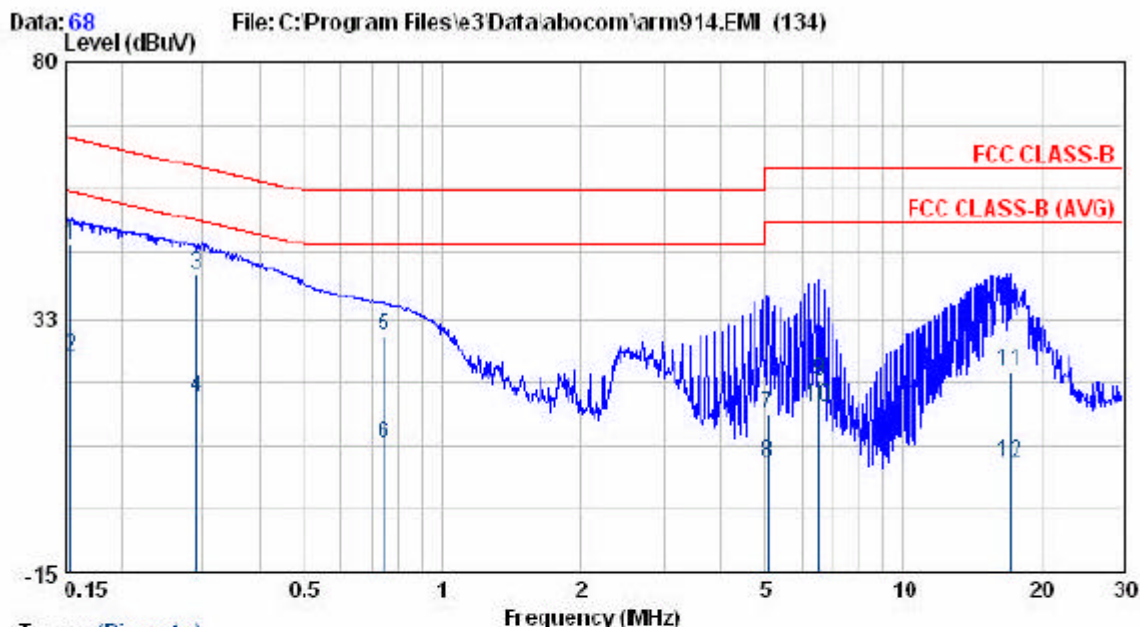

Condition:
 eut : ARM914
 power : 110V 60Hz
 memo : RF Utility
 : 802.11g - CH HI

	Read			Limit	Over		
	Freq	Level	Factor	Remark	Level	Line	Limit
	MHz	dBuV	dB		dBuV	dBuV	dB
1	0.154	45.57	0.30	QP	45.87	65.77	-19.89
2	0.154	25.17	0.30	AVERAGE	25.47	55.77	-30.29
3	0.289	39.96	0.34	QP	40.30	60.56	-20.26
4	0.289	17.36	0.34	AVERAGE	17.70	50.56	-32.86
5	0.743	28.63	0.40	QP	29.03	56.00	-26.97
6	0.743	8.60	0.40	AVERAGE	9.00	46.00	-37.00
7	5.081	14.00	0.49	QP	14.49	60.00	-45.51
8	5.081	5.09	0.49	AVERAGE	5.58	50.00	-44.42
9	6.564	20.33	0.50	QP	20.83	60.00	-39.17
10	6.564	15.42	0.50	AVERAGE	15.92	50.00	-34.08
11	17.107	22.05	0.56	QP	22.61	60.00	-37.39
12	17.107	4.99	0.56	AVERAGE	5.55	50.00	-44.45

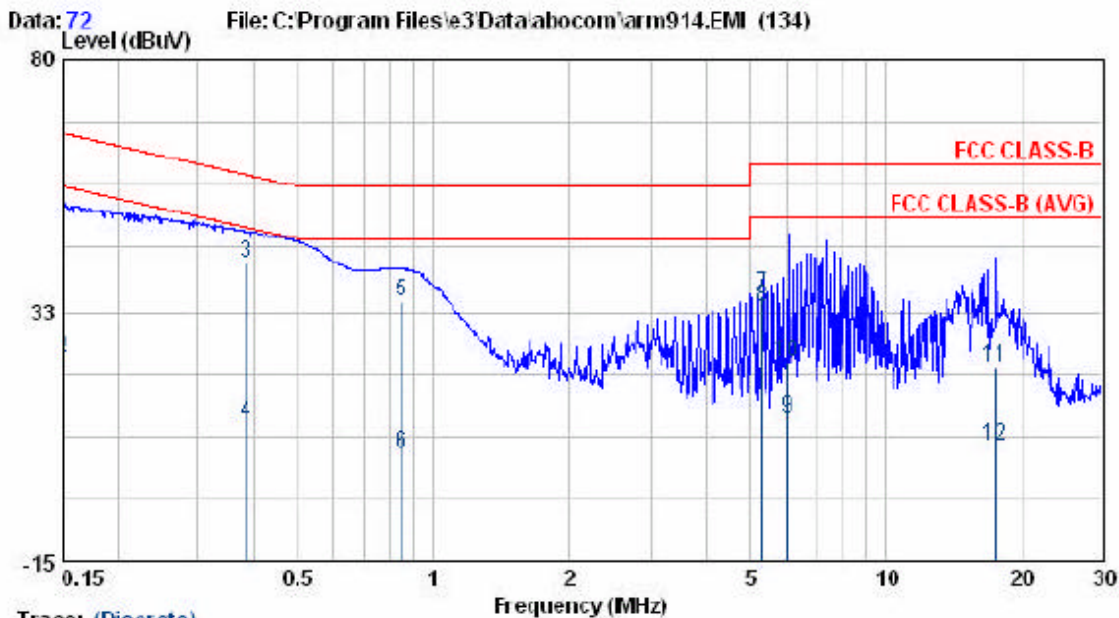

Condition:
 out : ARM914
 power : 110V 60Hz
 memo : RF Utility
 : 802.11g - CK II

	Read			Limit	Over			
	Freq	Level	Factor	Remark	Level	Line	Limit	Pol/Phase
	MHz	dBuV	dB		dBuV	dBuV	dB	
1	0.150	47.62	0.30	QP	47.92	65.99	-18.07	LINE
2	0.150	23.39	0.30	AVERAGE	23.69	55.99	-32.30	LINE
3	0.384	41.09	0.36	QP	41.45	58.20	-16.75	LINE
4	0.384	11.26	0.36	AVERAGE	11.62	48.20	-36.58	LINE
5	0.846	34.03	0.40	QP	34.43	56.00	-21.57	LINE
6	0.846	5.22	0.40	AVERAGE	5.62	46.00	-40.38	LINE
7	5.296	35.07	0.49	QP	35.56	60.00	-24.44	LINE
8	5.296	32.91	0.49	AVERAGE	33.40	50.00	-16.60	LINE
9	6.039	11.75	0.49	AVERAGE	12.24	50.00	-37.76	LINE
10	6.039	22.46	0.49	QP	22.95	60.00	-37.05	LINE
11	17.478	21.35	0.56	QP	21.91	60.00	-38.09	LINE
12	17.478	6.27	0.56	AVERAGE	6.83	50.00	-43.17	LINE