



EMI TEST REPORT

Test Report No. 14289102H-B

Customer	Mitsubishi Electric Corporation Himeji works
Description of EUT	Smart Keyless System (Smart Unit)
Model Number of EUT	SKE8AD-03
FCC ID	WAZSKE8AD03
Test Regulation	FCC Part 15 Subpart B
Test Result	Complied (Refer to SECTION 3)
Issue Date	June 21, 2022
Remarks	-

Representative Test Engineer

Ken Fujita
Engineer

Approved By

Tsubasa Takayama
Leader



CERTIFICATE 5107.02

- The testing in which "Non-accreditation" is displayed is outside the accreditation scopes in UL Japan, Inc.
 There is no testing item of "Non-accreditation".

Report Cover Page - Form-ULID-003532 (DCS:13-EM-F0429) Issue# 20.0

ANNOUNCEMENT

- This test report shall not be reproduced in full or partial, without the written approval of UL Japan, Inc.
- The results in this report apply only to the sample tested.
- This sample tested is in compliance with the limits of the above regulation.
- The test results in this test report are traceable to the national or international standards.
- This test report must not be used by the customer to claim product certification, approval, or endorsement by the A2LA accreditation body.
- This test report covers EMC technical requirements. It does not cover administrative issues such as Manual or non-EMC test related Requirements. (if applicable)
- The all test items in this test report are conducted by UL Japan, Inc. Ise EMC Lab.
- The opinions and the interpretations to the result of the description in this report are outside scopes where UL Japan, Inc. has been accredited.
- The information provided from the customer for this report is identified in SECTION 1.

REVISION HISTORY

Original Test Report No.: 14289102H-B

Revision	Test Report No.	Date	Page Revised Contents
- (Original)	14289102H-B	June 21, 2022	-

Reference: Abbreviations (Including words undescribed in this report)

A2LA	The American Association for Laboratory Accreditation	GPS	Global Positioning System
AAN	Asymmetric Artificial Network	Hori.	Horizontal
AC	Alternating Current	ICES	Interference-Causing Equipment Standard
AM	Amplitude Modulation	I/O	Input/Output
AMN	Artificial Mains Network	IEC	International Electrotechnical Commission
Amp, AMP	Amplifier	IEEE	Institute of Electrical and Electronics Engineers
ANSI	American National Standards Institute	IF	Intermediate Frequency
Ant, ANT	Antenna	ILAC	International Laboratory Accreditation Conference
AP	Access Point	ISED	Innovation, Science and Economic Development Canada
ASK	Amplitude Shift Keying	ISN	Impedance Stabilization Network
Atten., ATT	Attenuator	ISO	International Organization for Standardization
AV	Average	JAB	Japan Accreditation Board
BPSK	Binary Phase-Shift Keying	LAN	Local Area Network
BR	Bluetooth Basic Rate	LCL	Longitudinal Conversion Loss
BT	Bluetooth	LIMS	Laboratory Information Management System
BT LE	Bluetooth Low Energy	LISN	Line Impedance Stabilization Network
BW	BandWidth	MRA	Mutual Recognition Arrangement
C.F	Correction Factor	N/A	Not Applicable
Cal Int	Calibration Interval	NIST	National Institute of Standards and Technology
CAV	CISPR AV	NS	No signal detect.
CCK	Complementary Code Keying	NSA	Normalized Site Attenuation
CDN	Coupling Decoupling Network	OBW	Occupied BandWidth
Ch., CH	Channel	OFDM	Orthogonal Frequency Division Multiplexing
CISPR	Comite International Special des Perturbations Radioelectriques	PER	Packet Error Rate
Corr.	Correction	PK	Peak
CPE	Customer premise equipment	P _{LT}	long-term flicker severity
CW	Continuous Wave	POHC(A)	Partial Odd Harmonic Current
DBPSK	Differential BPSK	Pol., Pola.	Polarization
DC	Direct Current	PR-ASK	Phase Reversal ASK
DET	Detector	P _{ST}	short-term flicker severity
D-factor	Distance factor	QAM	Quadrature Amplitude Modulation
Dmax	maximum absolute voltage change during an observation period	QP	Quasi-Peak
DQPSK	Differential QPSK	QPSK	Quadrature Phase Shift Keying
DSSS	Direct Sequence Spread Spectrum	r.m.s., RMS	Root Mean Square
DUT	Device Under Test	RBW	Resolution BandWidth
EDR	Enhanced Data Rate	RE	Radio Equipment
e.i.r.p., EIRP	Equivalent Isotropically Radiated Power	REV	Reverse
EM clamp	Electromagnetic clamp	RF	Radio Frequency
EMC	ElectroMagnetic Compatibility	RFID	Radio Frequency Identifier
EMI	ElectroMagnetic Interference	RNSS	Radio Navigation Satellite Service
EMS	ElectroMagnetic Susceptibility	RSS	Radio Standards Specifications
EN	European Norm	Rx	Receiving
e.r.p., ERP	Effective Radiated Power	SINAD	Ratio of (Signal + Noise + Distortion) to (Noise + Distortion)
ETSI	European Telecommunications Standards Institute	S/N	Signal to Noise ratio
EU	European Union	SA, S/A	Spectrum Analyzer
EUT	Equipment Under Test	SG	Signal Generator
Fac.	Factor	SVSWR	Site-Voltage Standing Wave Ratio
FCC	Federal Communications Commission	THC(A)	Total Harmonic Current
FHSS	Frequency Hopping Spread Spectrum	THD(%)	Total Harmonic Distortion
FM	Frequency Modulation	TR, T/R	Test Receiver
Freq.	Frequency	Tx	Transmitting
FSK	Frequency Shift Keying	VBW	Video BandWidth
Fund	Fundamental	Vert.	Vertical
FWD	Forward	WLAN	Wireless LAN
GFSK	Gaussian Frequency-Shift Keying	xDSL	Generic term for all types of DSL technology
GNSS	Global Navigation Satellite System		(DSL: Digital Subscriber Line)

CONTENTS	PAGE
SECTION 1: Customer information	5
SECTION 2: Equipment under test (EUT).....	5
SECTION 3: Test specification, procedures & results	6
SECTION 4: Operation of EUT during testing.....	9
SECTION 5: Radiated Emission.....	10
APPENDIX 1: Test data	12
Radiated Emission	12
APPENDIX 2: Test instruments	14
APPENDIX 3: Photographs of test setup.....	15
Radiated Emission	15
Worst Case Position.....	17

SECTION 1: Customer information

Company Name	Mitsubishi Electric Corporation Himeji works
Address	840, Chiyoda-machi, Himeji, Hyogo 670-8677, Japan
Telephone Number	+81-79-298-9580
Contact Person	Yasuhiro Takahashi

The information provided from the customer is as follows;

- Customer, Description of EUT, Model Number of EUT, FCC ID on the cover and other relevant pages
- Operating/Test Mode(s) (Mode(s)) on all the relevant pages
- SECTION 1: Customer Information
- SECTION 2: Equipment Under Test (EUT) other than the Receipt Date and Test Date
- SECTION 4: Operation of EUT during testing

* The laboratory is exempted from liability of any test results affected from the above information in SECTION 2 and 4.

SECTION 2: Equipment under test (EUT)

2.1 Identification of EUT

Description	Smart Keyless System (Smart Unit)
Model Number	SKE8AD-03
Serial Number	Refer to SECTION 4.2
Condition	Production prototype (Not for Sale: This sample is equivalent to mass-produced items.)
Modification	No Modification by the test lab
Receipt Date	May 26, 2022
Test Date	June 5, 2022

2.2 Product Description

General Specification

Rating	DC 12.0 V
--------	-----------

Radio Specification

[LF part] *1)

Equipment Type	Transmitter
Frequency of Operation	125 kHz
Type of Modulation	ASK

*1) The test of this function was performed separately from this test report, and the conformability is confirmed.

[RF part]

Type of Receiver	Receiver
Receiving Frequency	315 MHz
Local Oscillator Frequency	314.72 MHz
Intermediate Frequency	280 kHz
Clock Frequency (maximum)	30.32 MHz
Voltage Controlled Oscillator	1888.32 MHz

SECTION 3: Test specification, procedures & results

3.1 Test Specification

Test Specification	FCC Part 15 Subpart B FCC Part 15 final revised on April 1, 2022 and effective May 2, 2022
Title	FCC 47CFR Part15 Radio Frequency Device Subpart B Unintentional Radiators

3.2 Procedures and results

Item	Test Procedure	Limits	Deviation	Worst margin	Result	Remarks
Conducted emission	FCC: ANSI C63.4: 2014 7. AC power - line conducted emission measurements	FCC: Part 15 Subpart B 15.107(a)	N/A	N/A	N/A	*1)
	ISED: RSS-Gen 7.1	ISED: RSS-Gen 7.2				
Radiated emission	FCC: ANSI C63.4: 2014 8. Radiated emission measurements	FCC: Part 15 Subpart B 15.109(a)	N/A	22.29 dB 1888.320 MHz, AV, Horizontal	Complied a)	-
	ISED: RSS-Gen 7.1	ISED: RSS-Gen 7.3				
Antenna Terminal	FCC: ANSI C63.4: 2014 12. Measurement of unintentional radiators other than ITE	FCC: Part 15 Subpart B 15.111(a)	N/A	N/A	N/A	*2)
	ISED: - RSS-Gen 7.1	ISED: RSS-Gen 7.4				
* Note: UL Japan, Inc.'s EMI Work Procedure: Work Instructions-ULID-003591.						
*1) The test is not applicable since the EUT is not the device that is designed to be connected to the public utility (AC) power line.						
*2) The receiving antenna (of this EUT) is installed inside the EUT and cannot be removed (permanently attached). Therefore, Radiated emission test was performed.						
a) Refer to APPENDIX 1 (data of Radiated Emission)						
Symbols:						
Complied The data of this test item has enough margin, more than the measurement uncertainty.						
Complied# The data of this test item meets the limits unless the measurement uncertainty is taken into consideration						

3.3 Addition to standard

No addition, exclusion nor deviation has been made from the standard.

3.4 Uncertainty

There is no applicable rule of uncertainty in this applied standard. Therefore, the results are derived depending on whether or not laboratory uncertainty is applied.

The following uncertainties have been calculated to provide a confidence level of 95 % using a coverage factor $k = 2$.

Radiated emission

Measurement distance	Frequency range		Uncertainty (+/-)
3 m	30 MHz to 200 MHz	Horizontal	4.8 dB
		Vertical	5.0 dB
	200 MHz to 1000 MHz	Horizontal	5.1 dB
		Vertical	6.2 dB
10 m	30 MHz to 200 MHz	Horizontal	4.8 dB
		Vertical	4.8 dB
	200 MHz to 1000 MHz	Horizontal	5.0 dB
		Vertical	5.0 dB
3 m	1 GHz to 6 GHz		5.1 dB
	6 GHz to 18 GHz		5.4 dB
1 m	10 GHz to 26.5 GHz		5.4 dB
	26.5 GHz to 40 GHz		5.4 dB
0.5 m	26.5 GHz to 40 GHz		5.4 dB
10 m	1 GHz to 18 GHz		5.4 dB

3.5 Test Location

UL Japan, Inc. Ise EMC Lab.

*A2LA Certificate Number: 5107.02 / FCC Test Firm Registration Number: 884919

ISED Lab Company Number: 2973C / CAB identifier: JP0002

4383-326 Asama-cho, Ise-shi, Mie-ken 516-0021 Japan

Telephone: +81-596-24-8999

Test site	Width x Depth x Height (m)	Size of reference ground plane (m) / horizontal conducting plane	Other rooms	Maximum measurement distance
No.1 semi-anechoic chamber	19.2 x 11.2 x 7.7	7.0 x 6.0	No.1 Power source room	10 m
No.2 semi-anechoic chamber	7.5 x 5.8 x 5.2	4.0 x 4.0	-	3 m
No.3 semi-anechoic chamber	12.0 x 8.5 x 5.9	6.8 x 5.75	No.3 Preparation room	3 m
No.3 shielded room	4.0 x 6.0 x 2.7	N/A	-	-
No.4 semi-anechoic chamber	12.0 x 8.5 x 5.9	6.8 x 5.75	No.4 Preparation room	3 m
No.4 shielded room	4.0 x 6.0 x 2.7	N/A	-	-
No.5 semi-anechoic chamber	6.0 x 6.0 x 3.9	6.0 x 6.0	-	-
No.5 measurement room	6.4 x 6.4 x 3.0	6.4 x 6.4	-	-
No.6 shielded room	4.0 x 4.5 x 2.7	4.0 x 4.5	-	-
No.6 measurement room	4.75 x 5.4 x 3.0	4.75 x 4.15	-	-
No.7 shielded room	4.7 x 7.5 x 2.7	4.7 x 7.5	-	-
No.8 measurement room	3.1 x 5.0 x 2.7	3.1 x 5.0	-	-
No.9 measurement room	8.8 x 4.6 x 2.8	2.4 x 2.4	-	-
No.10 shielded room	3.8 x 2.8 x 2.8	3.8 x 2.8	-	-
No.11 measurement room	4.0 x 3.4 x 2.5	N/A	-	-
No.12 measurement room	2.6 x 3.4 x 2.5	N/A	-	-

3.6 Test data, Test instruments, and Test set up

Refer to APPENDIX.

SECTION 4: Operation of EUT during testing

4.1 Operating Mode(s)

Mode	Remarks
1) Receiving mode	-
* EUT was set by the software as follows; Software: F9767001 Version: -	

*The test signal level was confirmed to be sufficient to stabilize the local oscillator of the EUT.

*Tuning was confirmed to be locked on each mode by checking local oscillator frequency to be stable using a search-coil.

4.2 Configuration and peripherals

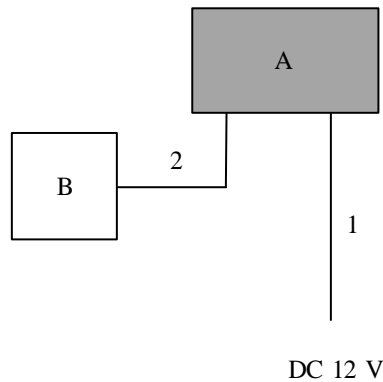

* Cabling and setup(s) were taken into consideration and test data was taken under worse case conditions.

Description of EUT and Support equipment

No.	Item	Model number	Serial number	Manufacturer	Remarks
A	Smart Keyless System (Smart Unit)	SKE8AD-03	20220519-E6 No.12	Mitsubishi Electric Corporation Himeji works	EUT
B	SW and Light	-	-	Mitsubishi Electric Corporation Himeji works	-

List of cables used

No.	Name	Length (m)	Shield		Remarks
			Cable	Connector	
1	DC Cable	1.50	Unshielded	Unshielded	-
2	Signal Cable	0.85	Unshielded	Unshielded	-

SECTION 5: Radiated Emission

5.1 Operating environment

Test place : No.4 semi anechoic chamber
Temperature : See data
Humidity : See data

5.2 Test configuration

EUT was placed on a urethane platform of nominal size, 1.0 m by 1.5 m, raised 0.8 m above the conducting ground plane.

The EUT was set on the edge of the tabletop.

Test was made with the antenna positioned in both the horizontal and vertical planes of polarization. The measurement antenna was varied in height above the conducting ground plane to obtain the maximum signal strength.

Photographs of the set up are shown in Appendix 3.

5.3 Test conditions

Frequency range : 30 MHz to 200 MHz (Biconical antenna) / 200 MHz to 1000 MHz (Logperiodic antenna)
1000 MHz to 10000 MHz (Horn antenna)
Test distance : 3 m
EUT position : Table top
EUT operation mode : See Clause 4.1

5.4 Test procedure

The height of the measuring antenna varied between 1 and 4 m and EUT was rotated a full revolution in order to obtain the maximum value of the electric field intensity.

The measurements were performed for both vertical and horizontal antenna polarization with the Test Receiver.

The radiated emission measurements were made with the following detector function of the Test Receiver.

For above 1 GHz, test antenna was aimed at the EUT for receiving the maximum signal and always kept within the illumination area of the 3 dB beamwidth of the antenna.

Frequency	Below 1GHz	Above 1GHz *1)
Instrument used	Test Receiver	Test Receiver
IF Bandwidth	QP: BW 120 kHz	PK: BW 1 MHz, CAV: BW 1 MHz

*1) The measurement data was adjusted to a 3 m distance using the following Distance Factor.
Distance Factor: See Figure 1.

Figure 1: Test Setup

Below 1 GHz

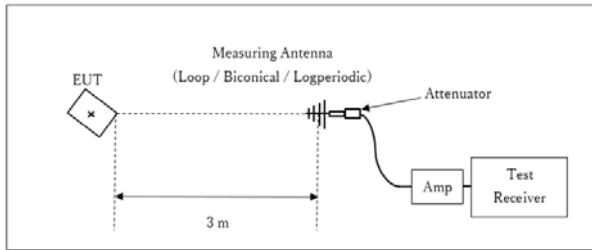

* : Center of turn table

Test Distance: 3 m

1 GHz to 10 GHz

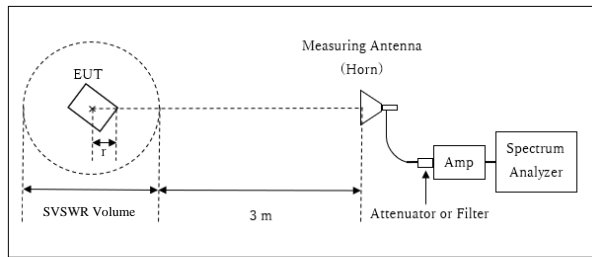

r : Radius of an outer periphery of EUT
* : Center of turn table

Distance Factor: $20 \times \log(3.95 \text{ m}^*/3.0 \text{ m}) = 2.39 \text{ dB}$
* Test Distance: $(3 + \text{SVSWR Volume} / 2) - r = 3.95 \text{ m}$

SVSWR Volume: 2 m
(SVSWR Volume has been calibrated based on CISPR 16-1-4.)
 $r = 0.05 \text{ m}$

- The noise levels were confirmed at each position of X, Y and Z axes of EUT to see the position of maximum noise, and the test was made at the position that has the maximum noise.

5.5 Test result

Summary of the test results: Pass

The limit is rounded down to one decimal place.

The test result is rounded off to one or two decimal places, so some differences might be observed.

APPENDIX 1: Test data

Radiated Emission

Test place Ise EMC Lab.
Semi Anechoic Chamber No.4
Date June 5, 2022
Temperature / Humidity 24 deg. C / 60 % RH
Engineer Ken Fujita
Mode Mode 1

Limit : FCC_Part 15 Subpart B(15.109)_Class B

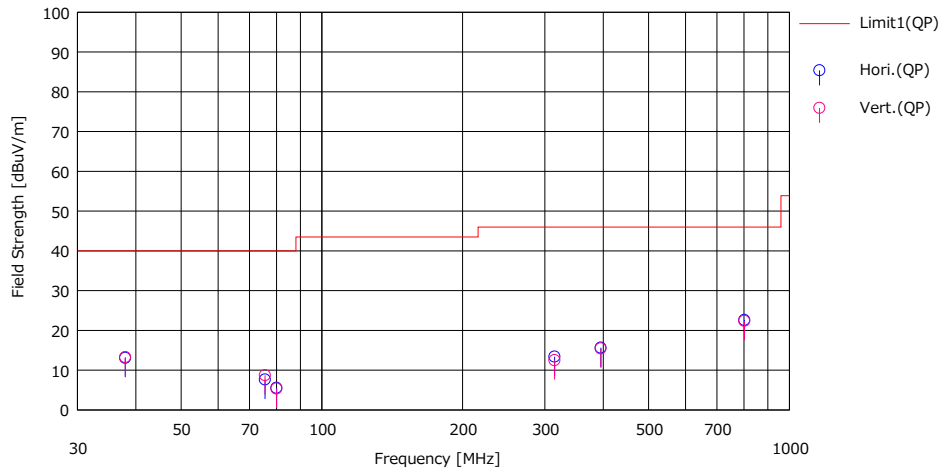

No.	Freq. [MHz]	Reading (QP) [dBuV]	Ant Fac [dB/m]	Loss [dB]	Gain [dB]	Result (QP) [dBuV/m]	Limit (QP) [dBuV/m]	Margin (QP) [dB]	Pola [H/V]	Height [cm]	Angle [deg]	Ant. Type	Comment
1	37.998	22.40	15.64	7.13	32.10	13.07	40.00	26.93	Hori.	100	56	BA	
2	75.620	25.60	6.50	7.61	32.09	7.62	40.00	32.38	Hori.	100	353	BA	
3	80.002	23.10	6.89	7.66	32.09	5.56	40.00	34.44	Hori.	100	189	BA	
4	314.720	21.80	14.13	9.51	32.05	13.39	46.00	32.61	Hori.	100	67	LA23	
5	395.212	21.90	15.83	10.03	32.13	15.63	46.00	30.37	Hori.	150	84	LA23	
6	801.817	21.60	20.90	11.91	31.82	22.59	46.00	23.41	Hori.	100	146	LA23	
7	37.998	22.60	15.64	7.13	32.10	13.27	40.00	26.73	Vert.	200	232	BA	
8	75.620	26.70	6.50	7.61	32.09	8.72	40.00	31.28	Vert.	100	208	BA	
9	80.002	22.90	6.89	7.66	32.09	5.36	40.00	34.64	Vert.	100	358	BA	
10	314.720	20.90	14.13	9.51	32.05	12.49	46.00	33.51	Vert.	100	151	LA23	
11	395.212	21.70	15.83	10.03	32.13	15.43	46.00	30.57	Vert.	100	231	LA23	
12	801.817	21.40	20.90	11.91	31.82	22.39	46.00	23.61	Vert.	100	93	LA23	

CHART: WITH FACTOR

ANT TYPE: - 30 MHz: LOOP, 30 MHz - 200 MHz: BICONICAL, 200 MHz - 1000 MHz: LOGPERIODIC, 1000 MHz -: HORN
CALCULATION: RESULT = READING + ANT FACTOR + LOSS(CABLE + ATT) - GAIN(AMP)

Except for the above table: adequate margin data below the limits.

Radiated Emission

Test place	Ise EMC Lab.
Semi Anechoic Chamber	No.4
Date	June 5, 2022
Temperature / Humidity	24 deg. C / 60 % RH
Engineer	Ken Fujita
Mode	Mode 1

Limit : FCC_Part 15 Subpart B(15.109)_Class B

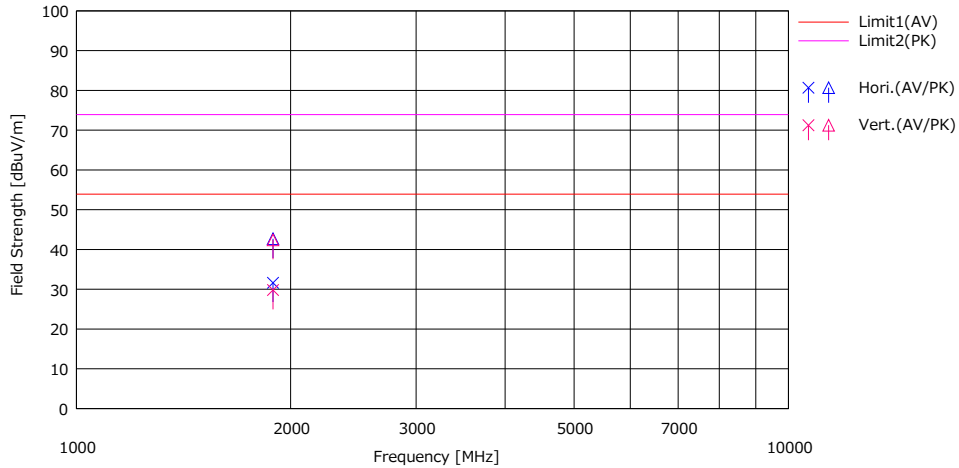

No.	Freq. [MHz]	Reading		Ant.Fac [dB/m]	Loss [dB]	Gain [dB]	Result		Limit		Margin		Pola [H/V]	Height [cm]	Angle [deg]	Ant. Type	Comment
		(AV) [dBuV]	(PK) [dBuV]				(AV) [dBuV/m]	(PK) [dBuV/m]	(AV) [dBuV/m]	(PK) [dBuV/m]	(AV) [dB]	(PK) [dB]					
1	1888.320	33.72	44.80	25.64	4.49	32.24	31.61	42.69	53.90	73.90	22.29	31.21	Hori.	100	0	HA30	
2	1888.320	31.90	44.50	25.64	4.49	32.24	29.79	42.39	53.90	73.90	24.11	31.51	Vert.	100	0	HA30	

CHART: WITH FACTOR

ANT TYPE: - 30 MHz: LOOP, 30 MHz - 200 MHz: BICONICAL, 200 MHz - 1000 MHz: LOGPERIODIC, 1000 MHz -: HORN

CALCULATION: RESULT = READING + ANT FACTOR + LOSS(CABLE + D-factor) - GAIN(AMP)

Except for the above table: adequate margin data below the limits.

APPENDIX 2: Test instruments

Test equipment

Test Item	Local ID	LIMS ID	Description	Manufacturer	Model	Serial	Last Calibration Date	Cal Int
RE	COTS-MEMI-02	178648	EMI measurement program	TSJ (Techno Science Japan)	TEPTO-DV	-	-	-
RE	MAEC-04	142011	AC4_Semi Anechoic Chamber(NSA)	TDK	Semi Anechoic Chamber 3m	DA-10005	05/22/2022	24
RE	MAEC-04-SVSWR	142017	AC4_Semi Anechoic Chamber(SVSWR)	TDK	Semi Anechoic Chamber 3m	DA-10005	04/12/2021	24
RE	MAT-34	141331	Attenuator(6dB)	TME	UFA-01	-	02/25/2022	12
RE	MBA-05	141425	Biconical Antenna	Schwarzbeck Mess-Elektronik OHG	VHA9103+BBA9106	VHA 91031302	08/28/2021	12
RE	MCC-257	208936	Microwave Cable	Huber+Suhner	SF126E/11PC35/11PC35/1000M,5000M	537061/126E / 537076/126E	07/18/2021	12
RE	MCC-50	141397	Coaxial Cable	UL Japan	-	-	11/03/2021	12
RE	MHA-30	141514	Horn Antenna 1-18GHz	Schwarzbeck Mess-Elektronik OHG	BBHA9120D	01611	06/01/2021	12
RE	MJM-29	142230	Measure	KOMELON	KMC-36	-	-	-
RE	MLA-23	141267	Logperiodic Antenna (200-1000MHz)	Schwarzbeck Mess-Elektronik OHG	VUSLP9111B	9111B-192	08/28/2021	12
RE	MMM-10	141545	DIGITAL HiTESTER	HIOKI E.E. CORPORATION	3805	51201148	01/16/2022	12
RE	MOS-15	141562	Thermo-Hygrometer	CUSTOM. Inc	CTH-201	0010	01/10/2022	12
RE	MPA-12	141581	MicroWave System Amplifier	Keysight Technologies Inc	83017A	00650	10/07/2021	12
RE	MPA-14	141583	Pre Amplifier	SONOMA INSTRUMENT	310	260833	04/04/2022	12
RE	MTR-09	141950	EMI Test Receiver	Rohde & Schwarz	ESU26	100412	2021/10/14	12

*Hyphens for Last Calibration Date and Cal Int (month) are instruments that Calibration is not required (e.g. software), or instruments checked in advance before use.

The expiration date of the calibration is the end of the expired month.

As for some calibrations performed after the tested dates, those test equipment have been controlled by means of an unbroken chains of calibrations.

All equipment is calibrated with valid calibrations. Each measurement data is traceable to the national or international standards.

Test item:

RE: Radiated emission