

836-JS08-20000 说明书 包装 _
V4500Plus_说明书_封面 157g 铜版纸四
色印刷_内纸 80g 书写纸单色印刷_胶装
_100*150mm_V1

20240409

V4500 *Plus*

Jump Starter & Battery Tester

USER MANUAL



TOPDON®

ENGLISH

1. SAFETY

For your safety and the safety of others, and to avoid any damage to the product and your vehicle, CAREFULLY READ AND MAKE SURE YOU FULLY UNDERSTAND ALL THE SAFETY INSTRUCTIONS AND MESSAGES ON THIS MANUAL BEFORE OPERATING.

- ALWAYS WEAR APPROVED SAFETY GOOGLES while working near a battery.
- ONLY use the battery clamps that come with this product.
- DO NOT use this product if the cable or the jump starter has any damage.
- DO NOT put the product under direct sunlight or in high temperature areas.
- DO NOT disassemble the product.
- DO NOT SMOKE OR HAVE ANY FLAMES NEAR THE VEHICLE when testing. The fuel and battery vapors are highly flammable.
- Battery acid is extremely corrosive. If acid gets into your eyes, FLUSH THEM THOROUGHLY WITH COLD RUNNING WATER FOR AT LEAST 20 MINUTES AND SEEK MEDICAL ATTENTION IMMEDIATELY. If battery acid gets on your skin or clothing, WASH IT IMMEDIATELY WITH A SOLUTION OF WATER AND BAKING SODA.

2. WHAT'S IN THE BOX?

- V4500 Plus (with Jump Start Clamps)
- Battery Test Clamps
- PD100W Cable
- PD45W Charger Adapter
- DC Adapter
- User Manual

3. ABOUT V4500 PLUS

V4500 Plus is a multi-functional jump starter with the peak current as high as 4500A. It has a built-in Bluetooth chip and supports the testing of various 12V lead-acid batteries via a dedicated APP. Its internal 32000mAh battery can help to charge phones, tablets, computers, tire inflators and other electronic devices for many times. It also comes with high-lumen LEDs that can work as a regular flashlight with SOS and strobe functions.

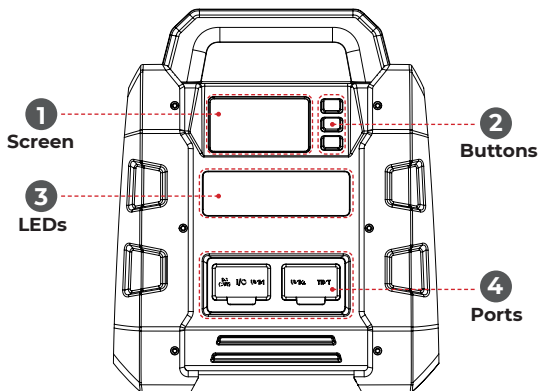

1. Screen

The icons on the screen are described below:

● About the input or output state

 When this icon is ON, it means V4500 Plus is being charged.

 When this icon is ON, it means V4500 Plus is discharging.

 When this icon is ON, it means V4500 Plus is being charged or discharging fast at the rate of 18W or above.

● About exceptions

 When this icon is ON, it means V4500 Plus is overheated. (V4500 Plus will return to normal temperature after it stops running.)

 When this icon is ON, it means short circuit or reverse polarity has occurred.

 When this icon is ON, it means an exception beyond the above two types has occurred.

● About battery charge

 The four levels from bottom to top represent 25%, 50%, 75% and 100% of charge respectively.

● About working modes

 Jump Start mode

 BOOST mode

 Battery Test mode

● About three steps of jump start



To connect the jump start clamps to the vehicle battery



To start the vehicle



To disconnect the jump start clamps from the vehicle battery

● About Bluetooth connection



When this icon is OFF, it means the Bluetooth function is disabled. (The Bluetooth function only works in the Battery Test mode.) When it is blinking, it means Bluetooth is disconnected. When it is solid ON, it means Bluetooth is connected.

● About voltage value



This icon will turn ON only in the Battery Test mode.

2. Buttons



Mode button



OK button



Power button

3. LEDs

LEDs can work in three ways: regular flashlight; SOS; strobe.

4. Ports

DC output port

USB-C input/output port

USB-A output port (x2)

Battery test port



4. INSTRUCTIONS FOR USE

4.1 Charging V4500 Plus

Note: We kindly recommend that you fully charge your V4500 Plus when you receive it so that you can use it at any time.

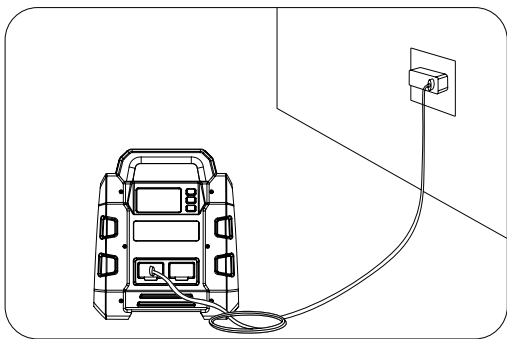
Use the PD100W cable and the PD45W charger adapter to charge V4500 Plus via the USB-C port.



During charging, the  icon on the screen of V4500 Plus will turn ON. If the charging rate reaches 18W or above, the  icon will also turn ON.





Note: The PD100W cable's maximum output power is 100W. You can choose to buy a charger adapter that supports PD100W so that you can enjoy super fast charging.

4.2 Jump Starting a Vehicle

Note: V4500 Plus can only be used to jump start vehicles powered by 12V lead-acid batteries.



V4500 Plus offers two modes: Jump Start and BOOST.

Jump Start Mode

1. Press the  button to power on V4500 Plus.
2. Press the  button to toggle between the ,  and  icons for selection.



The selected icon will turn ON and blink.

3. Select the  icon and press  to confirm your selection.

The  icon will become solid ON. The  icon will turn ON and blink. It means you need to connect the jump start clamps to the vehicle battery.

4. Connect the jump start clamps (on the left and right sides of V4500 Plus) to the vehicle battery.



The red clamp goes with the positive (+) terminal of the battery, and the black clamp goes with the negative (-) terminal of the battery.

When V4500 Plus detects that the connection of the jump start clamps to the vehicle battery is OK (with the voltage $\geq 3V$), the  icon will become solid ON and the  icon will turn ON and blink. It means you need to start the vehicle.

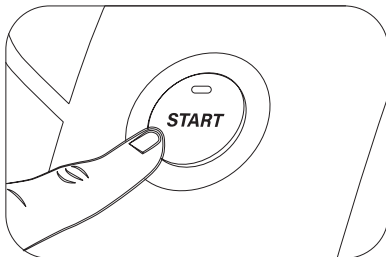

If the voltage is lower than 3V, the vehicle will not get started successfully in this mode. You can try the BOOST mode.

5. Start the vehicle.



When V4500 Plus detects that the vehicle is started, the  icon will become solid ON and the  will turn on and blink. It means you can disconnect the jump start clamps from the vehicle battery.

6. Disconnect the jump start clamps from the vehicle battery.

When V4500 Plus detects that the jump start clamps are disconnected from the vehicle battery, the ,  and  icons will all turn OFF.

7. Press and hold the  button for 7 seconds to power off V4500 Plus and place the jump start clamps back to its two sides. (Without any action in 15 seconds, V4500 Plus will automatically shut down.)



Note: If the vehicle fails to get started, please disconnect the jump start clamps from the vehicle battery. You can try again 20 seconds later. We strongly recommend that you do not jump start a vehicle for more than three times within two minutes.

BOOST Mode

If a vehicle fails to get started in the Jump Start mode, it may be because the voltage between the jump start clamps is lower than 3V. You can try the BOOST mode.

IMPORTANT: It is never allowed to directly connect the positive jump start clamp to the negative one in the BOOST mode. Otherwise, there will be a strong current that may cause damage, injury or even death.

The operation in the BOOST mode is similar to that in the Jump Start mode. The only difference is that you need to select the  icon as the working mode.

Note: V4500 Plus will output for 3 minutes in the BOOST mode. After that, you can press and hold the  button for 7 seconds to power off V4500 Plus. Or you can press the  button to change to another mode to stop the BOOST output.

4.3 Testing a Battery

Note: V4500 Plus can only be used to test 12V lead-acid batteries.

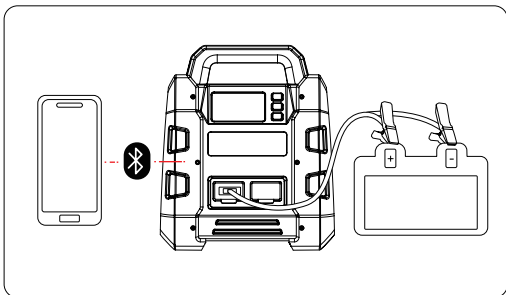

1. Go to Google Play or App Store to download the **BatteryLab** app, and install it on your phone.

You can also download the app from TOPDON's website:
<https://www.topdon.com/products/V4500-Plus>

2. Press the  button to power on V4500 Plus, and press the  button to select the  icon. Then press the  button to confirm your selection.

The  icon on the screen of V4500 Plus will turn ON and blink.

3. Enable the Bluetooth function of your phone, and then launch the app.

4. Follow the on-screen instructions of the app to add V4500 Plus via Bluetooth connection. (Bluetooth name of V4500 Plus: **Jump Surge X**)

When Bluetooth is connected, the  icon on the screen of V4500 Plus will become solid ON.

Note: You must launch the app and then establish Bluetooth connection with V4500 Plus from inside the app. With Bluetooth connected, V4500 Plus will not automatically shut down. If Bluetooth is not connected within 1 minute, V4500 Plus will automatically shut down.

5. Use the battery test clamps to connect V4500 Plus and the vehicle battery.

Plug one end into the battery test port  of V4500 Plus, and connect the red and black clamps on the other end to the positive and negative terminals of the battery respectively.

6. Follow the on-screen instructions of the app to test the battery.

7. After the testing, press and hold the  button for 7 seconds to power off V4500 Plus and then remove the battery test clamps.

4.4 Using V4500 Plus as a Power Bank



The internal battery of V4500 Plus has a capacity of 32000 mAh, which makes it a reliable power bank that can charge your phones, tablets, computers, tire inflators or other electronic devices for many times. V4500 Plus comes with multiple output ports: one DC port, one USB-C port and two USB-A ports. You can choose to use any of them according to your needs.

Connect V4500 Plus to an electronic device, and then press the  button to power on V4500 Plus. The discharging will begin immediately.

During the discharging, the  icon on the screen V4500 Plus will turn ON. If the discharging rate reaches 18W or above, the  icon will also turn ON.

4.5 Using LEDs

V4500 Plus comes with high-lumen LEDs that can work in three ways: regular flashlight; SOS; strobe.

After powering on V4500 Plus, press the  button for 3 seconds to turn on the LEDs. You can press the  button again to switch to a different state in this order: regular flashlight > SOS > strobe > OFF.

5. TECHNICAL SPECS

Model	V4500 Plus
Peak Current	4500A
Battery Capacity	3.7V, 32000mAh; 120Wh
USB-C Input/Output	PD100W, 5V 3A, 9V 3A, 12V 3A, 15V 3A, 20V 3A, 20V 5A
USB-A Output	QC18W, 5V 3A, 9V 2A, 12V 1.5A
DC Output	Max 16.8V 10A

6. FAQ

Q: What can I do when my vehicle failed to get started?

A: Please ensure the charge level of V4500 Plus is above 50%, and shift to the BOOST mode to start your vehicle.

Q: How long does it take to fully charge the product?

A: A: The charging time depends on the power of the charger that you use. Using a PD45W charger to get the device fully charged will cost about 2.5 hours.

Q: Is there any advice on battery testing?

A: To test a battery, you should get it fully charged first. Then leave it alone for at least 6 hours before testing.

Q: Can this product be used to test LiFePO4 batteries?

A: No, currently the product does not support testing of LiFePO4 batteries.

Q: Why does Bluetooth connection fail?

A: Before Bluetooth connection, some necessary permissions (such as location) must be granted. Bluetooth connection must be established from inside the app. If you have already established Bluetooth connection with the device via your phone's system settings, please undo it first and then try to establish Bluetooth connection from inside the app.

7. WARRANTY

TOPDON's One-Year Limited Warranty

TOPDON warrants to its original purchaser that the company's products will be free from defects in material and workmanship for 12 months from the date of purchase (Warranty Period).

For the defects reported during the Warranty Period, TOPDON will either repair or replace the defective part or product according to its technical support analysis and confirmation.

TOPDON shall not be liable for any incidental or consequential damages arising from the device's use, misuse, or mounting.

If there is any conflict between the TOPDON warranty policy and local laws, the local laws shall prevail.

This limited warranty is void under the following conditions:

- Misused, disassembled, altered or repaired by unauthorized stores or technicians.
- Careless handling and operation's violation.

Notice: All information in this manual is based on the latest information available at the time of publication and no warranty can be made for its accuracy or completeness. TOPDON reserves the right to make changes at any time without notice.

8. FCC STATEMENT

Any changes or modifications not expressly approved by the party responsible for compliance could void the user's authority to operate the equipment.

This device complies with Part 15 of the FCC Rules.

Operation is subject to the following two conditions:

- (1) this device may not cause harmful interference, and
- (2) this device must accept any interference received, including interference that may cause undesired operation.

Note: This equipment has been tested and found to comply with the limits for a Class B digital device, pursuant to Part 15 of the FCC Rules.

These limits are designed to provide reasonable protection against harmful interference in a residential installation. This equipment generates, uses, and can radiate radio frequency energy, and if not installed and used in accordance with the instructions, may cause

harmful interference to radio communications. However, there is no guarantee that interference will not occur in a particular installation. If this equipment does cause harmful interference to radio or television reception, which can be determined by turning the equipment off and on, the user is encouraged to try to correct the interference by one or more of the following measures:

- Reorient or relocate the receiving antenna.
- Increase the separation between the equipment and receiver.
- Connect the equipment into an outlet on a circuit different from that to which the receiver is connected.
- Consult the dealer or an experienced radio/TV technician for help.

	TEL	86-755-21612590 1-833-629-4832 (NORTH AMERICA)
	EMAIL	SUPPORT@TOPDON.COM
	WEBSITE	WWW.TOPDON.COM
	FACEBOOK	@TOPDONOFFICIAL
	X	@TOPDONOFFICIAL



合同会社BLUEデジタル